



Chunghwa Picture Tubes, Ltd. Technical Specification

To : Studio Technology Co.,Ltd

Date : 2004.01.16

CPT TFT-LCD

CLAA130VA01

ACCEPTED BY :

APPROVED BY	CHECKED BY	PREPARED BY
	Steve Sun	TFT-LCD Product Planning Management Division

Prepared by : TFT-LCD Product Planning Management Division

CHUNGHWA PICTUER TUBES, LTD.

1127 Hopin Rd., Padeh, Taoyuan, Taiwan 334, R.O.C.
TEL: +886-3-3675151 FAX: +886-3-377-3001

Doc.No:	CLAA130VA01-NOVA-Ver.1-2004/01/16	Issue Date:	2004-01-16
---------	-----------------------------------	-------------	------------

T- 3650002- 000- A
NEW

1. OVERVIEW

CLAA130VA01 is 13.0" color TFT-LCD (Thin Film Transistor Liquid Crystal Display) module composed of LCD panel, driver ICs, control circuit and backlight.

By applying 8 bit digital data, 640×480, 16.7M-color images are displayed on the 13.0" diagonal screen. Input power voltage is 5.0V for LCD driving.

Inverter for backlight is not included in this module. General specification are summarized in the following table:

ITEM		SPECIFICATION
Display Area(mm)		264.0(H)×198.0(V) (13.0-inch diagonal)
Number of Pixels		640×3(H)×480(V)
Pixel Pitch(mm)		0.4125(H)×0.4125(V)
Color Pixel Arrangement		RGB vertical stripe
Display Mode		normally white TN
Number of Colors		16.7M(8bits/color)
Brightness(cd/m ²)		450(cd/m ²)(Typ.)
Viewing Angle	CR 5	-85~85(H) , -85~70(V)
	CR 10	-65~65(H) , -60~50(V)
Wide Viewing Angle Technology		Optical Compensation Film
Surface Treatment		Anti-glare,3H
Electrical Interface		CMOS(VIN=3~5V,1 pixel/clock)
Total Module Power(W)		14.3(Typ.)
Optimum Viewing Angle		6 o'clock
Module Size(mm)		286.0(W) × 225.0(H) × 15.8(D)
Module Weight(g)		1050(Typ.) , 1100(Max.)
Backlight Unit		4 CCFLs edge-light(top/bottom)

The LCD Products listed on this document are not suitable for use of aerospace equipment, submarine cables, nuclear reactor control system and life support systems. If customers intend to use these LCD products for above application or not listed in "Standard" as follows, please contact our sales people in advance. Standard: Television, Car TV, Office equipment, Communication equipment, Test and Measurement equipment, Machine tool, Industrial robot, Audio and Visual equipment, Other consumer products.

2. ABSOLUTE MAXIMUM RATINGS

ITEM	SYMBOL	MIN.	MAX.	UNIT
Power Supply Voltage for LCD	VCC	0	7.0	V
Input Voltage	VIN	-0.3	6.0	V
Lamp Voltage	VL	0	2000	Vrms
Lamp Current	IL	0	9.0	mArms
Lamp frequency	FL	--	100	kHz
Static Electricity	VESDt	-100	100	V
	VESDc	-8000	8000	V
ICC Rush Current	IRUSH	-	12	A
Operation Temperature	T _{op}	0	50	
Storage Temperature	T _{stg}	-20	60	

Note:

- *1) Test Condition: IEC 1000-4-2 ,
VESDt : Contact discharge to input connector
VESDc : Contact discharge to module
- *2) 50 μ sec , If Vcc rise time increase then I_{RUSH} decrease.
- *3) Humidity 85% RH. without condensation.

3. ELECTRICAL CHARACTERISTICS

(a)TFT-LCD

ITEM	SYMBOL	MIN	TYP	MAX	UNIT	Remark
Power Supply Voltage for LCD	VCC	4.5	5.0	5.5	V	Note1
Power Supply Current for LCD	ICC	--	240	400	mA	Note2
Permissive Input Ripple Voltage	VRP	--	--	100	MVp-p	Vcc=5.0V
Input Threshold Voltage	High	VIH	2.2	3.3	V	
	Low	VIL	0	--	0.9	V

[Note 1]

Power and signal sequence :

t1 10ms 400ms t4
 200ms < t2 200ms t5
 0 < t3 50ms 0 t6

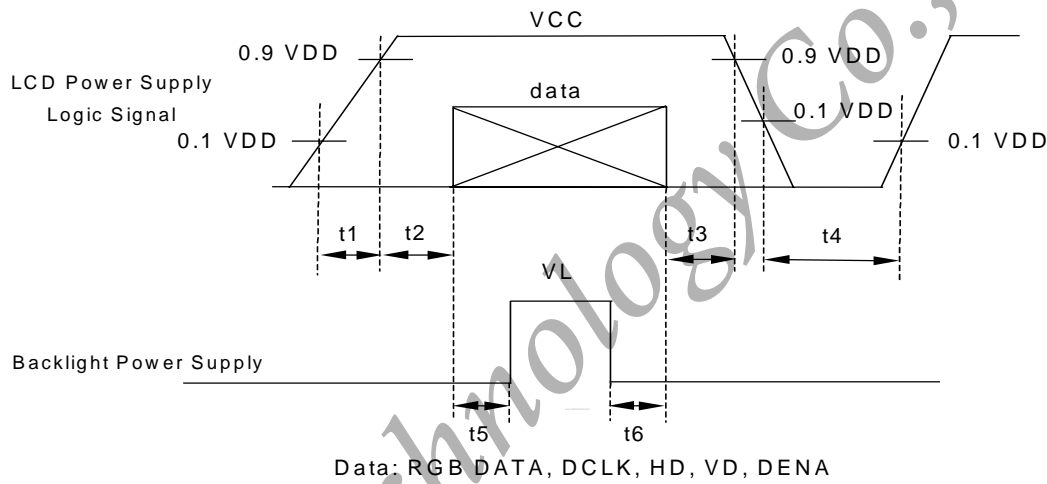

VCC-dip conditions

- 1)When 3.6V $VCC < 4.5V$, $t_d = 10\text{ ms}$
- 2)When $VCC > 4.5V$, VCC-dip conditions should also follow the VCC-turn-on conditions.
- 3)When $VCC < 3.6$, it works abnormal that must reset power.

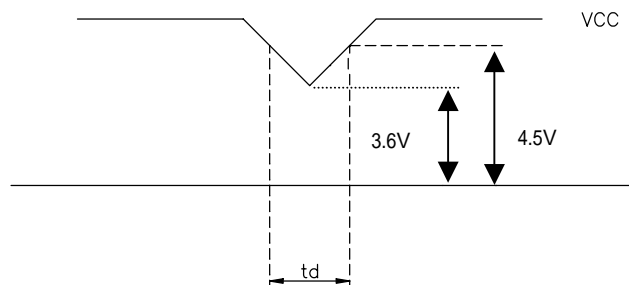

[Note 2] Typical current situation : 256-gray-bar pattern, 480 line mode,
 $VCC=5.0\text{ V}$, $f_H=31.5\text{ kHz}$, $f_V=60\text{ Hz}$, $f_{CLK}=25\text{ MHz}$

(b)Backlight

ITEM	SYMBOL	MIN	TYP	MAX	UNIT	REMARK
Lamp Voltage	VL	-	545	-	V	IL=6.0mA
Lamp Current	IL	3.5	6.0	7.0	mA	Note1
Interter Frequency	FL	40	-	70	kHz	Note2
Starting Lamp Voltage	VS	-	-	1500	V	Ta=0
		-	-	1300	V	Ta=25
Lamp life Time	LT	60000	-	-	hr	Note3 IL=6.0Ma Continuous Operation

[Note 1]

Lamp Current measurement method (The current meter is inserted in cold line)

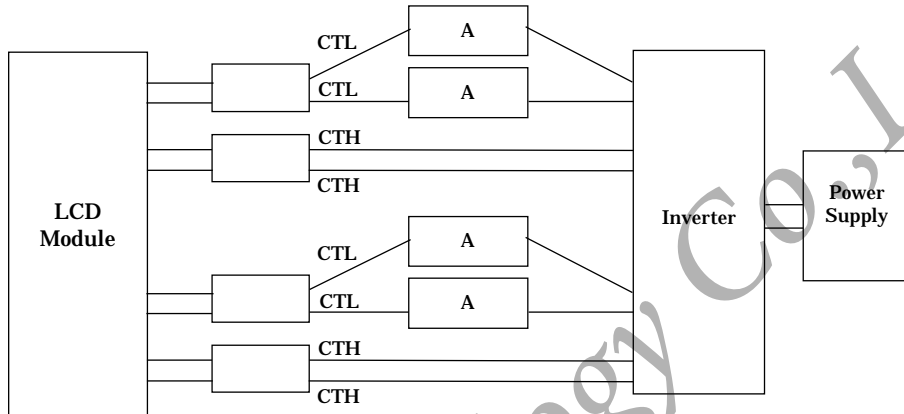

[Note 2]

Lamp frequency of inverter may produce interference with horizontal synchronous frequency, and this may cause horizontal beat on the display. Therefore, please adjust lamp frequency, and keep inverter as far from module as possible or use electronic shielding between inverter and module to avoid the interference.

The degrees of unbalance: less than 10%

The ratio of wave height: less than $2 \pm 10\%$

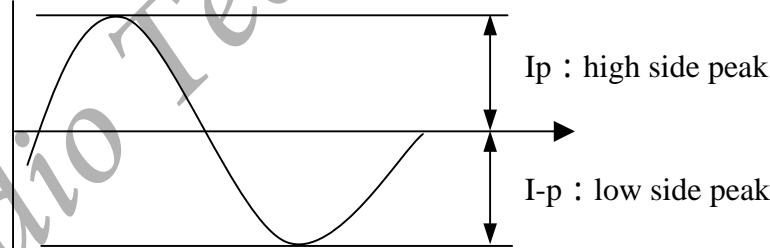

* : The degrees of unbalance = $| I_p - I-p | / I_{rms} \times 100 (\%)$

* : The ratio of wave height = $I_p \text{ (or } I-p) / I_{rms}$

[Note 3]

Definition of the lamp life time

Luminance: L under 50% of specification

Starting Lamp Voltage: VS < 1500V, Ta=0

VS < 1300V, Ta=25

The lamp shall be stably lighted. Slide up method shall be used for input voltage application. The voltage is applied voltage to both ends of the lamp as the established starting voltage.

4. INTERFACE PIN CONNECTION

(a) CN1(Data Signal and Power Supply)

Used connector: IL-FHR-BF40S-HF(JAE)

Pin	Symbol	Function
1	GND	
2	VCC	
3	VCC	
4	RO0	Red odd data (LSB)
5	RO1	Red odd data
6	RO2	Red odd data
7	RO3	Red odd data
8	GND	
9	RO4	Red odd data
10	RO5	Red odd data
11	RO6	Red odd data
12	RO7	Red odd data (MSB)
13	GND	
14	GO0	Green odd data (LSB)
15	GO1	Green odd data
16	GO2	Green odd data
17	GO3	Green odd data
18	GND	
19	GO4	Green odd data
20	GO5	Green odd data
21	GO6	Green odd data
22	GO7	Green odd data (MSB)
23	GND	
24	BO0	Blue odd data (LSB)
25	BO1	Blue odd data
26	BO2	Blue odd data
27	BO3	Blue odd data
28	GND	
29	BO4	Blue odd data
30	BO5	Blue odd data
31	BO6	Blue odd data
32	BO7	Blue odd data (MSB)
33	GND	
34	TEST	This pin should be open
35	HD	Horizontal Sync
36	VD	Vertical Sync
37	DENA	Data enable
38	GND	
39	DCLK	Dot Clock
40	GND	

(c) CN2,3(BACKLIGHT)

Backlight-side connector: BHSR-02VS-1(JST)

Inverter-side connector: SM02B-BHSS-1(JST)

Pin No.	Symbol	Function
1,2	CTH	VBLH(High voltage)

[Note] BLH-VBLL = VL

(d) CN4,5(BACKLIGHT)

Backlight-side connector: BHR-02VS-1(JST)

Inverter-side connector: SM02(4.0)-BHSS-1-TB(JST)

Pin No.	Symbol	Function
1,2	CTL	VBLL(Low voltage)

[Note] VBLH-VBLL = VL

5. INTERFACE TIMING

(a) Timing Specifications

ITEM		SYMBOL	MIN	TYP	MAX	UNIT
Clock DCLK *1) *4)	Frequency	f_{CLK}	20	25	30	MHz
	Period	t_{CLK}	33.3	40	50	ns
	Pulse Width(low)	t_{WCL}	5	--	--	ns
	Pulse Width(high)	t_{WCH}	5	--	--	ns
DATA*1) (R.G.B,DENA,HD,VD)	Set up Time	t_{Ds}	3	--	--	ns
	Hold Time	t_{Dh}	6	--	--	ns
DATA Enable DENA *3)	Horizontal Active Time	T_{HA}	640	640	640	t_{CLK}
	Horizontal Front Porch	t_{HFP}	32	48	--	t_{CLK}
	Horizontal Back Porch	t_{HBP}	56	66	--	t_{CLK}
	Vertical Active Time	T_{VA}	480	480	480	t_H
	Vertical Front Porch	t_{VFP}	2	3	--	t_H
	Vertical Back Porch	t_{VBP}	4	35	--	t_H
HD *2) *4)	Frequency	f_H	27	31.5	38	KHz
	Period	t_H	26.3	31.7	37.0	μs
	Pulse Width(low)	t_{WHL}	4	8	--	t_{CLK}
VD *2)	Frequency	f_V	55	60	70	Hz
	Period	t_V	14.2	16.7	18.2	ms
	Pulse Width(low)	t_{WVL}	2	6	--	t_H

[Note]

- 1) Data is latched at fall edge of DCLK in this specification.
- 2) Polarities of HD and VD are negative in this specification.
- 3) DENA(Data Enable) should always be positive polarity as shown in the timing specification.
- 4) DCLK should appear during all blanking period, and HD should appear during blanking period of frame cycle.
- 5) **FRC function is prohibited.**

(b) Timing Chart

a. Pixel Timing Chart

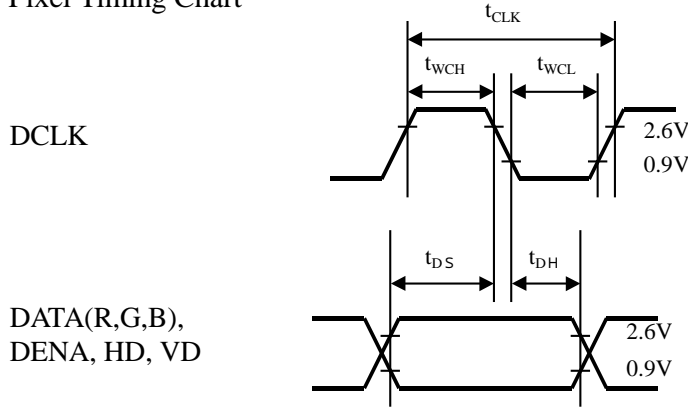

b. Horizontal Timing Chart

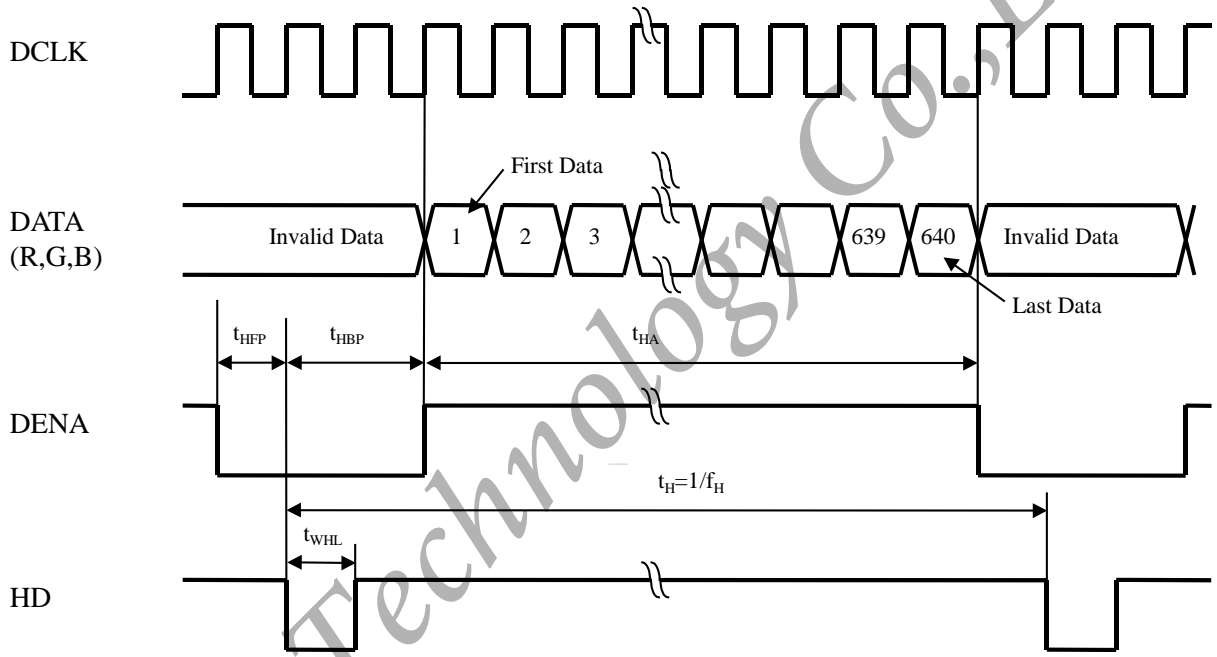

c. Vertical Timing Chart

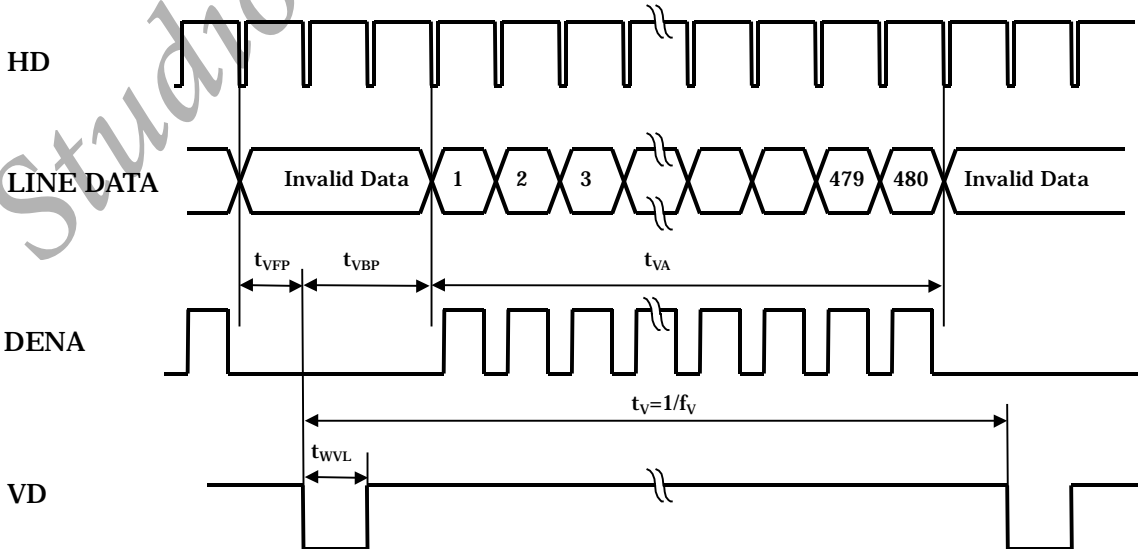

(c)Color Data Assignment

COLOR	INPUT DATA	R DATA								G DATA								B DATA							
		R7 MSB	R6	R5	R4	R3	R2	R1	R0 LSB	G7 MSB	G6	G5	G4	G3	G2	G1	G0 LSB	B7 MSB	B6	B5	B4	B3	B2	B1	B0 LSB
BASIC COLOR	BLACK	0	0	0	0	0	0	0	0	0	0	0	0	0	0	0	0	0	0	0	0	0	0	0	0
	RED(255)	1	1	1	1	1	1	1	1	0	0	0	0	0	0	0	0	0	0	0	0	0	0	0	
	GREEN(255)	0	0	0	0	0	0	0	0	1	1	1	1	1	1	1	0	0	0	0	0	0	0	0	
	BLUE(255)	0	0	0	0	0	0	0	0	0	0	0	0	0	0	0	1	1	1	1	1	1	1	1	
	CYAN	0	0	0	0	0	0	0	0	1	1	1	1	1	1	1	1	1	1	1	1	1	1	1	
	MAGENTA	1	1	1	1	1	1	1	1	0	0	0	0	0	0	0	0	0	1	1	1	1	1	1	
	YELLOW	1	1	1	1	1	1	1	1	1	1	1	1	1	1	1	0	0	0	0	0	0	0	0	
	WHITE	1	1	1	1	1	1	1	1	1	1	1	1	1	1	1	1	1	1	1	1	1	1	1	
RED	RED(0)	0	0	0	0	0	0	0	0	0	0	0	0	0	0	0	0	0	0	0	0	0	0		
	RED(1)	0	0	0	0	0	0	0	1	0	0	0	0	0	0	0	0	0	0	0	0	0	0		
	RED(2)	0	0	0	0	0	0	1	0	0	0	0	0	0	0	0	0	0	0	0	0	0	0		
	RED(254)	1	1	1	1	1	1	1	0	0	0	0	0	0	0	0	0	0	0	0	0	0	0		
	RED(255)	1	1	1	1	1	1	1	1	0	0	0	0	0	0	0	0	0	0	0	0	0	0		
GREEN	GREEN(0)	0	0	0	0	0	0	0	0	0	0	0	0	0	0	0	0	0	0	0	0	0	0		
	GREEN(1)	0	0	0	0	0	0	0	0	0	0	0	0	0	0	1	0	0	0	0	0	0	0		
	GREEN(2)	0	0	0	0	0	0	0	0	0	0	0	0	0	1	0	0	0	0	0	0	0	0		
	GREEN(254)	0	0	0	0	0	0	0	1	1	1	1	1	1	1	0	0	0	0	0	0	0	0		
	GREEN(255)	0	0	0	0	0	0	0	1	1	1	1	1	1	1	1	0	0	0	0	0	0	0		
BLUE	BLUE(0)	0	0	0	0	0	0	0	0	0	0	0	0	0	0	0	0	0	0	0	0	0	0		
	BLUE(1)	0	0	0	0	0	0	0	0	0	0	0	0	0	0	0	0	0	0	0	0	0	1		
	BLUE(2)	0	0	0	0	0	0	0	0	0	0	0	0	0	0	0	0	0	0	0	0	1	0		
	BLUE(254)	0	0	0	0	0	0	0	0	0	0	0	0	0	0	0	0	1	1	1	1	1	0		
	BLUE(255)	0	0	0	0	0	0	0	0	0	0	0	0	0	0	0	0	1	1	1	1	1	1		

[Note]

- (1)Definition of gray scale:
Color(n) : n indicates gray scale level.
Higher n means brighter level.
- (2)Data: 1-High,0-Low.

(d)Color Data Assignment

D(1, 1)	D(2, 1)	---	D(X, 1)	---	D(639, 1)	D(640, 1)
D(1, 2)	D(2, 2)	---	D(X, 2)	---	D(639, 2)	D(640, 2)
⋮	⋮	+	⋮	+	⋮	⋮
D(1, Y)	D(2, Y)	---	D(X, Y)	---	D(639, Y)	D(640, Y)
⋮	⋮	+	⋮	+	⋮	⋮
D(1,479)	D(2,479)	---	D(X,479)	---	D(639,479)	D(640,479)
D(1,480)	D(2,480)	---	D(X,480)	---	D(639,480)	D(640,480)

6. BLOCK DIAGRAM

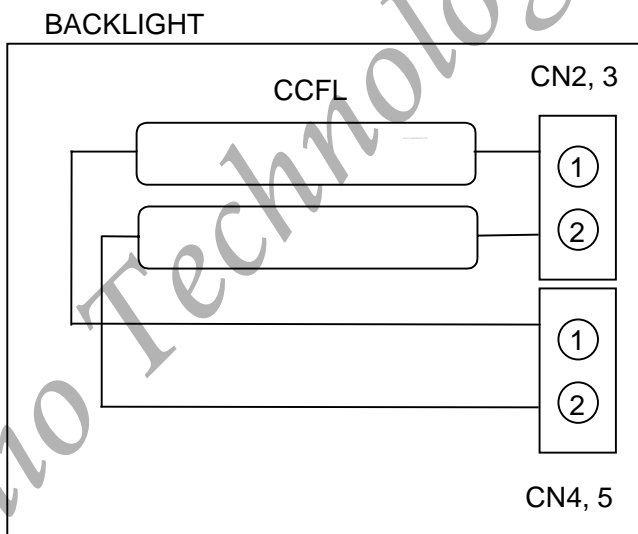
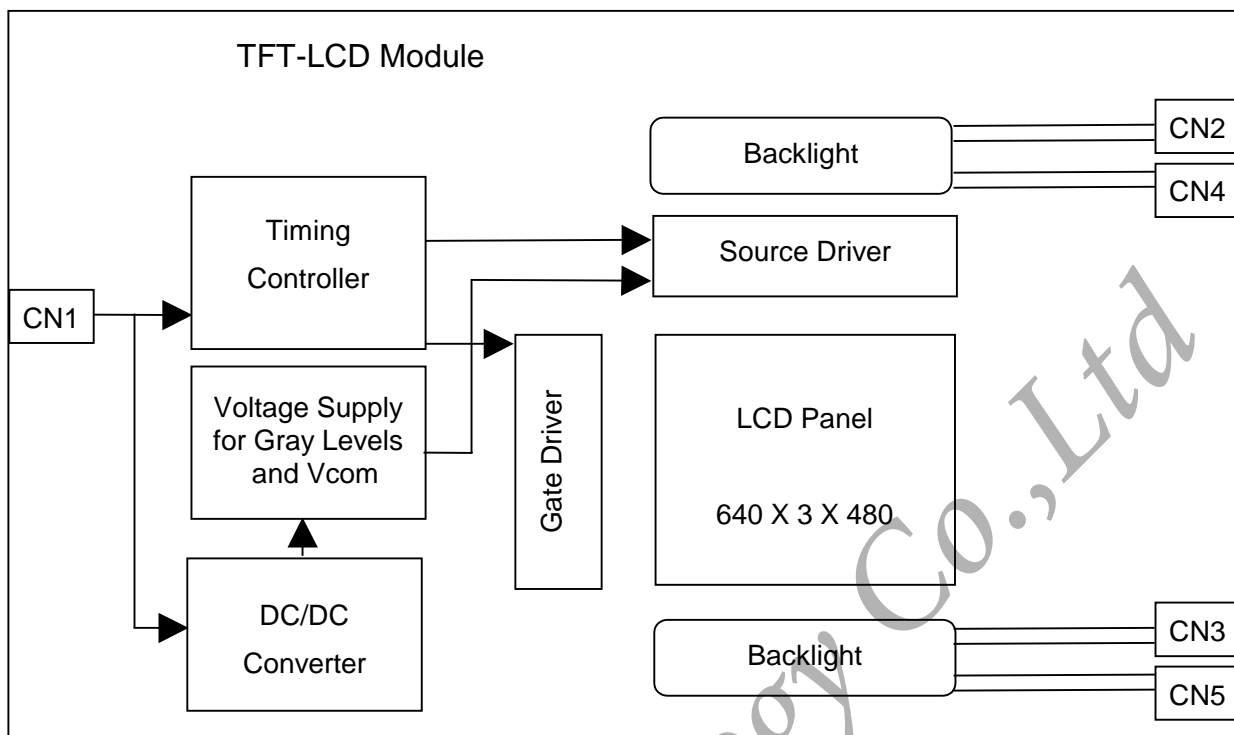

7. MECHANICAL SPECIFICATION

(a) Front side

Unit: mm

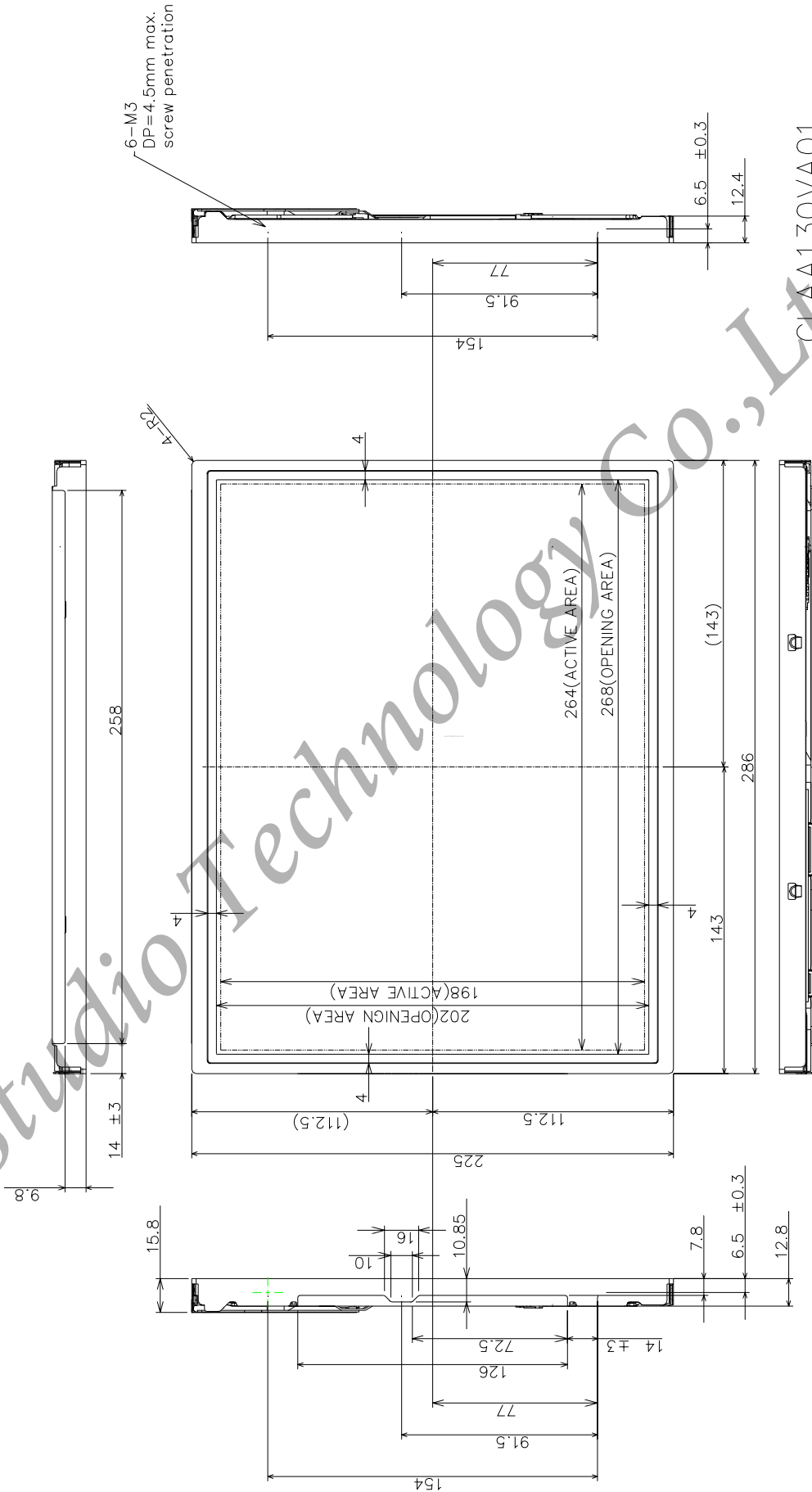

CLAA130VA01

- 1) Tolerance is ±0.5mm unless noted.
- 2) Except for thickness of PET film.

(b) Rear side

Unit: mm

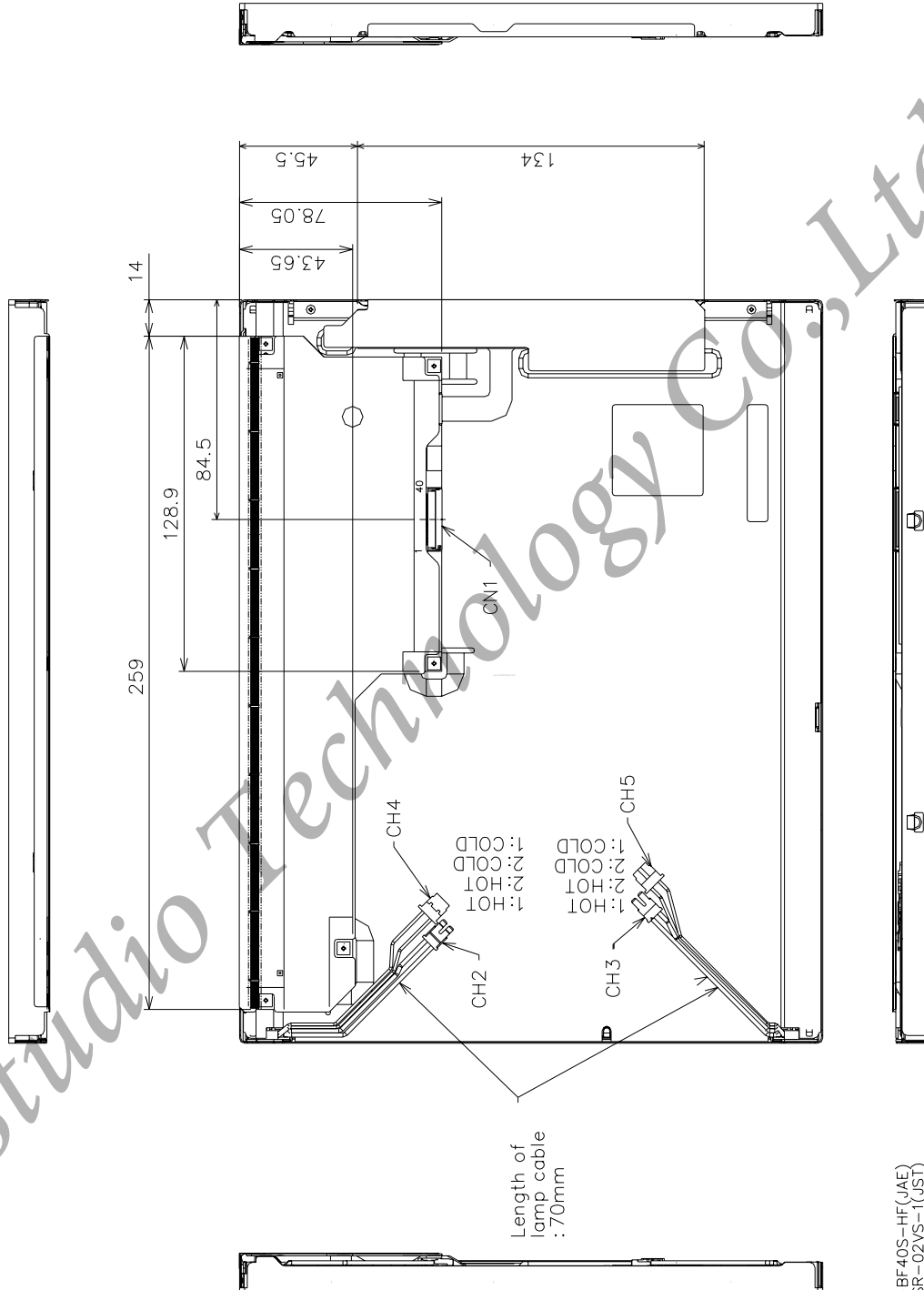

- 1) Tolerance is ±0.5mm unless noted.
- 2) Except for thickness of PET film.

- CN1: IL
- CN2,C
- CN4,C
- CN1:IL-FHR-BF40S-HF(JAE)
- CN2,CN3:BHSR-02VS-I(JST)
- CN4,CN5:BHR-02VS-I(JST)

8.OPTICAL CHARACTERISTICS

Ta=25 VCC=5.0V

ITEM		SYMBOL	CONDITION	MIN.	TYP.	MAX.	UNIT
Contrast Ratio		CR	$\theta = \phi = 0^\circ$ Point-5	350	500	--	--
Luminance	5 Point	Lw	$\theta = \phi = 0^\circ$	360	450	--	cd/m ²
	Uniformity	ΔLw	$\theta = \phi = 0^\circ$	--	--	25	%
Contrast Ratio uniformity		ΔCR	$\theta = \phi = 0^\circ$	--	--	30	%
Response Time (White - Black)		tr	$\theta = \phi = 0^\circ$	--	6	--	ms
		tf	$\theta = \phi = 0^\circ$	--	16	--	ms
Response Time (Gray Scale Level)		trg,tfg	$\theta = \phi = 0^\circ$	--	10	15	ms
Viewing Angle	Horizontal	ϕ	CR \geq 10 Point-5	-65~65	-65~65	--	°
	Vertical	θ		-50~40	-60~50	--	°
	Horizontal	ϕ	CR \geq 5 Point-5	-75~75	-85~85	--	°
	Vertical	θ		-75~55	-85~60	--	°
Cross talk Ratio		CTR(W)	$\theta = \phi = 0^\circ$	--	--	0.7	%
		CTR(B)		--	--	0.7	%
		CTR(W-B)		--	--	1.2	%
Color Coordinates	Red	Rx	$\theta = \phi = 0^\circ$ Point-5	0.610	0.635	0.660	--
		Ry		0.301	0.326	0.351	
	Green	Gx		0.242	0.267	0.292	
		Gy		0.571	0.596	0.621	
Blue	Bx	0.118		0.143	0.168		
	By	0.026		0.051	0.076		
White	Wx	0.260		0.285	0.310		
	Wy	0.272		0.297	0.322		
Chrome Deviation	Red	R _{1x}	$\theta = \phi = 0^\circ$	Value at Point-5 -0.02	Value at Point-5	Value at Point-5 +0.02	--
		R _{1y}					
	Green	G _{1x}					
		G _{1y}					
Blue	B _{1x}						
	B _{1y}						
White	W _{1x}						
	W _{1y}						
Color Temperature		Tc		--	9300	--	K
Color Gamut		CG		--	72	--	%

[Note]

These items are measured using BM-5A(TOPCON) OR LCD-7000 (Otsuka Electronic) under the dark room condition(no ambient light) after more than 30 minutes from turning on the lamp unless noted. Condition: IL=6.0mA, FL=60kHz

Definition of these measurement items are as follows:

*1)Definition of Contrast Ratio

CR=ON(White)Luminance/OFF(Black)Luminance

*2) Definition of Luminance and Luminance uniformity, Contrast Ratio, Contrast Ratio uniformity, Chrome Deviation.

Luminance & Contrast Ratio : Measurement point 5 (No.5) .

Luminance uniformity :The value of Lw (MAX) and Lw(MIN) is measurement point 1 to 5.

Formula: $Lw=[Lw(MAX)/Lw(MIN)-1]\times 100$

Contrast Ratio uniformity : The value of CR(MAX) and CR(MIN) is measurement point 1 to 9.

Formula: $CR=[CR(MAX)/CR(MIN)-1]\times 100$

Chrome Deviation : measurement point 1 to 9.

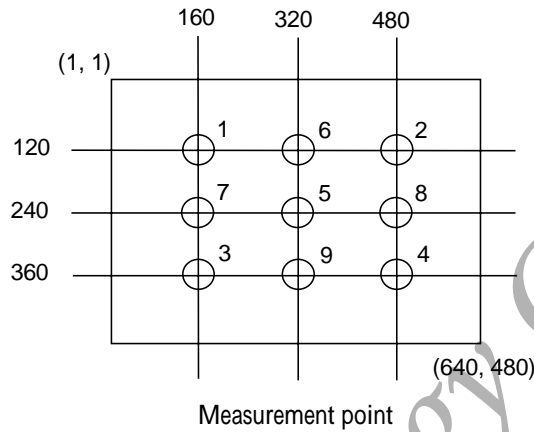

*3) Definition of Viewing Angle(,)

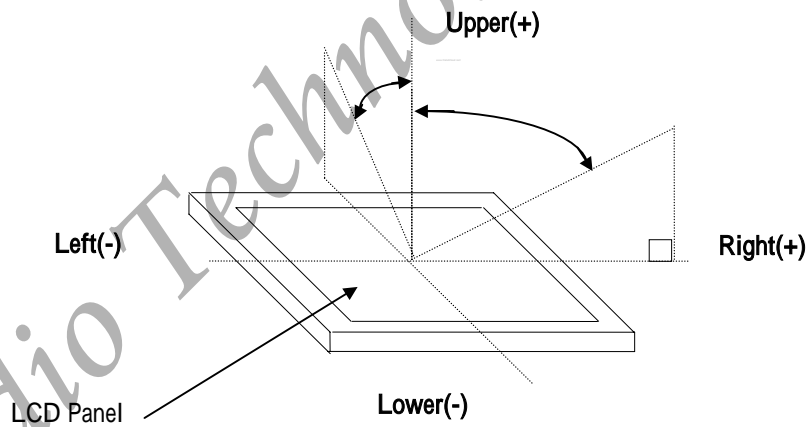

*4)Definition of Response Time(White - Black) (Test equipment:WESTAR TRD-100)

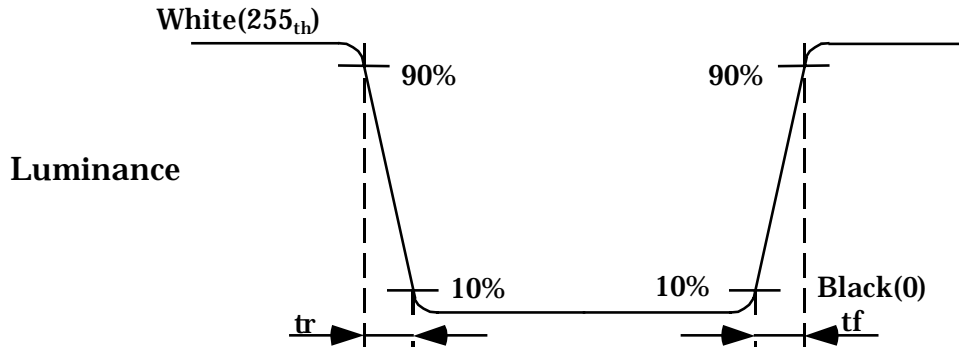

*5) Definition of Response Time(Gray Scale Level between 32th and 224th at intervals of 32 levels)

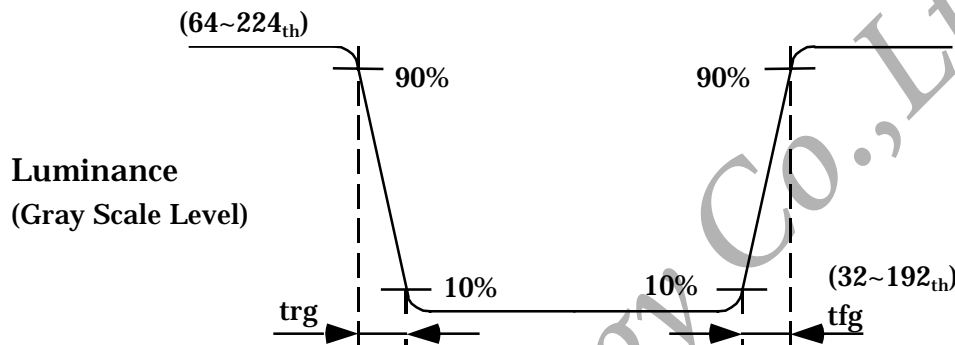

*6) Definition of Cross talk Ratio:

$$CTR(W)=MAX(| ((Lb2-La)/Lc) \times 100 |)$$

$$CTR(B)=MAX(| ((Lb1-La)/Lc) \times 100 |)$$

$$CTR(W-B)=MAX(| ((Lb1-La)/Lc) \times 100 - ((Lb2-La)/Lc) \times 100 |)$$

La : Luminance in 127 gray level raster display(Pattern a)

Lb1 ; Lb2 : Luminance under Pattern b1, b2(Back ground : 127 gray level)

Lc : Luminance in White raster display(Pattern c)

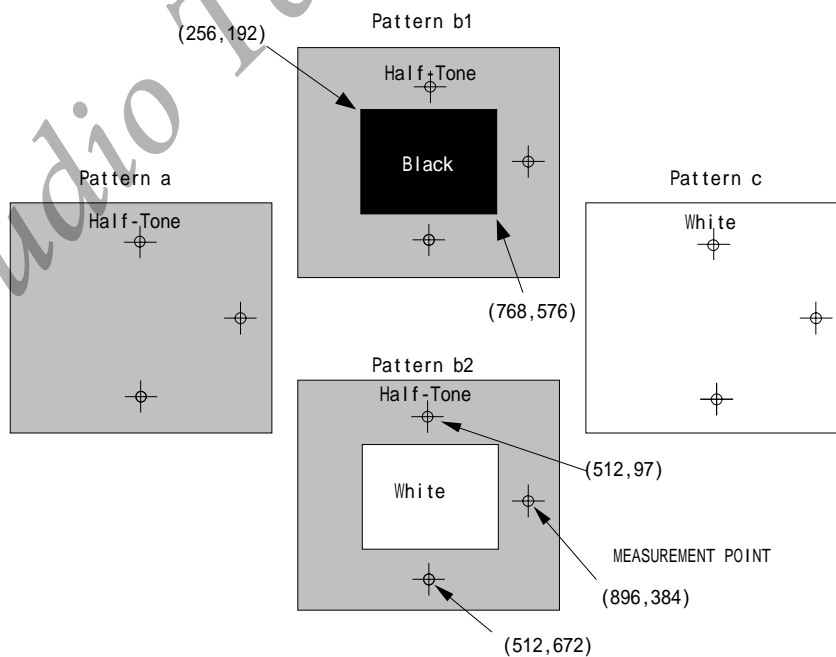

CROSS TALK Measurement Pattern

*7) Definition of Color Gamut :

A_{RGB} : Triangle area is measuring center point RGB color temperature at CIE color coordinates.

N_{RGB} : Triangle area is NTSC RGB color temperature at CIE color coordinates.

$$CG = \frac{A_{RGB}}{N_{RGB}} \times 100$$

9.RELIABILITY TEST CONDITIONS

(1)Temperature and Humidity

TEST ITEMS	CONDITIONS
HIGH TEMPERATURE HIGH HUMIDITY OPERATION	40 ; 90%RH; 240h (No condensation)
HIGH TEMPERATURE OPERATION	50 ; 240h
LOW TEMPERATURE STORAGE	-20 ; 240h
LOW TEMPERATURE OPERATION	0 ; 240h
HIGH TEMPERATURE STORAGE	60 ; 240h
THERMAL SHOCK	BETWEEN -20 (1hr)AND 60 (1hr); 100 CYCLES

(2)Shock & Vibration

ITEMS	CONDITIONS
SHOCK (NON-OPERATION)	Shock level:1470m/s ² (150G) Waveform: half sinusoidal wave, 2ms Number of shocks: one shock input in each direction of three mutually perpendicular axes for a total of six shock inputs
	Shock level:480m/s ² (50G) Waveform: half sinusoidal wave, 11ms Number of shocks: one shock input in each direction of three mutually perpendicular axes for a total of six shock inputs
VIBRATION (NON-OPERATION)	Vibration level: 9.8m/s ² (1.0G) zero to peak Waveform: sinusoidal Frequency range: 5 to 500 Hz Frequency sweep rate: 0.5 octave/min Duration: one sweep from 5 to 500 to 5 Hz in each of three mutually perpendicular axis(each x,y,z axis: 1 hour, total 3 hours)

(3)Judgment standard

The judgment of the above test should be made as follow:

Pass: Normal display image with no obvious non-uniformity and no line defect. Partial transformation of the module parts should be ignored.

Fail: No display image, obvious non-uniformity, or line defects.

10. HANDLING PRECAUTIONS FOR TFT-LCD MODULE

Please pay attention to the followings in handling- TFT-LCD products;

1 ASSEMBLY PRECAUTION

- (1) Please use the mounting hole on the module side in installing and do not beading or wrenching LCD in assembling. And please do not drop, bend or twist LCD module in handling.
- (2) Please design display housing in accordance with the following guide lines.
 - (2.1) Housing case must be destined carefully so as not to put stresses on LCD all sides and not to wrench module. The stresses may cause non-uniformity even if there is no non-uniformity statically.
 - (2.2) Keep sufficient clearance between LCD module back surface and housing when the LCD module is mounted. Approximately 1.0 mm of the clearance in the design is recommended taking into account the tolerance of LCD module thickness and mounting structure height on the housing.
 - (2.3) When some parts, such as, FPC cable and ferrite plate, are installed underneath the LCD module, still sufficient clearance is required, such as 0.5mm. This clearance is, especially, to be reconsidered when the additional parts are implemented for EMI countermeasure.
 - (2.4) Design the inverter location and connector position carefully so as not to give stress to lamp cable, or not to interface the LCD module by the lamp cable.
 - (2.5) Keep sufficient clearance between LCD module and the others parts, such as inverter and speaker so as not to interface the LCD module. Approximately 1.0mm of the clearance in the design is recommended.
- (3) Please do not push or scratch LCD panel surface with any-thing hard. And do not soil LCD panel surface by touching with bare hands. (Polarizer film, surface of LCD panel is easy to be flawed.)
- (4) Please do not press any parts on the rear side such as source TCP, gate TCP, control circuit board and FPCs during handling LCD module. If pressing rear part is unavoidable, handle the LCD module with care not to damage them.
- (5) Please wipe out LCD panel surface with absorbent cotton or soft cloth in case of it being soiled.
- (6) Please wipe out drops of adhesives like saliva and water on LCD panel surface immediately. They might damage to cause panel surface variation and color change.
- (7) Please do not take a LCD module to pieces and reconstruct it. Resolving and reconstructing modules may cause them not to work well.
- (8) Please do not touch metal frames with bare hands and soiled gloves. A color change of the metal frames can happen during a long preservation of soiled LCD modules.
- (9) Please pay attention to handling lead wire of backlight so that it is not tugged in connecting with inverter.

2 OPERATING PRECAUTIONS

- (1) Please be sure to turn off the power supply before connecting and disconnecting signal input cable.
- (2) Please do not change variable resistance settings in LCD module. They are adjusted to the most suitable value. If they are changed, it might happen LCD does not satisfy the characteristics specification.
- (3) Please consider that LCD backlight takes longer time to become stable of radiation characteristics in low temperature than in room temperature.
- (4) A condensation might happen on the surface and inside of LCD module in case of sudden change of ambient temperature.
- (5) Please pay attention to displaying the same pattern for very long time. Image might stick on LCD. If then, time going on can make LCD work well.
- (6) Please obey the same caution descriptions as ones that need to pay attention to ordinary electronic parts.

3 PRECAUTIONS WITH ELECTROSTATICS

- (1) This LCD module uses CMOS-IC on circuit board and TFT-LCD panel, and so it is easy to be affected by electrostatics. Please be careful with electrostatics by the way of your body connecting to the ground and so on.
- (2) Please remove protection film very slowly on the surface of LCD module to prevent from electrostatics occurrence.

4 STORAGE PRECAUTIONS

- (1) When you store LCDs for a long time, it is recommended to keep the temperature between 0 ~40 without the exposure of sunlight and to keep the humidity less than 90%RH.
- (2) Please do not leave the LCDs in the environment of high humidity and high temperature such as 60°C 90%RH.
- (3) Please do not leave the LCDs in the environment of low temperature; below -20 .

5 SAFETY PRECAUTIONS

- (1) When you waste LCDs, it is recommended to crush damaged or unnecessary LCDs into pieces and wash them off with solvents such as acetone and ethanol, which should later be burned.
- (2) If any liquid leaks out of a damaged-glass cell and comes in contact with the hands, wash off thoroughly with soap and water.

6 OTHERS

- (1) A strong incident light into LCD panel might cause display characteristics' changing inferior because of polarizer film, color filter, and other materials becoming inferior. Please do not expose LCD module direct sunlight and strong UV rays.
- (2) Please pay attention to a panel side of LCD module not to contact with other materials in preserving it alone.
- (3) For the packaging box, please pay attention to the followings:
 - (3.1) Packaging box and inner case for LCD are designed to protect the LCDs from the damage or scratching during transportation. Please do not open except picking LCDs up from the box.
 - (3.2) Please do not pile them up more than 5 boxes. (They are not designed so.) And please do not turn over.
 - (3.3) Please handle packaging box with care not to give them sudden shock and vibrations. And also please do not throw them up.
 - (3.4) Packing box and inner case for LCDs are made of cardboard. So please pay attention not to get them wet. (Such like keeping them in high humidity or wet place can occur getting them wet.)