



# Chunghwa Picture Tubes, Ltd.

## Technical Specification

To : SCL  
Date : 2011/02/15

**TFT LCD**  
**CLAA133WB01A**

ACCEPTED BY :

APPROVED BY	CHECKED BY	PREPARED BY
Ronald Huang	Roger Liu	Carol Shen

Prepared by :

Product Planning Management Division  
VD Business Unit

**CHUNGHWA PICTURE TUBES, LTD.**

1127 Hopin Rd., Padeh, Taoyuan, Taiwan 334, R.O.C.  
TEL: +886-3-3675151 FAX: +886-3-377--3003

Doc.No:	CLAA133WB01A-SCL-T1-20110215	Issue Date:	20110215
---------	------------------------------	-------------	----------



CPT

CHUNGHWA PICTURES TUBES, LTD.,

**RECORD OF REVISIONS**

<b>Revision No.</b>	<b>Date</b>	<b>Description</b>
<b>T1</b>	<b>2011/02/15</b>	<b>Tentative</b>

www.panelook.com

**CONTENTS**

<b>NO.</b>	<b>ITEM</b>	<b>Page</b>
1	OVERVIEW	4
2	ABSOLUTE MAXIMUM RATINGS	5
3	ELECTRICAL CHARACTERISTICS	6
4	CONNECTOR INTERFACE PIN & FUNCTION	11
5	INTERFACE TIMING CHART	12
6	BLOCK DIAGRAM	15
7	MECHANICAL SPECIFICATION	16
8	OPTICAL CHARACTERISTICS	18
9	RELIABILITY TEST CONDITIONS	21
10	HANDLING PRECAUTIONS FOR TFT-LCD MODULE	22

## 1. OVERVIEW

**CLAA133WB01A** is 13.3" color (16 : 9) TFT-LCD (Thin Film Transistor Liquid Crystal Display) module composed of LCD panel, LVDS driver ICs, control circuit and backlight. By applying 6 bit digital data, 1366×RGB (3) ×768, 262K-color images are displayed on the 13.3" diagonal screen. General specifications are summarized in the following table :

ITEM	SPECIFICATION
Display Area	293.417(H)×164.966(V)(mm) (13.3-inch diagonal)
Number of Pixels	1366×3(H)×768(V)
Pixel Pitch	0.2148(H)×0.2148(V) (mm)
Color Pixel Arrangement	RGB island
Display Mode	Normally white
Number of Colors	262,144(6bits) (LVDS)
Gamut	42%(min)/45% (Typ)
Optimum Viewing Angle	6 o'clock
Response Time	8ms (Typ)
Surface Treatment	Glare
Viewing Angle	40°、40°/15°、30° (Min)
Brightness	200 cd/m2 (5point) (Typ)
Uniformity	5point : 80%
Consumption of Power	3.6 W (Max)
Module Size	306.8(W)×189.25(H)×3.6(D) (mm) ( Max)
Module Weight	290 g (Max)

The LCD Products listed on this document are not suitable for use of aerospace equipment, submarine cable, and nuclear reactor control system and life support systems. If customers intend to use these LCD products for applications listed above or those not included in the "Standard" list as follows, please contact our sales in advance.

Standard : Computer, Office equipment, Communication equipment, Test and Measurement equipment, Machine tool, Industrial robot, Audio and Visual equipment, Other consumer products.

## 2. ABSOLUTE MAXIMUM RATINGS

The following are maximum value, which if exceeded, may cause faulty operation or damage to the unit.

ITEM	SYMBOL	MIN	MAX	UNIT	NOTE
LCD Power Voltage	VCC	0	4.0	V	
LED Driver Input Voltage	VBL+	7	21	V	
Operation Temperature	Top	0	50	°C	*1).*2).*3).*4)
Storage Temperature	Tstg	-25	65	°C	*1).*2).*3)

### 【Note】

- \*1) The relative temperature and humidity range are as below sketch, 90%RH Max. ( $T_a \leq 40^\circ\text{C}$ )
- \*2) The maximum wet bulb temperature  $\leq 39^\circ\text{C}$  ( $T_a > 40^\circ\text{C}$ ) and without dewing.
- \*3) If product in environment which over the definition of the relative temperature and humidity out of range too long, it will affect visual of LCD.
- \*4) If you operate LCD in normal temperature range, the center surface of panel should be under  $50^\circ\text{C}$ .

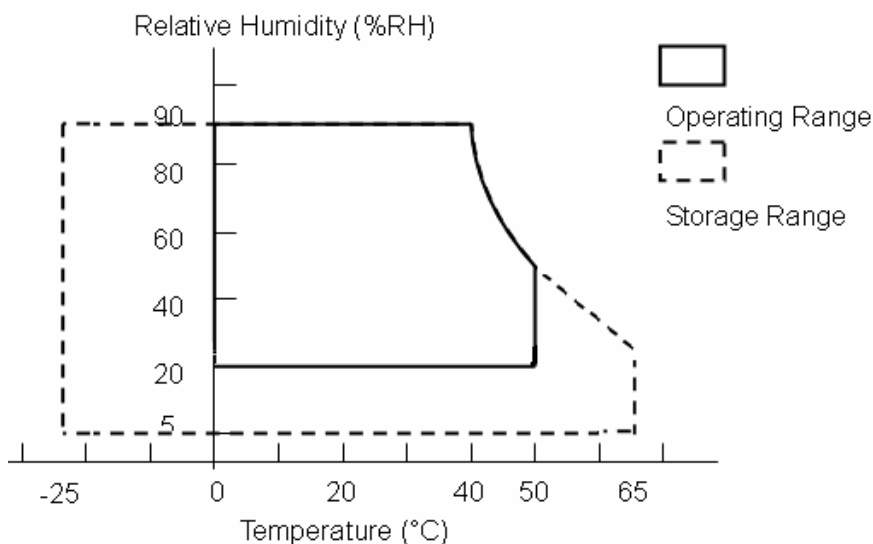

### 3. ELECTRICAL CHARACTERISTICS

#### (A) TFT LCD

ITEM	SYMBOL	MIN	TYP	MAX	UNIT	NOTE	
LCD Power Voltage	VCC	3.0	3.3	3.6	V	*1)	
LCD Power Current	ICC	-	240	300	mA	*2)	
Rush Current	Irush	-	-	2	A	*4)	
Logic Input Voltage (LVDS: IN+,IN-)	Common Voltage	VCM	1.125	1.25	1.375	V	*3)
	Differential Input Voltage	VID	250	350	450	mV	*3)
	Threshold Voltage (HIGH)	VTH	-	-	100	mV	*3)
	Threshold Voltage (LOW)	VTL	-100	-	-	mV	When VCM = +1.2V

#### 【Note】

\*1) Power Sequence :

$$0.50 \text{ ms} \leq t1 \leq 10 \text{ ms}$$

$$0.01 \text{ ms} < t2 \leq 50 \text{ ms}$$

$$0.01 \text{ ms} < t3 \leq 50 \text{ ms}$$

$$500 \text{ ms} \leq t4$$

$$200 \text{ ms} \leq t5$$

$$200 \text{ ms} \leq t6$$

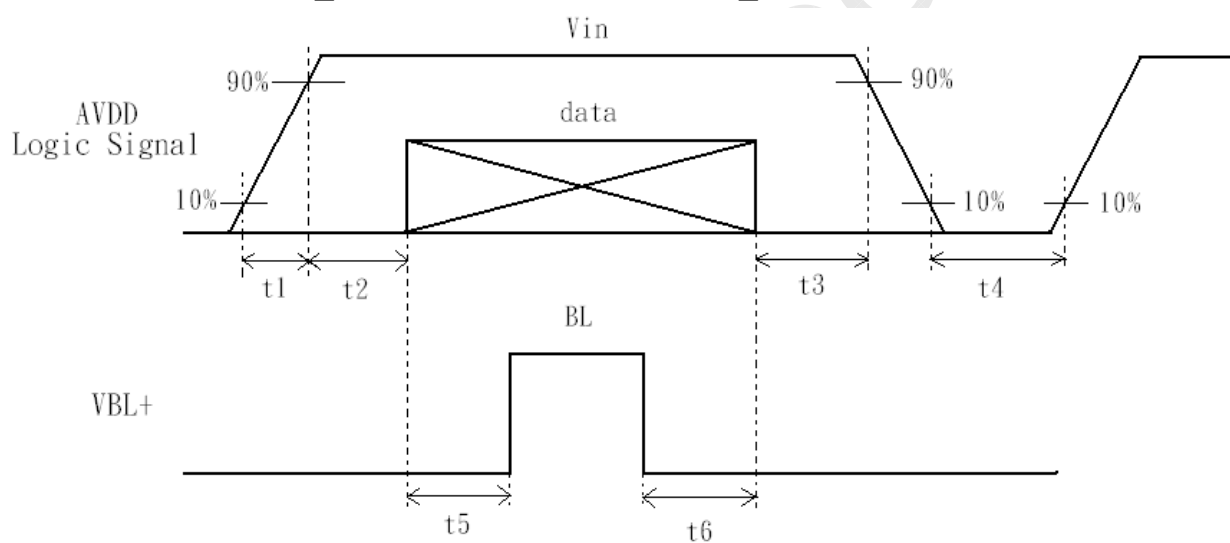

data: RGB DATA, DCLK, HD, VD, DENA

## VCC-dip state

(1) when  $3.0V > VCC \geq 2.7V$ ,  $t_d \leq 10$  ms.

(2) when  $VCC < 2.7V$ , VCC-dip condition should as the VCC-turn-off condition.

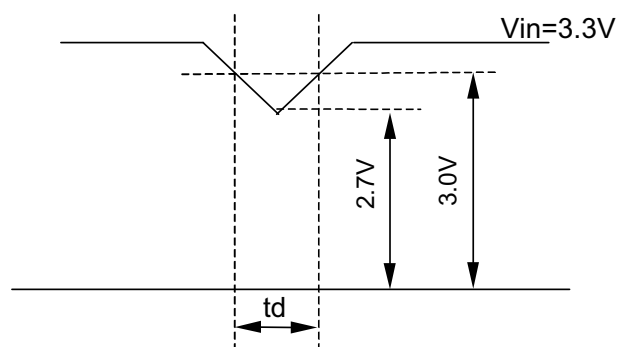

\*2) Typical value is Mosaic (32\*36 Checker board) Pattern : 768 line mode.

Circuit condition (Typ) :  $VCC=3.3$  V ,  $f_V=60$  Hz  $f_H=48.36$  kHz ,  $f_{CLK}=75.44$  MHz (one of LVDS dual port).

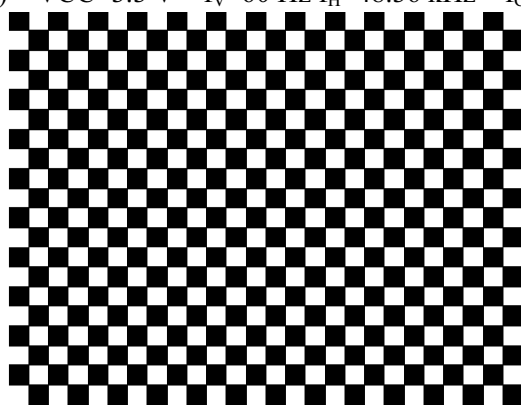

Max value is Black Pattern : 768 line mode.

Circuit condition (Max) :  $VCC=3.3$  V ,  $f_V=60$  Hz  $f_H=48.36$  kHz ,  $f_{CLK}=75.44$  MHz (one of LVDS dual port).

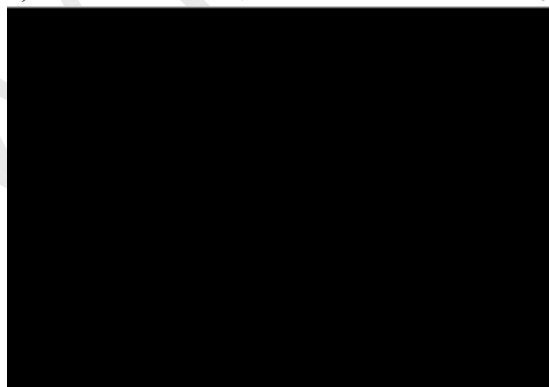

CPT

CHUNGHWA PICTURES TUBES, LTD.,

\*3) LVDS Signal Definite :

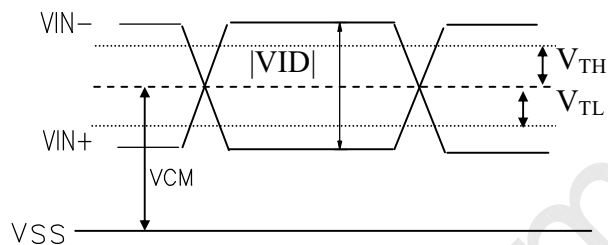
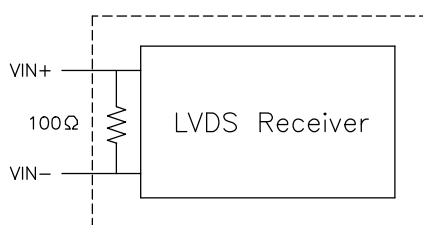

VIN+ : Positive differential DATA &amp; CLK Input

VIN- : Negative differential DATA &amp; CLK Input

\*4) Irush measure condition

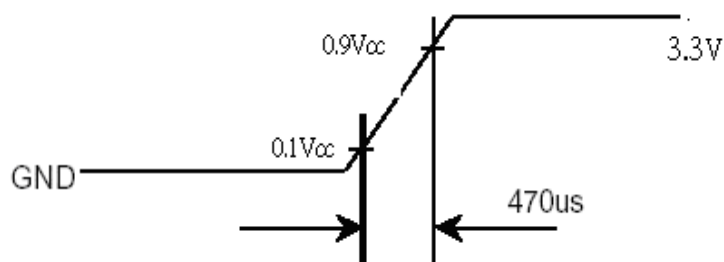
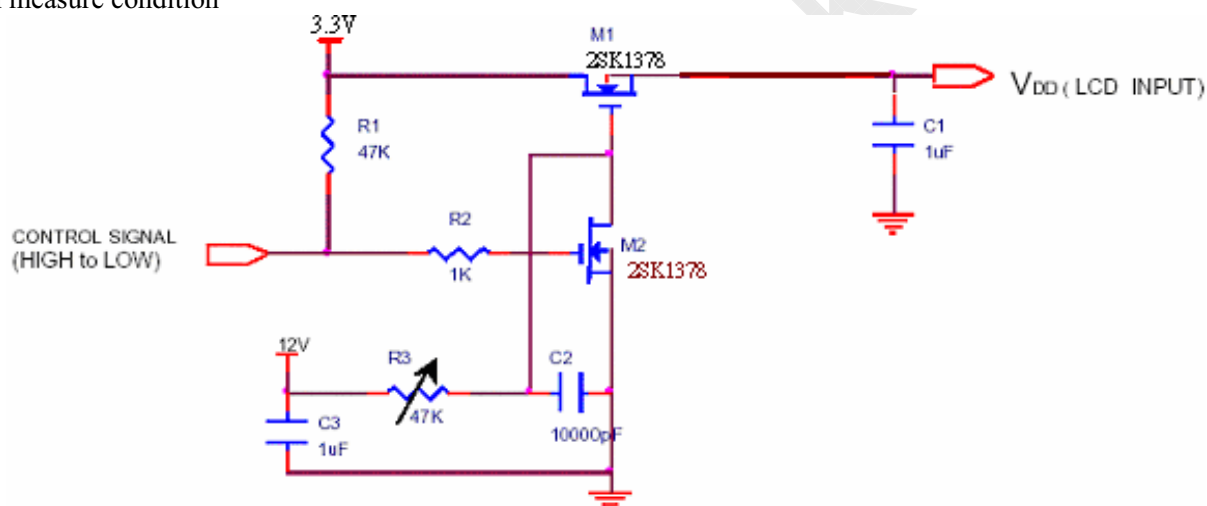



**(B) BACK LIGHT**

## (a) ELECTRICAL CHARACTERISTICS

Ta=25°C

ITEM	SYMBOL	MIN	TYP	MAX	UNIT	NOTE
LED Driver Input Voltage	VBL+	7	12	21	V	
LED Driver Input Current	IBL+	-	190	380	mA	*1)
Forward Voltage	V <sub>F</sub>	2.9	3.2	3.5	V	*2) I <sub>F</sub> =16.5mA
Forward Current	I <sub>F</sub>	16	16.5	17	mA	*2) I <sub>F</sub> =16.5mA
Power Consumption	PLED	2.2	2.4	2.6	W	*2)*3) I <sub>F</sub> =16.5mA
PWM Frequency	PWM_BL	180	200	1000	Hz	
Duty ratio	Dim	10	-	100	%	

## (b) LED LIFE – TIME

ITEM	CONDITION	MIN	TYP	MAX	UNIT	NOTE
Life Time	I <sub>F</sub> =20mA、Ta=25°C	15000			hrs	*4)

## (c) LED ON/OFF Sequence :

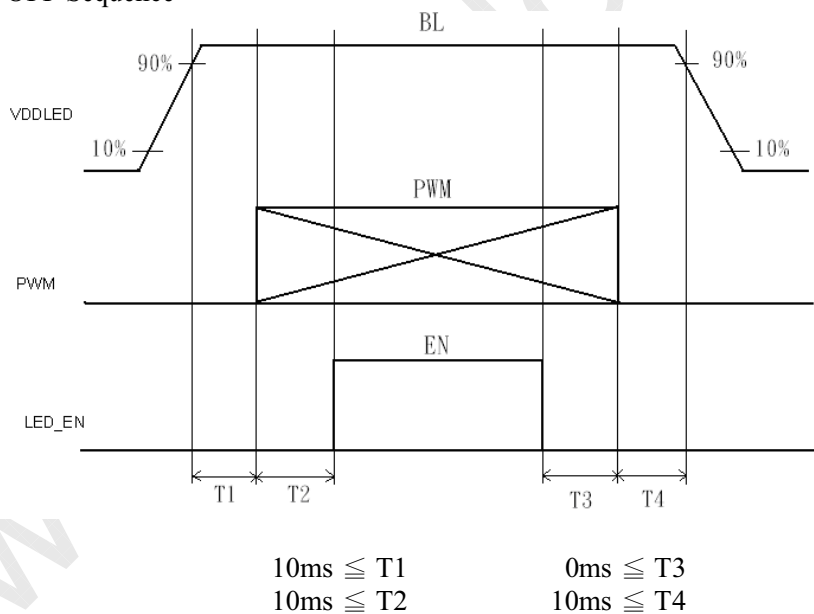

Note : The duty of LED dimming signal should be more than 20% in T2 and T3

- \*1) Maximum LED Driver Input Current at 7V Input Voltage/PWM Duty 100%.
- \*2) Measure method : a. LED current is measured by utilizing a current meter as show below.  
b. System power PLED is measured at input voltage 12V.

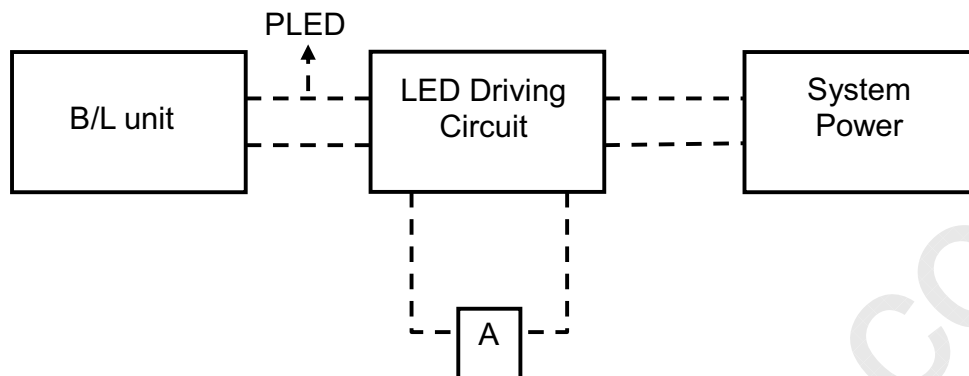

- \*3) Calculator value for reference  $I_F \times V_F \times N = P_{LED}$
- \*4) Life time means that estimated time to 50% degradation of initial luminous intensity.

#### 4. Connector Interface PIN & Function

##### CN (Interface signal)

Outlet connector: 20455-040E-12 (I-PEX) or equivalent

Pin No.	SYMBOL	FUNCTION
1	NC	No Connect
2	VDD	Power Supply, 3.3 V (typical)
3	VDD	Power Supply, 3.3 V (typical)
4	V EEDID	DDC 3.3V power
5	NC	No Connect
6	Clk EEDID	DDC Clock
7	DATA EEDID	DDC Data
8	Odd_Rin0-	- LVDS differential data input (R0-R5, G0) (odd pixels)
9	Odd_Rin0+	+ LVDS differential data input (R0-R5, G0) (odd pixels)
10	VSS	Ground – Shield
11	Odd_Rin1-	- LVDS differential data input (G1-G5, B0-B1) (odd pixels)
12	Odd_Rin1+	+ LVDS differential data input (G1-G5, B0-B1) (odd pixels)
13	VSS	Ground – Shield
14	Odd_Rin2-	- LVDS differential data input (B2-B5, HS, VS, DE) (odd pixels)
15	Odd_Rin2+	+ LVDS differential data input (B2-B5, HS, VS, DE) (odd pixels)
16	VSS	Ground – Shield
17	Odd_CIKIN-	- LVDS differential clock input (odd pixels)
18	Odd_CIKIN+	+ LVDS differential clock input (odd pixels)
19	NC	No Connect
20	NC	No connection(Please let it floating for CPT test only)
21	NC	No connection(Please let it floating for CPT test only)
22	VSS	Ground – Shield
23	NC	No connection(Please let it floating for CPT test only)
24	NC	No connection(Please let it floating for CPT test only)
25	VSS	Ground – Shield
26	NC	No connection(Please let it floating for CPT test only)
27	NC	No connection(Please let it floating for CPT test only)
28	VSS	Ground – Shield
29	NC	No connection(Please let it floating for CPT test only)
30	NC	No connection(Please let it floating for CPT test only)
31	VSSLED	Ground – LED
32	VSSLED	Ground – LED
33	VSSLED	Ground – LED
34	NC	No Connect
35	PWM	System PWM Signal Input (+3.3V Swing)
36	LED_EN	LED enable pin (+3.3V Input)
37	NC	No Connect
38	VDDLED	7V – 21V LED power
39	VDDLED	7V – 21V LED power
40	VDDLED	7V – 21V LED power

## 5. INTERFACE TIMING CHART

### (1)(a) LVDS input time sequence

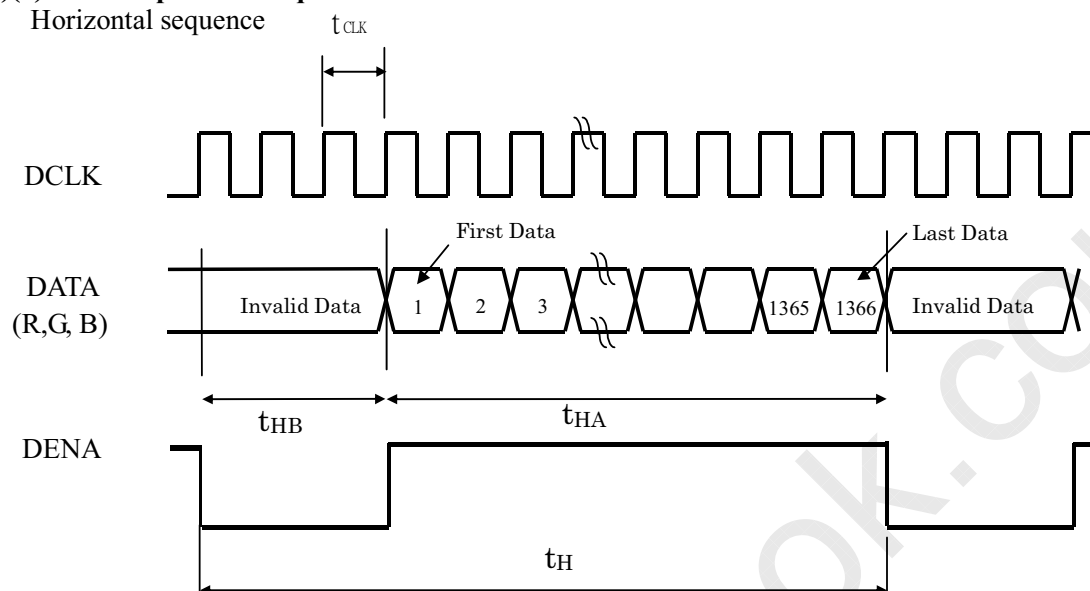

### (b) LCD input time sequence

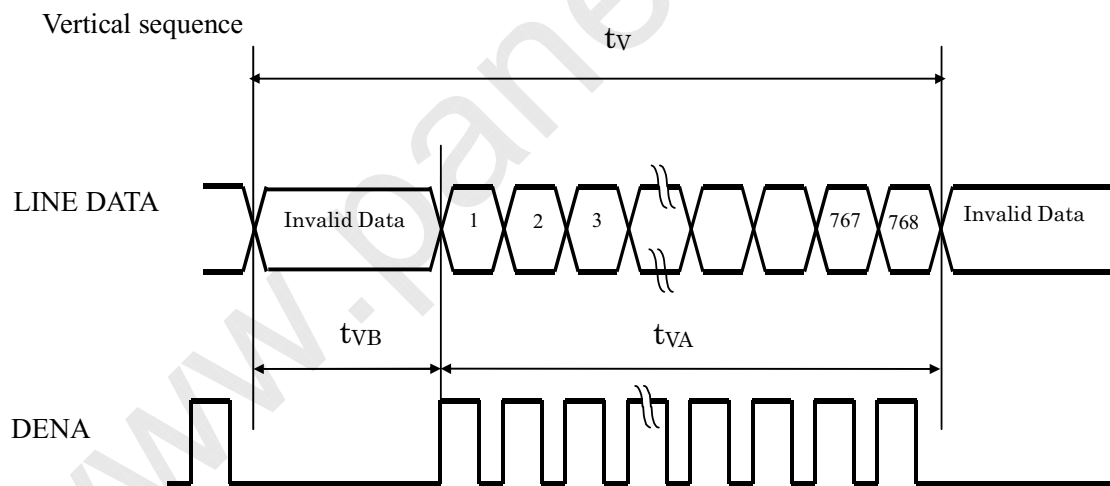

## (2) Timing Chart

ITEM		SYMBOL	MIN	TYP	MAX	UNIT		
LCD Timing	Frame Rate		-	55	60	60	Hz	
	DCLK	Frequency	$f_{CLK}$	65.93	75.44	80	MHz	
		Period	$t_{CLK}$	15.17	13.25	15.83	ns	
	DENA	Horizontal	Horizontal Total time	$t_H$	1480	1560	1700	$t_{CLK}$
			Horizontal Active time	$t_{HA}$	1366	1366	1366	$t_{CLK}$
			Horizontal Blank time	$t_{HB}$	114	194	334	$t_{CLK}$
		Vertical	Vertical Total time	$t_V$	766	806	870	$t_H$
			Vertical Active time	$t_{VA}$	768	768	768	$t_H$
			Vertical Blank time	$t_{VB}$	8	38	102	$t_H$
LVDS Spread Spectrum Range *3)				-2		2	%	

## 【Note】

- \*1) DENA (DATA ENABLE) usually is positive.
- \*2) During the whole blank period, DCLK should keep input.
- \*3) LVDS input clock is 85MHz and modulation rate is fixed 300KHz

CPT

CHUNGHWA PICTURES TUBES, LTD.,

## (3) DATA mapping

Color	Input Data	R DATA						G DATA						B DATA						
		R5	R4	R3	R2	R1	R0	G5	G4	G3	G2	G1	G0	B5	B4	B3	B2	B1	B0	
		MS B					LS B	MS B					LS B	MS B					LS B	
Basic Color	Black	0	0	0	0	0	0	0	0	0	0	0	0	0	0	0	0	0	0	0
	Red(63)	1	1	1	1	1	1	0	0	0	0	0	0	0	0	0	0	0	0	0
	Green(63)	0	0	0	0	0	0	1	1	1	1	1	1	0	0	0	0	0	0	0
	Blue(63)	0	0	0	0	0	0	0	0	0	0	0	0	1	1	1	1	1	1	1
	Cyan	0	0	0	0	0	0	1	1	1	1	1	1	1	1	1	1	1	1	1
	Magenta	1	1	1	1	1	1	0	0	0	0	0	0	1	1	1	1	1	1	1
	Yellow	1	1	1	1	1	1	1	1	1	1	1	1	0	0	0	0	0	0	0
	White	1	1	1	1	1	1	1	1	1	1	1	1	1	1	1	1	1	1	1
RED	RED(0)	0	0	0	0	0	0	0	0	0	0	0	0	0	0	0	0	0	0	0
	RED(1)	0	0	0	0	0	1	0	0	0	0	0	0	0	0	0	0	0	0	0
	RED(2)	0	0	0	0	1	0	0	0	0	0	0	0	0	0	0	0	0	0	0
	RED(62)	1	1	1	1	1	0	0	0	0	0	0	0	0	0	0	0	0	0	0
	RED(63)	1	1	1	1	1	1	0	0	0	0	0	0	0	0	0	0	0	0	0
Green	Green(0)	0	0	0	0	0	0	0	0	0	0	0	0	0	0	0	0	0	0	0
	Green(1)	0	0	0	0	0	0	0	0	0	0	1	0	0	0	0	0	0	0	0
	Green(2)	0	0	0	0	0	0	0	0	0	1	0	0	0	0	0	0	0	0	0
	Green(62)	0	0	0	0	0	0	1	1	1	1	1	0	0	0	0	0	0	0	0
	Green(63)	0	0	0	0	0	0	1	1	1	1	1	1	0	0	0	0	0	0	0
Blue	Blue(0)	0	0	0	0	0	0	0	0	0	0	0	0	0	0	0	0	0	0	0
	Blue(1)	0	0	0	0	0	0	0	0	0	0	0	0	0	0	0	0	0	1	0
	Blue(2)	0	0	0	0	0	0	0	0	0	0	0	0	0	0	0	0	1	0	0
	Blue(62)	0	0	0	0	0	0	0	0	0	0	0	0	1	1	1	1	1	1	0
	Blue(63)	0	0	0	0	0	0	0	0	0	0	0	0	1	1	1	1	1	1	1

## 【Note】

- 1) Gray level:  
Color(n) : n is level order; higher n means brighter level.
- 2) DATA:  
1: high , 0: low

## 6. BLOCK DIAGRAM

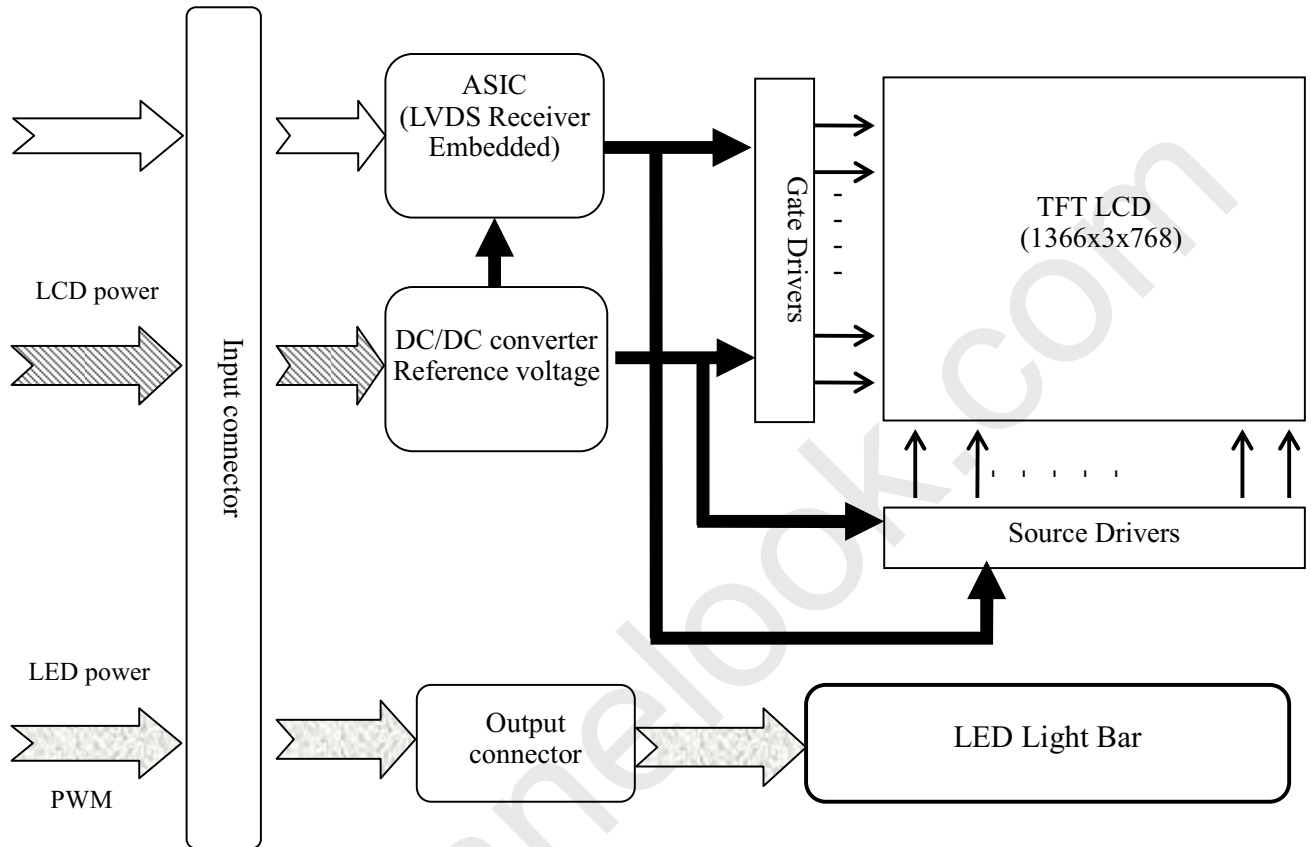

CPT

CHUNGWA PICTURES TUBES, LTD.,

## 7. MECHANICAL SPECIFICATION

### (1) Front side

The tolerance, not show in the figure, is  $\pm 0.5$  mm.

[Unit : mm]

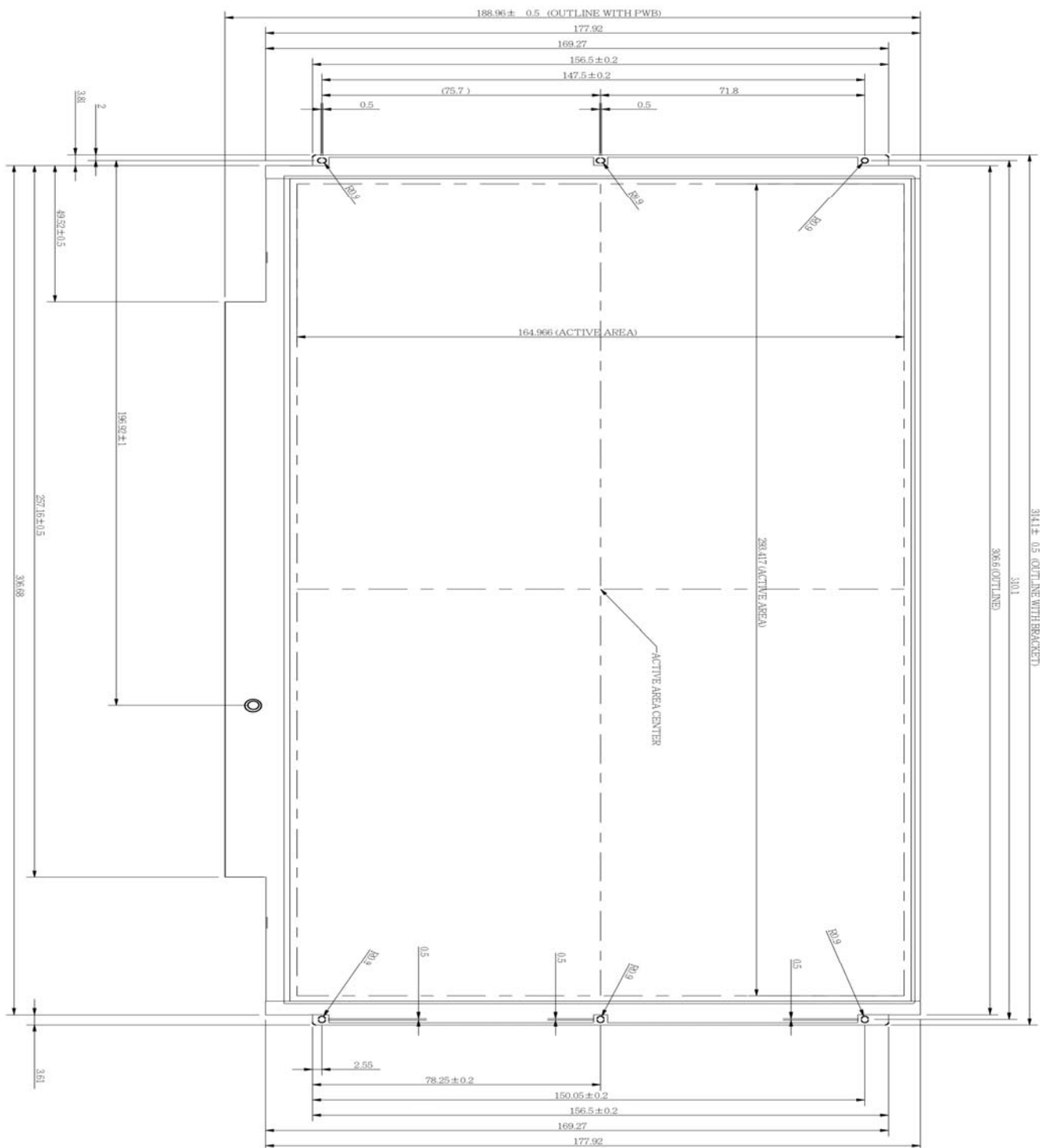



CPT

CHUNGHWA PICTURES TUBES, LTD.,

**(2) Rear side**The tolerance, not show in the figure, is  $\pm 0.5$  mm.

[Unit : mm]

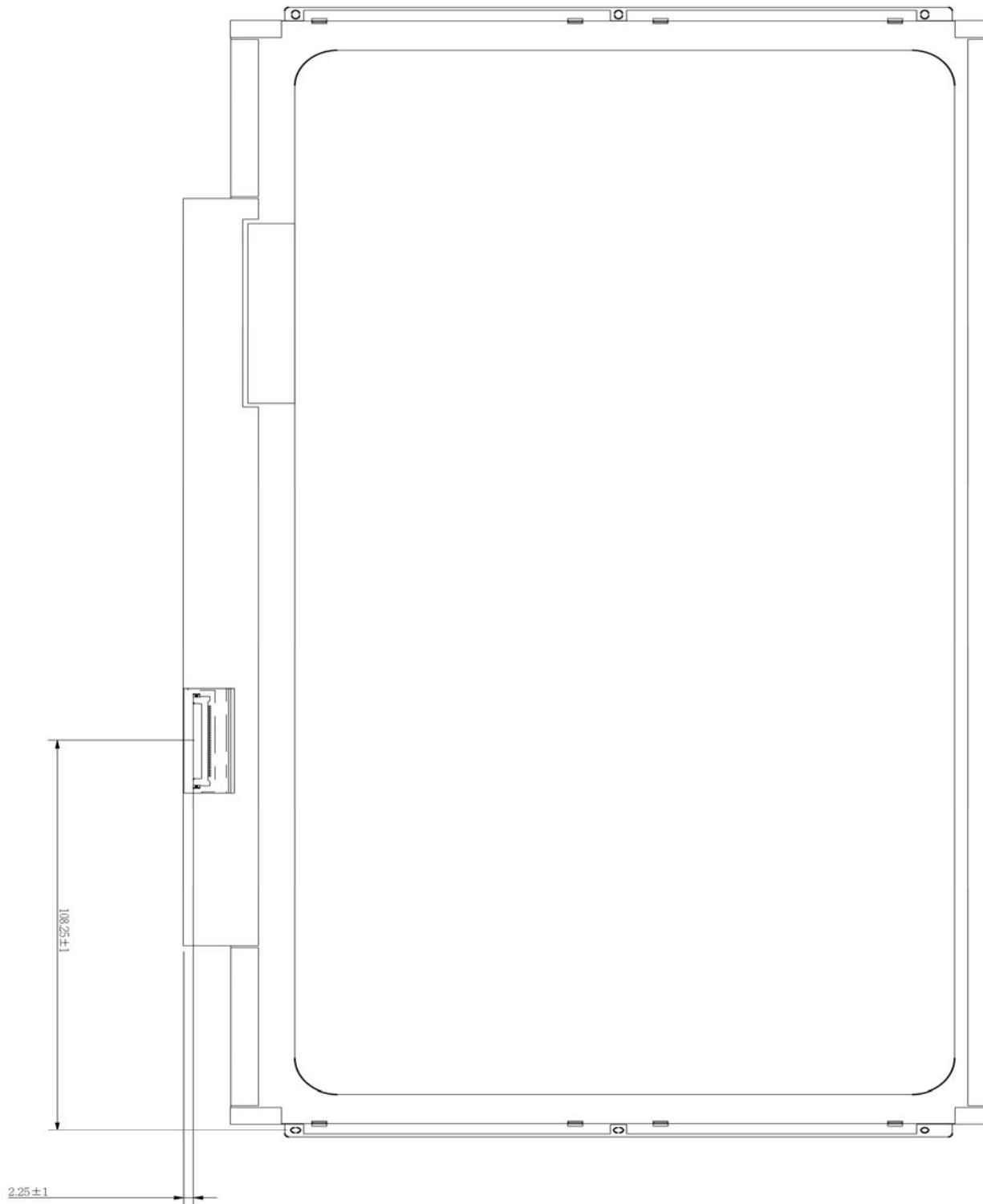

## 8. OPTICAL CHARACTERISTICS

Ta=25°C , VDD=3.3V

ITEM	SYMBOL	CONDITION	MIN	TYP	MAX	UNIT	NOTE	
Contrast Ratio	CR	$\theta = \psi = 0^\circ$	500	600		--	*1) 2)	
Luminance (5P)	L	$\theta = \psi = 0^\circ$	175	200		cd/m <sup>2</sup>	*1) 3)	
Uniformity(5P)	$\Delta L$	$\theta = \psi = 0^\circ$	80			%	*1) 3)	
Response Time	Tr	$\theta = \psi = 0^\circ$		8	16	ms	*5)	
	Tf	$\theta = \psi = 0^\circ$				ms	*5)	
Cross Talk	CT	$\theta = \psi = 0^\circ$			1	%	*6)	
View Angle	Horizontal	$\psi$	$CR \geq 10$	40/-40		°	*4)	
	Vertical	$\theta$		15/-30		°	*4)	
Color Coordinate	W	x	$\theta = \psi = 0^\circ$	0.283	0.313	0.343	Color Coordinates	*3)
		y		0.299	0.329	0.359		
	R	x		0.550	0.580	0.610		
		y		0.310	0.340	0.370		
	G	x		0.280	0.310	0.340		
		y		0.520	0.550	0.580		
B	x	0.125	0.155	0.185				
	y	0.095	0.125	0.155				
Gamut		$\theta = \psi = 0^\circ$	42	45		%		

Color coordinate and color gamut are measured by SRUL1R, response time is measured by TRD-100, and all the other items are measured by BM-5A (TOPCON). All these items are measured under the dark room condition (no ambient light).  
Measurement Condition: IL= 19mA (each LED)

**Definition of these measurement items is as follows:****\*1) Setup of Measurement Equipment**

The LCD module should be turn-on to a stable luminance level to be reached. The measurement should be executed after lighting Backlight for 20 minutes and in a dark room.

**\*2) Definition of Contrast Ratio**

CR=ON (White) Luminance/OFF (Black) Luminance

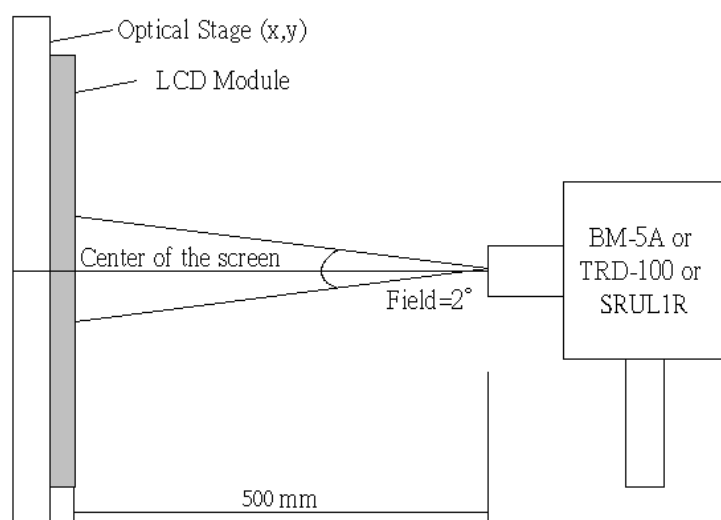

### \*3) Definition of Luminance and Luminance uniformity

Central luminance: The white luminance is measured at the center position "5" on the screen, see Fig.1 below.

5P Luminance (AVG): The white luminance is measured at measuring points 5、10、11、12、13, see Fig.1 below.

5P Uniformity:  $\Delta L = (L_{min} / L_{max}) \times 100\%$

13P Uniformity:  $\Delta L = (L_{min} / L_{max}) \times 100\%$

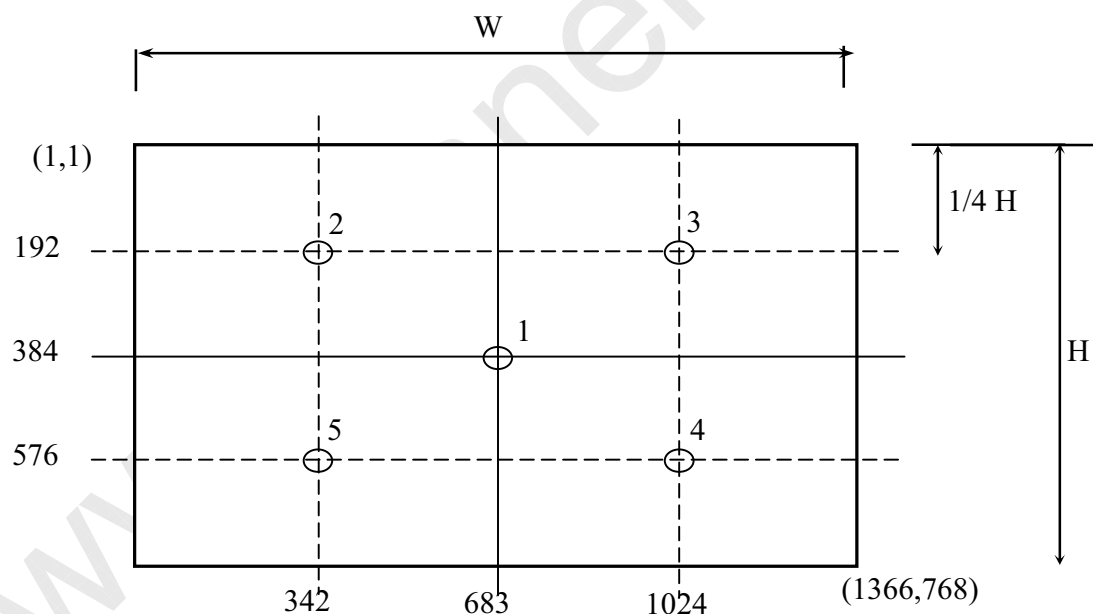

**\*4) Definition of view angle( $\theta$  ,  $\psi$ )**

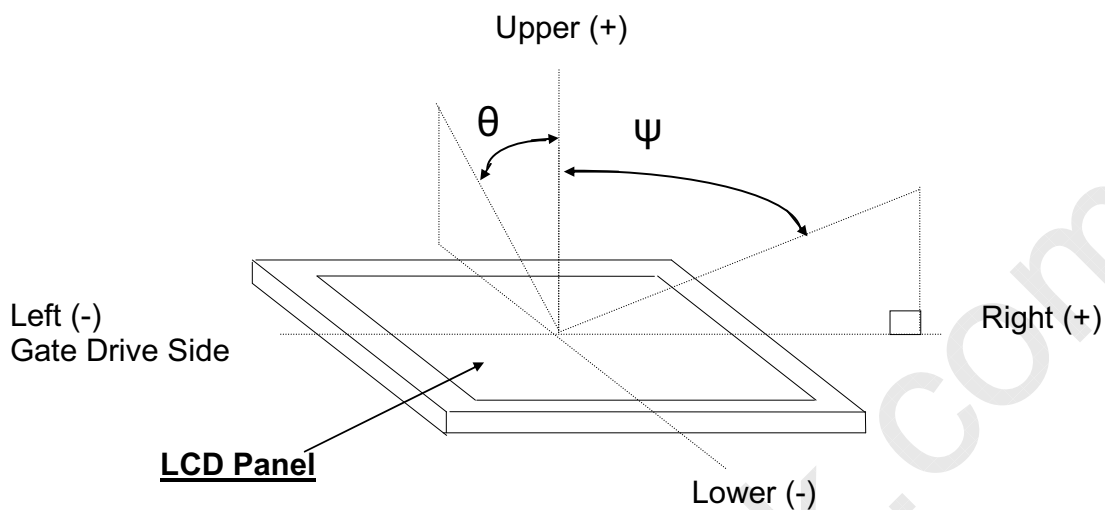

**\*5) Definition of response time**

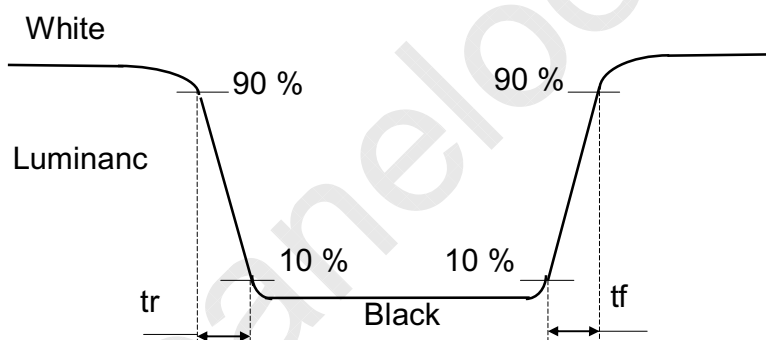

**\*6) Crosstalk Modulation Ratio**

$$CT = | Y_B - Y_A | / Y_{Ax} \times 100\%$$

$Y_A$  ,  $Y_B$  measure position and definition

$Y_A$  means luminance at gray level 31(exclude gray level 0 pattern)

$Y_B$  means luminance at gray level 31(include gray level 0 pattern)

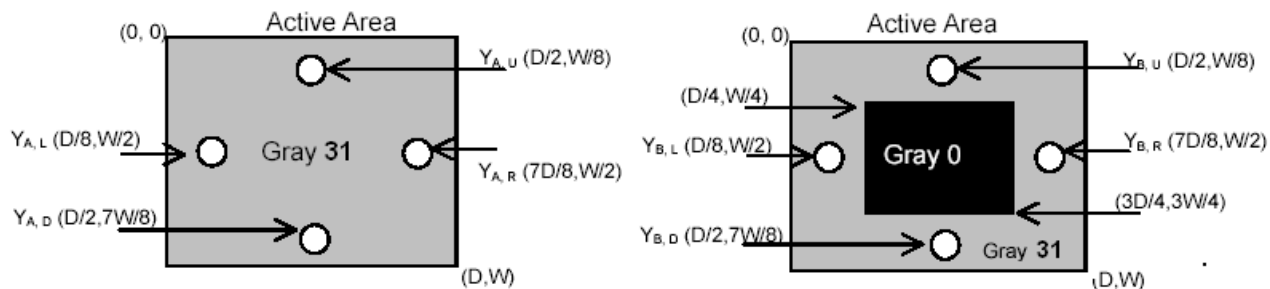

## 9. RELIABILITY TEST CONDITIONS

### (1) Temperature and Humidity

TEST ITEMS	CONDITIONS
High Temperature Operation	50° C ; 250Hrs
High Temperature Storage	65° C ; 250Hrs
High Temperature High Humidity Operation	40° C ; 95% RH ; 250Hrs
High Temperature High Humidity Storage	60° C ; 90% RH ; 48 Hrs
Low Temperature Operation	0° C ; 250 Hrs
Low Temperature Storage	-30° C ; 250 Hrs
Thermal Shock	-40° C (0.5 Hr)~65° C (0.5 Hr), Ramp<20° C , 100 CYCLES
Temperature & Pressure Storage	-30° C ; 260hPa , 24 Hrs

### (2) Shock & Vibration

TEST ITEMS	CONDITIONS
Shock (Non-Operation)	210G, 3ms, half sin ewave, ± X,± Y,± Z 1time each
Vibration (Non-Operation)	Vibration level : 14.7m/s <sup>2</sup> (1.5G), sinusoidal wave (each x, y, z axis : 1hr, total 3hrs) Frequency range : 5~500 Hz Sweep speed : 0.5 Octave/min.

### (3) ESD

	Surface discharge(Panel display area · Frame · PWB · Panel back side)		Electrics capacity of Connector
	Contact	Air	Contact
Capacity	150 pF	150 pF	200 pF
Resistance	330 Ω	330 Ω	0 Ω
Voltage	±8kV	±8kV/±15kV	±250 V
Interval	1 sec	1 sec	1 sec
Times(single point)	25	25	1

(4) MTBF without B/L: 200,000 Hrs (min) lifetimes.

### (5) Judgment standard

The judgment of the above test should be made as follow:

Pass : Normal display image with no obvious non-uniformity and no line defect.

Partial transformation of the module parts should be ignored.

Fail : No display image, obvious non-uniformity, or line defects.

## 10. HANDLING PRECAUTIONS FOR TFT-LCD MODULE

Please pay attention to the followings in handling- TFT-LCD products;

### 10.1 ASSEMBLY PRECAUTION

- (1) Please use the mounting hole on the module side in installing and do not beading or wrenching LCD in assembling. And please do not drop, bend or twist LCD module in handling.
- (2) Please design display housing in accordance with the following guidelines.
  - Housing case must be destined carefully so as not to put stresses on LCD all sides and not to wrench module. The stresses may cause non-uniformity even if there is no non-uniformity statically.
  - Keep sufficient clearance between LCD module back surface and housing when the LCD module is mounted. Approximately 1.0 mm of the clearance in the design is recommended taking into account the tolerance of LCD module thickness and mounting structure height on the housing.
  - When some parts, such as, FPC cable and ferrite plate, are installed underneath the LCD module, still sufficient clearance is required, such as 0.5mm. This clearance is, especially, to be reconsidered when the additional parts are implemented for EMI countermeasure.
  - Design the inverter location and connector position carefully so as not to give stress to lamp cable, or not to interface the LCD module by the lamp cable.
  - Keep sufficient clearance between LCD module and the others parts, such as inverter and speaker so as not to interface the LCD module. Approximately 1.0mm of the clearance in the design is recommended.
- (3) Please do not push or scratch LCD panel surface with any-thing hard. And do not soil LCD panel surface by touching with bare hands. (Polarizer film, surface of LCD panel is easy to be flawed.)
- (4) Please do not press any parts on the rear side such as source TCP, gate TCP, control circuit board and FPCs during handling LCD module. If pressing rear part is unavoidable, handle the LCD module with care not to damage them.
- (5) Please wipe out LCD panel surface with absorbent cotton or soft clothe in case of it being soiled.
- (6) Please wipe out drops of adhesives like saliva and water on LCD panel surface immediately. They might damage to cause panel surface variation and color change.
- (7) Please do not take a LCD module to pieces and reconstruct it. Resolving and reconstructing modules may cause them not to work well.
- (8) Please do not touch metal frames with bare hands and soiled gloves. A color change of the metal frames can happen during a long preservation of soiled LCD modules.
- (9) Please pay attention to handling lead wire of backlight so that it is not tugged in connecting with inverter.

### 10.2 OPERATING PRECAUTIONS

- (1) Please be sure to turn off the power supply before connecting and disconnecting signal input cable.
- (2) Please do not change variable resistance settings in LCD module. They are adjusted to the most suitable value. If they are changed, it might happen LCD does not satisfy the characteristics specification.
- (3) Please consider that LCD backlight takes longer time to become stable of radiation characteristics in low temperature than in room temperature.
- (4) A condensation might happen on the surface and inside of LCD module in case of sudden change of ambient temperature.
- (5) Please pay attention to displaying the same pattern for very long time. Image might stick on LCD. If then, time going on can make LCD work well.
- (6) Please obey the same caution descriptions as ones that need to pay attention to ordinary electronic parts.

### 10.3 PRECAUTIONS WITH ELECTROSTATICS

- (1) This LCD module use CMOS-IC on circuit board and TFT-LCD panel, and so it is easy to be affected by electrostatics. Please be careful with electrostatics by the way of your body connecting to the ground and so on.
- (2) Please remove protection film very slowly on the surface of LCD module to prevent from electrostatics occurrence.

### 10.4 STORAGE PRECAUTIONS

- (1) When you store LCDs for a long time, it is recommended to keep the temperature between 0°C ~40°C without the exposure of sunlight and to keep the humidity less than 90%RH.
- (2) Please do not leave the LCDs in the environment of high humidity and high temperature such as 60°C and 90%RH.
- (3) Please do not leave the LCDs in the environment of low temperature(below -20°C.)

### 10.5 SAFETY PRECAUTIONS

- (1) When you waste LCDs, it is recommended to crush damaged or unnecessary LCDs into pieces and wash them off with solvents such as acetone and ethanol, which should later be burned.
- (2) If any liquid leaks out of a damaged-glass cell and comes in contact with the hands, wash off thoroughly with soap and water.

### 10.6 OTHERS

- (1) A strong incident light into LCD panel might cause display characteristic changing inferior because of polarizer film, color filter, and other materials becoming inferior. Please do not expose LCD module direct sunlight and strong UV rays.
- (2) Please pay attention to a panel side of LCD module not to contact with other materials in preserving it alone.
- (3) For the packaging box, please pay attention to the followings:
  - Packaging box and inner case for LCD are designed to protect the LCDs from the damage or scratching during transportation. Please do not open except picking LCDs up from the box.
  - Please do not pile them up more than 3 boxes. (They are not designed so.) And please do not turn over.
  - Please handle packaging box with care not to give them sudden shock and vibrations. And also please do not throw them up.
  - Packing box and inner case for LCDs are made of cardboard. So please pay attention not to get them wet. (Such like keeping them in high humidity or wet place can occur getting them wet.)