



Chunghwa Picture Tubes, Ltd. Technical Specification

To :
Date :

TFT LCD
CLAA141WB02

ACCEPTED BY:

Handwritten signature: Hsu Sheng Yang

APPROVED BY	CHECKED BY	PREPARED BY
黃奕凱	劉益群	申珮君

Prepared by : TFT-LCD Product Planning Management Division

CHUNGHWA PICTUER TUBES, LTD.

1127 Hopin Rd., Padeh, Taoyuan, Taiwan 334, R.O.C.
TEL: +886-3-3675151 FAX: +886-3-377-3001

Doc.No: CLAA141WB02

Issue Date:

1. OVERVIEW

CLAA141WB02(with LVDS interface) is 14.1" color TFT-LCD (Thin Film Transistor Liquid Crystal Display) module composed of LCD panel , driver ICs , control circuit , and backlight.

By applying 6 bits digital data, 1280×800, 262K color images are displayed on the 14.1" diagonal screen. Input power voltage is single 3.3V for LCD driving.

Inverter for backlight is not included in this module. General specifications are summarized in the following table:

ITEM	SPECIFICATION
Display Area(mm)	303.744(H) x 189.84.(V) (14.1-inch diagonal)
Number of Pixels	1280 x 3(H) x 800(V)
Pixel Pitch(mm)	0.2373(H) x 0.2373(V)
Color Pixel Arrangement	RGB vertical stripe
Display Mode	normally white TN
Number of Colors	262144 colors
Optimum Viewing Angle	6 o'clock
Brightness(cd/m ²)	200 (5 point average),lamp current 6mA(typ)
Power consumption(W)	5.8W (typ)
Module Size(mm)	319.5x205.5x5.5(max)
Module Weight(g)	440(max)
Backlight Unit	CCFL , 1 tube
Surface Treatment	Anti-Glare type ; Hardness: 3H

[Note] : Sign "()" means tentative value.

The LCD Products listed on this document are not suitable for use of aerospace equipment, submarine cables, nuclear reactor control system and life support systems. If customers intend to use these LCD products for above application or not listed in "Standard" as follows, please contact our sales people in advance.

Standard: Computer, Office equipment, Communication equipment, Test and Measurement equipment, Machine tool, Industrial robot, Audio and Visual equipment, Other consumer products.

2. ABSOLUTE MAXIMUM RATINGS

ITEM	SYMBOL	MIN.	MAX.	UNIT	REMARK
Power Supply Voltage for LCD	VCC	-0.3	4.0	V	
LVDS input Voltage	VIN	-0.3	VCC+0.3	V	
Static Electricity *1)	VESDt	-250	250	V	*1)
	VESDc	-15	15	KV	
ICC Rush Current *2)	I _{RUSH}	--	2	A	*2)
Operation Temperature *3)	Top	0	50		*3)*4)
Storage Temperature *3)	Tstg	-20	60		*3)*4)
Starting Lamp Voltage	V _{SL}	0	1180	V	

[Note] : *1) Test Condition : IEC 1000-4-2 ,

VESDt : Contact discharge to input connector

VESDc : Contact discharge to module

*2) measure with below circuit, If Vcc rise time increase then I_{RUSH} decrease.

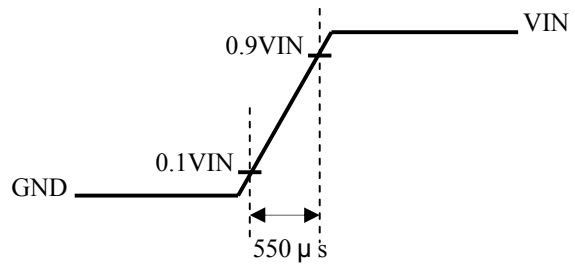
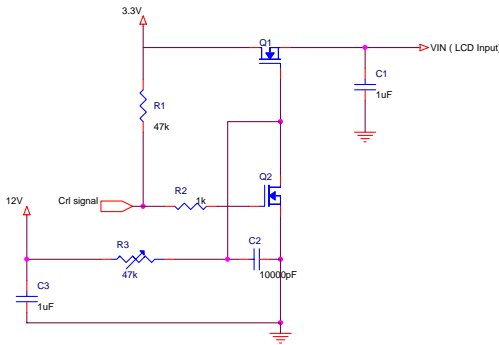

*3) Humidity 85% RH. without condensation.
90%

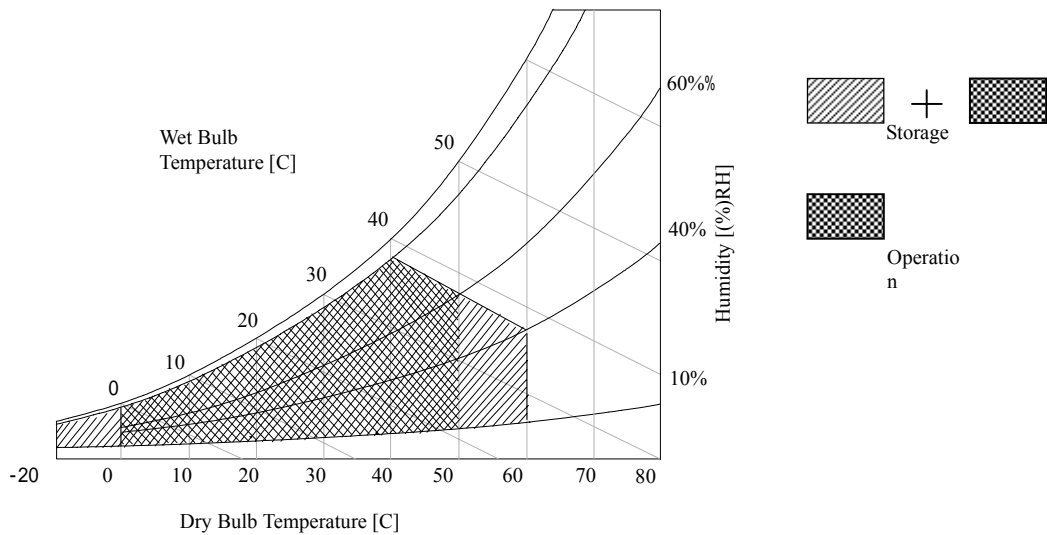

3. ELECTRICAL CHARACTERISTICS

(A) TFT LCD

Ta = 25

ITEM	SYMBOL	MIN	TYP	MAX	UNIT	Remark	
Power Supply Voltage for LCD	VCC	3.0	3.3	3.6	V		
Power Supply Current for LCD*1)	ICC	-	340	380	mA		
ICC Rush Current*2)	I _{RUSH}			1.5	A		
Logic input Voltage	Input Voltage	V _{IN}	0	-	VCC	V	
	Common Mode Voltage	V _{CM}	1.125	1.25	1.375	V	
	Differential Input Voltage	V _{ID}	250	350	450	mV	
	Threshold Voltage(High)	V _{TH}	-	-	100	mV	When VCM=+1.2V
	Threshold Voltage(Low)	V _T L	-100	-	-	mV	
Tolerance of VID	ΔVID	-	-	35	mV		
Tolerance of VCM	ΔVCM	-	-	35	mV		

[Note] : *1)Power Supply Current is in Gray0 63pattern and operation frequency is 71.1MHz(fV=60Hz).

*2)Vin rise time is 550μsec

[Note 1]

VCC=3.3V

- VCC turn on conditions :

1 < t1	10ms	500 ms	t5
0 < t2	50 ms	300 ms	t6
0 < t3	50 ms	300 ms	t7
0 < t4	10 ms		

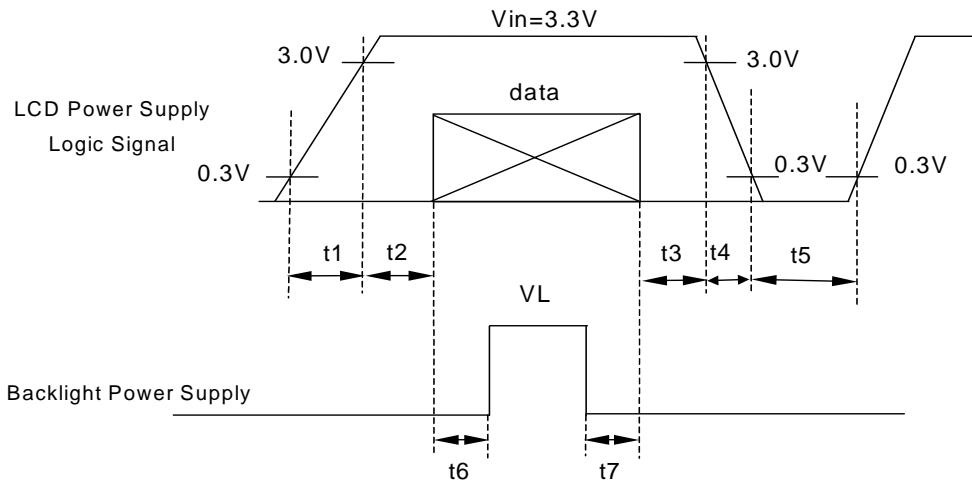

Data: RGB DATA, DCLK, HD, VD, DENA

- VCC dip conditions :

- When 2.7V VCC<3.0V, td 10 ms
- When VCC<2.7V

VCC dip conditions should follow VCC turn on conditions.

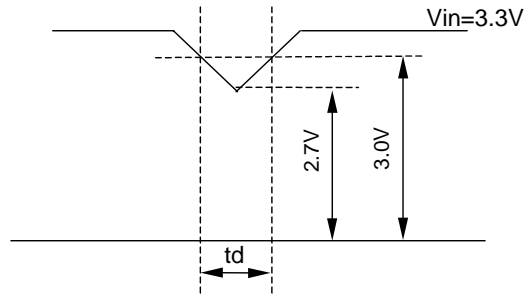

[Note 2]

- Typical value is measured when displaying horizontal gray scale line pattern
 0~63 gray level
 800 line mode
 VCC = +3.3V
 fCLKin=71.1MHz (fV=60Hz)

[Note 3]

- LVDS Signal definition :

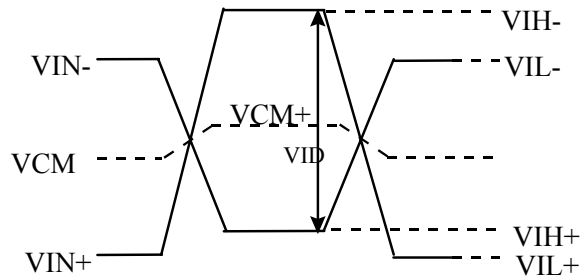
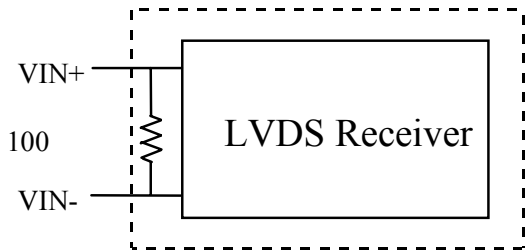

$$\begin{aligned}
 VID &= VIN_+ - VIN_- \\
 VCM &= |VCM_+ - VCM_-| \\
 VID &= |VID_+ - VID_-| \\
 VID_+ &= |VIH_+ - VIH_-| \\
 VID_- &= |VIL_+ - VIL_-| \\
 VCM &= (VIN_+ - VIN_-) / 2 \\
 VCM_+ &= (VIH_+ - VIH_-) / 2 \\
 VCM_- &= (VIL_+ - VIL_-) / 2
 \end{aligned}$$

VIN₊ = Positive differential DATA & CLK Input
 VIN₋ = Negative differential DATA & CLK Input

(B) BACK LIGHT STSTEM

Ta=25

ITEM	SYMBOL	MIN	TYP	MAX	UNIT
Lamp Voltage	VL	-	650	-	V
Lamp Current *1)	IL	3.0	6.0	6.5	mA
Inverter Frequency*3)	FI	50	-	60	KHz
Lamp life time *2)	Life L	15,000	-	-	hr
Starting Lamp Voltage	Ta = 0 *4)	Vs	-	1420	V
	Ta = 25		-	1180	

[Note 1]

- *1) Lamp Current measurement method (The current meter is inserted in cold line)
 Standard inverter : SUMIDA IV11145T/AB2-LF , typical luminance = 200 cd/m² (5 point).
 The time that module luminance reduced to 50% of initial value .
 Base on Vs = (1180) V , Ta = 25°C, IL=6.0 mA continuous.

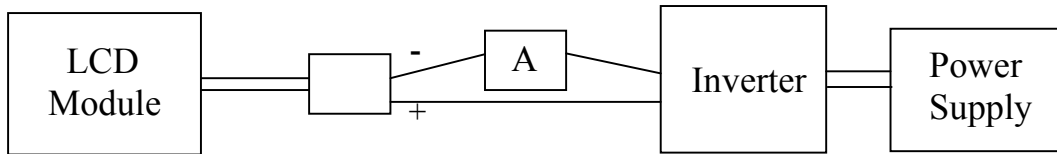

[Note 2]

Lamp frequency of inverter may produce interference with horizontal synchronous frequency, and this may cause horizontal beat on the display. Therefore, please adjust lamp frequency, and keep inverter as far from module as possible or use electronic shielding between inverter and module to avoid the interference.

The degrees of unbalance: less than 10%
 The ratio of wave height: less than $\sqrt{2} \pm 10\%$

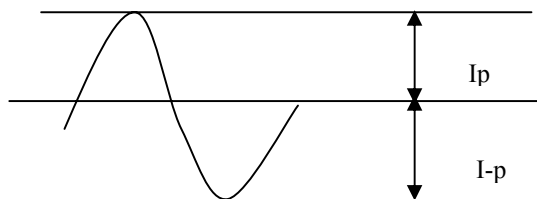

The degrees of umbalance = $\frac{|Ip-I-p|}{I_{rms}} * 100(\%)$

The ratio of wave height = $\frac{Ip(or I-p)}{I_{rms}}$

Ip: lamp current high side peak, I-p: lamp current low side peak

4. INTERFACE CONNECTION

(a) CN1(Interface signal)

* Connector type : FI-XB30SL-HF10 (JAE)

FI-X30HL (JAE,ROW Type)、FI-X30C2EL(JAE,COAXIAL Type)

pin	Symbol	Function
1	VSS	Ground
2	VCC	+3.3V
3	VCC	+3.3V
4	V_EDID	DDC 3.3V Power
5	BIST	Panel BIST test
6	CLK_EDID	DDC Clock
7	DATA_EDID	DDC Data
8	R0M	LVDS Receiver Signal(-)—channel 0
9	R0P	LVDS Receiver Signal(+)—channel 0
10	Ground	Ground
11	R1M	LVDS Receiver Signal(-)—channel 1
12	R1P	LVDS Receiver Signal(+)—channel 1
13	Ground	Ground
14	R2M	LVDS Receiver Signal(-)—channel 2
15	R2P	LVDS Receiver Signal(+)—channel 2
16	Ground	Ground
17	RCLKM	LVDS Clock Signal(-)
18	RCLKP	LVDS Clock Signal(+)
19	Ground	Ground
20	NC	No Connect (Open)
21	NC	VCOM test provided , but customer-end unused ; No Connect (open)
22	NC	No Connect (Open)
23	NC	No Connect (Open)
24	NC	No Connect (Open)
25	NC	No Connect (Open)
26	NC	No Connect (Open)
27	NC	No Connect (Open)
28	NC	No Connect (Open)
29	NC	No Connect (Open)
30	NC	No Connect (Open)

Note : pin5 BIST Function : 0(low) mean Normal Operation , 1(high) mean BIST Mode Enable

(b) CN2 (BACKLIGHT)

- Backlight-side connector: BHSR-02VS-1 (JST)
- Inverter-side connector: SM02B-BHSS-1(JST)

Pin No.	Symbol	Function
1	CTH	VBLH (High voltage)
2	CTL	VBLL (Low voltage)

[Note] VBLH-VBLL = VL

5. Input Signal Timing

(a). LVDS (Rx) Input Signal Timing Chart

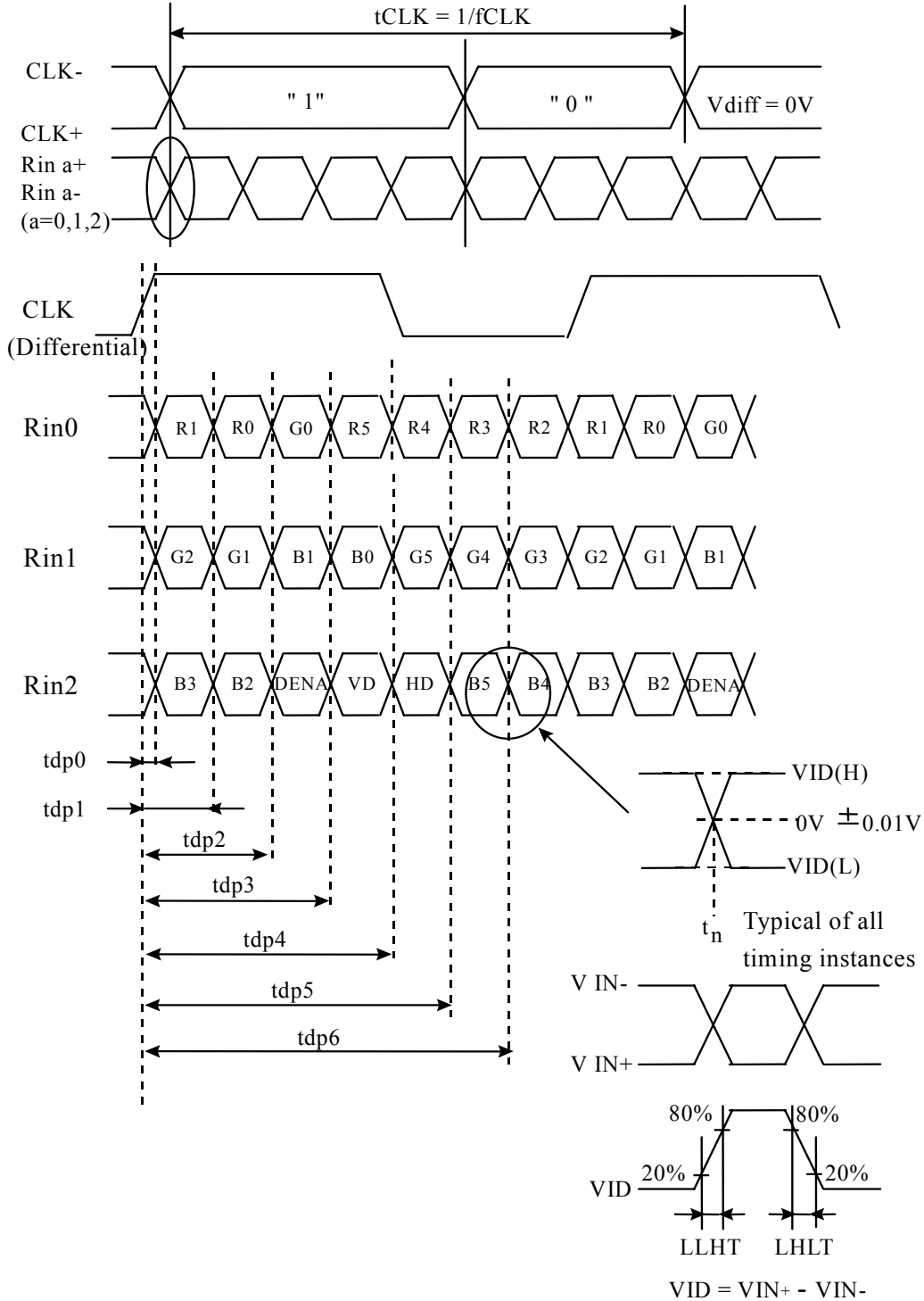

(b) LCD (Tx) Input Signal Timing Chart: (Rx output)

● Horizontal Timing:

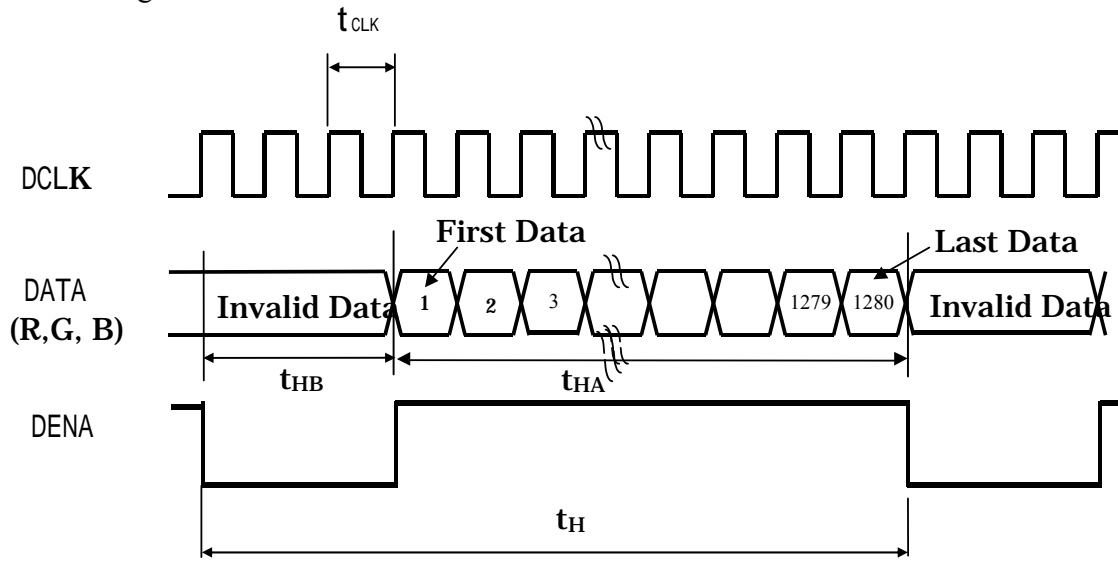

● Vertical Timing

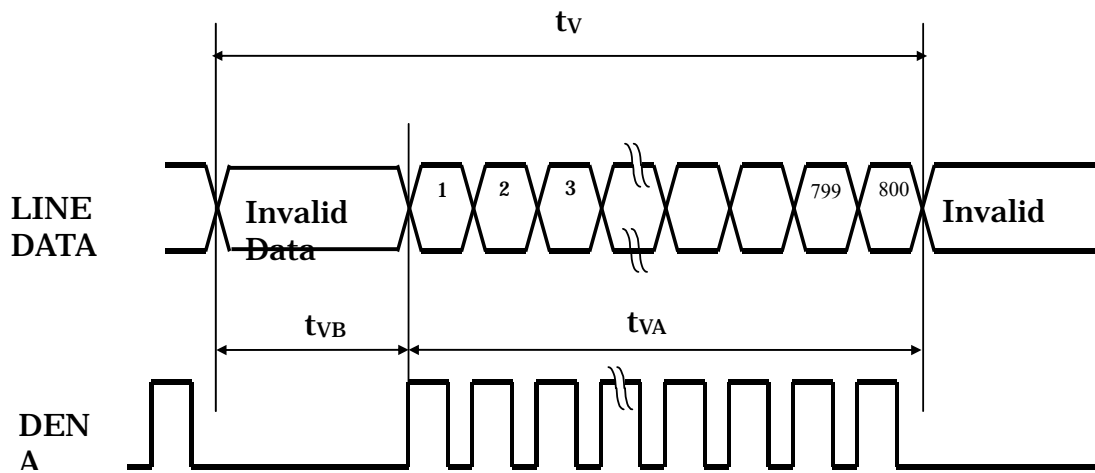

(c) Timing Specifications

VCC=3.3V , Ta=25

ITEM			SYMBOL	MIN	TYP	MAX	UNIT	
LVDS Input Timing	CLK frequency		fCLKin	62.83	71.11	80.42	MHz	
	CLK period		tCLKin	12.43	14.06	15.92	ns	
	LVDS High to Low transition time		tLVT	—	0.75	1.5	ns	
	LVDS Low to High transition time		tLVT	—	0.75	1.5	ns	
	Strobe position of Bit 0		tdp0	-0.4	0	0.4	ns	
	Strobe position of Bit 1		tdp1	T/7-0.4	T/7	T/7+0.4	ns	
	Strobe position of Bit 2		tdp2	2T/7-0.4	2T/7	2T/7+0.4	ns	
	Strobe position of Bit 3		tdp3	3T/7-0.4	3T/7	3T/7+0.4	ns	
	Strobe position of Bit 4		tdp4	4T/7-0.4	4T/7	4T/7+0.4	ns	
	Strobe position of Bit 5		tdp5	5T/7-0.4	5T/7	5T/7+0.4	ns	
	Strobe position of Bit 6		tdp6	6T/7-0.4	6T/7	6T/7+0.4	ns	
LCD input signal (LVDS Tx Input , Rx output)	DENA	Horizontal	Total	t _H	1400	1440	1480	tCLK
			Active	t _{HA}	1280	1280	1280	tCLK
			Blank	t _{HB}	120	160	200	tCLK
		Vertical	Frame Rate	f _V	55	60	65	Hz
			Tatol	t _V	816	823	836	t _H
			Active	t _{VA}	800	800	800	t _H
	Blank		t _{VB}	16	23	36	t _H	

[Note]

- 1) Data is latched at fall edge of DCLK in this specification.
- 2) DENA (Data Enable) should always be positive polarity as shown in the timing specification.
- 3) CLKIN should appear during all invalid period.
- 4) T(period) = 1/f

(d) Color data definition

Color	Input Data	R DATA						G DATA						B DATA					
		R5	R4	R3	R2	R1	R0	G5	G4	G3	G2	G1	G0	B5	B4	B3	B2	B1	B0
		MSB					LSB	MSB					LSB	MSB					LSB
Basic Color	Black	0	0	0	0	0	0	0	0	0	0	0	0	0	0	0	0	0	0
	Red(63)	1	1	1	1	1	1	0	0	0	0	0	0	0	0	0	0	0	0
	Green(63)	0	0	0	0	0	0	1	1	1	1	1	1	0	0	0	0	0	0
	Blue(63)	0	0	0	0	0	0	0	0	0	0	0	0	1	1	1	1	1	1
	Cyan	0	0	0	0	0	0	1	1	1	1	1	1	1	1	1	1	1	1
	Magenta	1	1	1	1	1	1	0	0	0	0	0	0	1	1	1	1	1	1
	Yellow	1	1	1	1	1	1	1	1	1	1	1	1	0	0	0	0	0	0
	White	1	1	1	1	1	1	1	1	1	1	1	1	1	1	1	1	1	1
RED	RED(0)	0	0	0	0	0	0	0	0	0	0	0	0	0	0	0	0	0	0
	RED(1)	0	0	0	0	0	1	0	0	0	0	0	0	0	0	0	0	0	0
	RED(2)	0	0	0	0	1	0	0	0	0	0	0	0	0	0	0	0	0	0
	RED(62)	1	1	1	1	1	0	0	0	0	0	0	0	0	0	0	0	0	0
	RED(63)	1	1	1	1	1	1	0	0	0	0	0	0	0	0	0	0	0	0
	Green	Green(0)	0	0	0	0	0	0	0	0	0	0	0	0	0	0	0	0	0
Green(1)		0	0	0	0	0	0	0	0	0	0	0	1	0	0	0	0	0	0
Green(2)		0	0	0	0	0	0	0	0	0	0	1	0	0	0	0	0	0	0
Green(62)		0	0	0	0	0	0	1	1	1	1	1	0	0	0	0	0	0	0
Green(63)		0	0	0	0	0	0	1	1	1	1	1	1	0	0	0	0	0	0
Blue		Blue(0)	0	0	0	0	0	0	0	0	0	0	0	0	0	0	0	0	0
	Blue(1)	0	0	0	0	0	0	0	0	0	0	0	0	0	0	0	0	0	1
	Blue(2)	0	0	0	0	0	0	0	0	0	0	0	0	0	0	0	0	1	0
	Blue(62)	0	0	0	0	0	0	0	0	0	0	0	0	1	1	1	1	1	0
	Blue(63)	0	0	0	0	0	0	0	0	0	0	0	0	1	1	1	1	1	1

[Note]

- (1) Definition of gray scale:
 Color(n) : n means level of gray scale .
 Bigger n means brighter level.
- (2)Data : 1= High , 0 = Low

6. BLOCK DIAGRAM

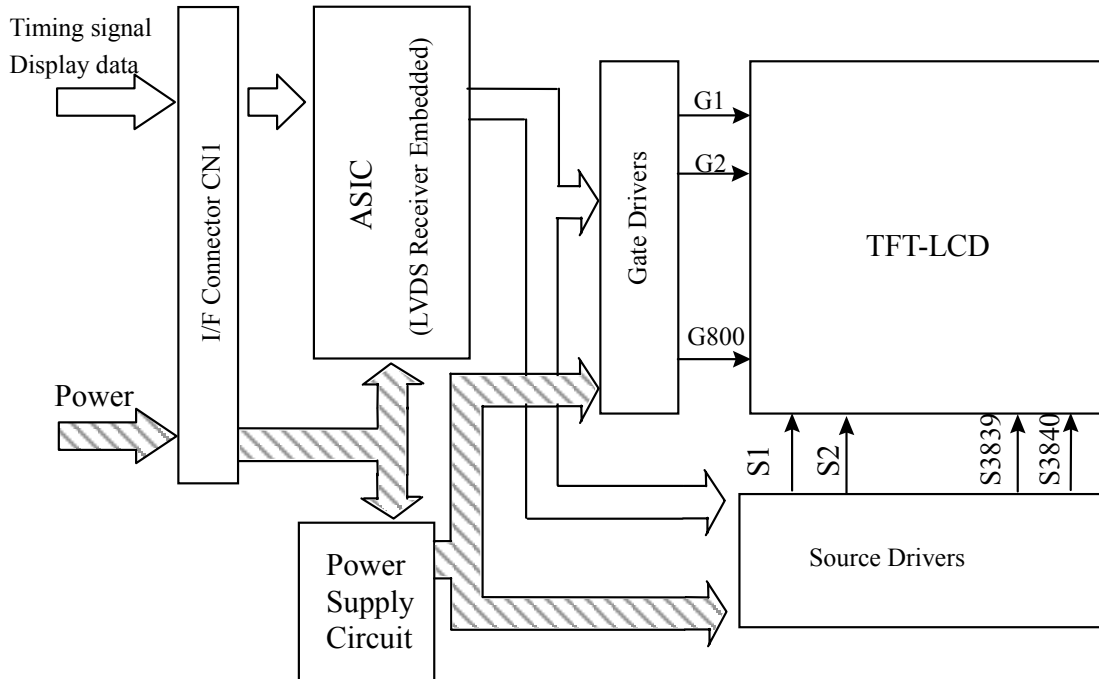

BACK LIGHT

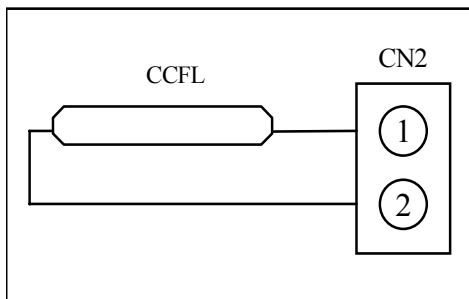

INVERTER CIRCUIT (OUT SIDE)

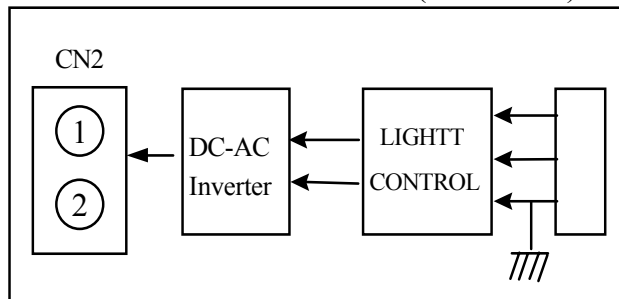

7. MECHANICAL SPECIFICATION

(1) Front side

[Unit : mm]

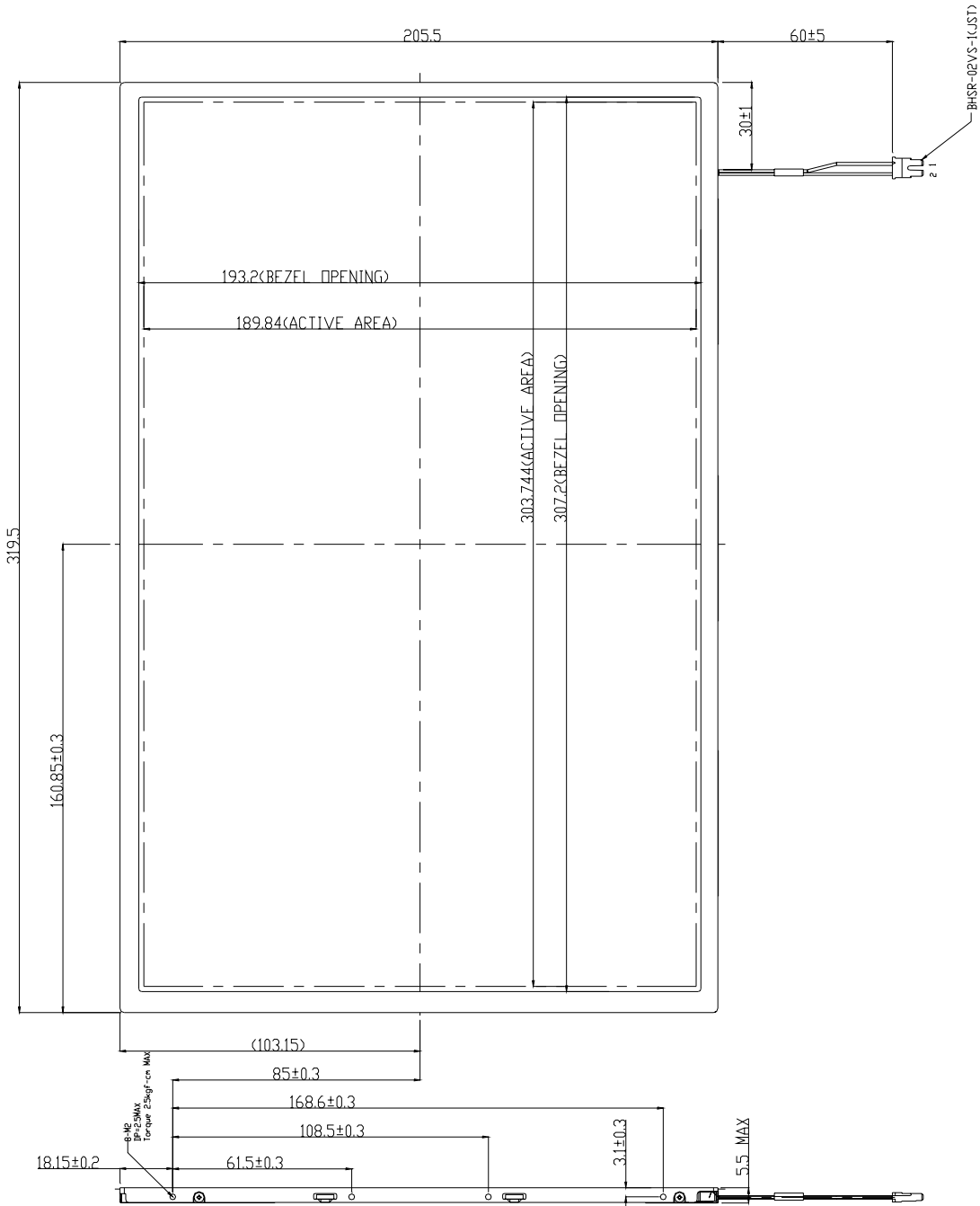

[Note] Undefined tolerances to be ±0.5 mm

(2) Rear side

[Unit : mm]

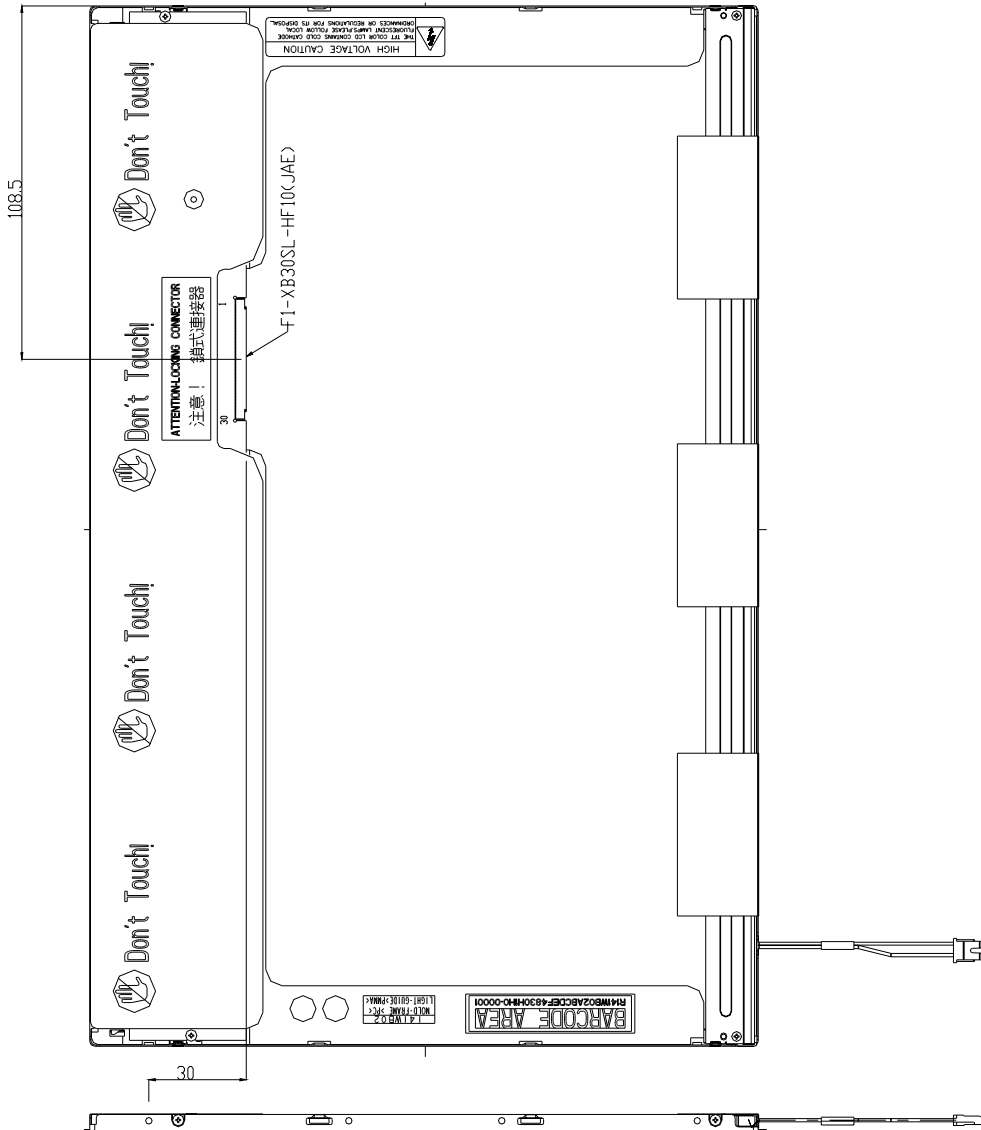

BHSR-02VS-1 (JST)

[Note] Undefined tolerances to be ± 0.5 mm

8. OPTICAL CHARACTERISTICS

Ta=25

item	symbol	condition	min	typ	max	unit	
contrast	CR	*1)	300	350	--	--	
5P Luminance	L	*3) $I_L = 6 \text{ mA}$	160	200	--	cd/m^2	
5P Luminance Uniformity	ΔL	*4)	--	--	25	%	
Response Time	Tr	*6)	--	5	20	ms	
	Tf		--	11		ms	
View angle	Horizontal	*2)CR 10	-35~35	-40 ~ 40	--	°	
	Vertical		-35~15	-40 ~ 20		°	
Crosstalk Ratio	CMR	*7)	--	--	1	%	
Image sticking	tis	*8)	--	--	2	s	
Color Temperature Coordinate	RED	x	$\theta = \phi = 0^\circ$	0.559	0.589	0.619	--
		y		0.296	0.326	0.356	
	GREEN	x		0.285	0.315	0.345	
		y		0.510	0.540	0.570	
	BLUE	x		0.123	0.153	0.183	
		y		0.095	0.125	0.155	
	WHITE	x		0.285	0.315	0.345	
		y		0.300	0.330	0.360	

[Note]

These items are measured using BM-5A(TOPCON)under the dark room condition(no ambient light) after more than 30 minutes from turning on the lamp unless noted.

Condition: $I_L=6.0 \text{ mA}$, Inverter Frequency=50kHz. Inverter : SUMIDA IV11145T/AB2-LF

Definition of these measurement items are as follows:

(1)Definition of Contrast Ratio : $CR = \text{ON(White)Luminance} / \text{OFF(Black)Luminance}$

(2)Definition of Luminance and Luminance uniformity :

Measure White Luminance on the below center(1) , 5 point(1,2,3,4,5)

5 and 13 point Uniformity : $\Delta L = [(L_{MAX} - L_{MIN}) / L_{MIN}] \times 100\%$

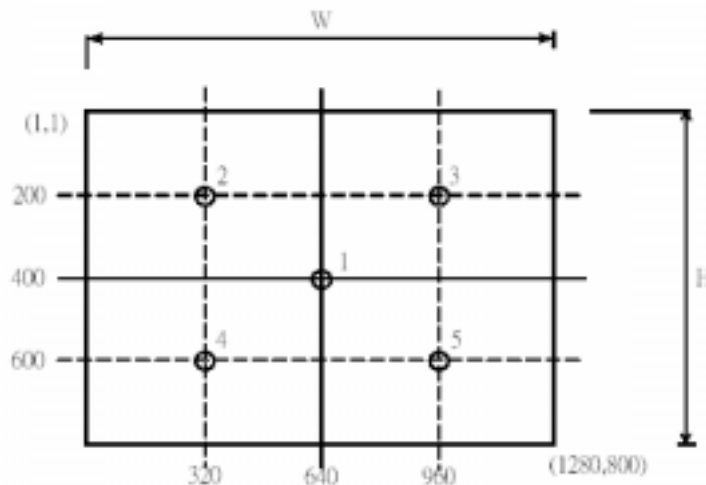

(3) Definition of Viewing Angle(θ ,)

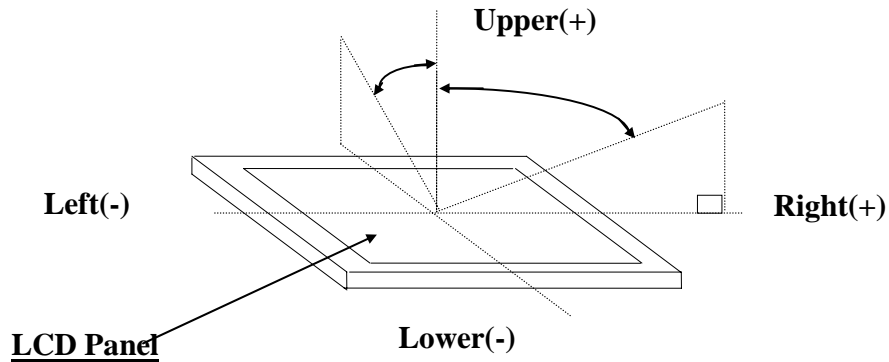

(4) Definition of Response Time

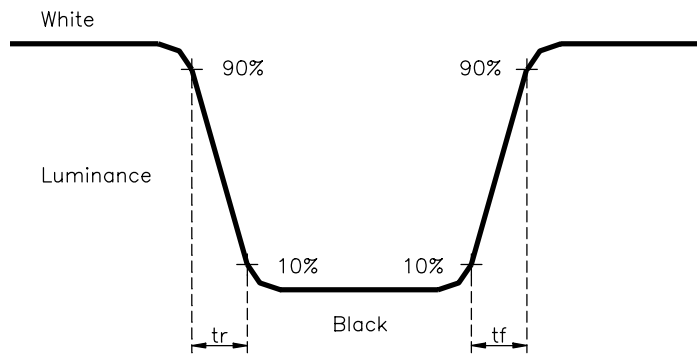

(5) Definition of Contrast Ratio Uniformity

$$CR = [CR(\text{MAX}) / CR(\text{MIN}) - 1] \times 100$$

(6) Definition of Luminance Uniformity

$$L = [L(\text{MAX}) / L(\text{MIN}) - 1] \times 100$$

(7) Definition of Cross talk Modulation Ratio

$$CTR = \text{MAX}(|(Lb1-La)/Lc| \times 100, |(Lb2-La)/Lc| \times 100)$$

La : Pattern A(Half-Tone pattern) Measure point Luminance

Lb1,Lb2 : Pattern B1、 Pattern B2 Measure point Luminance

Lc : Pattern C(white pattern) Measure point Luminance

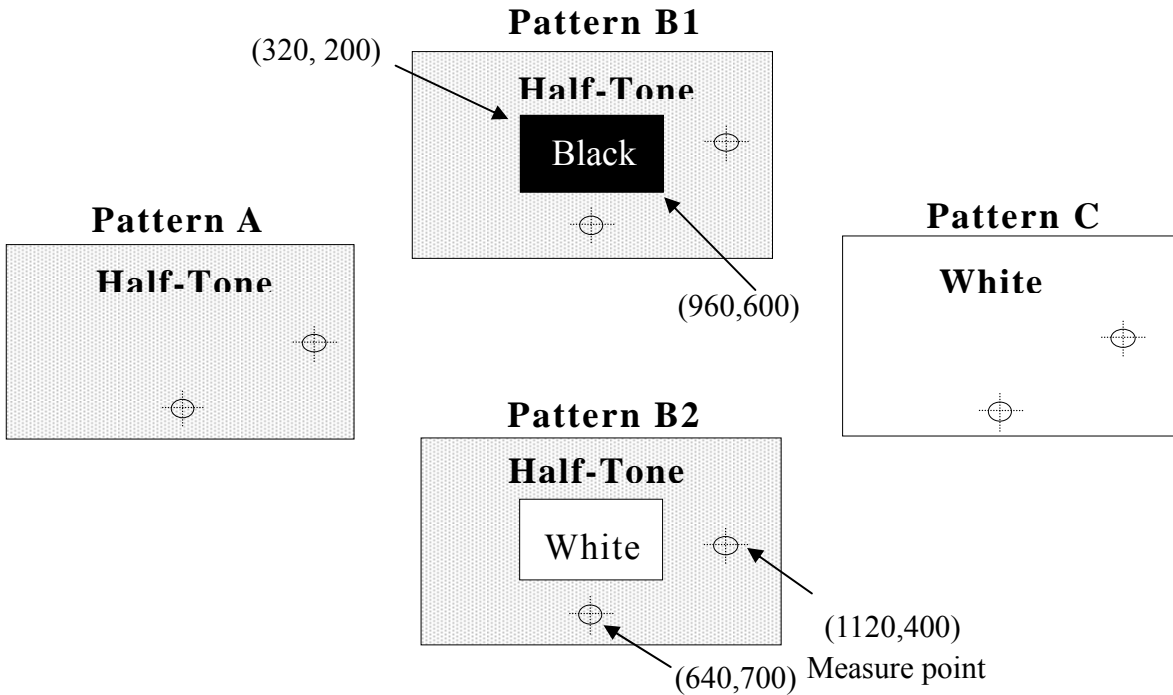

(8) Definition of Image Sticking

Continuously display the test pattern shown in the figure below for two-hours. Then display a completely white screen. The previous image shall not persist more than two seconds at 25 .

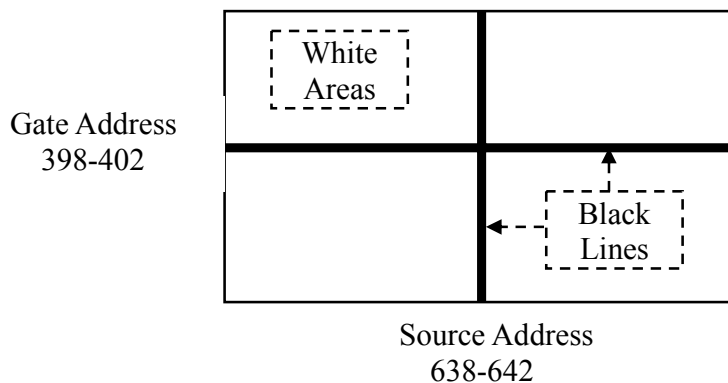

9. RELIABILITY TEST CONDITIONS

(1) Temperature and Humidity

TEST ITEMS	CONDITIONS
HIGH TEMPERATURE OPERATION	50 ,250h
HIGH TEMPERATURE STORAGE	65 ,250h
LOW TEMPERATURE OPERATION	0 ,250h
LOW TEMPERATURE STORAGE	-25 ,250h
HIGH TEMPERATURE HIGH HUMIDITY OPERATION	40° C , 95%RH ,250h
HIGH TEMPERATURE HIGH HUMIDITY STORAGE	60 , 90%RH(Max), 48h
THERMAL SHOCK(No operation)	BETWEEN -25 (0.5h)AND 65 (0.5h),100 CYCLES

(2) Shock & Vibration

ITEMS	CONDITIONS
SHOCK (NON-OPERATION)	<ul style="list-style-type: none"> ● Shock level: 1980 m/s² (200G) ● Waveform: half sinusoidal wave, 2ms ● Number of shocks: one shock input in each direction of three mutually perpendicular axes for a total of six shock inputs.
VIBRATION (NON-OPERATION)	<ul style="list-style-type: none"> ● Vibration level: 14.7 m/s² (1.5G) , sinusoidal wave, perpendicular axis(each x,y,z axis: 0.5hr , ● Frequency range: 10 to 500 Hz ● Sweep speed : 0.5 octave / min

(3) ESD test

ITEMS	CONDITIONS
ESD	<ul style="list-style-type: none"> ● Contact mode : 200pF, 0Ω, ±250V to I/F connector pins ● Air mode : 150pF, 330Ω, ±15KV to LCD glass and metal bezel

NOTE: test position(1)LCD glass and metal bezel
(2)I/F connector pins

(4)Judgment standard

The judgment of the above test should be made as follow:

Pass: Normal display image with no obvious non-uniformity and no line defect. Partial transformation of the module parts should be ignored.

Fail: No display image, obvious non-uniformity, or line defects.

10. HANDLING PRECAUTIONS FOR TFT-LCD MODULE

Please pay attention to the followings in handling- TFT-LCD products;

10.1 ASSEMBLY PRECAUTION

- (1) Please use the mounting hole on the module side in installing and do not beading or wrenching LCD in assembling. And please do not drop, bend or twist LCD module in handling.
- (2) Please design display housing in accordance with the following guidelines.
 - Housing case must be destined carefully so as not to put stresses on LCD all sides and not to wrench module. The stresses may cause non-uniformity even if there is no non-uniformity statically.
 - Keep sufficient clearance between LCD module back surface and housing when the LCD module is mounted. Approximately 1.0 mm of the clearance in the design is recommended taking into account the tolerance of LCD module thickness and mounting structure height on the housing.
 - When some parts, such as, FPC cable and ferrite plate, are installed underneath the LCD module, still sufficient clearance is required, such as 0.5mm. This clearance is, especially, to be reconsidered when the additional parts are implemented for EMI countermeasure.
 - Design the inverter location and connector position carefully so as not to give stress to lamp cable, or not to interface the LCD module by the lamp cable.
 - Keep sufficient clearance between LCD module and the others parts, such as inverter and speaker so as not to interface the LCD module. Approximately 1.0mm of the clearance in the design is recommended.
- (3) Please do not push or scratch LCD panel surface with any-thing hard. And do not soil LCD panel surface by touching with bare hands. (Polarizer film, surface of LCD panel is easy to be flawed.)
- (4) Please do not press any parts on the rear side such as source TCP, gate TCP, control circuit board and FPCs during handling LCD module. If pressing rear part is unavoidable, handle the LCD module with care not to damage them.
- (5) Please wipe out LCD panel surface with absorbent cotton or soft clothe in case of it being soiled.
- (6) Please wipe out drops of adhesives like saliva and water on LCD panel surface immediately. They might damage to cause panel surface variation and color change.
- (7) Please do not take a LCD module to pieces and reconstruct it. Resolving and reconstructing modules may cause them not to work well.
- (8) Please do not touch metal frames with bare hands and soiled gloves. A color change of the metal frames can happen during a long preservation of soiled LCD modules.
- (9) Please pay attention to handling lead wire of backlight so that it is not tugged in connecting with inverter.

10.2 OPERATING PRECAUTIONS

- (1) Please be sure to turn off the power supply before connecting and disconnecting signal input cable.
- (2) Please do not change variable resistance settings in LCD module. They are adjusted to the most suitable value. If they are changed, it might happen LCD does not satisfy the characteristics specification.
- (3) Please consider that LCD backlight takes longer time to become stable of radiation characteristics in low temperature than in room temperature.
- (4) A condensation might happen on the surface and inside of LCD module in case of sudden change of ambient temperature.
- (5) Please pay attention to displaying the same pattern for very long time. Image might stick on LCD. If then, time going on can make LCD work well.
- (6) Please obey the same caution descriptions as ones that need to pay attention to ordinary electronic parts.

10.3 PRECAUTIONS WITH ELECTROSTATICS

- (1) This LCD module use CMOS-IC on circuit board and TFT-LCD panel, and so it is easy to be affected by electrostatics. Please be careful with electrostatics by the way of your body connecting to the ground and so on.
- (2) Please remove protection film very slowly on the surface of LCD module to prevent from electrostatics occurrence.

10.4 STORAGE PRECAUTIONS

- (1) When you store LCDs for a long time, it is recommended to keep the temperature between 0 ~40 without the exposure of sunlight and to keep the humidity less than 90%RH.
- (2) Please do not leave the LCDs in the environment of high humidity and high temperature such as 60 90%RH.
- (3) Please do not leave the LCDs in the environment of low temperature; below -20 .

10.5 SAFETY PRECAUTIONS

- (1) When you waste LCDs, it is recommended to crush damaged or unnecessary LCDs into pieces and wash them off with solvents such as acetone and ethanol, which should later be burned.
- (2) If any liquid leaks out of a damaged-glass cell and comes in contact with the hands, wash off thoroughly with soap and water.

10.6 OTHERS

- (1) A strong incident light into LCD panel might cause display characteristics' changing inferior because of polarizer film, color filter, and other materials becoming inferior. Please do not expose LCD module direct sunlight and strong UV rays.
- (2) Please pay attention to a panel side of LCD module not to contact with other materials in preserving it alone.
- (3) For the packaging box, please pay attention to the followings:
 - Packaging box and inner case for LCD are designed to protect the LCDs from the damage or scratching during transportation. Please do not open except picking LCDs up from the box.
 - Please do not pile them up more than 3 boxes. (They are not designed so.) And please do not turn over.
 - Please handle packaging box with care not to give them sudden shock and vibrations. And also please do not throw them up.
 - Packing box and inner case for LCDs are made of cardboard. So please pay attention not to get them wet. (Such like keeping them in high humidity or wet place can occur getting them wet.)

11. VISUAL INSPECTION SPECIFICATION

11.1 Inspection condition:

- (1) Viewing distance is approximately 35 ~ 40 cm.
- (2) Viewing angle is normal to the LCD panel as figure below(10°).
- (3) Ambient temperature is approximately 25 ± 5 .
- (4) Ambient humidity is $60 \pm 5\%$ RH.
- (5) Ambient illumination is from 300 ~ 500 lux.
- (6) Input signal timing should be typical value.

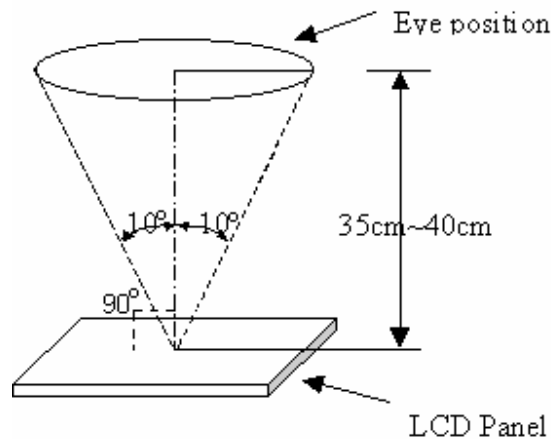

11.2 Special condition

- (1) Viewing distance is close for inspection of adjacent dots and distance between defect dots.
- (2) Viewing condition of “ Shot block non-uniformity from oblique angle” is as figure below.
- (3) Exceptional case: View angle $\pm 40^\circ$ while inspected image-sticking.

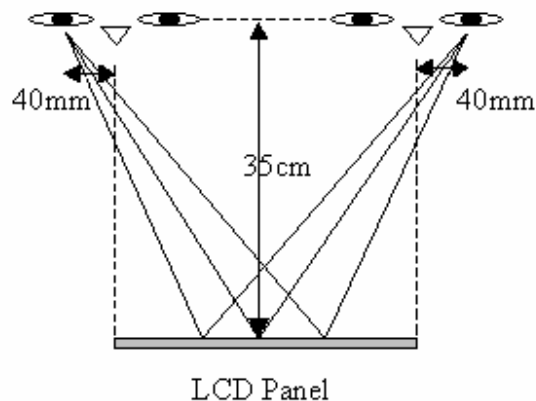

11.3 Inspection Criteria

DEFECT TYPE		LIMIT		Note	
VISUAL DEFECT	SCRATCH		0.01mm W 0.05mm L 10mm	N 4 --	
	INTERNAL	SPOT	0.15mm 0.5mm	N 4 *1)	
		FIBER	W 1.0mm, L 1.5mm	N 4 *1)	
		POLARIZER BUBBLE	0.15mm 0.5mm	N 4 *1)	
		TOTAL	N 8		--
ELECTRICAL DEFECT	BRIGHT DOT		N 4 *2)		
	DARK DOT		N 5 --		
	TOTAL DOT		N 6 *2)		
	TWO ADJACENT DOT		2 PAIRS *3)		
	THREE ADJACENT DOT		1 PAIRS		
	FOUR OR MORE ADJACENT DOT		NOT ALLOWED --		
	DISTANCE BETWEEN DEFECT DOT	Two bright dots		15mm	*4)
		Bright dot and dark dot		10mm	*4)
		Two dark dots		10mm	*4)
	LINE DEFECT		NOT ALLOWED --		
MURA		5% ND FILTER			

One pixel consists of 3 sub-pixels, including R,G, and B dot.(Sub-pixel = Dot)

[Note]

*1) W : Width[mm], L : Length[mm], N : Number, ϕ : Average Diameter

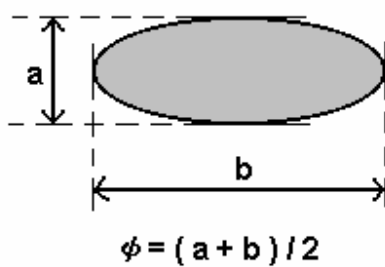

- 1. (White, black) Spot
- 2. Polarizer Bubble

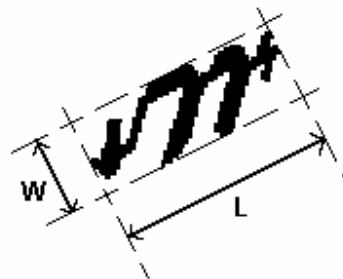

- 1. Fiber

*2) Bright dot is defined through 5% transmission ND Filter as following.

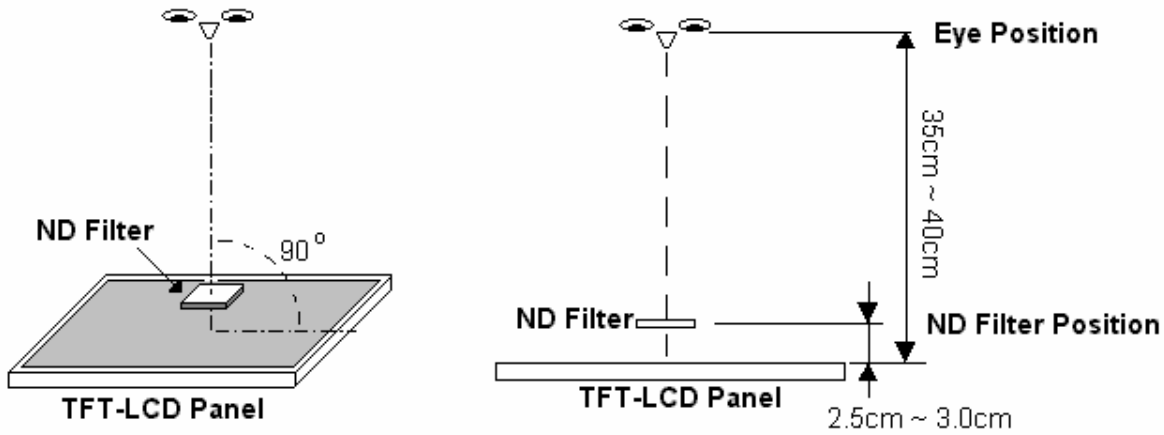

*3) Judge the defect dot and adjacent dot as following. Allow below (as A, B, C and D status) adjacent defect dots, including bright and dart adjacent dot. And they will be counted 2 defect dots in total quantity. The adjacent B status be not allow.

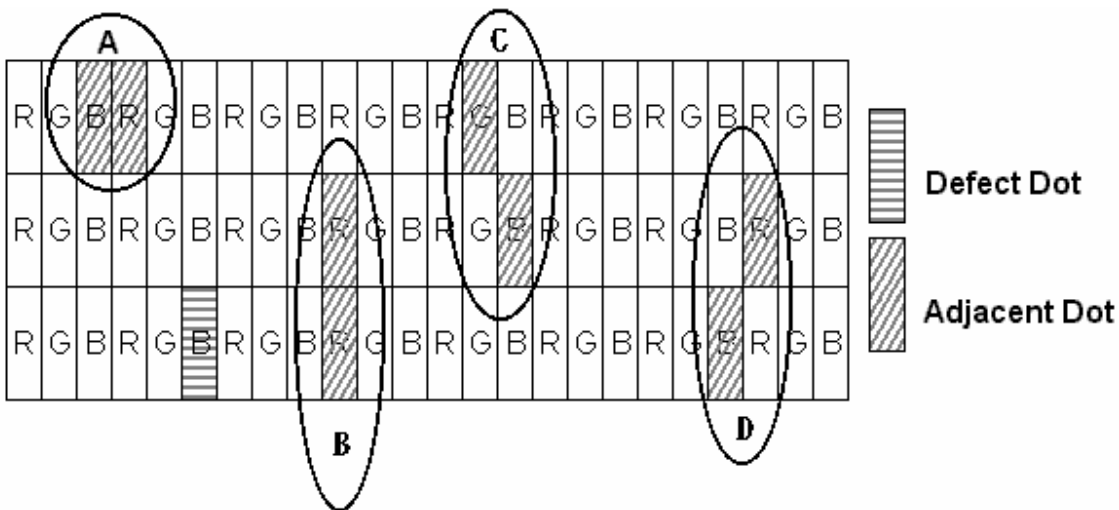

*4) Definition of distance between defect dot as following.

