



Chunghwa Picture Tubes, Ltd.

Technical Specification

To : Studio Technology Co.,Ltd

Date : 2008/09/11

CPT TFT-LCD
CLAA141WB11

ACCEPTED BY :

APPROVED BY	CHECKED BY	PREPARED BY
Ronald Huang	Roger Liu	Carol Shen

Prepared by :

Product Planning Management General Div Sales & Marketing
General Departments
CHUNGHWA PICTURE TUBES, LTD.,

1127 Hopin Rd., Padeh, Taoyuan, Taiwan 334, R.O.C.
TEL: +886-3-3675151 FAX: +886-3-377-3003

Doc.No:	CLAA141WB11-HAOSHENG-tentative1-2008/09/11	Issue Date:	2008/09/11
---------	--	-------------	------------

CONTENTS

NO.	ITEM	Page
1	OVERVIEW	2
2	ABSOLUTE MAXIMUM RATINGS	3
3	ELECTRICAL CHARACTERISTICS	4
4	CONNECTOR INTERFACE PIN & FUNCTION	7
5	INTERFACE TIMING CHART	8
6	BLOCK DIAGRAM	11
7	MECHANICAL SPECIFICATION	12
8	OPTICAL CHARACTERISTICS	14
9	RELIABILITY TEST CONDITIONS	17
10	HANDLING PRECAUTIONS FOR TFT-LCD MODULE	18
11	PACKING FORM	19
12	SAFETY	19

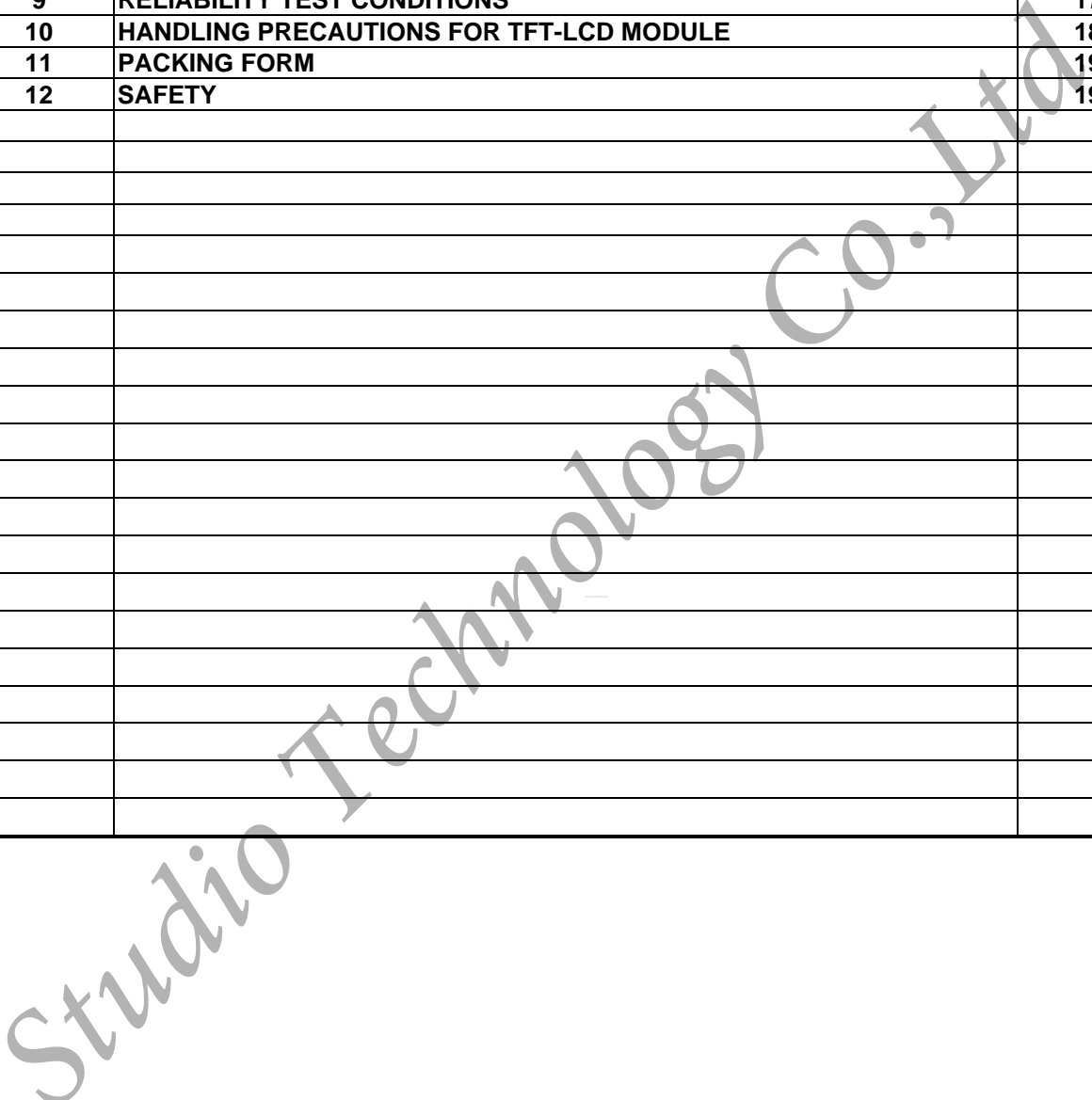

1. OVERVIEW

CLAA141WB11 is 14.1" color TFT-LCD (Thin Film Transistor Liquid Crystal Display) module composed of LCD panel, LVDS driver ICs, control circuit and backlight. By applying 6 bit digital data, 1280×RGB(3)×800, 262K-color images are displayed on the 14.1" diagonal screen. Interface of data and control signals is Typ. General specifications are summarized in the following table :

ITEM	SPECIFICATION
Display Area (mm)	303.744 (H) x 189.84 (V) (14.1-inch diagonal)
Number of Pixels	1280×3(H)×800(V)
Pixel Pitch (mm)	0.2373 (H)×0.2373 (V)
Color Pixel Arrangement	RGB vertical stripe
Display Mode	Normally white
Number of Colors	262,144(6bits)
Gamut	45% (typ)
Optimum Viewing Angle	6 o'clock
Response Time (ms)	12ms
Surface Treatment	Anti-glare ; Hardness: 3H
Viewing Angle (L/R/U/D)	40°、40° / 15°、30° (Min.)
Brightness (cd/m ²)	220 cd/m ² (5point)/20mA (Typ.) 200 cd/m ² (5point)/20mA (Min.)
Uniformity (Min)	5point : 80%
Consumption of Power (W)	4.85W (Max)
Module Size (mm)	319.5(W)×205.5(H)×5.5(D) (Max)
Module Weight (g)	440 (max)

The LCD Products listed on this document are not suitable for use of aerospace equipment, submarine cable, and nuclear reactor control system and life support systems. If customers intend to use these LCD products for applications listed above or those not included in the "Standard" list as follows, please contact our sales in advance.

Standard : Computer, Office equipment, Communication equipment, Test and Measurement equipment, Machine tool, Industrial robot, Audio and Visual equipment, other consumer products.

2. ABSOLUTE MAXIMUM RATINGS

The following are maximum value, which if exceeded, may cause faulty operation or damage to the unit.

ITEM	SYMBOL	MIN.	MAX.	UNIT	REMARK
Power Supply Voltage for LCD	VCC	-0.3	4.0	V	--
LED Forward voltage	V_F	(2.8)	(3.6)	V	--
LED Forward current	I_F	(10)	30	mA	*1). 2)
Operation Temperature	Top	(0)	(50)	°C	*3). 4). 5). 6)
Storage Temperature	Tstg	(-25)	(60)	°C	*3). 4). 5)

【Note】

- *1) Product life-time relate to LED, please operate production follow statement at page 9 “(b)back light” .
- *2) When LED current over the definition of absolute max. ,product life-time will decay rapidly or operate unusual.
- *3) The relative temperature and humidity range are as below sketch, 90%RH Max. ($T_a \leq 40^\circ\text{C}$)
- *4) The maximum wet bulb temperature $\leq 39^\circ\text{C}$ ($T_a > 40^\circ\text{C}$) and without dewing.
- *5) If product in environment which over the definition of the relative temperature and humidity out of range too long, it will affect visual of LCD.
- *6) If you operate LCD in normal temperature range, the center surface of panel should be under 60°C .

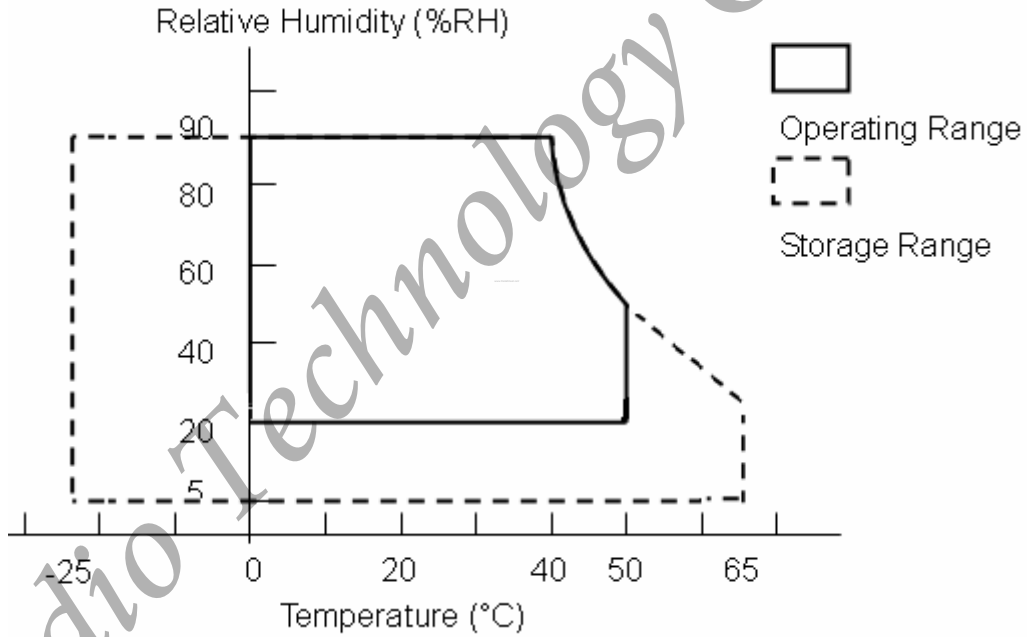

3. ELECTRICAL CHARACTERISTICS

(A) TFT LCD

TEM	SYMBOL	MIN	TYP	MAX	UNIT	REMARK	
LCD POWER VOLTAGE	VCC	3.0	3.3	3.6	V	【Note 1】	
LCD POWER CURRENT	ICC	-	350	450	mA	【Note 2】	
Rush CRRENT	Irush	-	-	2	A	【Note 4】	
LOGIC INPUT VOLTAGE (LVDS: IN+,IN-)	INPUT VOLTAGE	VIN	0	-	VCC	V	【Note 3】
	COMMON VOLTAGE	VCM	1.125	1.25	1.375	V	【Note 3】
	DIFFERENTIAL INPUT VOLTAGE	VID	250	350	450	mV	【Note 3】
	THRESHOLD VOLTAGE (HIGH)	VTH	-	-	100	mV	【Note 3】
	THRESHOLD VOLTAGE (LOW)	VTL	-100	-	-	mV	When VCM = +1.2V
DIFFERENTIAL INPUT VOLTAGE TOLERANCE	Δ VID	-	-	35	mV	--	
COMMON VOLTAGE TOLERANCE	Δ VCM	-	-	35	mV	--	

【Note 1】 Power Sequence :

- 0.5 ms < t1 ≤ 10 ms
- 0.01 ms < t2 ≤ 50 ms
- 0.01 ms < t3 ≤ 50 ms
- 1 sec ≤ t4
- 200 ms ≤ t5
- 200 ms ≤ t6

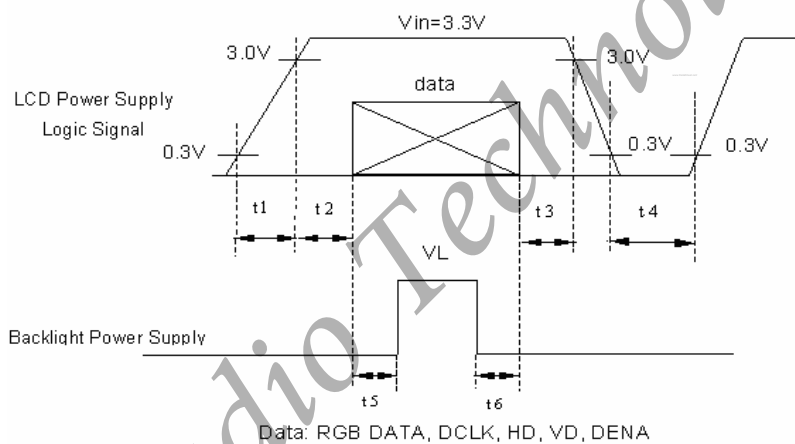

VCC-dip state

- (1) when $3.0 > VCC \geq 2.7V$, $t_d \leq 10$ ms
- (2) when $VCC < 2.7V$, VCC-dip condition should as the VCC-turn-off condition.

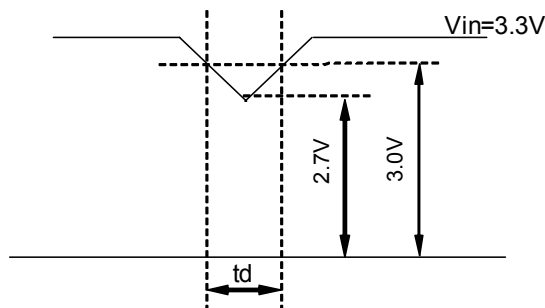

【Note 2】

Typical value is 0~63 gray level.(Horizontal line Pattern)

Circuit condition (Typ.)

VCC=3.3 V , fV=60 Hz , fH=49.38 kHz , fCLK=77.03MHz

64-Gray :
0 ~ 63 Gray

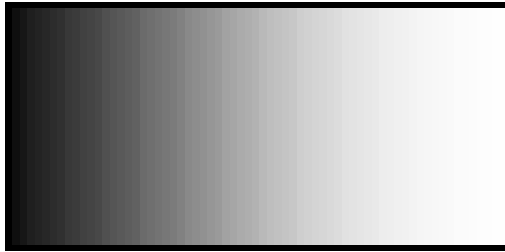

Circuit condition (MAX.)

VCC=3.3 V , fV=60 Hz , fH=49.38 kHz , fCLK=77.03MHz

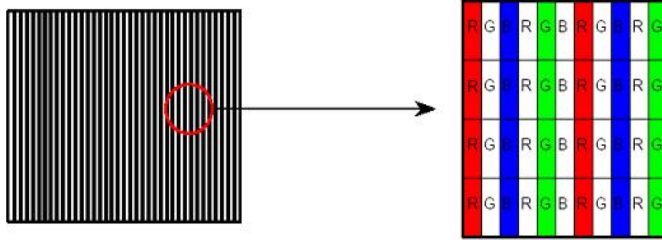

【Note 3】 LVDS Signal Definite :

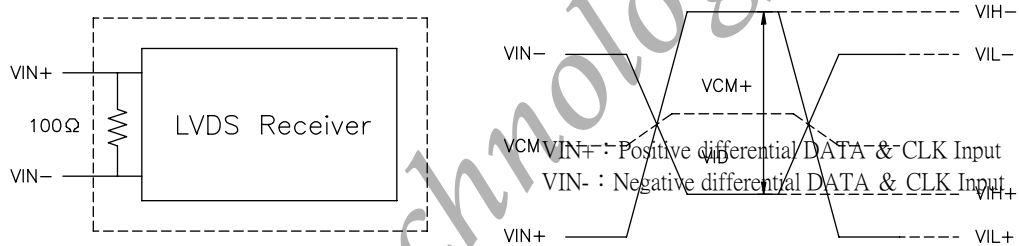

$$VID = VIN+ - VIN-$$

$$\Delta VCM = |VCM+ - VCM-| , \Delta VID = |VID+ - VID-| ,$$

$$VID+ = |VIH+ - VIH-| , VID- = |VIL+ - VIL-| ,$$

$$VCM+ = (VIN+ + VIN-)/2 , VCM- = (VIH+ + VIH-)/2 ,$$

$$VCM- = (VIL+ + VIL-)/2$$

Refer to Inverter rated voltage

【Note 4】 Irush measure condition

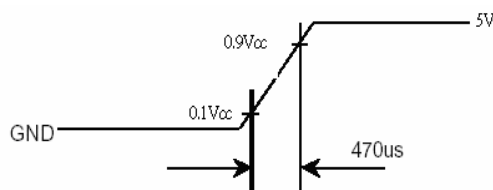
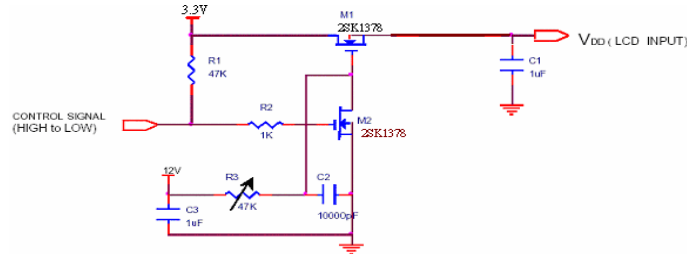

B) BACK LIGHT

(a) ELECTRICAL CHARACTERISTICS

Ta=25°C

ITEM	SYMBOL	MIN	TYP	MAX	UNIT	REMARK
Forward Voltage	V _F	(22.4)	(25.6)	(28.8)	V	I _F =20mA
Forward Current	I _F	(117)	(120)	(123)	mA	*1)
Power consumption	W	(2.69)	(3.07)	(3.46)	mW	*2)

(b)LED LIFE – TIME

ITEM	Condition	min	typ	max	UNIT	REMARK
LIFE TIME*3)	I _F =20mA、Ta=25°C	15000	-	-	hrs	--

*1) This model total LED chips for this model are 48 pcs,6(parrallel)X8(series)=48pcs chips.
1chip is 20 mA , 1 parallel is 6x20=120mA.

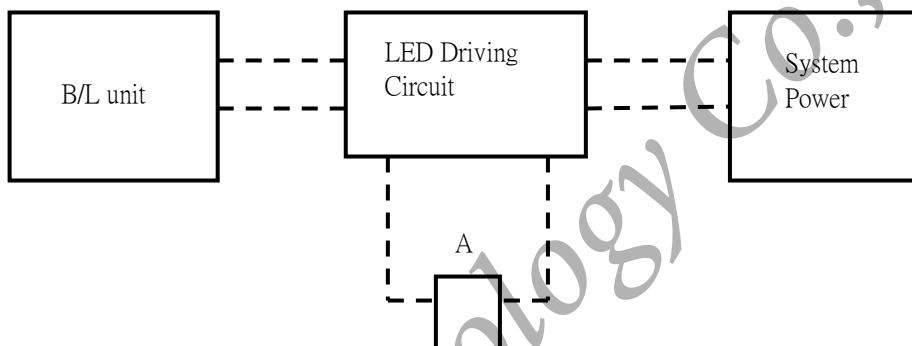

*2)This model total LED chips for this model are 48 pcs,6(parrallel)X8(series)=48pcs.
For one chip is 64mW, total BL power consumption is 48x64mW = 3.07W(typ.)

*3)Life time means that estimated time to 50% degradation of initial luminous intensity.

4. Connector Interface PIN & Function

(a) CN1 (Interface signal)

Outlet connector: FI-XB30SL-HF10-R3000 or equivalent

Pin No.	SYMBOL	Function
1	Ground	Ground
2	Vcc	+3.3V
3	Vcc	+3.3V
4	V_EDID	DDC 3.3V Power
5	NC	LCD marker test function .(No connect)
6	CLK_EDID	DDC Clock
7	DATA_EDID	DDC Data
8	R0M	LVDS Receiver Signal(-)—channel 0
9	R0P	LVDS Receiver Signal(+)—channel 0
10	Ground	Ground
11	R1M	LVDS Receiver Signal(-)—channel 1
12	R1P	LVDS Receiver Signal(+)—channel 1
13	Ground	Ground
14	R2M	LVDS Receiver Signal(-)—channel 2
15	R2P	LVDS Receiver Signal(+)—channel 2
16	Ground	Ground
17	RCLKM	LVDS Clock Signal(-)
18	RCLKP	LVDS Clock Signal(+)
19	Ground	Ground
20	NC	No connect
21	NC	VCOM test provided , but customer-end unused ; No Connect (open)
22	NC	No connect
23	NC	No connect
24	NC	No connect
25	NC	No connect
26	NC	No connect
27	NC	No connect
28	NC	No connect
29	NC	No connect
30	NC	No connect

(b) LED LIGHTBAR FPC PIN ASSIGNMENT (BACKLIGHT)

Pin No.	Symbol	Function
1	H1-	LED current sense for string 1
2	H2-	LED current sense for string 2
3	H3-	LED current sense for string 3
4	H4-	LED current sense for string 4
5	H5-	LED current sense for string 5
6	H6-	LED current sense for string 6
7	NC	Not connect
8	NC	Not connect
9	NC	Not connect
10	VCC	Input voltage power supply
11	VCC	Input voltage power supply
12	VCC	Input voltage power supply

【Note 1】

The FPC lead pad is upwards as shown in the following figure

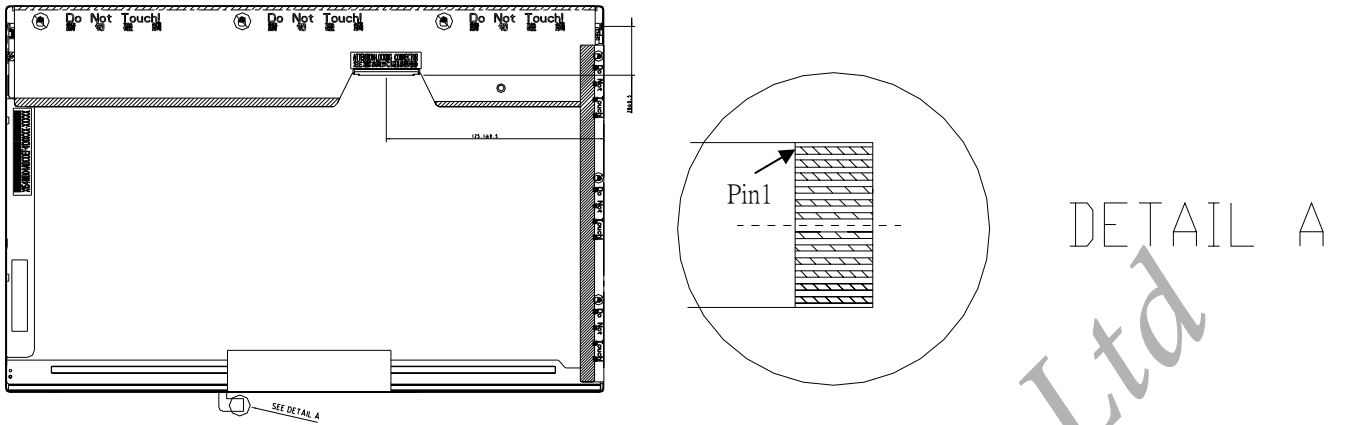

Suggested connector part no is STARCONN P/N : 089H12-000100-G2-R or equivalent.

Studio Technology Co., Ltd

5. INTERFACE TIMING CHART

(a). LVDS input time sequence

Horizontal sequence

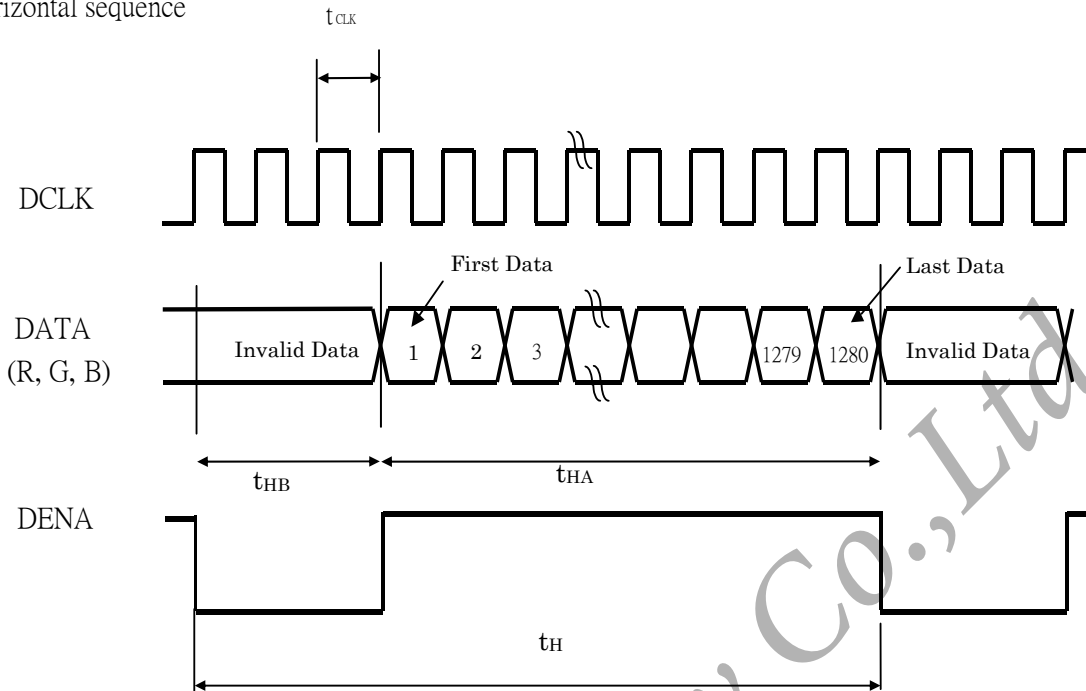

(b) LCD input time sequence

Vertical sequence

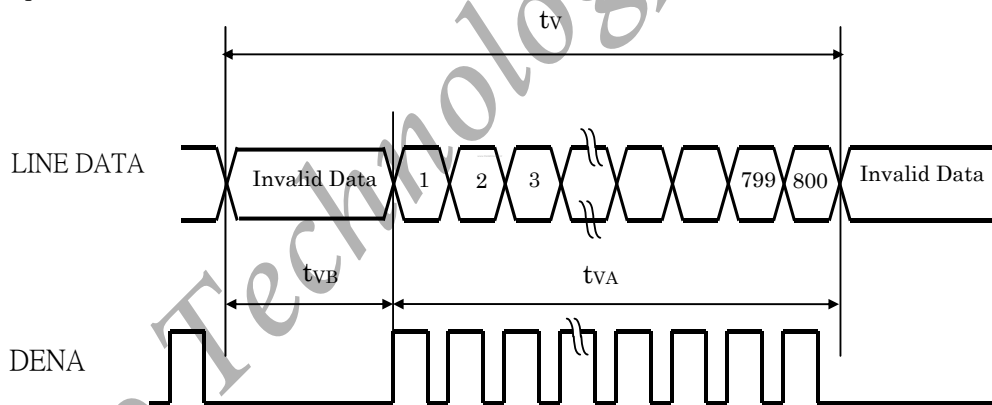

(2) Timing Chart

ITEM		SYMBOL	MIN	TYP	MAX	UNIT		
LCD Timing	Frame Rate	-	60	60	60	Hz		
	DCLK	Frequency	f_{CLK}	62.83	77.03	80.42	MHz	
		Period	t_{CLK}	12.43	12.98	15.92	ns	
	DENA	Horizontal	Horizontal total time	t_H	1400	1560	1580	t_{CLK}
			Horizontal Active time	t_{HA}	1280	1280	1280	t_{CLK}
			Horizontal Blank time	t_{HB}	120	280	300	t_{CLK}
		Vertical	Vertical total time	t_v	816	823	836	t_H
			Vertical Active time	t_{vA}	800	800	800	t_H
Vertical Blank time			t_{vB}	16	23	36	t_H	

【Note】

- *1) DENA (DATA ENABLE) usually is positive.
- *2) During the whole blank period, DCLK should keep input.

(3) DATA mapping

Color	Input Data	R DATA						G DATA						B DATA					
		R5	R4	R3	R2	R1	R0	G5	G4	G3	G2	G1	G0	B5	B4	B3	B2	B1	B0
		MS	:	:	:	:	LS	MS	:	:	:	:	LS	MS	:	:	:	:	LS
		B	:	:	:	:	B	B	:	:	:	:	B	B	:	:	:	:	B
Basic Color	Black	0	0	0	0	0	0	0	0	0	0	0	0	0	0	0	0	0	0
	Red(63)	1	1	1	1	1	1	0	0	0	0	0	0	0	0	0	0	0	0
	Green(63)	0	0	0	0	0	0	1	1	1	1	1	1	0	0	0	0	0	0
	Blue(63)	0	0	0	0	0	0	0	0	0	0	0	0	1	1	1	1	1	1
	Cyan	0	0	0	0	0	0	1	1	1	1	1	1	1	1	1	1	1	1
	Magenta	1	1	1	1	1	1	0	0	0	0	0	0	1	1	1	1	1	1
	Yellow	1	1	1	1	1	1	1	1	1	1	1	1	0	0	0	0	0	0
	White	1	1	1	1	1	1	1	1	1	1	1	1	1	1	1	1	1	1
RED	RED(0)	0	0	0	0	0	0	0	0	0	0	0	0	0	0	0	0	0	0
	RED(1)	0	0	0	0	0	1	0	0	0	0	0	0	0	0	0	0	0	0
	RED(2)	0	0	0	0	1	0	0	0	0	0	0	0	0	0	0	0	0	0
	RED(62)	1	1	1	1	1	0	0	0	0	0	0	0	0	0	0	0	0	0
	RED(63)	1	1	1	1	1	1	0	0	0	0	0	0	0	0	0	0	0	0
	Green	Green(0)	0	0	0	0	0	0	0	0	0	0	0	0	0	0	0	0	0
Green(1)		0	0	0	0	0	0	0	0	0	0	0	1	0	0	0	0	0	0
Green(2)		0	0	0	0	0	0	0	0	0	0	1	0	0	0	0	0	0	0
Green(62)		0	0	0	0	0	0	1	1	1	1	1	0	0	0	0	0	0	0
Green(63)		0	0	0	0	0	0	1	1	1	1	1	1	0	0	0	0	0	0
Blue		Blue(0)	0	0	0	0	0	0	0	0	0	0	0	0	0	0	0	0	0
	Blue(1)	0	0	0	0	0	0	0	0	0	0	0	0	0	0	0	0	0	1
	Blue(2)	0	0	0	0	0	0	0	0	0	0	0	0	0	0	0	0	1	0
	Blue(62)	0	0	0	0	0	0	0	0	0	0	0	0	1	1	1	1	1	0
	Blue(63)	0	0	0	0	0	0	0	0	0	0	0	0	1	1	1	1	1	1

【Note】

1) Definition of gray scale:

Color(n) : n means level of gray scale . Higher n means brighter level.

2) DATA:

1: high , 0: low

6. BLOCK DIAGRAM

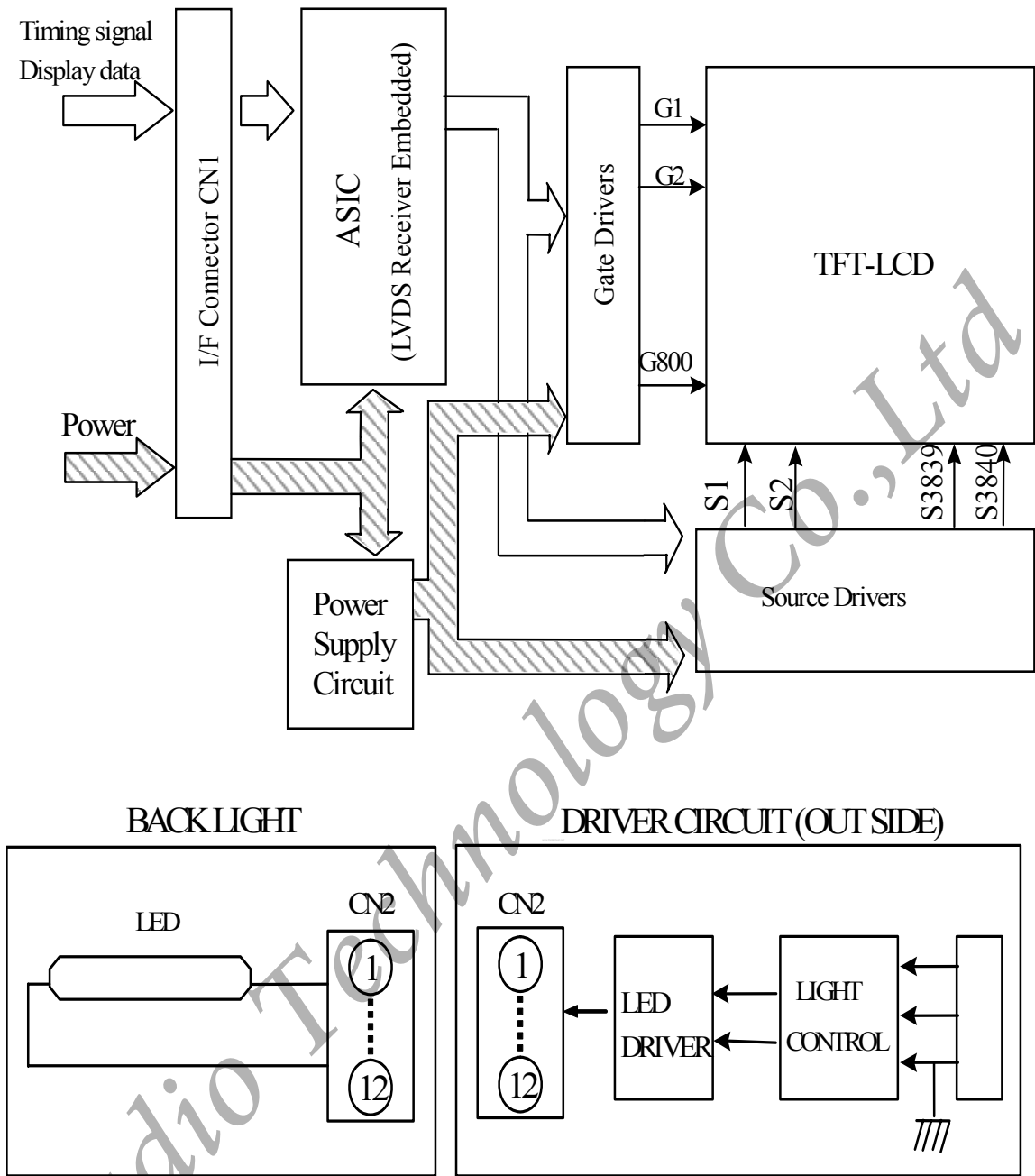

7. MECHANICAL SPECIFICATION

(1) Front side

The tolerance, not show in the figure, is $\pm 0.5\text{mm}$.

[Unit : mm]

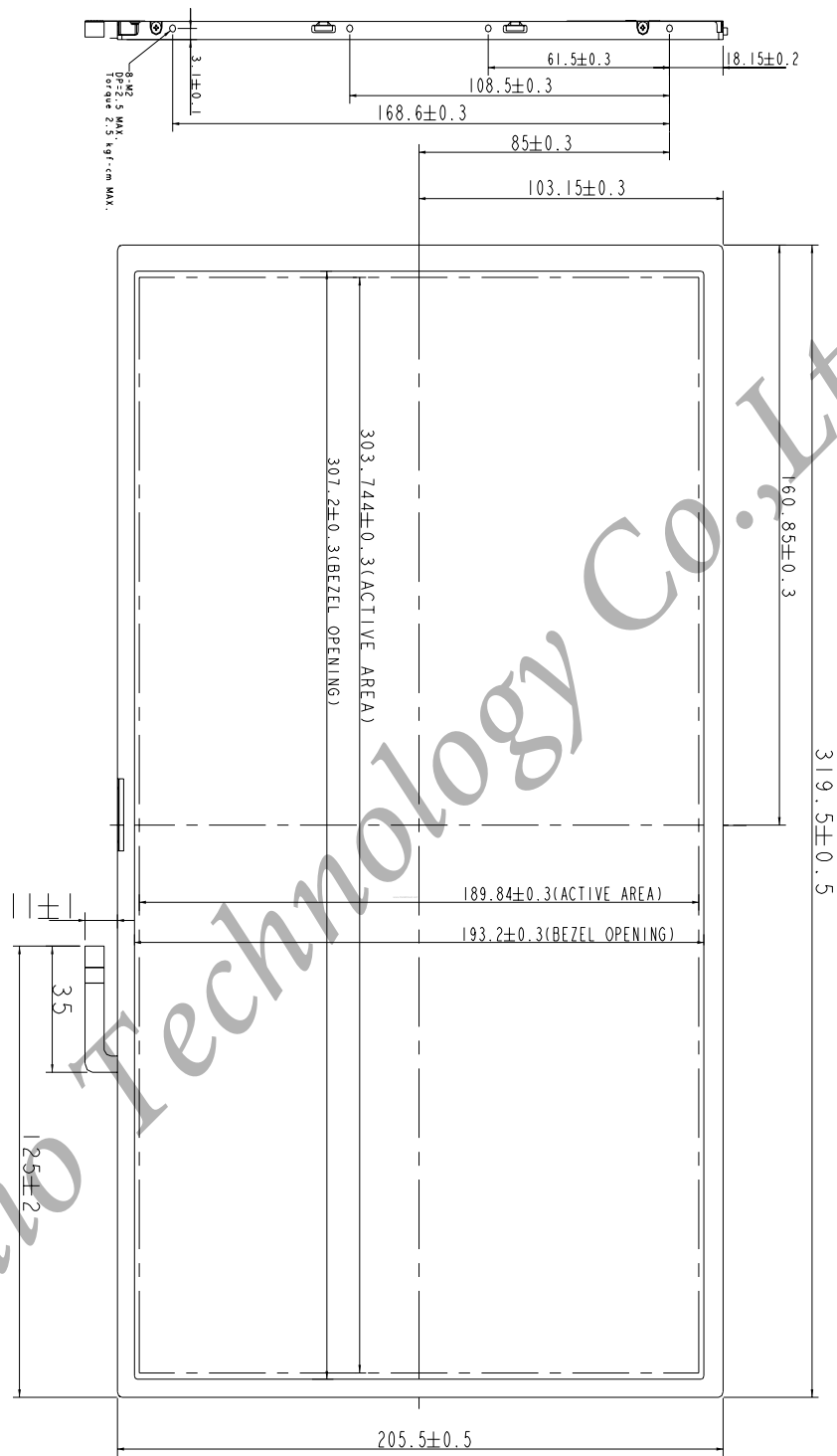

2) Rear side

The tolerance, not show in the figure, is $\pm 0.5\text{mm}$.

[Unit : mm]

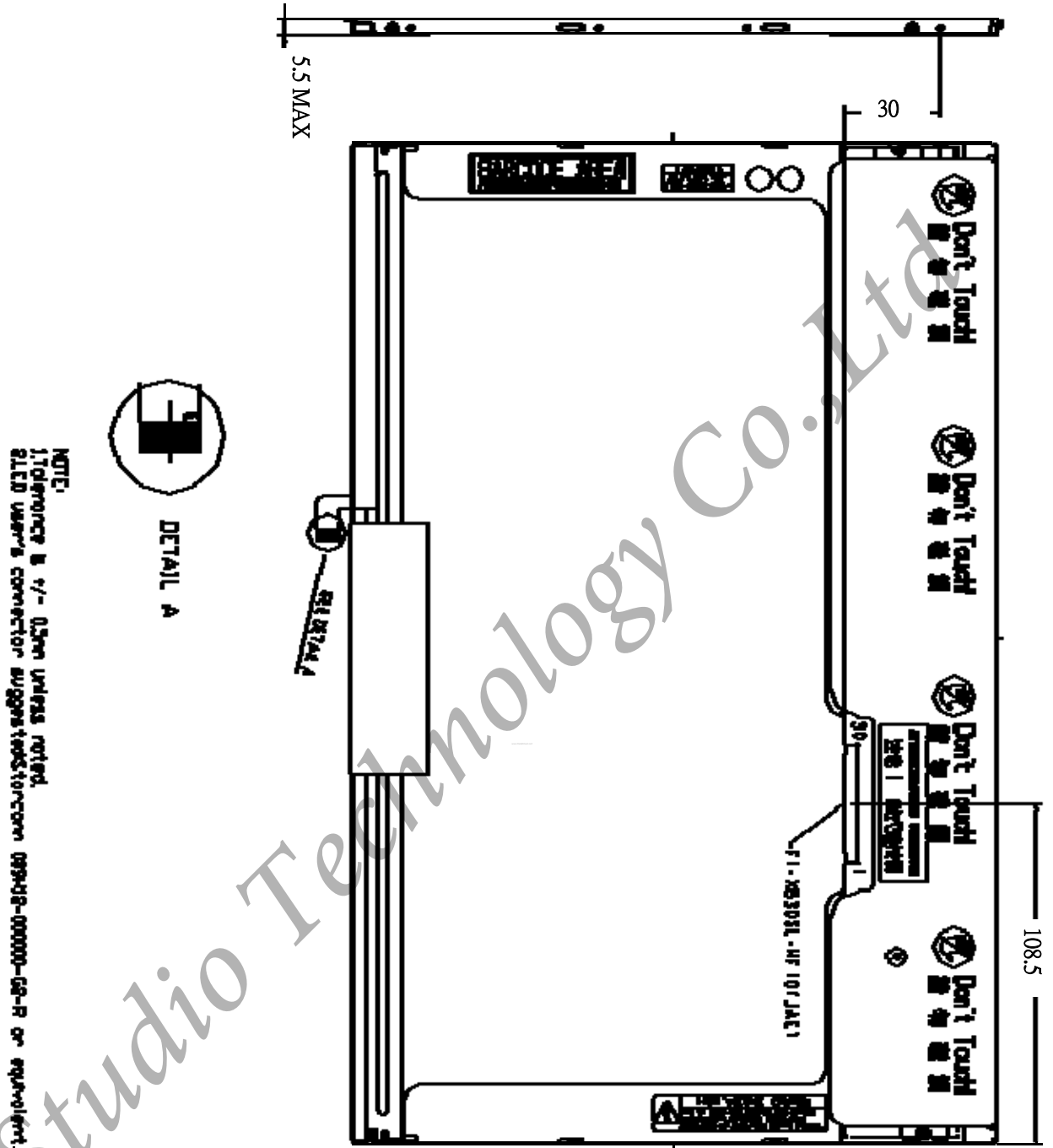

8. OPTICAL CHARACTERISTICS

Ta=25°C , VDD=3.3V

ITEM	SYMBOL	CONDITION	MIN.	TYP.	MAX.	UNIT	REMARK	
Contrast Ratio	CR	$\theta = \psi = 0^\circ$	300	400	-	--	*1) *2)	
Luminance (5P)	L	$\theta = \psi = 0^\circ$	200	220	-	cd/m ²	*1) *3)	
Uniformity(5P)	ΔL	$\theta = \psi = 0^\circ$	80	-	-	%	*1) *3)	
Response Time	Tr	$\theta = \psi = 0^\circ$	-	(4.0)	(16)	ms	*5)	
	Tf	$\theta = \psi = 0^\circ$	-	(8.0)		ms	*5)	
Image sticking	Tis	16 hours	-	-	20	min	*6)	
Cross talk	CT	$\theta = \phi = 0^\circ$ *3	-	-	1	%	*7)	
View angle	Horizontal	ψ	CR \geq 10	40/-40	-	-	°	*4)
	Vertical	θ		15/-30	-	-	°	*4)
Color Temperature Coordinate	W	X	$\theta = \psi = 0^\circ$	0.293	0.313	0.333	--	*3)
		Y		0.309	0.329	0.349		
	R	X		(0.545)	(0.565)	(0.585)	--	
		Y		(0.331)	(0.351)	(0.371)		
	G	X		(0.336)	(0.356)	(0.376)	--	
		Y		(0.537)	(0.557)	(0.577)		
B	X	(0.138)	(0.158)	(0.178)	--			
	Y	(0.115)	(0.135)	(0.155)				
Gamut		$\theta = \psi = 0^\circ$	-	(45%)	-	--	--	

【Note】

Color coordinate and color gamut are measured by SRUL1R , response time is measured by TRD-100, and all the other items are measured by BM-5A (TOPCON). All these items are measured under the dark room condition (no ambient light).

Measurement Condition: IL = 20 mA

Definition of these measurement items is as follows:

*1) Setup of Measurement Equipment

The LCD module should be turn-on to a stable luminance level to be reached. The measurement should be executed after lighting Backlight for 20 minutes and in a dark room.

*2) Definition of Contrast Ratio

CR=ON (White) Luminance/OFF (Black) Luminance

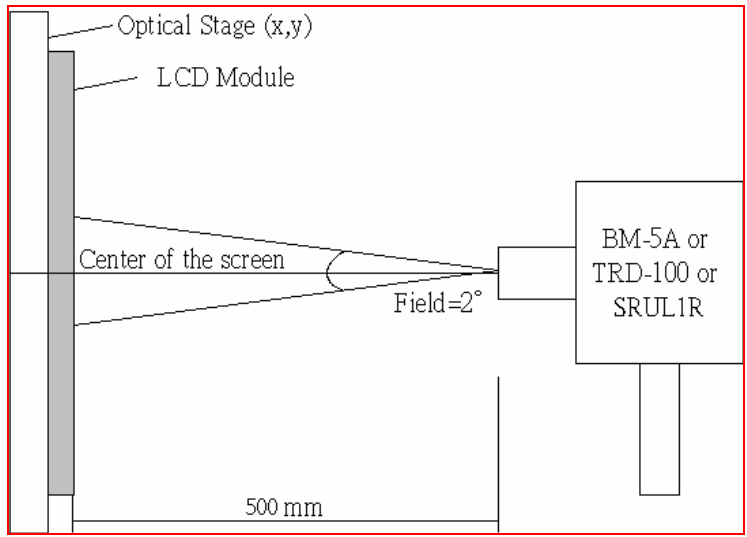

(3) Definition of Luminance and Luminance uniformity :

Definition of Average Luminance of White (L)

Measure White Luminance on the below center(5) · 5 point(5,10,11,12,13)

$$L = [L(5) + L(10) + L(11) + L(12) + L(13)] / 5$$

L(X) is corresponding to the luminance of the point X at below Figure.

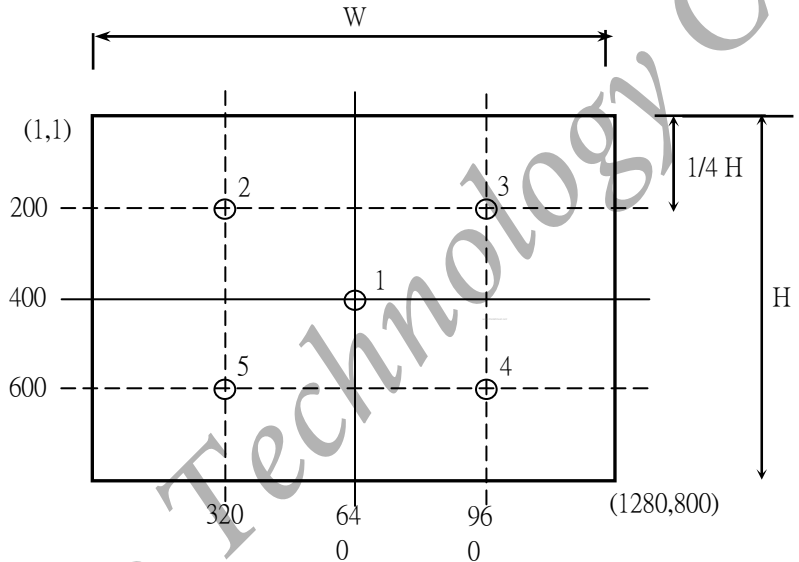

(4) Definition of Luminance Uniformity

$$\Delta L = [L(\text{MIN}) / L(\text{MAX})] \times 100$$

(5) Definition of Response Time

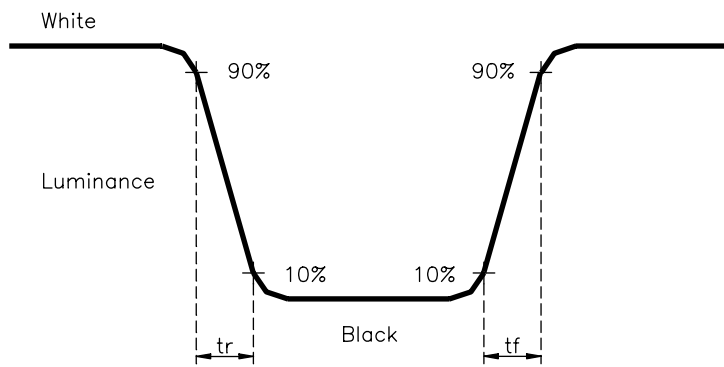

(6) Definition of Cross talk Modulation Ratio

CTR= MAX((| (Lb1-La)/Lc |)×100, (| (Lb2-La)/Lc |)×100)

La : Pattern A(Half-Tone pattern) Measure point Luminance

Lb1,Lb2 : Pattern B1、Pattern B2 Measure point Luminance

Lc : Pattern C(white pattern) Measure point Luminance

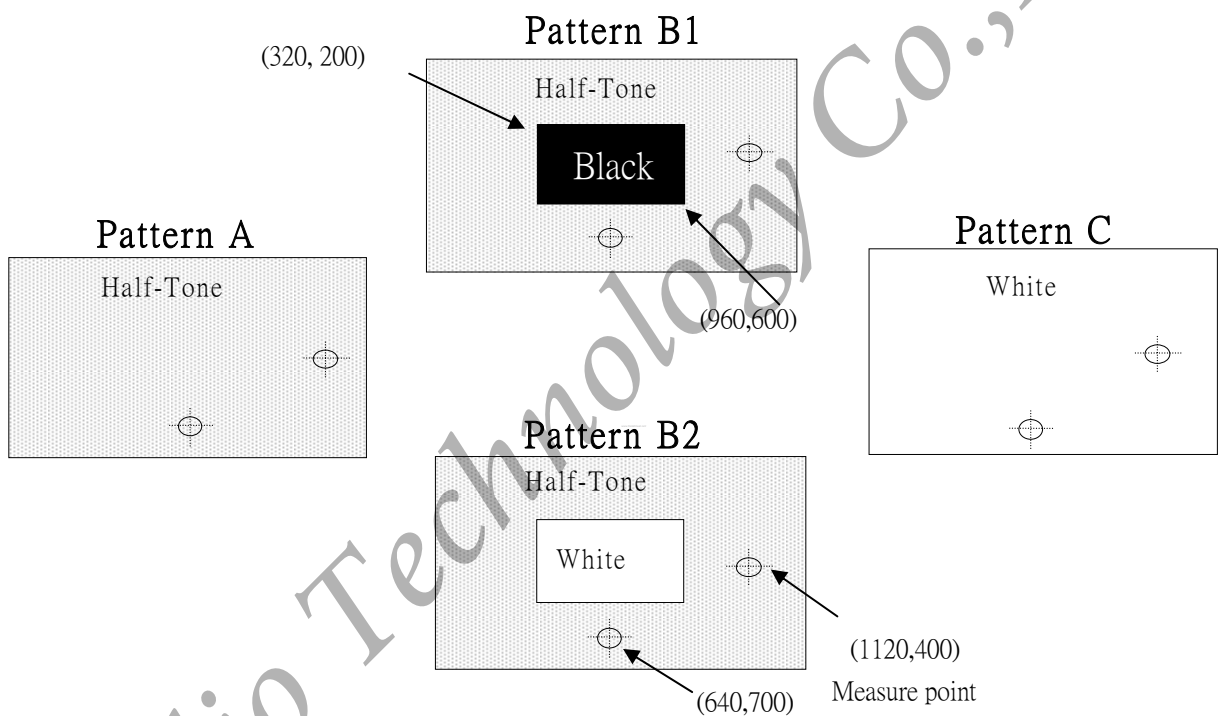

(7) Definition of Image Sticking

Continuously display the test pattern showing in the below figure for 2 hrs at 25°C.

Then switch to gray pattern, and the previous image should not persist more than 5 sec.

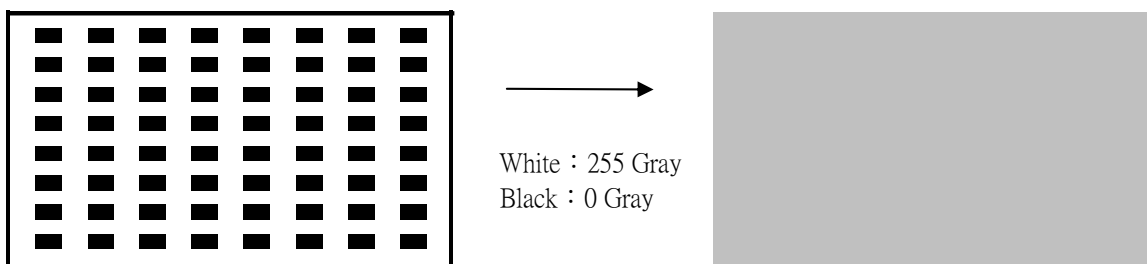

9.RELIABILITY TEST CONDITIONS

(1)Temperature and Humidity

TEST ITEMS	CONDITIONS
HIGH TEMPERATURE OPERATION	50°C,240h
HIGH TEMPERATURE STORAGE	65°C,240h
LOW TEMPERATURE OPERATION	0°C,240h
LOW TEMPERATURE STORAGE	-25°C,240h
HIGH TEMPERATURE HIGH HUMIDITY OPERATION	40° C , 95%RH ,240h
HIGH TEMPERATURE HIGH HUMIDITY STORAGE	60°C , 90%RH(Max), 48h
THERMAL SHOCK(No operation)	BETWEEN -25°C(0.5h)AND 65°C(0.5h),100 CYCLES

(2) Shock & Vibration

ITEMS	CONDITIONS
SHOCK (NON-OPERATION)	<ul style="list-style-type: none"> ● Shock level: 2156 m/s² (220G) ● Waveform: half sinusoidal wave, 2ms ● Number of shocks: one shock input in each direction of three mutually perpendicular axes for a total of six shock inputs.
VIBRATION (NON-OPERATION)	<ul style="list-style-type: none"> ● Vibration level: 14.7 m/s² (1.5G) , sinusoidal wave, perpendicular axis(each x,y,z axis: 0.5hr , ● Frequency range: 10 to 500 Hz ● Sweep speed : 0.5 octave / min

(3) ESD Test

ITEMS	CONDITIONS
ESD (OPERATION)	<ul style="list-style-type: none"> ● Air mode : ICE 1000-4-2 15KV
ESD (NON-OPERATION)	<ul style="list-style-type: none"> ● Contact mode : 200pF, 0Ω, ±250V to I/F connector pins

NOTE:test position (1)LCD glass and metal bezel
(2)I/F connector pins

(4)Judgment standard

The judgment of the above test should be made as follow:

Pass: Normal display image with no obvious non-uniformity and no line defect. Partial transformation of the module parts should be ignored.

Fail: No display image, obvious non-uniformity, or line defects.

10. HANDLING PRECAUTIONS FOR TFT-LCD MODULE

Please pay attention to the followings in handling- TFT-LCD products.

10.1 ASSEMBLY PRECAUTION

- (1) Please use the mounting hole on the module side in installing and do not beading or wrenching LCD in assembling. And please do not drop, bend or twist LCD module in handling.
- (2) Please design display housing in accordance with the following guidelines.
 - Housing case must be destined carefully so as not to put stresses on LCD all sides and not to wrench module. The stresses may cause non-uniformity even if there is no non-uniformity statically.
 - Keep sufficient clearance between LCD module back surface and housing when the LCD module is mounted. Approximately 1.0 mm of the clearance in the design is recommended taking into account the tolerance of LCD module thickness and mounting structure height on the housing.
 - When some parts, such as, FPC cable and ferrite plate, are installed underneath the LCD module, still sufficient clearance is required, such as 0.5mm. This clearance is, especially, to be reconsidered when the additional parts are implemented for EMI countermeasure.
 - Design the inverter location and connector position carefully so as not to give stress to lamp cable, or not to interface the LCD module by the lamp cable.
 - Keep sufficient clearance between LCD module and the others parts, such as inverter and speaker so as not to interface the LCD module. Approximately 1.0mm of the clearance in the design is recommended.
- (3) Please do not push or scratch LCD panel surface with any-thing hard. And do not soil LCD panel surface by touching with bare hands. (Polarizer film, surface of LCD panel is easy to be flawed.)
- (4) Please do not press any parts on the rear side such as source TCP, gate TCP, control circuit board and FPCs during handling LCD module. If pressing rear part is unavoidable, handle the LCD module with care not to damage them.
- (5) Please wipe out LCD panel surface with absorbent cotton or soft clothe in case of it being soiled.
- (6) Please wipe out drops of adhesives like saliva and water on LCD panel surface immediately. They might damage to cause panel surface variation and color change.
- (7) Please do not take a LCD module to pieces and reconstruct it. Resolving and reconstructing modules may cause them not to work well.
- (8) Please do not touch metal frames with bare hands and soiled gloves. A color change of the metal frames can happen during a long preservation of soiled LCD modules.
- (9) Please pay attention to handling lead wire of backlight so that it is not tugged in connecting with inverter.

10.2 OPERATING PRECAUTIONS

- (1) Please be sure to turn off the power supply before connecting and disconnecting signal input cable.
- (2) Please do not change variable resistance settings in LCD module. They are adjusted to the most suitable value. If they are changed, it might happen LCD does not satisfy the characteristics specification.
- (3) Please consider that LCD backlight takes longer time to become stable of radiation characteristics in low temperature than in room temperature.
- (4) A condensation might happen on the surface and inside of LCD module in case of sudden change of ambient temperature.
- (5) Please pay attention to displaying the same pattern for very long time. Image might stick on LCD. If then, time going on can make LCD work well.
- (6) Please obey the same caution descriptions as ones that need to pay attention to ordinary electronic parts.

10.3 PRECAUTIONS WITH ELECTROSTATICS

- (1) This LCD module use CMOS-IC on circuit board and TFT-LCD panel, and so it is easy to be affected by electrostatics. Please be careful with electrostatics by the way of your body connecting to the ground and so on.
- (2) Please remove protection film very slowly on the surface of LCD module to prevent from electrostatics occurrence.

10.4 STORAGE PRECAUTIONS

- (1) When you store LCDs for a long time, it is recommended to keep the temperature between 0°C ~40°C without the exposure of sunlight and to keep the humidity less than 90%RH.
- (2) Please do not leave the LCDs in the environment of high humidity and high temperature such as 60°C 90%RH.
- (3) Please do not leave the LCDs in the environment of low temperature; below -20°C.

10.5 SAFETY PRECAUTIONS

- (1) When you waste LCDs, it is recommended to crush damaged or unnecessary LCDs into pieces and wash them off with solvents such as acetone and ethanol, which should later be burned.
- (2) If any liquid leaks out of a damaged-glass cell and comes in contact with the hands, wash off thoroughly with soap and water.

10.6 OTHERS

- (1) A strong incident light into LCD panel might cause display characteristics' changing inferior because of polarizer film, color filter, and other materials becoming inferior. Please do not expose LCD module direct sunlight and strong UV rays.
- (2) Please pay attention to a panel side of LCD module not to contact with other materials in preserving it alone.
- (3) For the packaging box, please pay attention to the followings:
 - Packaging box and inner case for LCD are designed to protect the LCDs from the damage or scratching during transportation. Please do not open except picking LCDs up from the box.
 - Please do not pile them up more than 3 boxes. (They are not designed so.) And please do not turn over.
 - Please handle packaging box with care not to give them sudden shock and vibrations. And also please do not throw them up.
 - Packing box and inner case for LCDs are made of cardboard. So please pay attention not to get them wet. (Such like keeping them in high humidity or wet place can occur getting them wet.)

11. PACKING FORM

- Package quantity in one carton:
30 pcs in one carton.
- Carton size:485(L)×365(W)×365(H) (unit : mm)
- For domestic transportation only.

12. SAFETY

1. UL 60950-1, 2003, First Edition, Underwriters Laboratories. Standard Safety of Information Technology Equipment, Including Electrical Business Equipment.
2. CAN/ CSA C22.2 No. 60950-1-03 First Edition, Canadian Standards Association, April 1, 2003. Standard Safety of Information Technology Equipment, Including Electrical Business Equipment.
3. We will try our best comply the directive 2002/95/EC of the European, and that we will do our possible not to use or use exceeding the limits of banned substances. We also comply with product-related environmental laws and regulations in manufacturing process and do our best to achieve global environmental protection standards.