



Chunghwa Picture Tubes, Ltd. Technical Specification

Date : 2005/09/19

CPT TFT-LCD
CLAA150PB03_Y

ACCEPTED BY :

APPROVED BY	CHECKED BY	PREPARED BY
鍾兆其	劉益群	賴建勛

Prepared by : TFT-LCD Product Planning Management Division

CHUNGHWA PICTURE TUBES, LTD.

1127 Hopin Rd., Padeh, Taoyuan, Taiwan 334, R.O.C.
TEL: +886-3-3675151 FAX: +886-3-377-3001

Doc.No:	CLAA150PB03_Y- V1- 20050919	Issue Date:	2005/09/19
---------	-----------------------------	-------------	------------

Revision No.	Date	Page	Description
V1	2005/09/19		Final

1. OVERVIEW

CLAA150PB03_Y (with LVDS interface) is 15.0" color TFT-LCD (Thin Film Transistor Liquid Crystal Display) module composed of LCD panel , driver ICs , control circuit , and backlight. It follows SPWG spec.

By applying 6 bits digital data, 1400×1050, 262K color images are displayed on the 15.0" diagonal screen. Input power voltage is single 3.3V for LCD driving.

Inverter for backlight is not included in this module. Interface of data and control signals is Typ. 54.0MHz digital. 2 pixel data are transmitted per cycle. General specifications are summarized in the following table:

ITEM	SPECIFICATION
Display Area(mm)	304.5(H) × 228.375(V) (15.0-inch diagonal)
Number of Pixels	1400 x 3(H) x 1050(V)
Pixel Pitch(mm)	0.2175(H)×0.2175(V)
Color Pixel Arrangement	RGB vertical stripe
Display Mode	Normally white TN
Number of Colors	262144 colors
Optimum Viewing Angle	6 o'clock
Brightness(cd/m ²)	200 typ.(center,CCFL=6mA)
Power consumption(W)	Module 7.05 typ. @ 6mA (B/L 4.08W typ. @6mA)
Module Size(mm)	317.3(W) × 242.0(H) × 5.7(D) typ
Module Weight(g)	560 typ
Backlight Unit	CCFL , 1 tube
Surface Treatment	Anti-Glare(Haze value: 12%) ; Hardness: 3H

[Note] :

The LCD Products listed on this document are not suitable for use of aerospace equipment, submarine cables, nuclear reactor control system and life support systems. If customers intend to use these LCD products for above application or not listed in "Standard" as follows , please contact our sales people in advance.

Standard: Computer, Office equipment, Communication equipment, Test and Measurement equipment ,
Machine tool , Industrial robot , Audio and Visual equipment , Other consumer products.

2. ABSOLUTE MAXIMUM RATINGS

ITEM	SYMBOL	MIN.	MAX.	UNIT
Power Supply Voltage for LCD	VCC	-0.3	4.0	V
LVDS input Voltage	VIN	-0.3	VCC+0.3	V
Lamp Voltage	VL	650	880	V _{rms}
Lamp Current *1)	IL	3	6.5	mA _{rms}
Lamp Frequency	FL	50	80	kHz
Static Electricity *2)	VESDt	-250	250	V
	VESDc	-15	15	KV
ICC Rush Current *3)	I _{RUSH}		1000	mA
Operation Temperature *4)*5)*6) *7)	T _{op}	0	50	°C
Storage Temperature *4)*5)*6)	T _{stg}	-20	60	°C
Starting Lamp Voltage	V _{SL}	0	1560	V

[Note] :

*1) Lamp current has direct relation with lifetime. Please refer to backlight system. If lamp current is out of absolute maximum value, it will damage the lifetime and starting lamp quality.

*2) Test Condition: It depends on the IEC 1000-4-2 ,
 VESDt : Contact discharge to input connector
 VESDc : Contact discharge to module

*3) Control Signal: High (+3.3V) → Low (GND) , rising time of supply voltage should adjust from R3 & C2 to 470us.

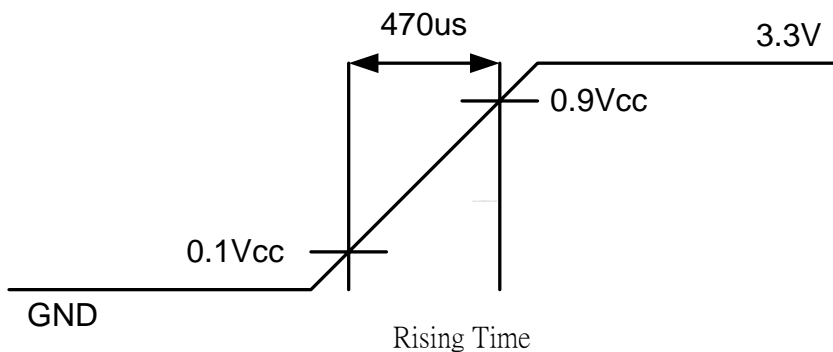
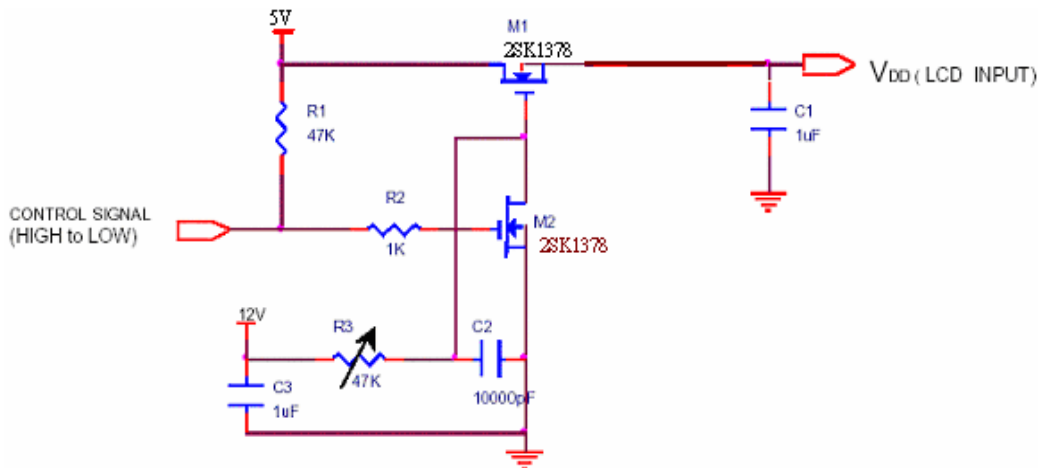

*4) Temp. vs. Humidity related chart (90% RH max., $T_a \leq 40^\circ\text{C}$):

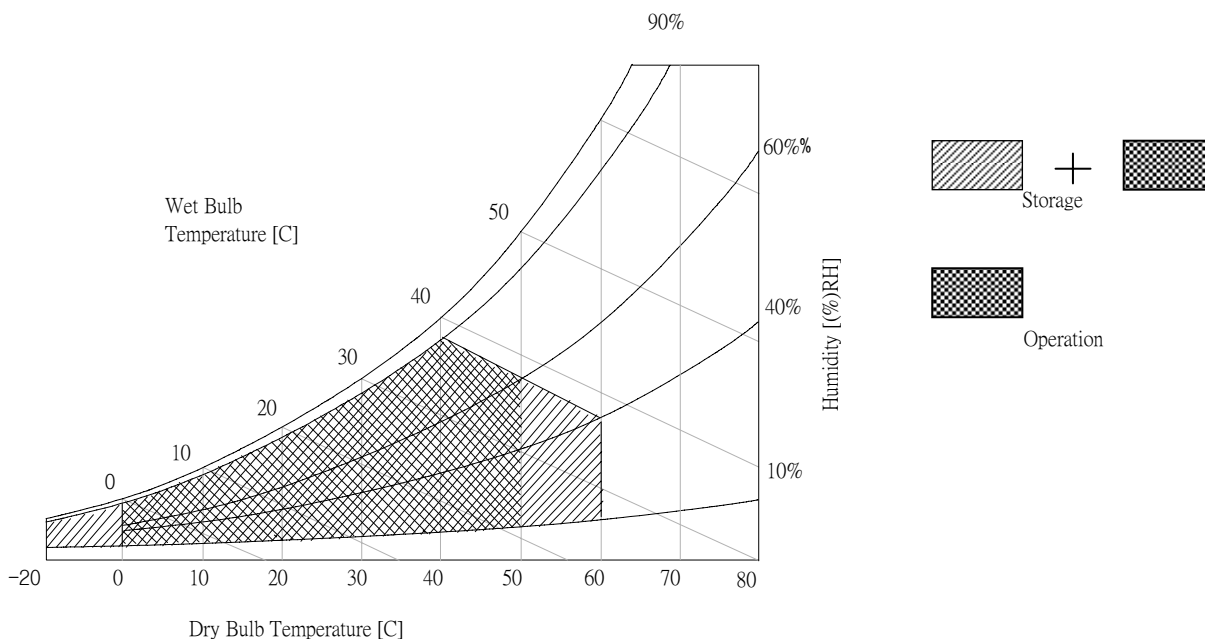

- *5) Max. Wet Bulb temp. $\leq 39^{\circ}\text{C}$ ($T_a > 40^{\circ}\text{C}$) without condensation.
- *6) If users use the product out off the environmemt operation range (temperature and humidity) , it will concern for visual quality.
- *7) The product must work at operation temperature range and the temperature of the panel's center point must lower then 60°C .

3. ELECTRICAL CHARACTERISTICS

(1)TFT-LCD

$T_a = 25^{\circ}\text{C}$

ITEM	SYMBOL	MIN	TYP	MAX	UNIT	Remark
Power Supply Voltage for LCD	VCC	3.0	3.3	3.6	V	*1)
Power Supply Current for LCD	(a) 256 Gray	--	800	1000	mA	*2)
	(b) Black	--	900	1100		
	(c) White	--	700	800		
Interface	LVDS	DSC383/385、THC63LVD823				

[Note]

*1)

- VCC turn on conditions : ($V_{CC}=3.3\text{V}$)
 - $0 < t_1 \leq 10\text{ms}$ $1 \text{ sec} \leq t_5$
 - $0 < t_2 \leq 50 \text{ ms}$ $200 \text{ ms} \leq t_6$
 - $0 < t_3 \leq 50 \text{ ms}$ $200 \text{ ms} \leq t_7$
 - $0 < t_4 \leq 10 \text{ ms}$

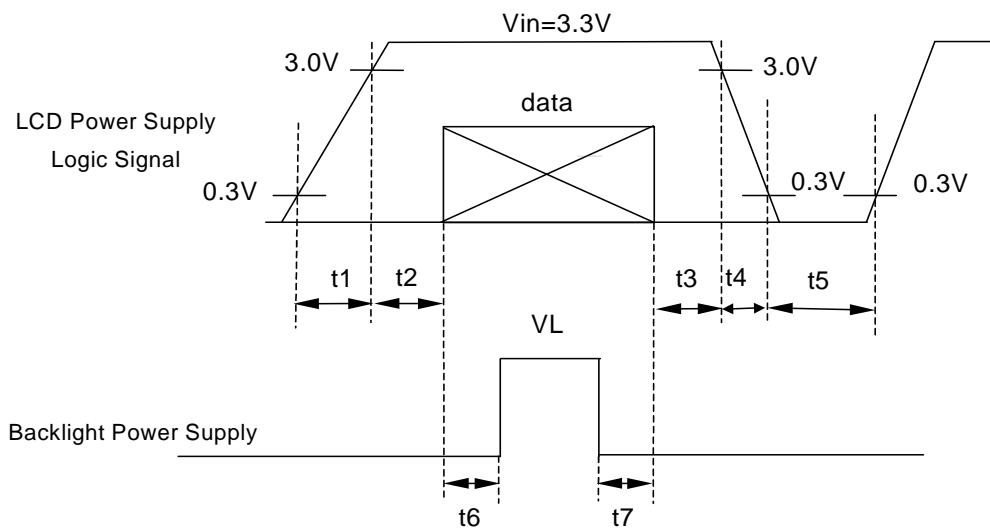

Data: RGB DATA, DCLK, HD, VD, DENA

- VCC dip conditions :
 - 1) When $2.4\text{V} \leq V_{CC} < 3.0\text{V}$, $t_d \leq 10 \text{ ms}$
 - 2) When $V_{CC} < 2.4\text{V}$, it works abnormal that must reset power.

VCC dip conditions should follow VCC turn on conditions.

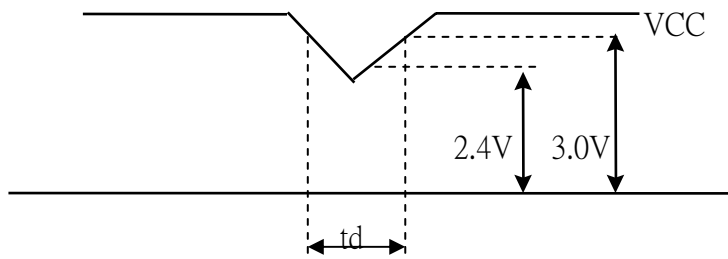

*2) Typical value is measured at 1050 line mode , VCC=3.3V

$f_H=64\text{kHz}$



(a) 256 Gray Pattern

$f_V=60\text{ Hz}$



(b) Black Pattern

$f_{CLK}=54\text{ MHz}$



(c) White Pattern

(2) Backlight system*5)

$T_a = 25^\circ\text{C}$

ITEM	SYMBOL	MIN	TYP	MAX	UNIT
Lamp Voltage	VL	612	680	748	V
Lamp Current *1)	IL	3.0	6.0	6.5	mA
Inverter Frequency *2)	FI	50	-	60	KHz
Lamp life time *3)	Life L	15000	-	-	hr
Starting Lamp Voltage *4) *5) *6)	$T_a = 0^\circ\text{C}$	-	-	1560	V
	$T_a = 25^\circ\text{C}$	-	-	1370	

[Note]

*1) Inverter : SUMIDA; type:IV11145T (61K)

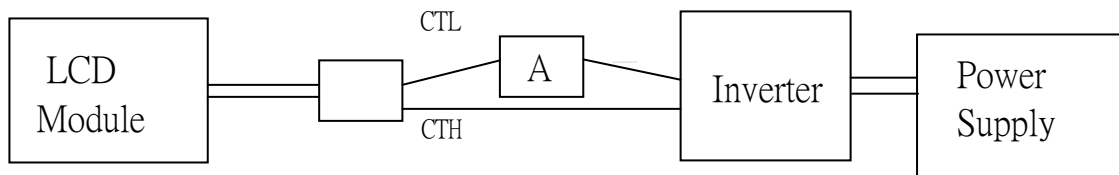

*2) 2-1. At this frequency range, electrical and optical characteristics could keep in $\pm 10\%$ range (except color coordinate).

2-2. Electrical and optical characteristics will display well at 50~60KHz frequency.

2-3. It would not damage the lifetime and reliability at 50~80KHz frequency.

*3) Definition of the lamp life time :

Luminance: Luminance (center point) reduced to 50% of initial value

*4) The lamp shall be stably lighted. Slide up method shall be used for input voltage application. The voltage is applied voltage to both ends of the lamp as the established starting voltage.

*5) Lamp frequency of inverter may produce interference with horizontal synchronous frequency, and this may cause horizontal beat on the display. Therefore, please adjust lamp frequency, and keep inverter as far from module as possible or use electronic shielding between inverter and module to avoid the interference.

The degrees of unbalance: less than 10%

The ratio of wave height: less than $\sqrt{2} \pm 10\%$

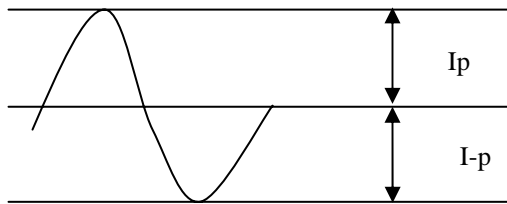

The degrees of umbalance = $\frac{|I_p - I-p|}{I_{rms}} * 100(\%)$

The ratio of wave height = $\frac{I_p \text{ (or } I-p)}{I_{rms}}$

I_p : lamp current high side peak, $I-p$: lamp current low side peak

- *6) Definition of starting lamp voltage means max. voltage of starting lamp. Starting Lamp Voltage: $V_s = \text{initial value } V_s$. We suggest the inverter starting voltage greater than max. voltage of starting lamp to certify starting lamp stability.

4. INTERFACE CONNECTION

(1) CN1 (INTERFACE SIGNAL)

- Connector type : 093B30_B000RA (STARCONN)
- Corresponding connector type : FI-X30M (JAE,FPC Type) 、 FI-X30H (JAE,wire)

pin	Symbol	Function
1	VSS	Ground
2	VCC	+3.3V
3	VCC	+3.3V
4	V_EDID	DDC 3.3V Power
5	NC	VCOM test provided , but customer-end unused (open)
6	CLK_EDID	DDC Clock
7	DATA_EDID	DDC Data
8	Link 0-(Odd)	LVDS Receiver Signal(-): Odd R0-R5,G0[Note]
9	Link 0+(Odd)	LVDS Receiver Signal(+): Odd R0-R5,G0[Note]
10	GND	Ground
11	Link 1-(Odd)	LVDS Receiver Signal(-): Odd G1-G5,B0-B1[Note]
12	Link 1+(Odd)	LVDS Receiver Signal(+): Odd G1-G5,B0-B1[Note]
13	GND	Ground
14	Link 2-(Odd)	LVDS Receiver Signal(-): Odd B2-B5,HD,VD,DENA[Note]
15	Link 2+(Odd)	LVDS Receiver Signal(+): Odd B2-B5,HD,VD,DENA[Note]
16	GND	Ground
17	CLKIN-(Odd)	Odd Clock Signal(-)
18	CLKIN+(Odd)	Odd Clock Signal(+)
19	GND	Ground
20	Link 0-(Even)	LVDS Receiver Signal(-): Even R0-R5,G0[Note]
21	Link 0+(Even)	LVDS Receiver Signal(+): Even R0-R5,G0[Note]
22	GND	Ground
23	Link 1-(Even)	LVDS Receiver Signal(-): Even G1-G5,B0-B1[Note]
24	Link 1+(Even)	LVDS Receiver Signal(+): Even G1-G5,B0-B1[Note]
25	GND	Ground
26	Link 2-(Even)	LVDS Receiver Signal(-): Even B2-B5
27	Link 2+(Even)	LVDS Receiver Signal(+): Even B2-B5
28	GND	Ground
29	CLKIN-(Even)	Even Clock Signal(-)
30	CLKIN+(Even)	Even Clock Signal(+)

[Note] DDC : Display Data Requirements

[Note] Refer to data mapping

(2) CN2 (BACK LIGHT)

- Backlight-side connector : BHSR-02VS-1(JST made)
- Inverter-side connector : SM02B-BHSS-1(JST made)

Pin No.	Symbol	Function
1	CTH	VBLH (High voltage)
2	CTL	VBLL (Low voltage)

[Note] VBLH-VBLL = VL

5. Input Signal Timing (DE mode only)

(1) LVDS Input Signal Timing Chart

(1-1) Vertical Timing sequence

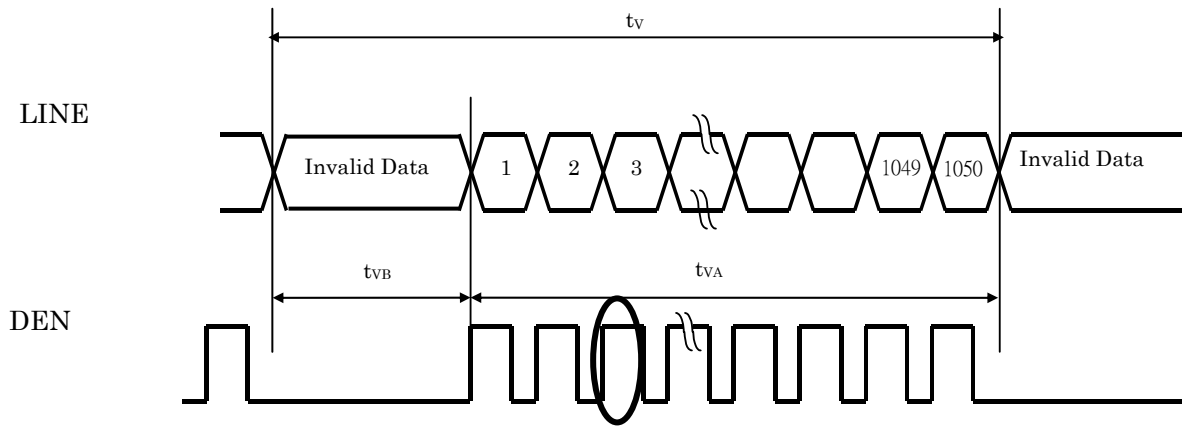

(1-2) Horizontal Timing sequence

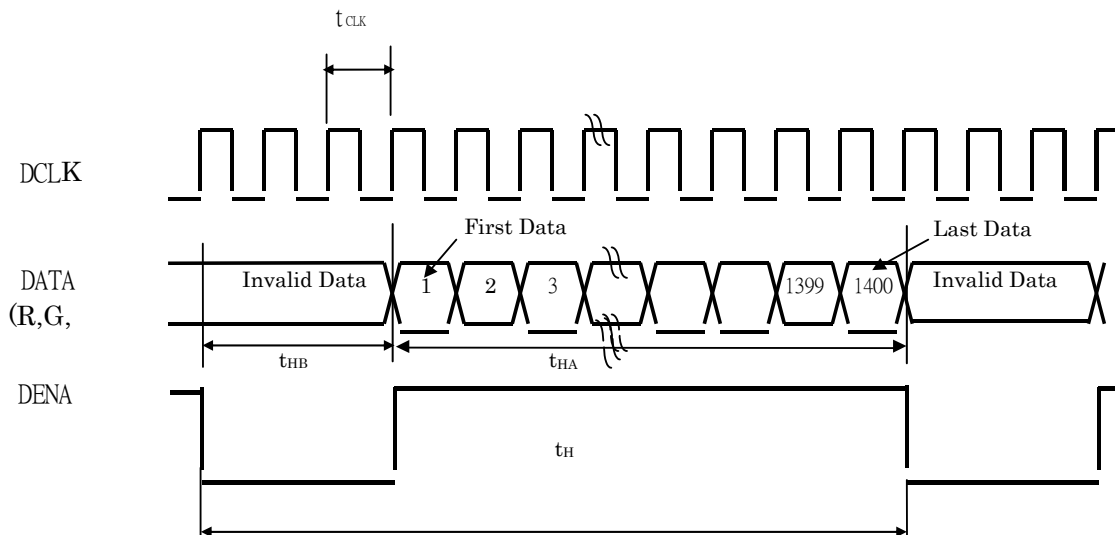

DATA, DENA
LVDS transition
(1-3) Pixel format

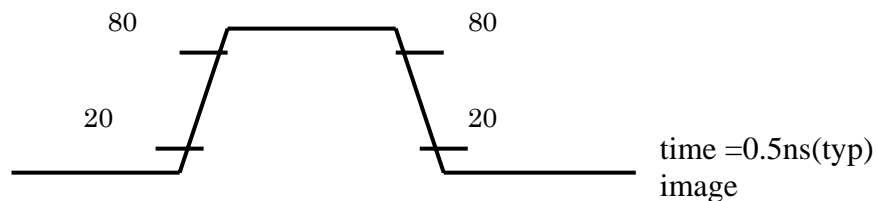

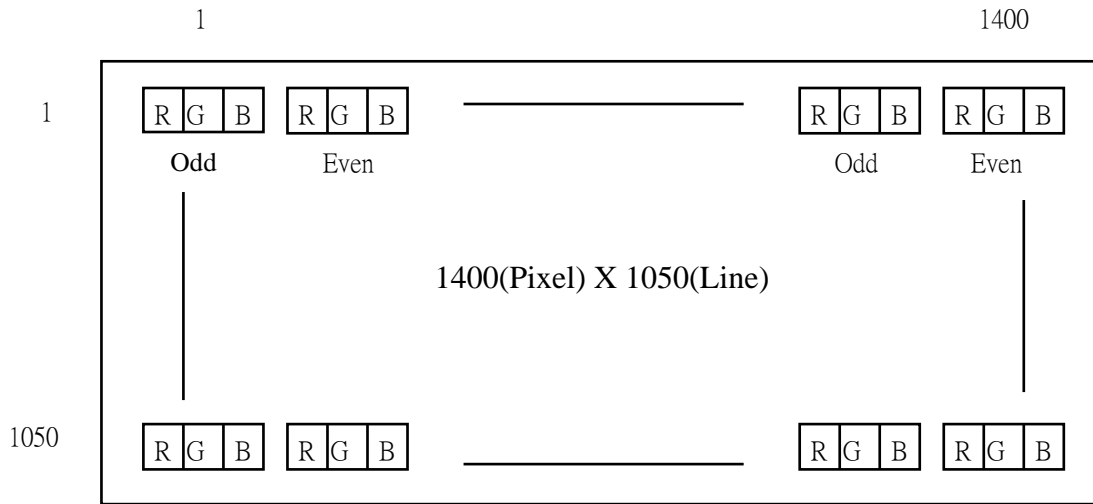

(2)Data mapping:

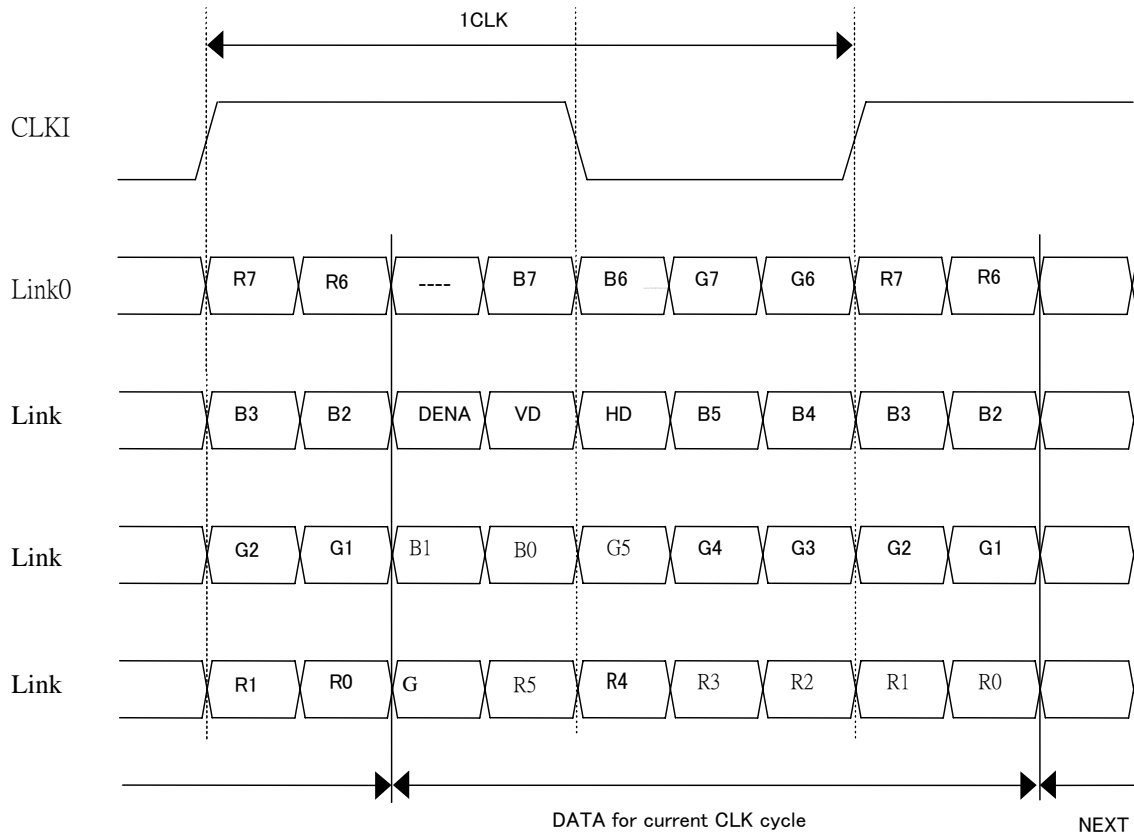

(3)Timing Specifications (DE mode only)

ITEM		SYMBOL	MIN	TYP	MAX	UNIT	
LCD input signal	DCLK	frequency	f_{CLK}	45	54	67.5	MHz
		period	t_{CLK}	-	18.5	-	ns
	DENA <i>*1)</i>	Horizontal total Time	t_H	786	831	-	t_{CLK}
		Horizontal Active Time	t_{HA}	700	700	700	t_{CLK}
		Horizontal Blank Time	t_{HB}	-	131	-	t_{CLK}
		Vertical frame Rate	Fr	55	60	75	Hz
		Vertical total Time	t_V	1051	1066	-	t_H
		Vertical Active Time	t_{VA}	1050	1050	1050	t_H
Vertical Blank Time	t_{VB}	-	16	-	t_H		
LVDS Input Timing	CLK frequency	f_{CLKin}	—	54	67.5	MHz	
	CLK period	t_{CLKin}		18.5	—	ns	

[Note]

*1) DENA (Data Enable) should always be positive polarity as shown in the timing specification.

(4) Color data definition

Color	Input Data	R DATA						G DATA						B DATA					
		R5	R4	R3	R2	R1	R0	G5	G4	G3	G2	G1	G0	B5	B4	B3	B2	B1	B0
		MSB					LSB	MSB					LSB	MSB					LSB
Basic Color	Black	0	0	0	0	0	0	0	0	0	0	0	0	0	0	0	0	0	0
	Red(63)	1	1	1	1	1	1	0	0	0	0	0	0	0	0	0	0	0	0
	Green(63)	0	0	0	0	0	0	1	1	1	1	1	1	0	0	0	0	0	0
	Blue(63)	0	0	0	0	0	0	0	0	0	0	0	0	1	1	1	1	1	1
	Cyan	0	0	0	0	0	0	1	1	1	1	1	1	1	1	1	1	1	1
	Magenta	1	1	1	1	1	1	0	0	0	0	0	0	1	1	1	1	1	1
	Yellow	1	1	1	1	1	1	1	1	1	1	1	1	0	0	0	0	0	0
	White	1	1	1	1	1	1	1	1	1	1	1	1	1	1	1	1	1	1
RED	RED(0)	0	0	0	0	0	0	0	0	0	0	0	0	0	0	0	0	0	0
	RED(1)	0	0	0	0	0	1	0	0	0	0	0	0	0	0	0	0	0	0
	RED(2)	0	0	0	0	1	0	0	0	0	0	0	0	0	0	0	0	0	0
	/	/	/	/	/	/	/	/	/	/	/	/	/	/	/	/	/	/	/
	/	/	/	/	/	/	/	/	/	/	/	/	/	/	/	/	/	/	/
	RED(62)	1	1	1	1	1	0	0	0	0	0	0	0	0	0	0	0	0	0
	RED(63)	1	1	1	1	1	1	0	0	0	0	0	0	0	0	0	0	0	0
Green	Green(0)	0	0	0	0	0	0	0	0	0	0	0	0	0	0	0	0	0	0
	Green(1)	0	0	0	0	0	0	0	0	0	0	0	1	0	0	0	0	0	0
	Green(2)	0	0	0	0	0	0	0	0	0	0	1	0	0	0	0	0	0	0
	/	/	/	/	/	/	/	/	/	/	/	/	/	/	/	/	/	/	/
	/	/	/	/	/	/	/	/	/	/	/	/	/	/	/	/	/	/	/
	Green(62)	0	0	0	0	0	0	1	1	1	1	1	0	0	0	0	0	0	0
	Green(63)	0	0	0	0	0	0	1	1	1	1	1	1	0	0	0	0	0	0
Blue	Blue(0)	0	0	0	0	0	0	0	0	0	0	0	0	0	0	0	0	0	0
	Blue(1)	0	0	0	0	0	0	0	0	0	0	0	0	0	0	0	0	0	1
	Blue(2)	0	0	0	0	0	0	0	0	0	0	0	0	0	0	0	0	1	0
	/	/	/	/	/	/	/	/	/	/	/	/	/	/	/	/	/	/	/
	/	/	/	/	/	/	/	/	/	/	/	/	/	/	/	/	/	/	/
	Blue(62)	0	0	0	0	0	0	0	0	0	0	0	0	1	1	1	1	1	0
	Blue(63)	0	0	0	0	0	0	0	0	0	0	0	0	1	1	1	1	1	1

[Note]

(1) Definition of gray scale:

Color(n) : n means level of gray scale .

Larger n means brighter level.

(2) Data : 1= High , 0 = Low

6. BLOCK DIAGRAM

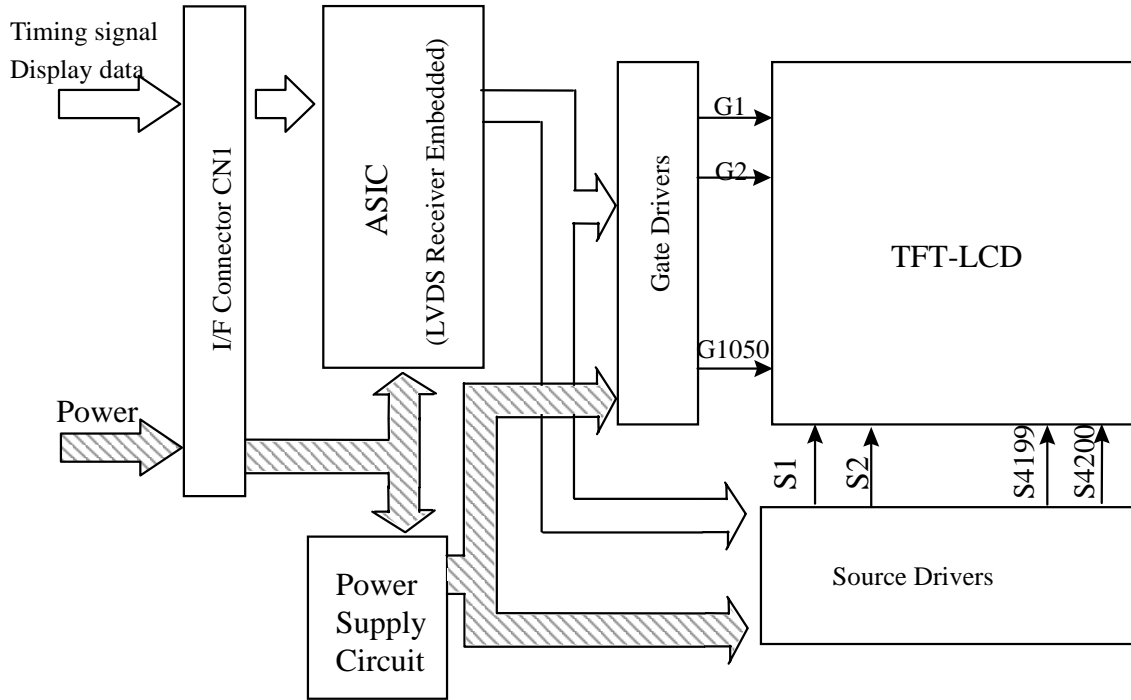

BACK LIGHT

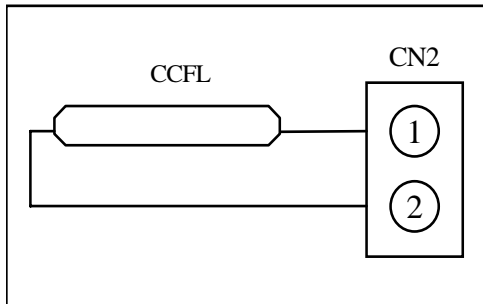

INVERTER CIRCUIT (OUT SIDE)

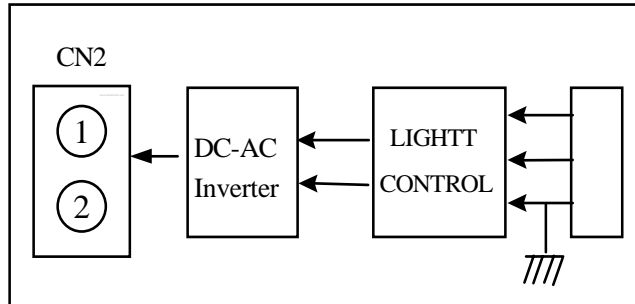

7. MECHANICAL DIMENSION

(1) Front side

Unit:mm

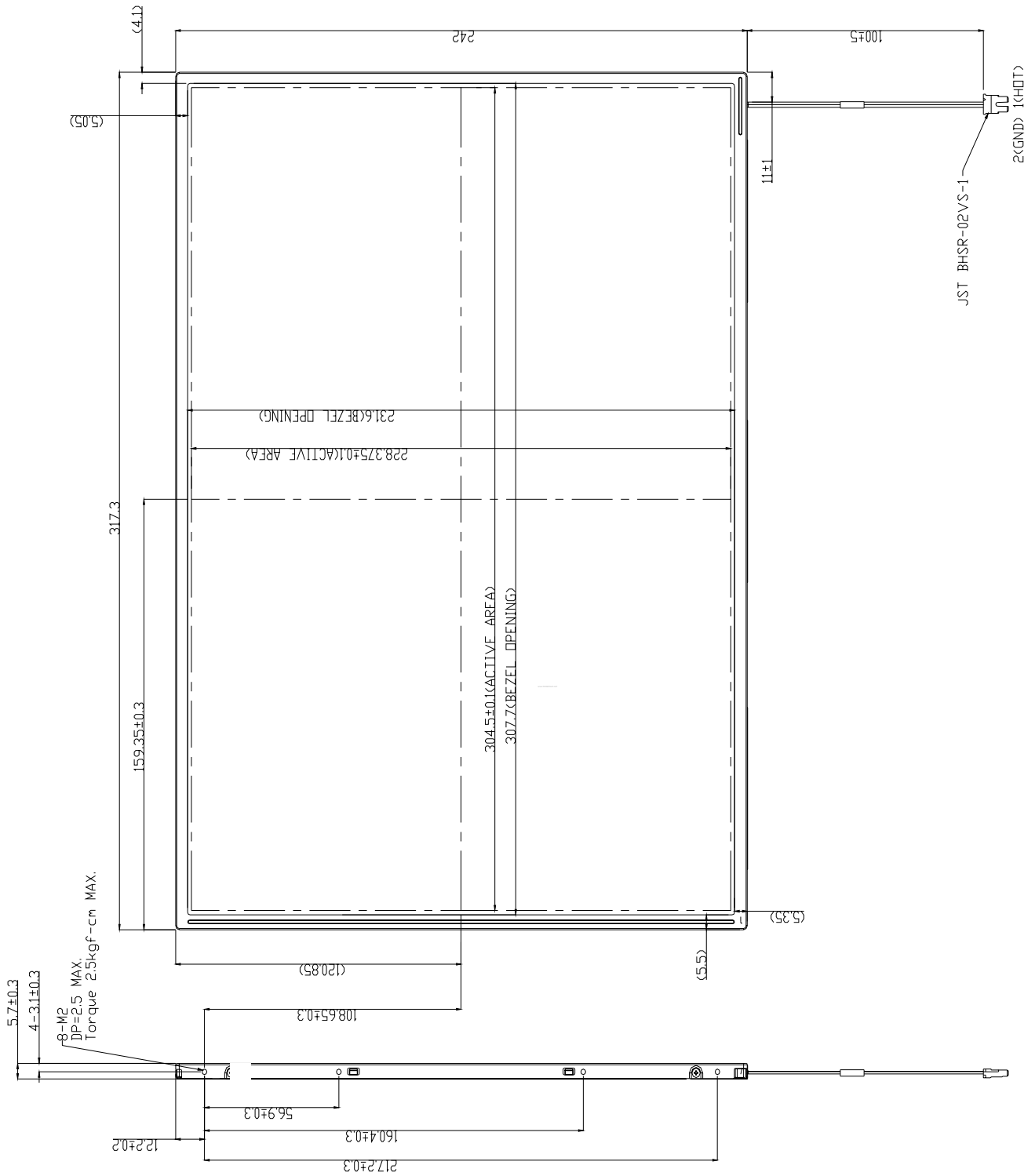

[Note] Undefined tolerances to be ± 0.5 mm

(2) Rear side

Unit : mm

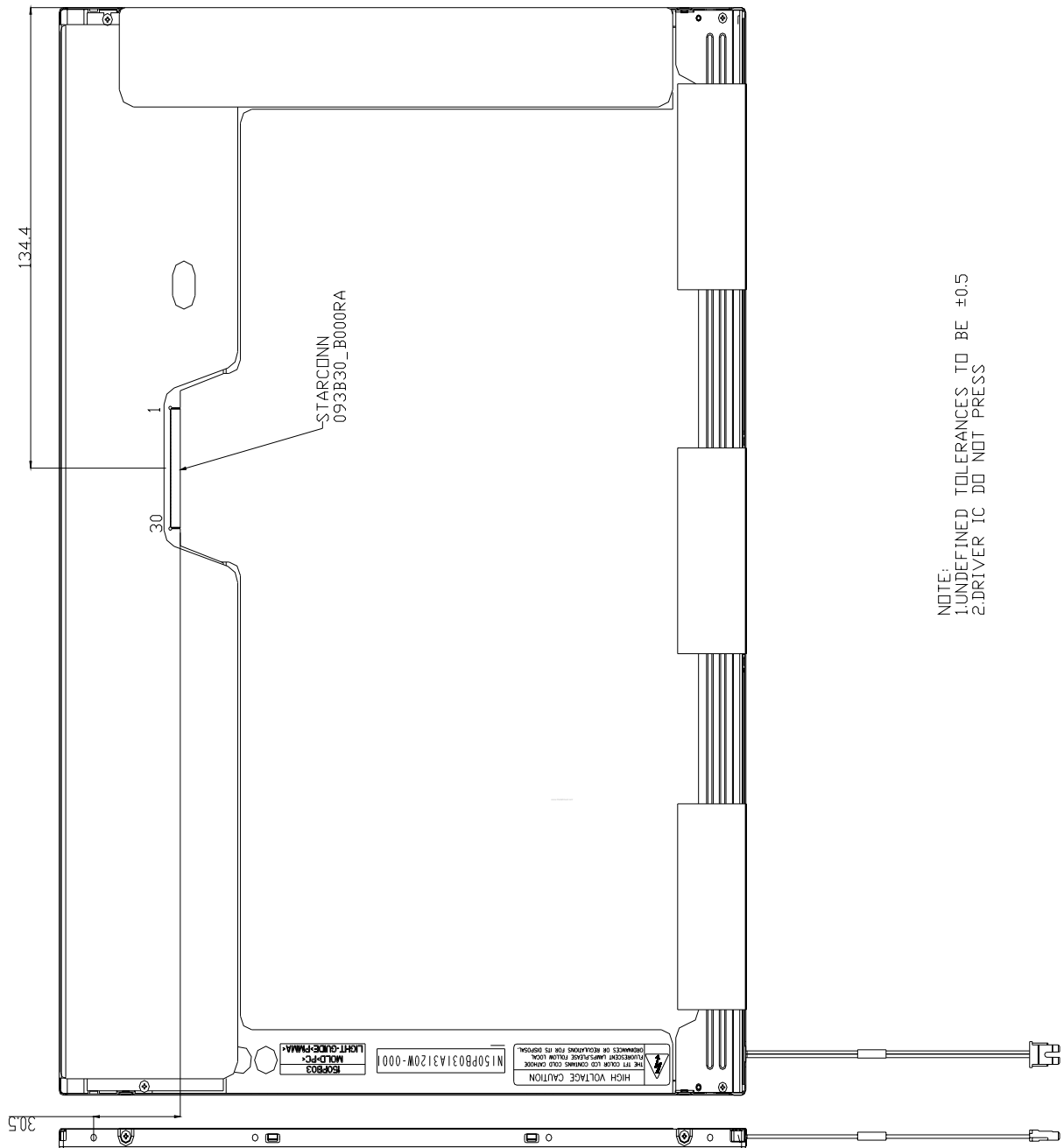

[Note] Undefined tolerances to be ± 0.5 mm

8. OPTICAL CHARACTERISTICS*1) *2) *3)

Ta = 25°C, Vcc=3.3V

ITEM	SYMBOL	CONDITION	MIN.	TYP.	MAX.	UNIT	
Contrast Ratio *4)	CR	$\varphi = \theta = 0^\circ$	--	350	--	-	
Luminance (center)	L	$\varphi = \theta = 0^\circ$ $I_L = 6 \text{ mA}$	180	200	--	cd/m ²	
5 point Luminance Uniformity *5)	L	$\varphi = \theta = 0^\circ$ $I_L = 6 \text{ mA}$	160	185	--	cd/m ²	
Luminance Uniformity*6)	ΔL	$\varphi = \theta = 0^\circ$	--	--	30	%	
Response Time*7)	tr	$\varphi = \theta = 0^\circ$	--	7	10	ms	
	tf	$\varphi = \theta = 0^\circ$	--	18	20	ms	
Viewing Angle*3)	Horizontal	φ	$\varphi = \theta = 0^\circ$	--	-40 ~ 40	--	°
	Vertical	θ	$CR \geq 10$	--	-40 ~ 20	--	°
Image Sticking*8)	tis	2 hrs	--	--	2	sec	
Crosstalk modulation Ratio*9)	CTR		--	--	1	%	
Color Coordinate	Red	X	$\theta = \phi = 0^\circ$	0.574	0.604	0.634	-
		y		0.298	0.328	0.358	
	Green	x		0.280	0.310	0.340	
		y		0.543	0.573	0.603	
	Blue	x		0.125	0.155	0.185	
		y		0.114	0.144	0.174	
	White	x		0.283	0.313	0.343	
		y		0.299	0.329	0.359	

[Note]

*1) These items are measured by BM-5A(TOPCON) in the dark room .(no ambient light).

*2) Brightness conditions : Inverter : SUMIDA IV11145T (61K)

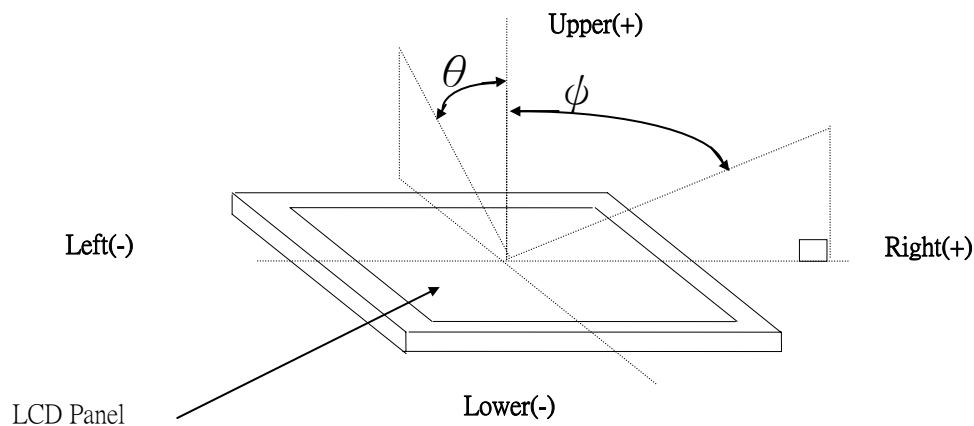
*3) Definition of Viewing Angle(θ , ϕ)

*4) CR : measures 5 points and take the average value.

The Definition of Contrast Ratio is as follows:

$$CR = \frac{\text{(White)Luminance of ON}}{\text{(Black)Luminance OFF}}$$

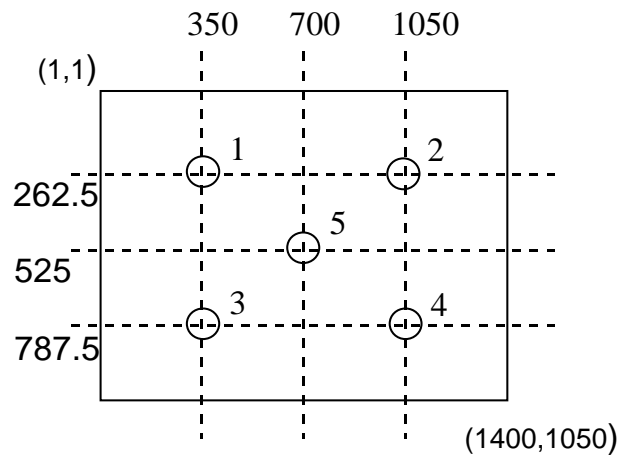

*5) 5 point Luminance Uniformity : Measure white Luminance on the same 5 points and take the average value.

*6) Definition of Luminance Uniformity

$$\Delta L = [L(\text{MAX}) / L(\text{MIN}) - 1] \times 100$$

*7) Definition of Response Time :

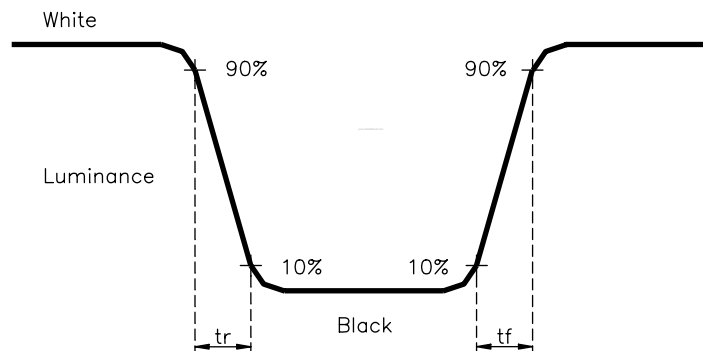

*8) Definition of Image Sticking : Continuously display the test pattern shown in the figure below for two-hours. Then switch to full white screen. It changes from test pattern to white pattern. The previous image should not persist more than two seconds at 25°C .

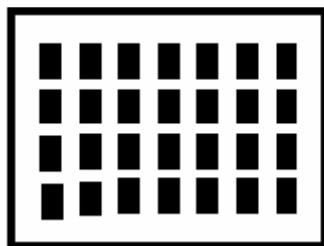

*9) Definition of Cross talk Modulation Ratio

$$CTR = \text{MAX} ((/ (Lb1 - La) / Lc /) \times 100 , (/ (Lb2 - La) / Lc /) \times 100)$$

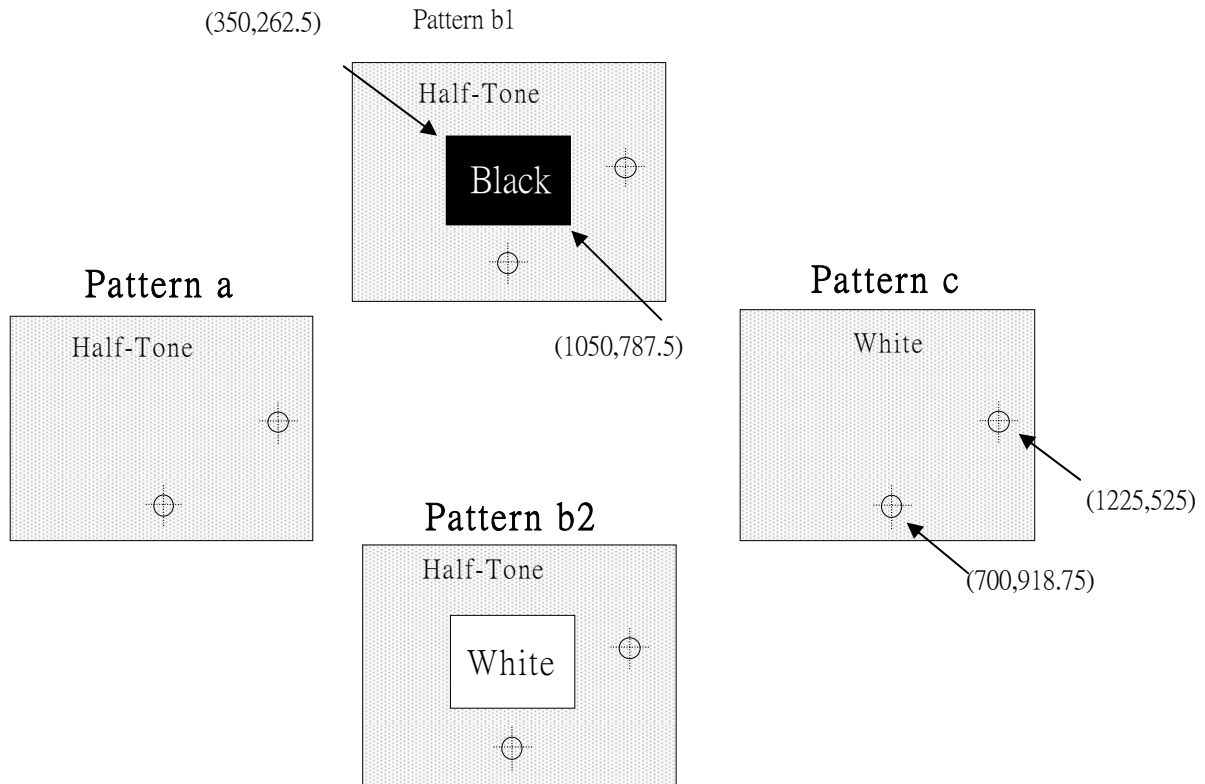

9. RELIABILITY TEST CONDITIONS

(1) Temperature and Humidity

TEST ITEMS	CONDITIONS
HIGH TEMPERATURE OPERATION	50°C ,240h
HIGH TEMPERATURE STORAGE	60°C ,240h
LOW TEMPERATURE OPERATION	0°C ,240h ; Backlight unit always turn on
LOW TEMPERATURE STORAGE	-20°C ,240h
HIGH TEMPERATURE HIGH HUMIDITY OPERATION	50°C ,90%RH,240h(No condensation)
HIGH TEMPERATURE HIGH HUMIDITY STORAGE	60°C ,90%RH(Max),48h(No condensation)
THERMAL SHOCK (No operation)	BETWEEN -20°C (1h)AND 60°C (1h),100 CYCLES

(2) Shock & Vibration

ITEMS	CONDITIONS
SHOCK (NON-OPERATION)	<ul style="list-style-type: none"> ● Shock level: 2156 m/s² (220G) ● Waveform: half sinusoidal wave, 2ms ● Number of shocks: one shock input in each direction of three mutually perpendicular axes for a total of six shock inputs.
VIBRATION (NON-OPERATION)	<ul style="list-style-type: none"> ● Vibration level: 14.7m/s² (1.5G) , sinusoidal wave, perpendicular axis(each x,y,z axis: 0.5hr , total 1.5 hrs) ● Frequency range: 5 to 500 Hz ● Sweep speed : 0.5 octave / min

(3) Electrostatic Discharge

TEST ITEM	CONDITIONS
ESD	150pF , 330Ω , ±15KV air & ±8KV contact test*1)
	200pF , 0Ω , ±250V contact test*2)

[Note]

*1) Measure point : LCD glass and metal bezel

*2) Measure point : IF connector pins

(4) Judgment standard

The judgment of the above test should be made as follow:

Pass: Normal display image with no obvious non-uniformity and no line defect.

Partial transformation of the module parts should be ignored.

Fail : No display image, obvious non-uniformity, or line defects.

10. HANDLING PRECAUTIONS FOR TFT-LCD MODULE

Please pay attention to the followings in handling- TFT-LCD products:

(A) ASSEMBLY PRECAUTION

- (1) Please use the mounting hole on the module side in installing and do not beading or wrenching LCD in assembling. And please do not drop, bend or twist LCD module in handling.
- (2) Please design display housing in accordance with the following guidelines.
 - (2.1) Housing case must be destined carefully so as not to put stresses on LCD all sides and not to wrench module. The stresses may cause non-uniformity even if there is no non-uniformity statically.
 - (2.2) Keep sufficient clearance between LCD module back surface and housing when the LCD module is mounted. Approximately 1.0 mm of the clearance in the design is recommended taking into account the tolerance of LCD module thickness and mounting structure height on the housing.
 - (2.3) When some parts, such as, FPC cable and ferrite plate, are installed underneath the LCD module, still sufficient clearance is required, such as 0.5mm. This clearance is, especially, to be reconsidered when the additional parts are implemented for EMI countermeasure.
 - (2.4) Design the inverter location and connector position carefully so as not to give stress to lamp cable, or not to interface the LCD module by the lamp cable.
 - (2.5) Keep sufficient clearance between LCD module and the others parts, such as inverter and speaker so as not to interface the LCD module. Approximately 1.0mm of the clearance in the design is recommended.
- (3) Please do not push or scratch LCD panel surface with any-thing hard. And do not soil LCD panel surface by touching with bare hands. (Polarizer film, surface of LCD panel is easy to be flawed.)
- (4) Please do not press any parts on the rear side such as source TCP, gate TCP, control circuit board and FPCs during handling LCD module. If pressing rear part is unavoidable, handle the LCD module with care not to damage them.
- (5) Please wipe out LCD panel surface with absorbent cotton or soft of cloth in case of it being soiled.
- (6) Please wipe out drops of adhesives like saliva and water on LCD panel surface immediately. They might damage to cause panel surface variation and color change.
- (7) Please do not take a LCD module to pieces and reconstruct it. Resolving and reconstructing modules may cause them not to work well.
- (8) Please do not touch metal frames with bare hands and soiled gloves. A color change of the metal frames can happen during a long preservation of soiled LCD modules.
- (9) Please pay attention to handling lead wire of backlight so that it is not tugged in connecting wit inverter.

(B) OPERATING PRECAUTIONS

- (1) Please be sure to turn off the power supply before connecting and disconnecting signal input cable.
- (2) Please do not change variable resistance settings in LCD module. They are adjusted to the most suitable value. If they are changed, it might happen LCD does not satisfy the characteristics specification.
- (3) Please consider that LCD backlight takes longer time to become stable of radiation characteristics in low temperature than in room temperature.
- (4) A condensation might happen on the surface and inside of LCD module in case of sudden charge of ambient temperature.
- (5) Please do not display the same pattern for very long time. Image might stick on LCD.

- (6) Please obey the same caution descriptions as ones that need to pay attention to ordinary electronic parts.

(C) PRECAUTIONS WITH ELECTROSTATICS

- (1) This LCD module use CMOS-IC on circuit board and TFT-LCD panel, and so it is easy to be affected by electrostatics. Please be careful with electrostatics by the way of your body connecting to the ground and so on.
- (2) Please remove protection film very slowly on the surface of LCD module to prevent from electrostatics occurrence.

(D) STORAGE PRECAUTIONS

- (1) When you store LCDs for a long time, it is recommended to keep the temperature between 0°C~40°C without the exposure of sunlight and to keep the humidity less than 90%RH.
- (2) Please do not leave the LCDs in the environment of high humidity and high temperature such as 60°C 90%RH.
- (3) Please do not leave the LCDs in the environment of low temperature below -20°C.

(E) SAFETY PRECAUTIONS

- (1) When you waste LCDs, it is recommended to crush damaged or unnecessary LCDs into pieces and wash them off with solvents such as acetone and ethanol, which should later be burned.
- (2) If any liquid leaks out of a damaged-glass cell and comes in contact with the hands, wash off thoroughly with soap and water.

(F) OTHERS

- (1) A strong incident light into LCD panel might cause display characteristics' changing inferior because of polarizer film, color filter, and other materials becoming inferior. Please do not expose LCD module direct sunlight and strong UV rays.
- (2) Please pay attention to a panel side of LCD module not to contact with other materials in preserving it alone.
- (3) For the packaging box, please pay attention to the followings:
 - (3.1) Packaging box and inner case for LCD are designed to protect the LCDs from the damage or scratching during transportation. Please do not open except picking LCDs up from the box.
 - (3.2) Please do not pile them up more than 5 boxes. (They are not designed so.) And please do not turn over.
 - (3.3) Please handle packaging box with care not to give them sudden shock and vibrations. And also please do not throw them up.
 - (3.4) Packing box and inner case for LCDs are made of cardboard. So please pay attention not to get them wet. (Such like keeping them in high humidity or wet place can occur getting them wet.)