



Chunghwa Picture Tubes, Ltd.

Technical Specification

Date : 2004/04/26

CPT TFT-LCD

CLAA150XP 01Y

ACCEPTED BY :

APPROVED BY	CHECKED BY	PREPARED BY
		TFT-LCD Product Planning Management General Division

CHUNGHWA PICTUER TUBES, LTD.

1127 Hopin Rd., Padeh, Taoyuan, Taiwan 334, R.O.C.
TEL: +886-3-3675151 FAX: +886-3-377-3001

Doc.No:	CLAA150XP01Y-VER1-2004/04/26	Issue Date:	2004/04/26
---------	------------------------------	-------------	------------

T- 3650002- 000- A
NEW

1. OVERVIEW

CLAA150XP01 is 15" color TFT-LCD (Thin Film Transistor Liquid Crystal Display) module composed of LCD panel, LVDS driver ICs, control circuit and backlight. By applying 8 bit digital data, 1024×768, 16.2M-color images are displayed on the 15" diagonal screen. Interface of data and control signals is Typ. 65 MHz digital. Inverter for backlight is not included in this module. General specification are summarized in the following table:

ITEM	SPECIFICATION
Display Area (mm)	304.1(H)x228.1(V) (15.0-inch diagonal)
Number of Pixels	1024 (H) × 768(V)
Pixel Pitch (mm)	0.297(H) × 0.297(V)
Color Pixel Arrangement	RGB vertical stripe
Display Mode	Normally white, TN
Number of Colors	16.2M(6bits+FRC)
Brightness (cd/m ²)	250cd/m ² (Typ.)(center, 8.0mA)
Viewing Angle	140/125(Typ.)
Wide Viewing Angle Technology	Optical Compensation Film
Surface Treatment	Anti-glare
Response Time	16ms
Color Saturation	65%
Total Module Power (W)	10.4+2.1(Typ.)
Optimum Viewing Angle	6 o'clock
Module Size (mm)	326.5(W) × 253.5(H) × 11.0(D) (Typ.)
Module Weight (g)	1060(Typ.)
Backlight Unit	CCFL, 2 tables, edge-light (top/bottom)

The LCD Products listed on this document are not suitable for use of aerospace equipment, submarine cables, and nuclear reactor control system and life support systems. If customers intend to use these LCD products for above application or not listed in "Standard" as follows, please contact our sales people in advance.

Standard: Computer, Office equipment, Communication equipment, Test and Measurement equipment, Machine tool, Industrial robot, Audio and Visual equipment, Other consumer products.

2. ABSOLUTE MAXIMUM RATINGS

The following are maximum values which, if exceeded, may cause faulty operation or damage to the unit.

ITEM	SYMBOL	MIN.	MAX.	UNIT	Remark
Power Supply Voltage For LCD	VDDD	-	4.0	V	
IDDD Rush Current	IRUSHd	-	4.0	A	*1)
Lamp Voltage	VL	522	700	Vrms	
Lamp Current	IL	3	8.5	mArms	
Lamp Frequency	FL	40	80	kHz	
Operation Temperature (Surrounding) *1)	T _{op}	0	50		*2), 3), 4), 5)
Storage Temperature *1)	T _{stg}	-20	60		*2), 3), 4)

[Note]

*1) In 100 μsec , but in the situation of longer VDD rising time, the RUSH value will get smaller.

*2) The relative temperature and humidity range are as below sketch, 90%RHMax. (Ta 40)

*3) The maximum wet bulb temperature 39 (Ta > 40) and without dewing.

*4) If you use the product in a environment which over the definition of temperature and humidity too long to effect the result of eye-atching.

*5) If you operate the product in normal temperature range, the center surface of panel should be under 60 :

Humidity :

Humidity 85%RH without condensation.

Relative Humidity 90% (Ta 40)

Wet Bulb Temperature 39 (Ta 40)

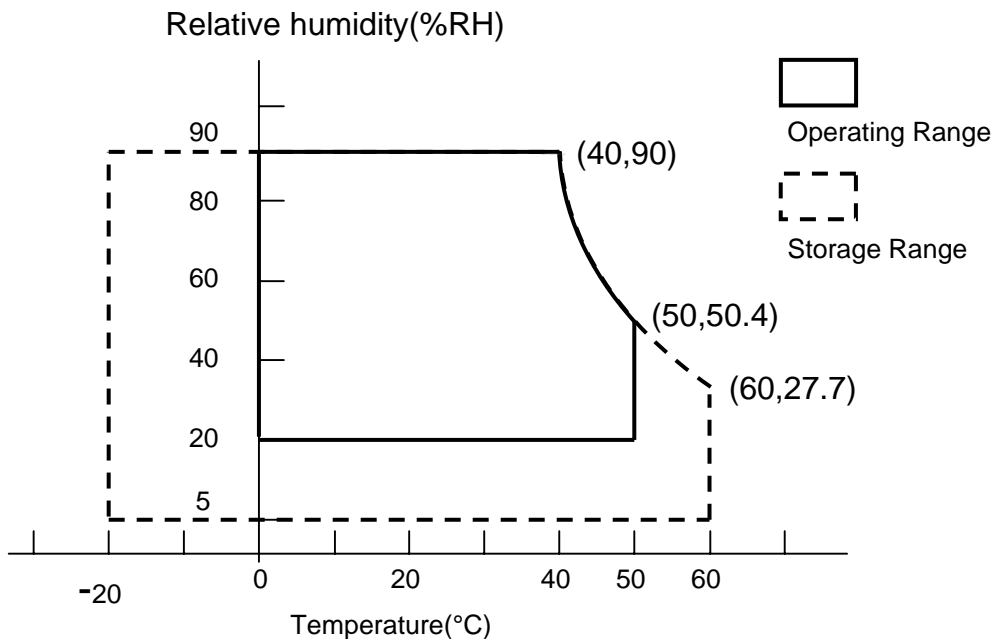

3. ELECTRICAL CHARACTERISTICS

3.1 TFT-LCD

Ta=25

ITEM	SYMBOL	MIN	TYP	MAX	UNIT	REMARK
Power Supply Voltage for Logic	VDDD	3.0	3.3	3.6	V	*1)
Power Supply Current for Logic	IDDD	--	600	700	mA	*2)
Permissible Ripple Voltage for Logic	VRPd	--	--	100	mVp-p	Vin=+3.3V
Differential impedance	Zm	90	100	110		*3)

[Note]

*1)Power、 data sequence

t1 10ms 1 sec t4
 0 < t2 50ms 200ms t5
 0 < t3 50ms 200ms t6

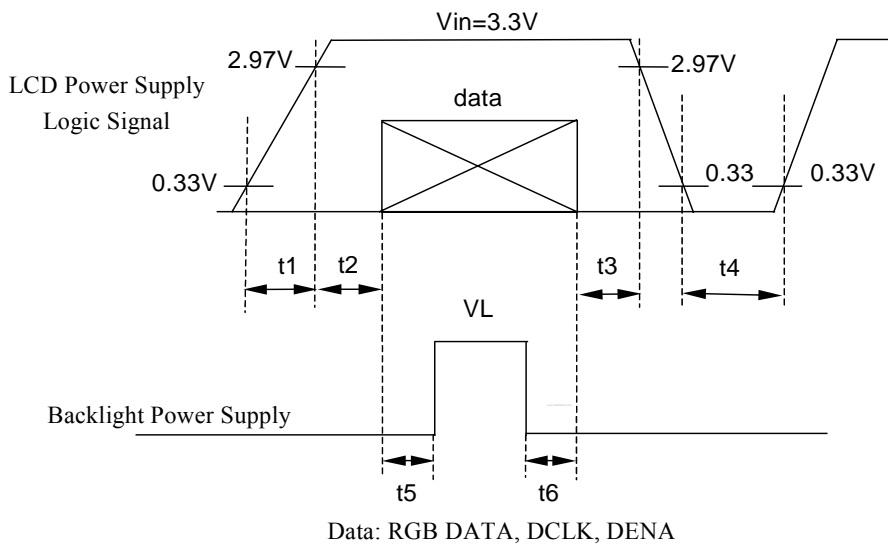

VCC-dip state :

- 1) When 2.4 V $V_{CC} < 3.0V$, $t_d = 10$ ms.
- 2) VCC-dip condition should also follow the VCC-turn-off condition.

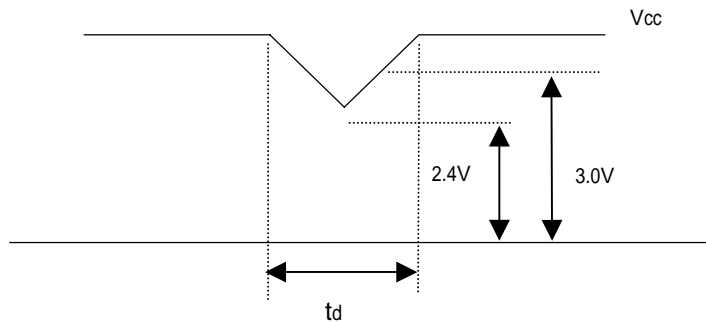

*2) Typical current situation: 0~255-gray-bar pattern, 768 line mode, $V_{CC}=+3.3V$, $f_{CLK}=65$ MHz.

*3) Definition of the LVDS data

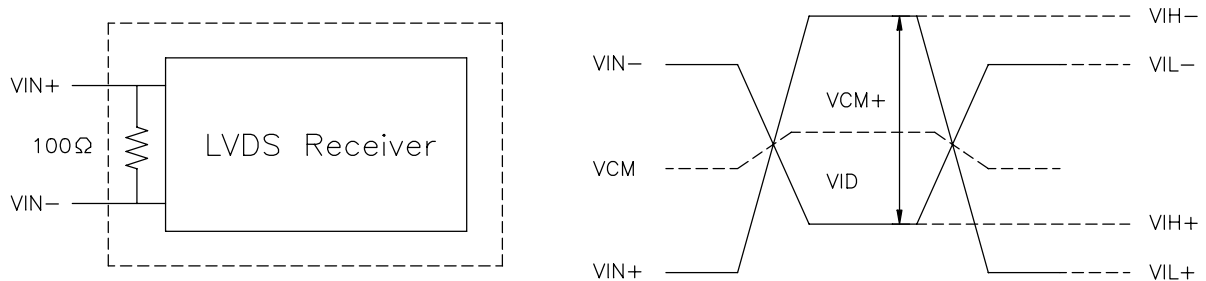

VIN+ : Positive differential DATA & CLK input

VIN- : Negative differential DATA & CLK input

$$VID = VIN_+ - VIN_-$$

$$VCM = |VIN_+ - VCM_-|$$

$$VID = |VIN_+ - VID_-|$$

$$VID_+ = |VIN_+ - VIH_-|$$

$$VID_- = |VIN_+ - VIL_-|$$

$$VCM = (VIN_+ + VIN_-)/2$$

$$VCM_+ = (VIN_+ + VIH_-)/2$$

$$VCM_- = (VIN_+ + VIL_-)/2$$

3.2 Backlight

(a) Electrical Characteristics

Ta=25

ITEM	SYMBOL	MIN	TYP	MAX	UNIT	REMARK
Lamp Voltage	VL	522	580	638	Vrms	IL=8.0mA
Lamp Current	IL	6	8.0	8.5	mArms	*1)
Inverter Frequency	FI	40	50	60	kHz	*2)
Starting Lamp Voltage	VS	1280	--	--	Vrms	Ta=0
		985	--	--	Vrms	Ta=25

(b) Lamp Life Time

ITEM	IL @3.0 mA	IL @8.0 mA	IL @8.5 mA	UNIT	REMARK
Lamp Life Time	Min. 50,000	Min. 30,000	Min. 20,000	hr	Continuous Operation*3)
Turn-on and Turn-off Operation	--	Min. 100,000	--	time	Continuous Operation*4)

[Note] If the waveform of light up-driving is asymmetric, the distribution of mercury inside the lamp tube will become unequally or will deplete the Ar gas in it. Then it may cause the abnormal phenomenon of lighting-up. Therefore, designers have to try their best to fulfill the conditions under the inverter designing-stage as below:

The degrees of unbalance : < 10%

The ratio of wave height : < 2 ±10%

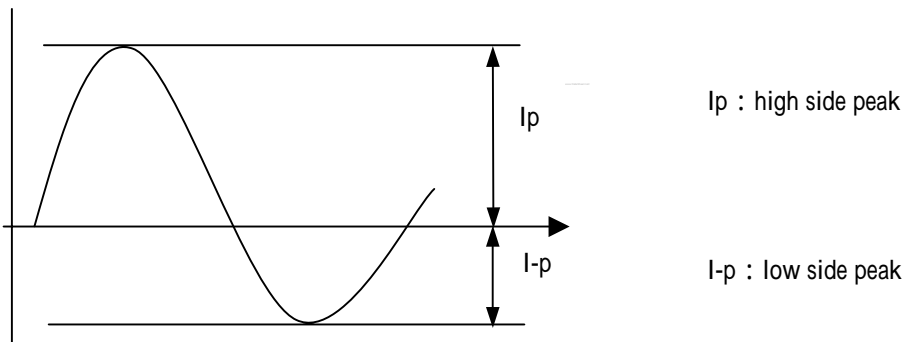

A : The degrees of unbalance = $| Ip - I-p | / Irms \times 100 (\%)$

B : The ratio of wave height = $Ip \text{ (or } I-p) / Irms$

*1) Lamp Current measurement method (The current meter is inserted in cold line)

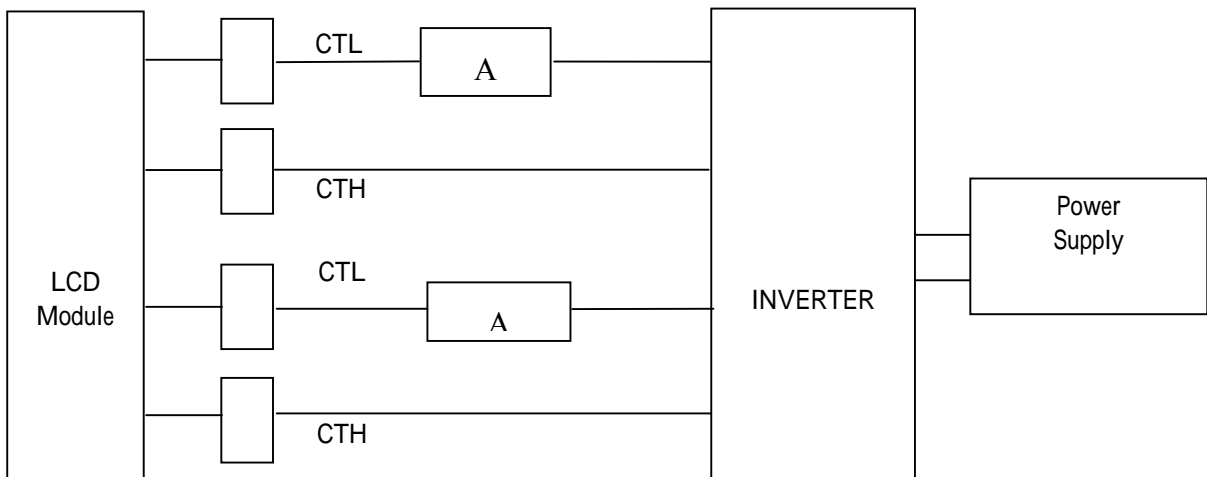

*2) Frequency in this range can mala the characterisitics of electric and optics maintain in +/- 10% except hue.

Lamp frequency of inverter may produce interference with horizontal synchronous frequency, and this may cause horizontal beat on the display. Therefore, please adjust lamp frequency, and keep inverter as far from module as possible or use electronic shielding between inverter and module to avoid the interference.

*3) Definition of the lamp life time :

a. Luminance (L) under 50% of specification starting lamp voltage

b. Starting Lamp Voltage: VS < 985V, Ta=25

VS < 1280V, Ta=0

When lamp current over 8.0mA, lamp life time will drop rapidly. If over 8.5mA, it will come up safety issue. But if it lower than 3.0mA, the lamp will be damaged.

*4) The condition of Turn-on and Turn-off operation is as below:

a. Lamp current is 8.0mA

b. Frequency is 10 sec.(on)/10 sec.(off)

c. Repeat it for 10 thousand times

d. The lamp hue variation must smaller than 0.015

e. It should not have motion fail when starting lamp voltage is lower than 130%of the initial value.

4. INTERFACE PIN CONNECTION

4.1 CN1

Outlet connector: DF14H-20P-1. 25H

Plug connector: DF14 -20S-1.25C

PIN #	SYMBOL	FUNCTION
1	VDDD	+3.3V Power Supply
2	VDDD	+3.3V Power Supply
3	GND	GND
4	GND	GND
5	RXIN0-	Negative LVDS Differential Data Input
6	RXIN0+	Positive LVDS Differential Data Input
7	GND	GND
8	RXIN1-	Negative LVDS Differential Data Input
9	RXIN1+	Positive LVDS Differential Data Input
10	GND	GND
11	RXIN2-	Negative LVDS Differential Data Input
12	RXIN2+	Positive LVDS Differential Data Input
13	GND	GND
14	RXCLK	Negative LVDS Differential Clock Input
15	RXCLK	Positive LVDS Differential Clock Input
16	GND	GND
17	RXIN3-	Negative LVDS Differential Data Input
18	RXIN3+	Positive LVDS Differential Data Input
19	GND	GND
20	NC	Reserved

- 1) Keep the NC Pin and don't connect it to GND or other signals.
- 2) GND Pin must connect to the ground, don't let it be a vacant pin.

4.2 CN2, 3 (BACKLIGHT)

Backlight-side connector: BHR-03VS-1 (JST)

Inverter-side connector: SM03B-BHS-1-TB (JST)

CN2

PIN #	SYMBOL	FUNCTION
1	CTH1	High Voltage
2	--	Empty
3	CTL1	Low Voltage

CN3

PIN #	SYMBOL	FUNCTION
1	CTH2	High Voltage
2	--	Empty
3	CTL2	Low Voltage

5. INTERFACE TIMING

5.1 Horizontal signal:

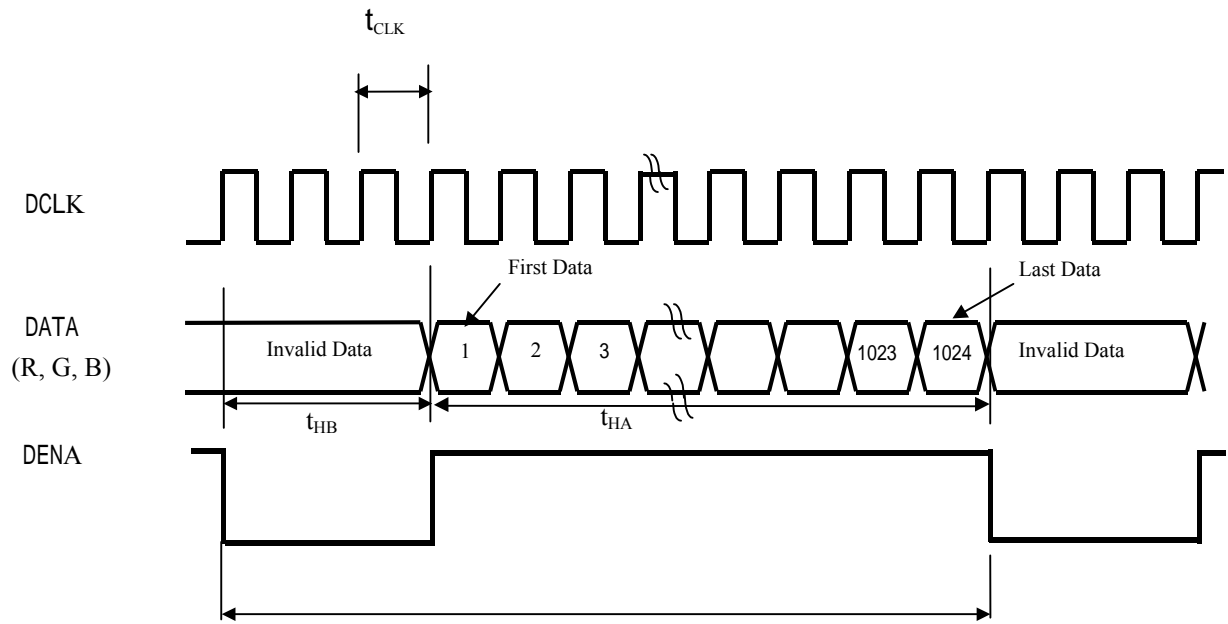

5.2 Vertical signal:

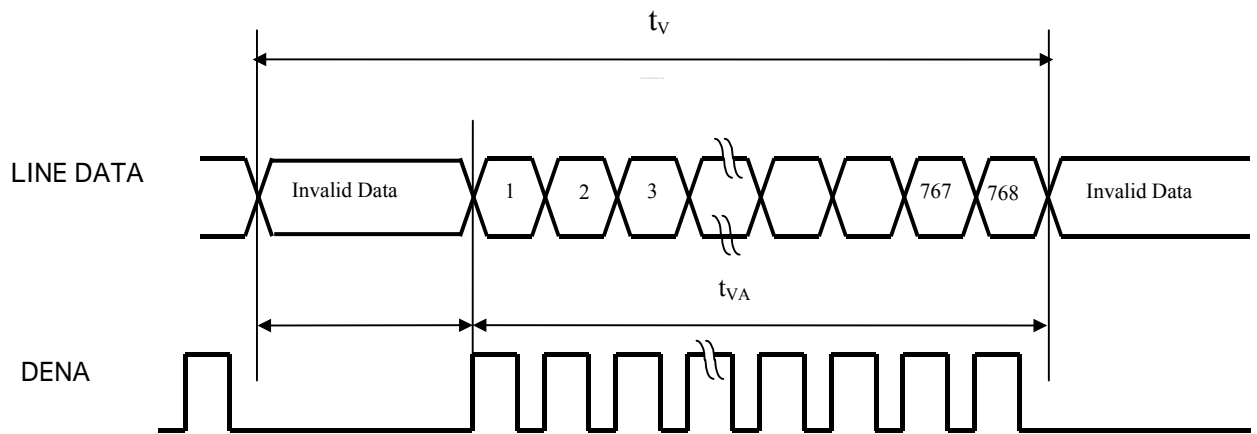

5.3 Timing Chart

ITEM		SYMBOL	MIN.	TYP.	MAX.	UNIT	
LCD Timing	DCLK	Freq.	f_{CLK}	50	65	80	MHz
		Cycle	t_{CLK}	12.5	15.3	20	ns
	Horizontal	Vertical line Rate	f_H	43.48	48.36	58.39	kHz
		Horizontal total time	t_H	1150	1344	1370	t_{CLK}
		Horizontal effective time	t_{HA}	--	1024	--	t_{CLK}
		Horizontal blank time	t_{HB}	126	320	346	t_{CLK}
	Vertical	Vertical frame Rate	Fr	55	60	75	Hz
		Vertical total time	t_V	794	806	860	t_H
		Vertical effective time	t_{VA}	--	768	--	t_H
		Vertical blank time	t_{VB}	26	38	92	t_H

CPT accepts Philips request that Frame Rate can be 50 Hz also, but CPT doesn't promise any performance and quality issue.

6.DATA MAPPING

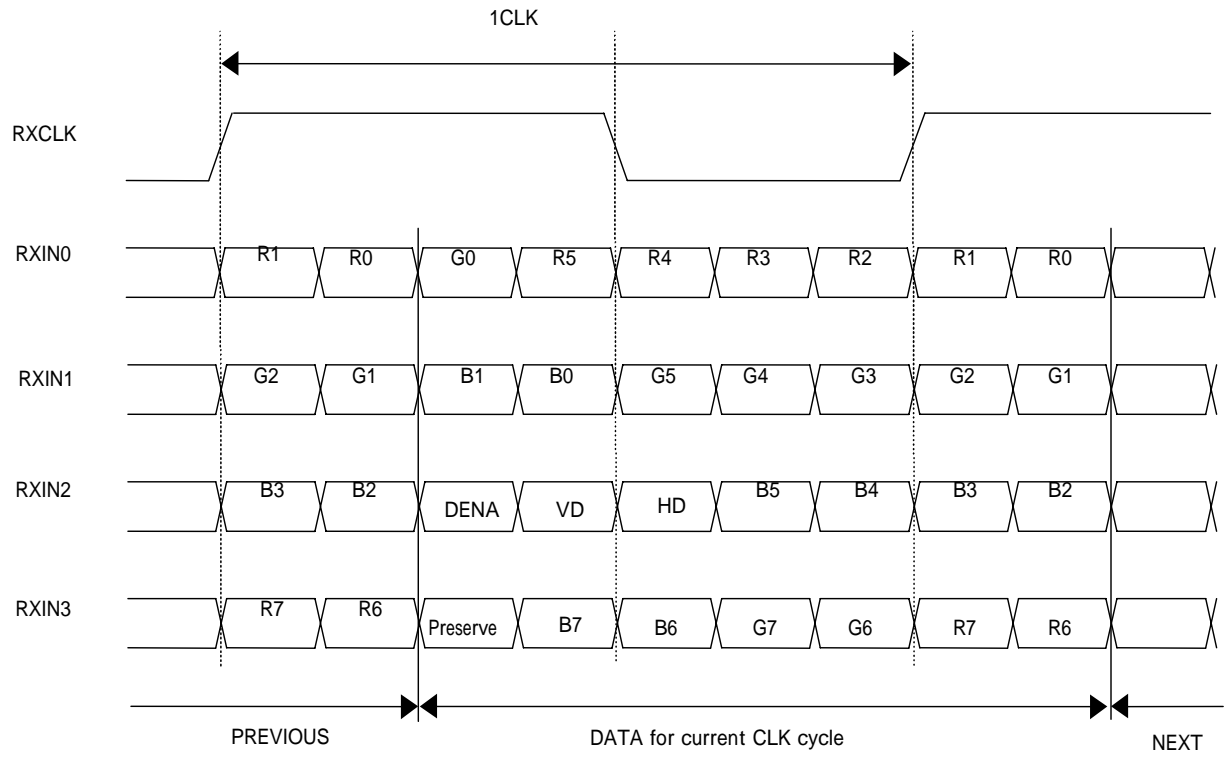

7.COLOR DATA ASSIGNMENT

7.1 Color Data Assignment

Color	Input Data	MSB								LSB								MSB								LSB							
		R7	R6	R5	R4	R3	R2	R1	R0	G7	G6	G5	G4	G3	G2	G1	G0	B7	B6	B5	B4	B3	B2	B1	B0								
Basic Color	Black	0	0	0	0	0	0	0	0	0	0	0	0	0	0	0	0	0	0	0	0	0	0	0	0								
	Red	1	1	1	1	1	1	1	1	0	0	0	0	0	0	0	0	0	0	0	0	0	0	0	0								
	Green	0	0	0	0	0	0	0	0	1	1	1	1	1	1	1	1	0	0	0	0	0	0	0	0								
	Blue	0	0	0	0	0	0	0	0	0	0	0	0	0	0	0	0	1	1	1	1	1	1	1	1								
	Cyan	0	0	0	0	0	0	0	0	1	1	1	1	1	1	1	1	1	1	1	1	1	1	1	1								
	Magenta	1	1	1	1	1	1	1	1	0	0	0	0	0	0	0	0	1	1	1	1	1	1	1	1								
	Yellow	1	1	1	1	1	1	1	1	1	1	1	1	1	1	1	1	0	0	0	0	0	0	0	0								
	White	1	1	1	1	1	1	1	1	1	1	1	1	1	1	1	1	1	1	1	1	1	1	1	1								
Red	Red (0)	0	0	0	0	0	0	0	0	0	0	0	0	0	0	0	0	0	0	0	0	0	0	0	0								
	Red (1)	0	0	0	0	0	0	0	1	0	0	0	0	0	0	0	0	0	0	0	0	0	0	0	0								
	Red (2)	0	0	0	0	0	0	1	0	0	0	0	0	0	0	0	0	0	0	0	0	0	0	0	0								
	Red (254)	1	1	1	1	1	1	1	0	0	0	0	0	0	0	0	0	0	0	0	0	0	0	0	0								
	Red (255)	1	1	1	1	1	1	1	1	0	0	0	0	0	0	0	0	0	0	0	0	0	0	0	0								
Green	Green (0)	0	0	0	0	0	0	0	0	0	0	0	0	0	0	0	0	0	0	0	0	0	0	0	0								
	Green (1)	0	0	0	0	0	0	0	0	0	0	0	0	0	0	1	0	0	0	0	0	0	0	0									
	Green (2)	0	0	0	0	0	0	0	0	0	0	0	0	0	0	1	0	0	0	0	0	0	0	0									
	Green (254)	0	0	0	0	0	0	0	0	1	1	1	1	1	1	1	0	0	0	0	0	0	0	0									
	Green (255)	0	0	0	0	0	0	0	0	1	1	1	1	1	1	1	1	0	0	0	0	0	0	0									
Blue	Blue (0)	0	0	0	0	0	0	0	0	0	0	0	0	0	0	0	0	0	0	0	0	0	0	0	0								
	Blue (1)	0	0	0	0	0	0	0	0	0	0	0	0	0	0	0	0	0	0	0	0	0	0	0	1								
	Blue (2)	0	0	0	0	0	0	0	0	0	0	0	0	0	0	0	0	0	0	0	0	0	0	1	0								
	Blue (254)	0	0	0	0	0	0	0	0	0	0	0	0	0	0	0	0	1	1	1	1	1	1	1	0								
	Blue (255)	0	0	0	0	0	0	0	0	0	0	0	0	0	0	0	0	1	1	1	1	1	1	1	1								

[Note]

1) Definition of gray scale:

Color (n): n indicates gray scale level; higher n means brighter level.

2) Data: 1-High, 0-Low.

7.2 Pixel Mapping

D(1, 1)	D(2, 1)	---	D(X, 1)	---	D(1023, 1)	D(1024, 1)
D(1, 2)	D(2, 2)	---	D(X, 2)	---	D(1023, 2)	D(1024, 2)
		+		+		
D(1, Y)	D(2, Y)	---	D(X, Y)	---	D(1023, Y)	D(1024, Y)
		+		+		
D(1,767)	D(2,767)	---	D(X,767)	---	D(1023,767)	D(1024,767))
D(1,768)	D(2,768)	---	D(X,768)	---	D(1023,768)	D(1024,768)

8. BLOCK DIAGRAM

8.1 TFT-LCD Module

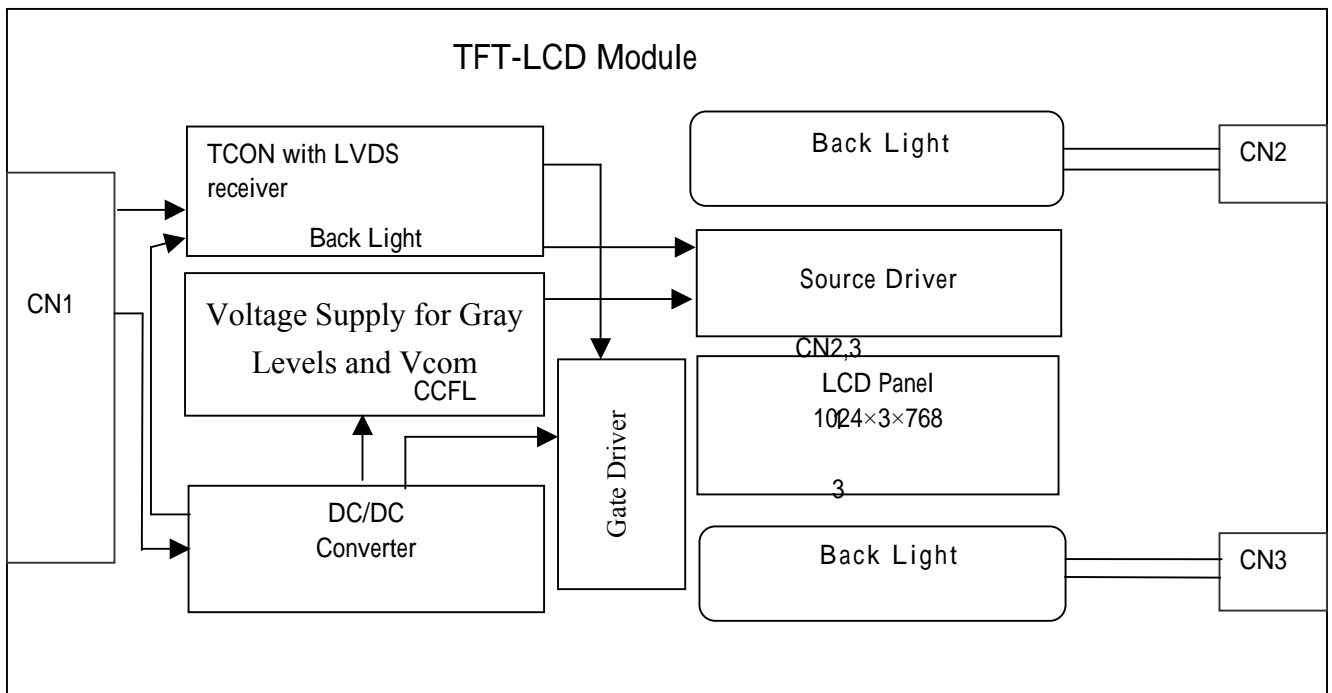

8.2 B/L Unit

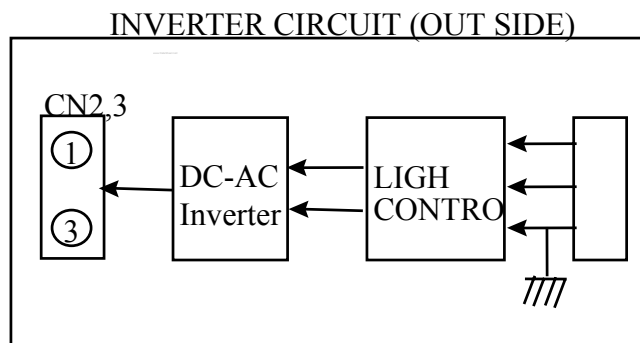
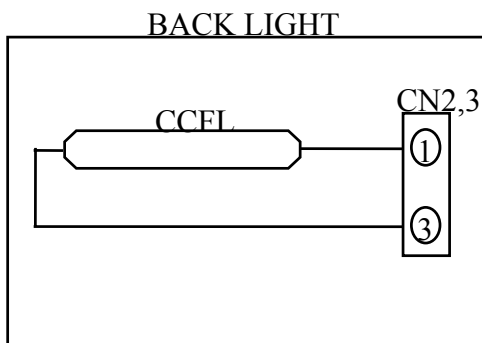

9. MECHANICAL SPECIFICATION

9.1 Front side (Tolerance is $\pm 0.5\text{mm}$ unless noted)

[Unit: mm]

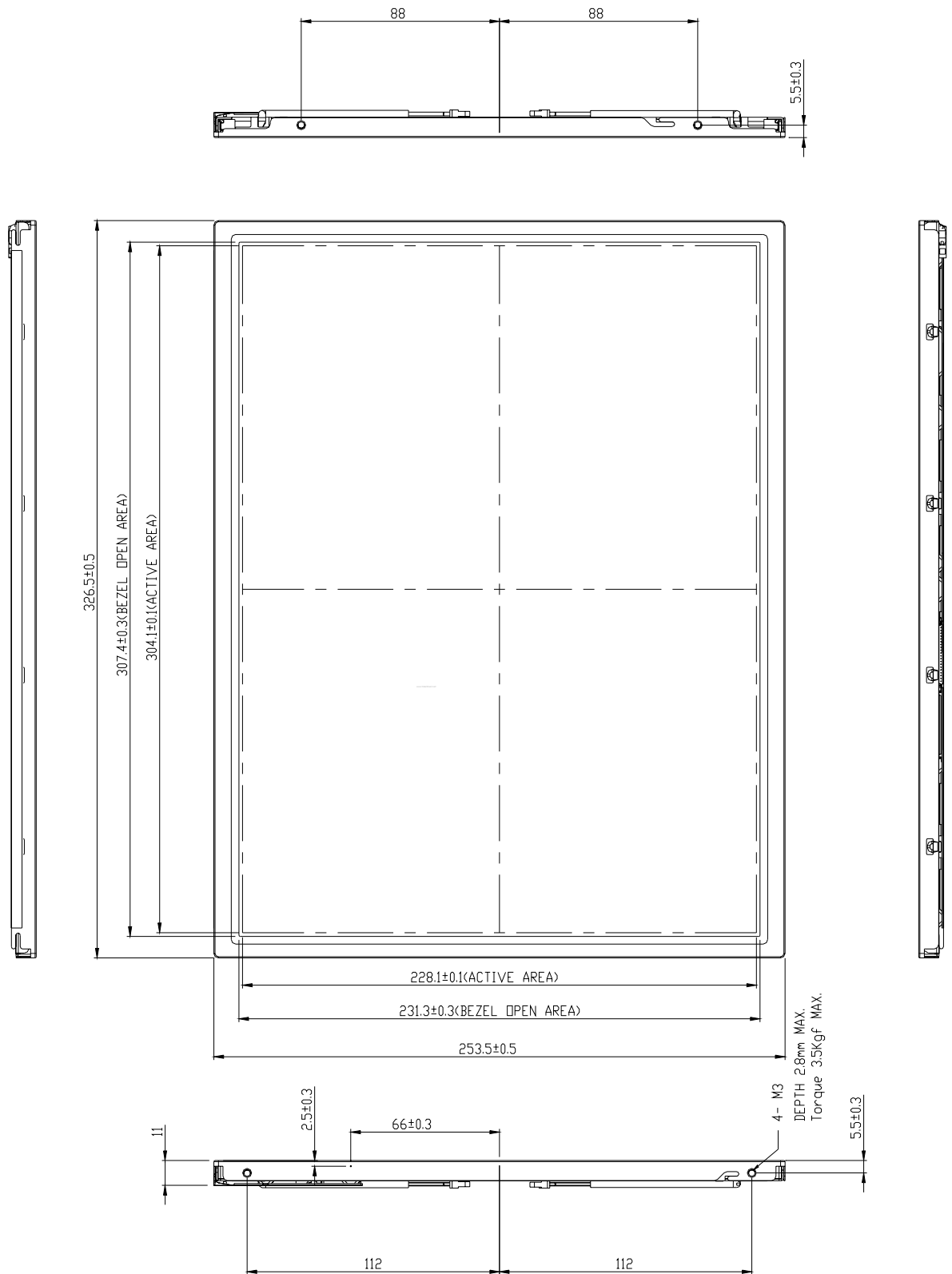

9.2 Rear side (Tolerance is $\pm 0.5\text{mm}$ unless noted)

[Unit: mm]

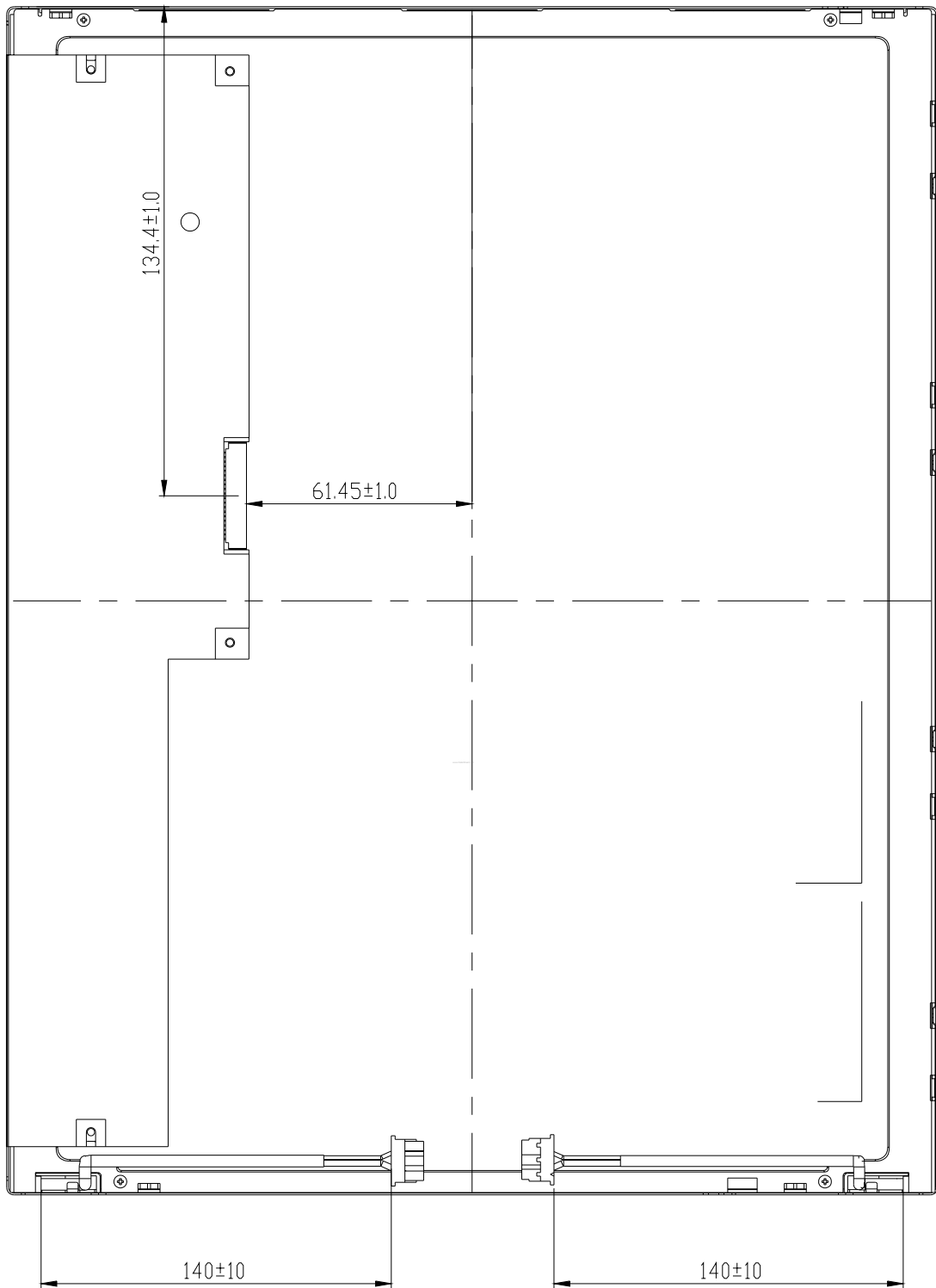

10.OPTICAL CHARACTERISTICS

Ta = 25°C, VCC=3.3V

ITEM	SYMBOL	CONDITION	MIN.	TYP.	MAX.	UNIT	REMARK
Contrast (CEN)	CR	$\theta = 0^\circ$	400	500	--	--	*1)
Luminance (CEN)	L	$\theta = 0^\circ$	200	250	--	cd/m ²	*2)
9P Luminance (AVG)	L	$\theta = 0^\circ$	180	225	--	cd/m ²	*2)
9P Uniformity	ΔL	$\theta = 0^\circ$	75	80	--	%	*2)
Response Time	T _r	$\theta = 0^\circ$	--	5	10	ms	*4)
	T _f	$\theta = 0^\circ$	--	11	20	ms	
Cross talk (crosstalk)	CMR	$\theta = 0^\circ$	--	--	1	%	*6)
Image sticking	T _{is}	2 hours	0	--	2	s	*5)
View angle	Horizontal	CR 5	-70~70	-85~85	--	Deg.	*3)
	Vertical		θ	-70~70	-85~85	--	
View angle	Horizontal	CR 10	-55~55	-70~70	--	Deg.	*3)
	Vertical		θ	-45~50	-60~65 (TN Type)	--	
Color Coordinates	White	X	0.283	0.313	0.343	--	--
		Y	0.299	0.329	0.359		
	Red	X	0.613	0.643	0.673		
		Y	0.305	0.335	0.365		
Green	X	0.270	0.300	0.330			
	Y	0.555	0.585	0.615			
Blue	X	0.113	0.143	0.173			
	Y	0.049	0.079	0.109			

[Note]

These items are measured using BM-5A (TOPCON) under the dark room condition (no ambient light).

Measurement Condition: IL=8.0±0.1mA

Inverter: ConverTek CVT010330BI31402, Frequency=50kHz.

Definition of these measurement items is as follows:

*1) Definition of Contrast Ratio

CR=ON (White) Luminance/OFF (Black) Luminance

Fulfil TCO99 1.5.2 Luminance uniformity spec.

*2) Definition of Luminance and Luminance uniformity

Central luminance: The white luminance is measured at the center position "5" on the screen, see Fig.1 below.

9P Luminance (AVG): The white luminance is measured at measuring points 1 to 9, see Fig.1 below.

9P Uniformity: $\Delta L = (L_{MIN} / L_{MAX}) \times 100\%$

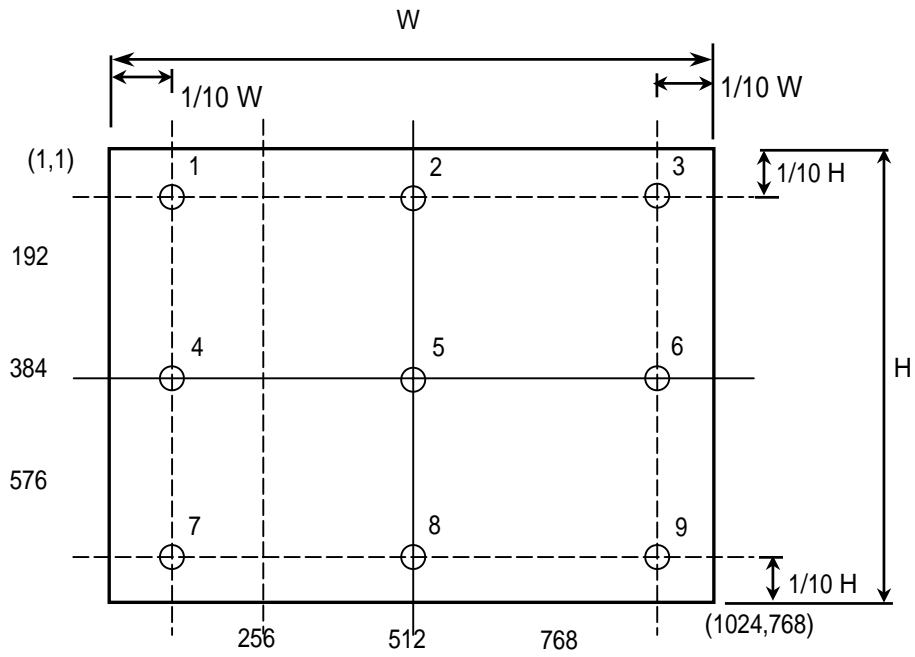
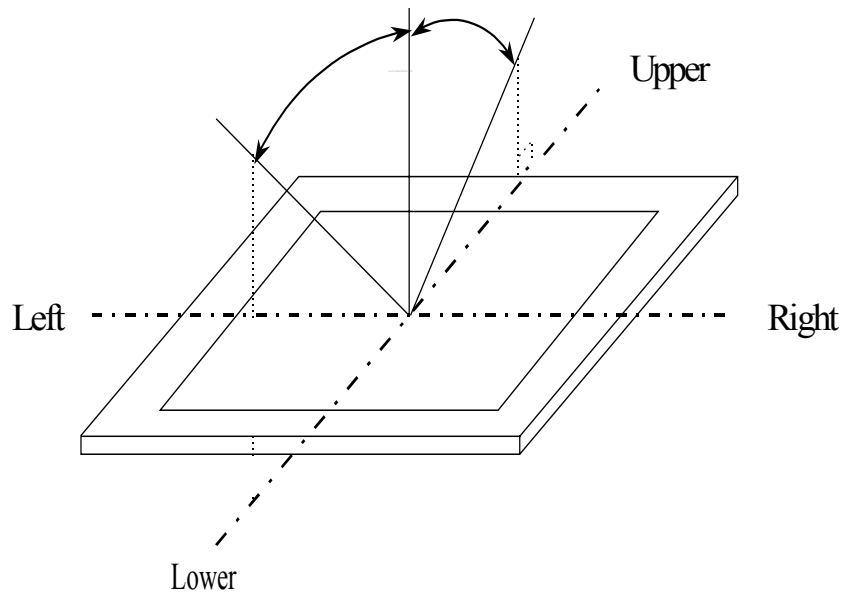

Figure 1. Measurement positions

*3) Definition of Viewing Angle(,)



*4) Definition of Response Time

Change the module frame to Black/white pattern and use Westar TDR-100 to measure t_r and t_f under 25 °C room temperature.

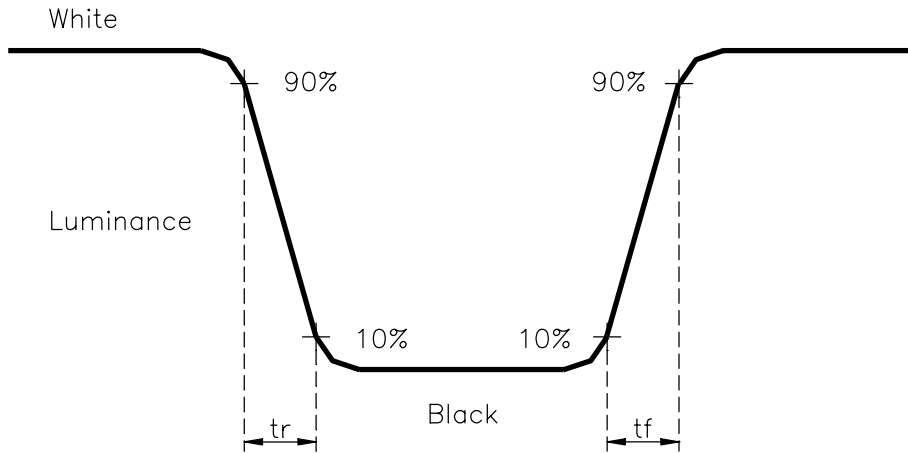

*5) Image sticking:

Continuously display the test pattern shown in the figure below for two-hours. Then display a completely white screen. The previous image shall not persist more than two seconds at 25 °C.



(“BLACK” back ground with “WHITE” R’s)

*6) Cross talk Modulation Ratio:

CRM= MAX((| (LB1-LA)/LC |)×100), (| (LB2-LA)/LC|)×100)
 LA : Pattern A (Half-Tone pattern) measurement point luminance
 LB1、 LB2 : Pattern B1、 B2 measurement point luminance
 LC : Pattern C (white pattern) measurement point luminance

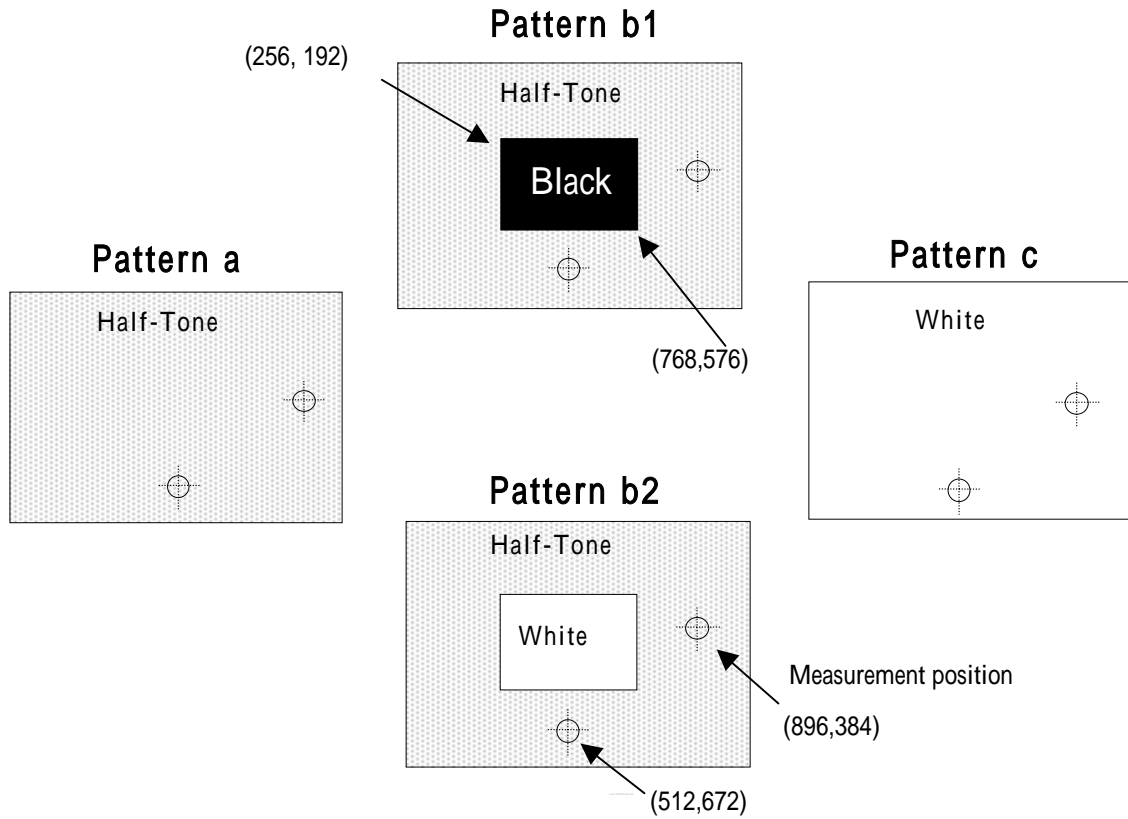

11.RELIABILITY TEST CONDITIONS

(1) Temperature and Humidity

TEST ITEMS	CONDITIONS
High Temperature High Humidity Operation	40 ; 95%RH; 240hrs (No condensation)
High Temperature High Humidity Storage	60 ; 90%RH; 240hrs (No condensation)
High Temperature Operation	50 ; 240hrs
High Temperature Storage	60 ; 240hrs
Low Temperature Operation	0 ; 240hrs
Low Temperature Storage	-20 ; 240hrs
Thermal Shock	Between -20 (1hr) and 60 (1hr); 100 Cycles

(2) Shock & Vibration

ITEMS	CONDITIONS
Shock (Non-Operation)	Shock level: 1470m/s ² (150G) Waveform: half sinusoidal wave, 2ms Number of shocks: one shock input in each direction of three mutually perpendicular axes for a total of six shock inputs
Vibration (Non-Operation)	Vibration level: 9.8m/s ² (1.0G) zero to peak Waveform: sinusoidal Frequency range: 5 to 500 Hz Frequency sweep rate: 0.5 octave/min Duration: one sweep from 5 to 500Hz in each of three mutually perpendicular axis(each x,y,z axis: 1 hour, total 3 hours)

(3)ESD test

Test Item	Test statements
Connector	200 pF , 0 Ω , ±250 V By using contact-mode to discharge each pin one time and then check the module frame.
module	1. Under test conditions, by using air-mode to discharge each test point 25 times continuously and then check the module frame. 2. Under test conditions, by using contact-mode to discharge each test point of panel frame 25 times continuously and then check the module frame.

(4) Judgment standard

The judgment of the above test should be made as follow:

Pass: Normal display image with no obvious non-uniformity and no line defect.

Partial transformation of the module parts should be ignored.

Fail: No display image, obvious non-uniformity, or line defects.

12. HANDLING PRECAUTIONS FOR TFT-LCD MODULE

Please pay attention to the followings in handling- TFT-LCD products;

12.1 ASSEMBLY PRECAUTION

- (1) Please use the mounting hole on the module side in installing and do not beading or wrenching LCD in assembling. And please do not drop, bend or twist LCD module in handling.
- (2) Please design display housing in accordance with the following guide lines.
 - Housing case must be destined carefully so as not to put stresses on LCD all sides and not to wrench module. The stresses may cause non-uniformity even if there is no non-uniformity statically.
 - Keep sufficient clearance between LCD module back surface and housing when the LCD module is mounted. Approximately 1.0 mm of the clearance in the design is recommended taking into account the tolerance of LCD module thickness and mounting structure height on the housing.
 - When some parts, such as, FPC cable and ferrite plate, are installed underneath the LCD module, still sufficient clearance is required, such as 0.5mm. This clearance is, especially, to be reconsidered when the additional parts are implemented for EMI countermeasure.
 - Design the inverter location and connector position carefully so as not to give stress to lamp cable, or not to interface the LCD module by the lamp cable.
 - Keep sufficient clearance between LCD module and the others parts, such as inverter and speaker so as not to interface the LCD module. Approximately 1.0mm of the clearance in the design is recommended.
- (3) Please do not push or scratch LCD panel surface with any-thing hard. And do not soil LCD panel surface by touching with bare hands. (Polarizer film, surface of LCD panel is easy to be flawed.)
- (4) Please do not press any parts on the rear side such as source TCP, gate TCP, control circuit board and FPCs during handling LCD module. If pressing rear part is unavoidable, handle the LCD module with care not to damage them.
- (5) Please wipe out LCD panel surface with absorbent cotton or soft cloth in case of it being soiled.
- (6) Please wipe out drops of adhesives like saliva and water on LCD panel surface immediately. They might damage to cause panel surface variation and color change.
- (7) Please do not take a LCD module to pieces and reconstruct it. Resolving and reconstructing modules may cause them not to work well.
- (8) Please do not touch metal frames with bare hands and soiled gloves. A color change of the metal frames can happen during a long preservation of soiled LCD modules.
- (9) Please pay attention to handling lead wire of backlight so that it is not tugged in connecting with inverter.

12.2 OPERATING PRECAUTIONS

- (1) Please be sure to turn off the power supply before connecting and disconnecting signal input cable.
- (2) Please do not change variable resistance settings in LCD module. They are adjusted to the most suitable value. If they are changed, it might happen LCD does not satisfy the characteristics specification.
- (3) Please consider that LCD backlight takes longer time to become stable of radiation characteristics in low temperature than in room temperature.
- (4) A condensation might happen on the surface and inside of LCD module in case of sudden change of ambient temperature.
- (5) Please pay attention to displaying the same pattern for very long time. Image might stick on LCD. If then, time going on can make LCD work well.
- (6) Please obey the same caution descriptions as ones that need to pay attention to ordinary electronic parts.

12.3 PRECAUTIONS WITH ELECTROSTATICS

- (1) This LCD module use CMOS-IC on circuit board and TFT-LCD panel, and so it is easy to be affected by electrostatics. Please be careful with electrostatics by the way of your body connecting to the ground and so on.
- (2) Please remove protection film very slowly on the surface of LCD module to prevent from electrostatics occurrence.

12.4 STORAGE PRECAUTIONS

- (1) When you store LCDs for a long time, it is recommended to keep the temperature between 0 ~40 without the exposure of sunlight and to keep the humidity less than 90%RH.
- (2) Please do not leave the LCDs in the environment of high humidity and high temperature such as 60 ~ 90%RH.
- (3) Please do not leave the LCDs in the environment of low temperature; below -20 .

12.5 SAFETY PRECAUTIONS

- (1) When you waste LCDs, it is recommended to crush damaged or unnecessary LCDs into pieces and wash them off with solvents such as acetone and ethanol, which should later be burned.
- (2) If any liquid leaks out of a damaged-glass cell and comes in contact with the hands, wash off thoroughly with soap and water.

12.6 OTHERS

- (1) A strong incident light into LCD panel might cause display characteristics' changing inferior because of polarizer film, color filter, and other materials becoming inferior. Please do not expose LCD module direct sunlight and strong UV rays.
- (2) Please pay attention to a panel side of LCD module not to contact with other materials in preserving it alone.
- (3) For the packaging box, please pay attention to the followings:
 - Packaging box and inner case for LCD are designed to protect the LCDs from the damage or scratching during transportation. Please do not open except picking LCDs up from the box.
 - Please do not pile them up more than 3 boxes. (They are not designed so.) And please do not turn over.
 - Please handle packaging box with care not to give them sudden shock and vibrations. And also please do not throw them up.
 - Packing box and inner case for LCDs are made of cardboard. So please pay attention not to get them wet. (Such like keeping them in high humidity or wet place can occur getting them wet.)