



Chunghwa Picture Tubes, Ltd.

Technical Specification

CPT TFT-LCD

CLAA150XP07FQ

APPROVED BY	CHECKED BY	PREPARED BY

Prepared by : Design General Division

CHUNGHWA PICTUER TUBES, LTD.

1127 Hopin Rd., Padeh, Taoyuan, Taiwan 334, R.O.C.
TEL: +886-3-3675151 FAX: +886-3-377-3001

Doc. No:	CLAA150XP07FQ-A	Issue Date:	2006-09-11
----------	------------------------	-------------	------------

Title : CLAA150XP07FQ Technical Specification

Modification Record List

暫行

NO.	Issue Date	Modification Index	Modifier
1	2006-09-11	Temporary specification for 150XP07FQ	PE
2			
3			
4			
5			
6			
7			
8			
9			
10			
11			

Title : CLAA150XP07FQ Technical Specification

Table Of Content

項次	Table of Content	Note
1	OVERVIEW	4
2	ABSOLUTE MAXIMUM RATINGS	5
3	ELECTRICAL CHARACTERISTICS	7
4	INTERFACE PIN CONNECTION	13
5	INTERFACE TIMING	14
6	BLOCK DIAGRAM	19
7	MECHANICAL SPECIFICATION	21
8	OPTICAL CHARACTERISTICS	22
9	RELIABILITY TEST CONDITIONS	27
10	HANDLING PRECAUTIONS FOR TFT-LCD MODULE	29
11	PACKING FORM	32
12	SAFETY	33

Title : CLAA150XP07FQ Technical Specification

1. OVERVIEW

CLAA150XP01FQ is 15”(38.1cm) color TFT-LCD (Thin Film Transistor Liquid Crystal Display) module composed of LCD panel, LVDS driver ICs, control circuit and backlight(CCFL, 4 tubes). By applying 8 bit digital data, 1024×768, driven by 3.3 voltages, 16.2M-color images are displayed on the 15” diagonal screen. The module structure is fixed by iron frame, without the inverter for the backlight. Interface of data and control signals is typ.General specification are summarized in the following table:

ITEM	SPECIFICATION
Display Area (mm)	304.1(H)x228.1(V) (15.0-inch diagonal)
Number of Pixels	1024x3(H) × 768(V)
Pixel Pitch (mm)	0.297(H) × 0.297(V)
Color Pixel Arrangement	RGB vertical stripe
Display Mode	Normally White, TN
Number of Colors	16.2M (6bits+FRC)
Optimum Viewing Angle	6 o'clock
Brightness (cd/m ²)	450cd/m ² (Typ.)(center, 6.5mA)
Viewing Angle	(140/125) (Typ.)
Response time	(8ms)
Surface Treatment, Haze	Anti-glare
Color Saturation	65%
Module Size (mm)	326.5(W) × 253.5(H) × 11.0(D) (Typ.)
Power consumption	(16.64+1.8) Watt (Typ)
Module Weight (g)	1300 (Typ.)
Backlight Unit	CCFL, 4 tubes (top × 1/bottom ×1), Edge light

The LCD Products listed on this document are not suitable for use of aerospace equipment, submarine cables, and nuclear reactor control system and life support systems. If customers intend to use these LCD products for above application or not listed in "Standard" as follows, please contact our sales in advance.

Standard: Computer, Office equipment, Communication equipment, Test and Measurement equipment, Machine tool, Industrial robot, Audio and Visual equipment, Other consumer products.

Title : CLAA150XP07FQ Technical Specification

2. ABSOLUTE MAXIMUM RATINGS

The following are max. values which, if exceeded, may cause faulty operation or damage to the unit.

ITEM	SYMBOL	MIN.	MAX.	UNIT	Remark
Power Supply Voltage For LCD	VCC	--	4.0	V	--
IDDD Rush Current	IRUSHd	--	(4.0)	A	*1)
Lamp Voltage	VL	495	605	Vrms	*2)
Lamp Current	IL	3.5	8	mArms	*2)
Lamp Frequency	FL	40	80	kHz	*2) *3)
Operation Temperature (Surrounding)	Top	0	50	°C	*4). 5). 6). 7)
Storage Temperature	Tstg	-20	60	°C	*4). 5). 6)
Delayed Discharge Time	TD	--	1	sec	*8)

***1) Inrush Measurement Condition**

The rising time of VCC is 550 μsec (measured conditions are described below).

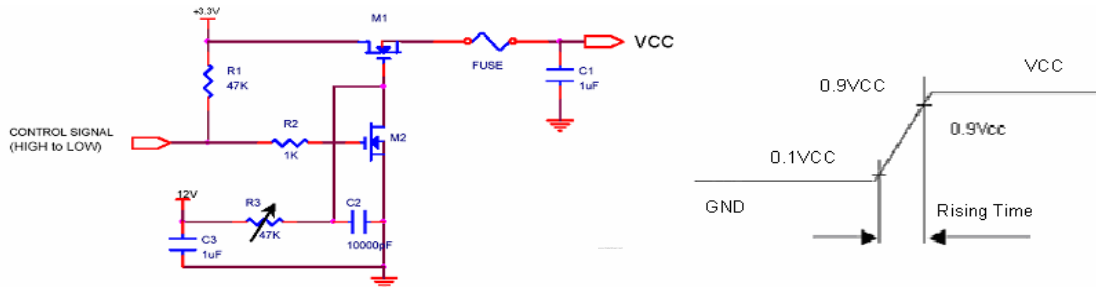

***2) These are properties of single lamp(without backlight).**

a. Lamp life-time relate to the lamp current, please operate following statement Back light system at page 7.

b. When lamp current over the definition of absolute max. value , life-time of the product will decay rapidly or operate unusual.

***3) The frequency range will not affect to lamp life and reliability characteristics.**

a. Electrical and optical characteristics will display well at 40~60 kHz frequency.

b. It would not damage the lifetime and reliability of the panel at 40~80 kHz frequency.

***4) The relative temperature and humidity range are as below sketch, 90%RHMax. (Ta ≤ 40°C)**

*5) The maximum wet bulb temperature ≤ 39°C (Ta > 40°C) and without dewing.

*6) If you use the product in a environment which over the definition of temperature and humidity, it will concern for visual quality.

*7) If you operated the product in normal temperature range, the center surface of panel should be under 60°C.

*8) Delay lighting testing needs the volt above start voltage Vrms. Before the procedure tube needs typical lighting for 1 min. and stay in the temperature 25±2 °C for 24 hours and then testing in the same condition in dark room.

Humidity ≤ 85%RH without condensation. Relative Humidity ≤ 90% (Ta ≤ 40°C)

Wet Bulb Temperature ≤ 39°C (Ta ≥ 40°C)

Title : CLAA150XP07FQ Technical Specification

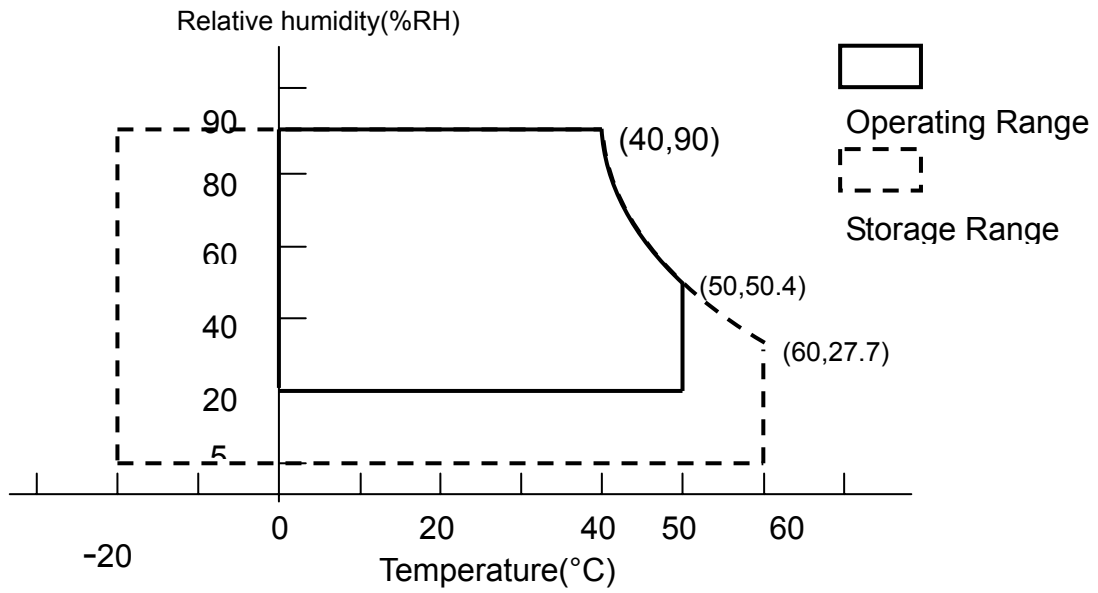

Title : CLAA150XP07FQ Technical Specification

3. ELECTRICAL CHARACTERISTICS

(1) TFT-LCD

Ta=25°C

ITEM	SYMBOL	MIN	TYP	MAX	UNIT	REMARK
Power Supply Voltage for LCD	VCC	3.0	3.3	3.6	V	*1)
Power Supply Current for LCD	ICC	--	(450)	(600)	mA	*2)
Permissible Ripple Voltage for Logic	VRPd	--	--	100	mVp-p	Vin=+3.3V
Differential Resistance	Zm	(70)	100	110	Ω	*3)

[Note]

*1)Power 、 data sequence

(0.5 ms < t1 ≤ 10ms)

(500 ms ≤ t4)

0 ms < t2 ≤ 50 ms

200 ms ≤ t5

0 ms < t3 ≤ 50 ms

200 ms ≤ t6

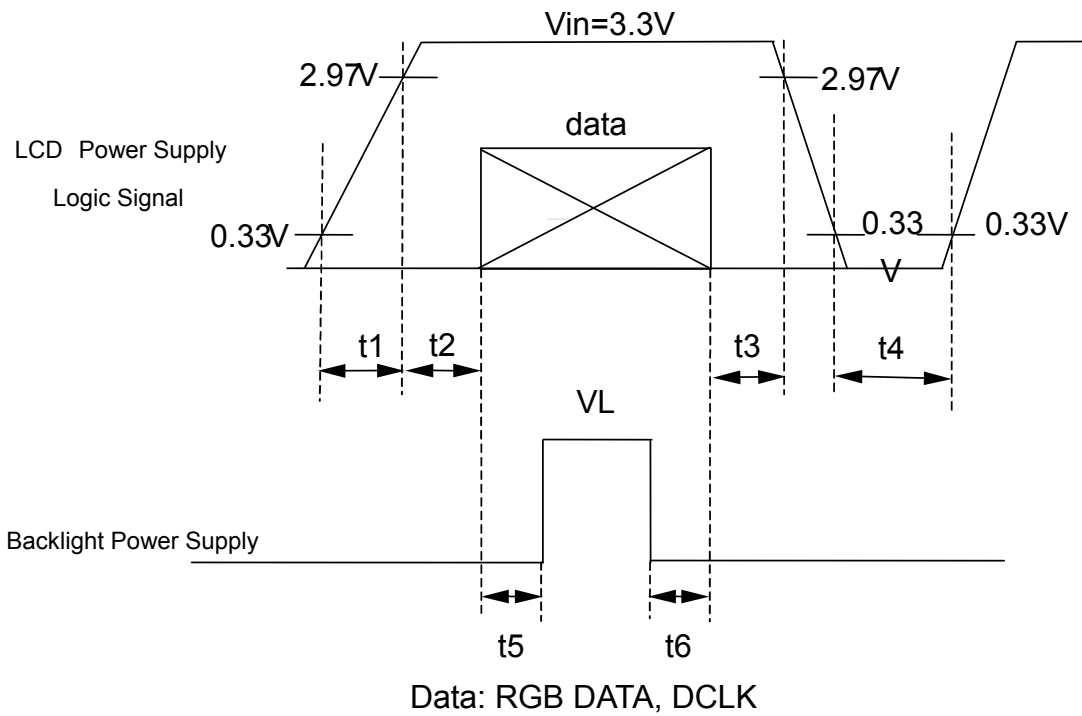

Title : CLAA150XP07FQ Technical Specification

VCC-dip State :

- 1) When $2.7\text{ V} \leq VCC < 3.0\text{V}$, $t_d \leq 10\text{ ms}$
- 2) When $VCC < 2.7\text{V}$, it will reset the power, VCC dip conditions should follow the VCC-power sequence condition.

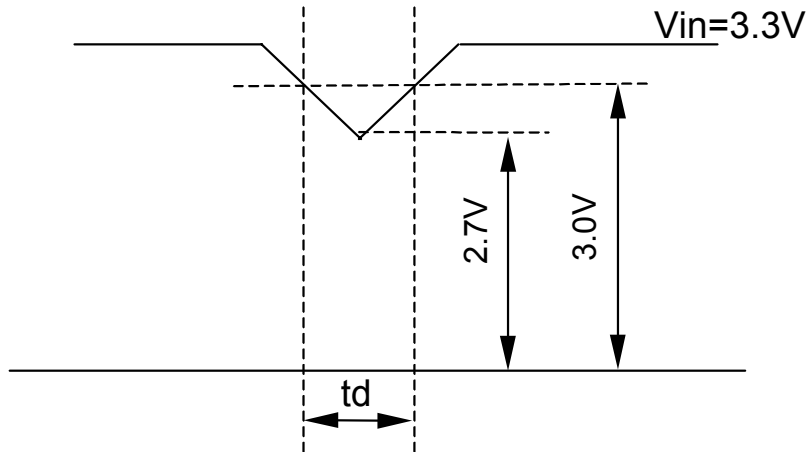

Title : CLAA150XP07FQ Technical Specification

*2) 1. Typical value is measured when displaying horizontal gray scale line pattern:

0~255 gray level, 768 line mode

VCC= +3.3 V , f_{CLK}=65 MHz

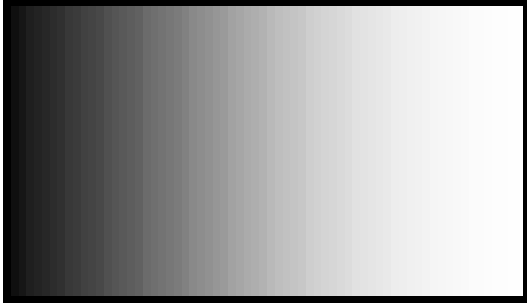

2. Max. value:

768 line mode , VCC= +3.3 V , f_{CLK}=65 MHz

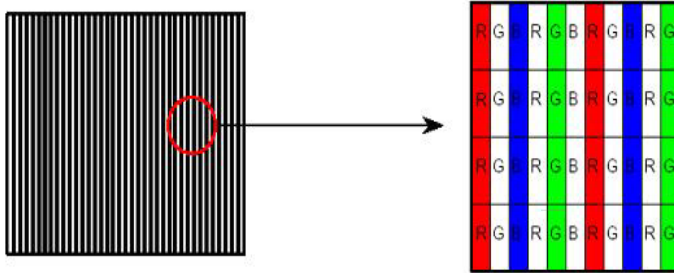

*3) LVDS Signal definition :

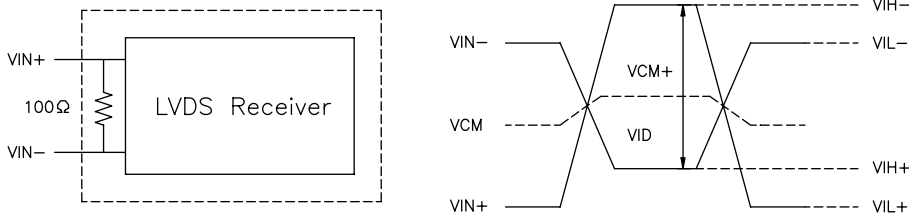

$$VID = VIN_+ - VIN_-$$

$$\Delta VCM = | VCM_+ - VCM_- | ,$$

$$\Delta VID = | VID_+ - VID_- | ,$$

$$VID_+ = | VIH_+ - VIH_- | ,$$

$$VID_- = | VIL_+ - VIL_- | ,$$

$$VCM = (VIN_+ + VIN_-) / 2 ,$$

$$VCM_+ = (VIH_+ + VIH_-) / 2 ,$$

$$VCM_- = (VIL_+ + VIL_-) / 2$$

VIN+ : Positive differential DATA & CLK Input

VIN- : Negative differential DATA & CLK Input

Title : CLAA150XP07FQ Technical Specification

(2) Backlight

(a) Electrical Characteristics

Ta=25°C

ITEM	SYMBOL	MIN	TYP	MAX	UNIT	REMARK
Lamp Voltage	VL	576	640	704	Vrms	*1) ; IL=6.5mA
Lamp Standard Current	IL	6.0	6.5	7.0	mArms	*2)
Inverter Frequency	FI	40		80	kHz	*1) *3) *4)
Start up Lamp Voltage	VS		—	950	Vrms	Ta=25°C *1) *5)
			—	1100	Vrms	Ta=0°C *1) *5)

(b) Lamp Life

ITEM	IL @3.0 mA	IL @6.5 mA	IL @8.0 mA	UNIT	REMARK
Lamp Life Time	--	Min. 50,000	Min. 40,000	hr	Continuous Operation*6)
Turn-on and Turn-off Operation	--	Min. 100,000	--	time	Continuous Operation*7)

[Note]

If the waveform of light up-driving is asymmetric, the distribution of mercury inside the lamp tube will become unequally or will deplete the Ar gas in it. Then it may cause the abnormal phenomenon of lighting-up. Therefore, designers have to try their best to fulfill the conditions under the inverter designing-stage as below:

- The degrees of unbalance : < 10%

Title : CLAA150XP07FQ Technical Specification

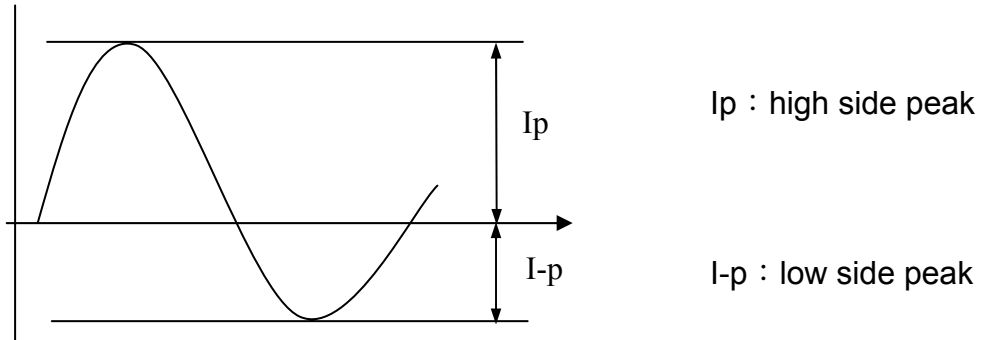

A : The degrees of unbalance = $| I_p - I-p | / I_{rms} \times 100$ (%)

B : The ratio of wave height = I_p (or $I-p$) / I_{rms}

- The ratio of wave height : $< \sqrt{2} \pm 10\%$

Title : CLAA150XP07FQ Technical Specification

- *1) These are properties of single lamp(without backlight).
- *2) Lamp Current measurement method (The current meter is inserted in cold line)

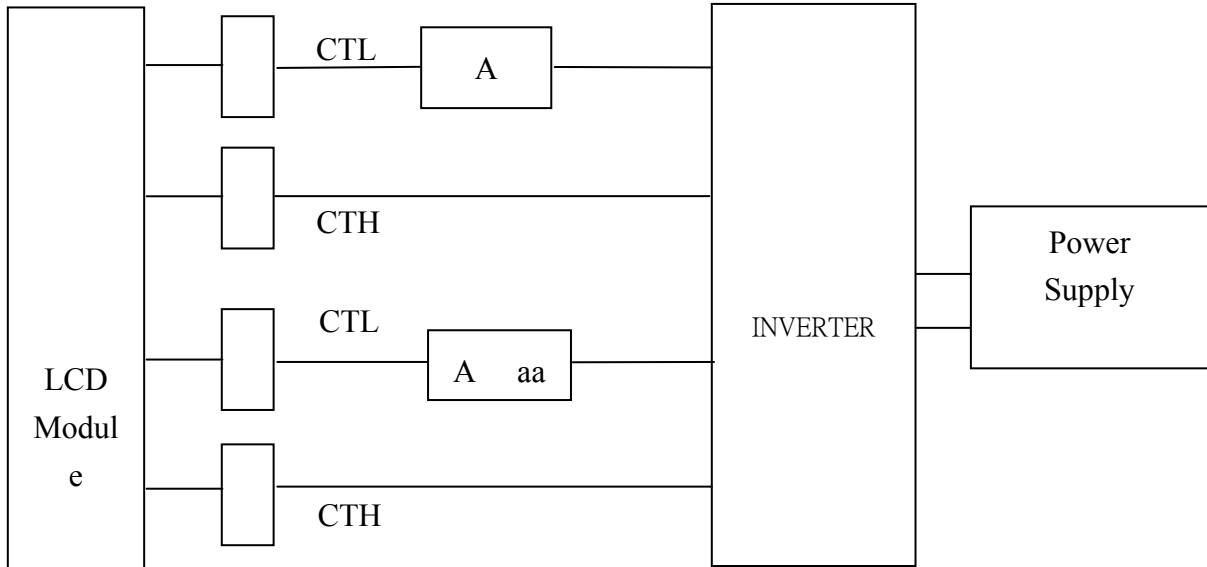

- *3) The frequency range can be kept within +/- 10% range of electrical and optical characteristics.
- *4) Lamp frequency of inverter may produce interference with horizontal synchronous frequency, and this may cause horizontal beat on the display. Therefore, please adjust lamp frequency, and keep inverter as far from module as possible or use electronic shielding between inverter and module to avoid the interference.
- *5) The maximum value of starting lamp voltage is defined as the probably biggest value of starting lamp voltage, hence the design of starting lamp voltage for inverter must be equal to or higher than maximum starting lamp voltage.
- *6) Definition of the lamp life time :
Luminance reduced to 50% of initial value.
When lamp current over 8.0mA, lamp life time will drop rapidly. If over 8.0mA, it will come up safety issue. But if it lower than 3.5mA, the lamp will be damaged.
- *7) The condition of Turn-on and Turn-off operation is as below:
 - a. Lamp current is 8.0mA. Ta=25±5 °C .
 - b. Frequency is (10) sec.(on)/(10) sec.(off)
 - c. Repeat it for 100 thousand times
 - d. The lamp life time still match the definition*6)

Title : CLAA150XP07FQ Technical Specification

4. Connector Interface PIN & Function

(1) CN1

Outlet connector: **MSB240420 (STM) or equivalent**

Plug connector: **DF14-20S-1.25C (Hirose) or equivalent**

PIN #	SYMBOL	FUNCTION
1	VCC	+3.3V Power Supply
2	VCC	+3.3V Power Supply
3	GND	GND
4	GND	GND
5	RXIN0-	Negative LVDS Differential Data Input
6	RXIN0+	Positive LVDS Differential Data Input
7	GND	GND
8	RXIN1-	Negative LVDS Differential Data Input
9	RXIN1+	Positive LVDS Differential Data Input
10	GND	GND
11	RXIN2-	Negative LVDS Differential Data Input
12	RXIN2+	Positive LVDS Differential Data Input
13	GND	GND
14	RXCLK	Negative LVDS Differential Clock Input
15	RXCLK	Positive LVDS Differential Clock Input
16	GND	GND
17	RXIN3-	Negative LVDS Differential Data Input
18	RXIN3+	Positive LVDS Differential Data Input
19	GND	GND
20	NC	Reserved

- 1) Please keep the NC Pin and don't connect it to GND or other signals.
- 2) GND Pin must connect to the ground, don't let it be a vacant pin.

(2) CN2,3,4,5(BACKLIGHT)

Backlight-side connector: **BHR-02VS-1 (JST)**

Inverter-side connector: **SM03B-BDS-1 (JST)**

CN2,3,4,5

PIN #	SYMBOL	FUNCTION
1	CTH1~4	High Voltage
2	CTL1~4	Low Voltage

Title : CLAA150XP07FQ Technical Specification

5. INTERFACE TIMING

(1) Timing Characteristic

ITEM		SYMBOL	MIN.	TYP.	MAX.	UNIT		
LCD Timing	DCLK	Frequency	f_{CLK}	41	65	80	MHz	
		Cycle	t_{CLK}	12.5	15.3	24	ns	
	DENA	Horizontal	Vertical line rate	f_H	35.73	48.36	58.39	kHz
			Horizontal total time	t_H	1150	1344	1370	t_{CLK}
			Horioantal effective time	t_{HA}	--	1024	--	t_{CLK}
		Vertical	Horizontal blank time	t_{HB}	126	320	346	t_{CLK}
			Vertical frame Rate	Fr	45	60	75	Hz
			Vertical total time	t_V	794	806	860	t_H
			Vertical effective time	t_{VA}	--	768	--	t_H
			Vertical blank time	t_{VB}	26	38	92	t_H

(2) Timing Chart

a. Horizontal signal:

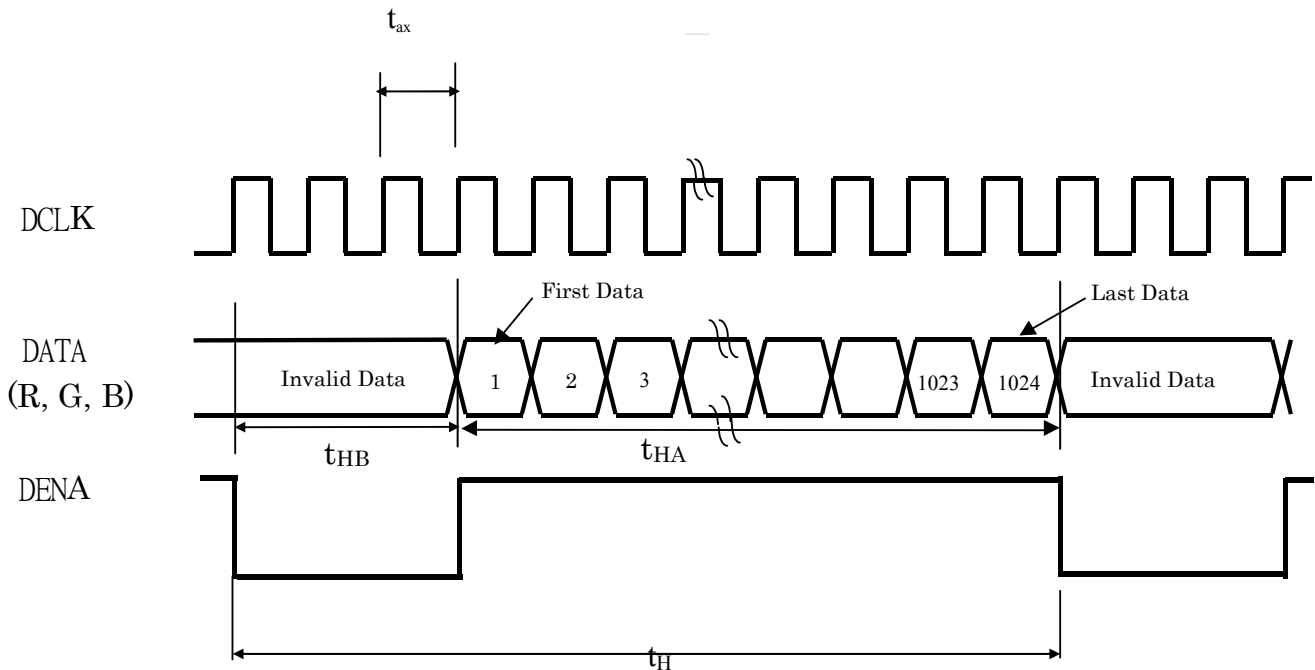

Title : CLAA150XP07FQ Technical Specification

b. Vertical signal:

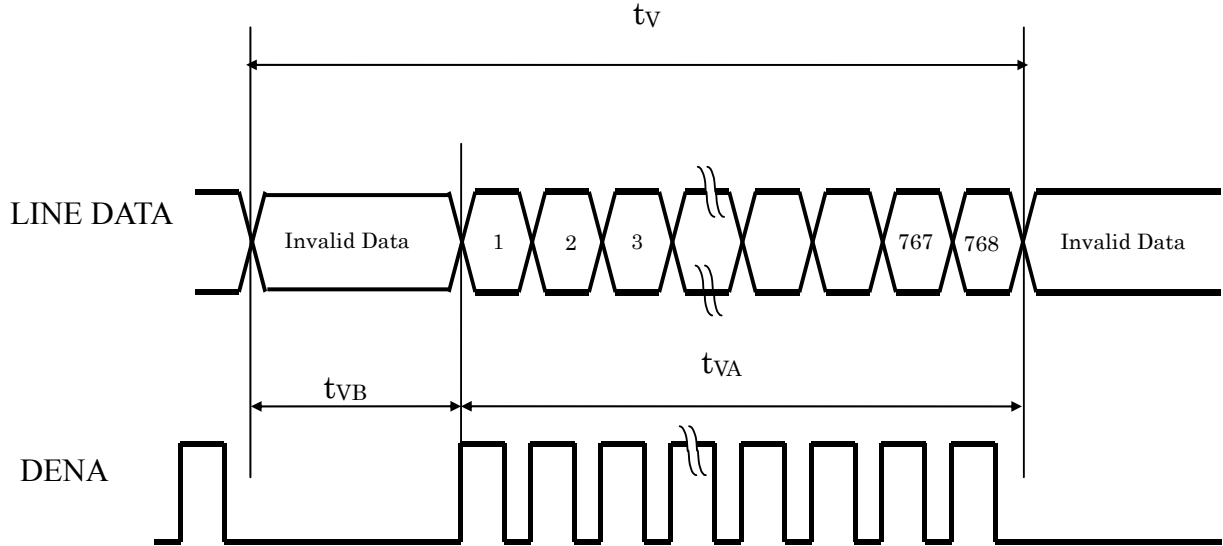

Title : CLAA150XP07FQ Technical Specification

(3) Data Mapping

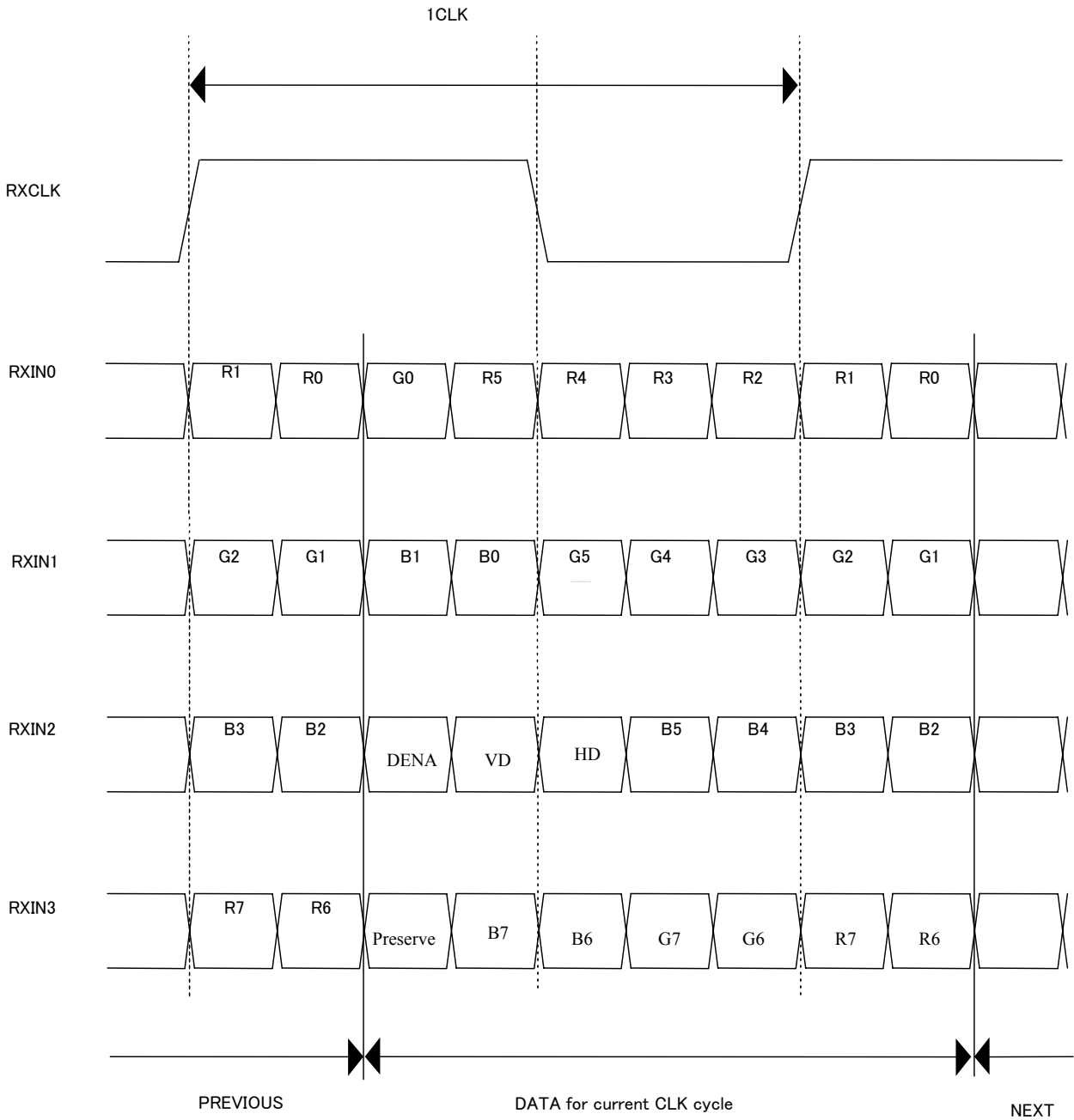

Title : CLAA150XP07FQ Technical Specification

(4) Color Data Assignment

Color	Input Data	MSB								LSB								MSB								LSB							
		R7	R6	R5	R4	R3	R2	R1	R0	G 7	G 6	G 5	G 4	G 3	G 2	G 1	G 0	B7	B6	B5	B4	B3	B2	B1	B0								
Basic Color	Black	0	0	0	0	0	0	0	0	0	0	0	0	0	0	0	0	0	0	0	0	0	0	0	0								
	Red	1	1	1	1	1	1	1	1	0	0	0	0	0	0	0	0	0	0	0	0	0	0	0	0								
	Green	0	0	0	0	0	0	0	0	1	1	1	1	1	1	1	1	0	0	0	0	0	0	0	0								
	Blue	0	0	0	0	0	0	0	0	0	0	0	0	0	0	0	0	1	1	1	1	1	1	1	1								
	Cyan	0	0	0	0	0	0	0	0	1	1	1	1	1	1	1	1	1	1	1	1	1	1	1	1								
	Magenta	1	1	1	1	1	1	1	1	0	0	0	0	0	0	0	0	1	1	1	1	1	1	1	1								
	Yellow	1	1	1	1	1	1	1	1	1	1	1	1	1	1	1	1	0	0	0	0	0	0	0	0								
	White	1	1	1	1	1	1	1	1	1	1	1	1	1	1	1	1	1	1	1	1	1	1	1	1								
Red	Red (0)	0	0	0	0	0	0	0	0	0	0	0	0	0	0	0	0	0	0	0	0	0	0	0	0								
	Red (1)	0	0	0	0	0	0	0	1	0	0	0	0	0	0	0	0	0	0	0	0	0	0	0	0								
	Red (2)	0	0	0	0	0	0	1	0	0	0	0	0	0	0	0	0	0	0	0	0	0	0	0	0								
	Red (254)	1	1	1	1	1	1	1	0	0	0	0	0	0	0	0	0	0	0	0	0	0	0	0	0								
	Red (255)	1	1	1	1	1	1	1	1	0	0	0	0	0	0	0	0	0	0	0	0	0	0	0	0								
Green	Green (0)	0	0	0	0	0	0	0	0	0	0	0	0	0	0	0	0	0	0	0	0	0	0	0	0								
	Green (1)	0	0	0	0	0	0	0	0	0	0	0	0	0	0	0	1	0	0	0	0	0	0	0	0								
	Green (2)	0	0	0	0	0	0	0	0	0	0	0	0	0	0	1	0	0	0	0	0	0	0	0	0								
	Green (254)	0	0	0	0	0	0	0	0	1	1	1	1	1	1	1	0	0	0	0	0	0	0	0	0								
	Green (255)	0	0	0	0	0	0	0	0	1	1	1	1	1	1	1	1	0	0	0	0	0	0	0	0								
Blue	Blue (0)	0	0	0	0	0	0	0	0	0	0	0	0	0	0	0	0	0	0	0	0	0	0	0	0								
	Blue (1)	0	0	0	0	0	0	0	0	0	0	0	0	0	0	0	0	0	0	0	0	0	0	0	1								
	Blue (2)	0	0	0	0	0	0	0	0	0	0	0	0	0	0	0	0	0	0	0	0	0	0	1	0								
	Blue (254)	0	0	0	0	0	0	0	0	0	0	0	0	0	0	0	0	1	1	1	1	1	1	1	0								
	Blue (255)	0	0	0	0	0	0	0	0	0	0	0	0	0	0	0	0	1	1	1	1	1	1	1	1								

Title : CLAA150XP07FQ Technical Specification

[Note]

1) Definition of gray scale:

Color (n): n indicates gray scale level; higher n means brighter level.

2) Data: 1-High, 0-Low.

Title : CLAA150XP07FQ Technical Specification

6. BLOCK DIAGRAM

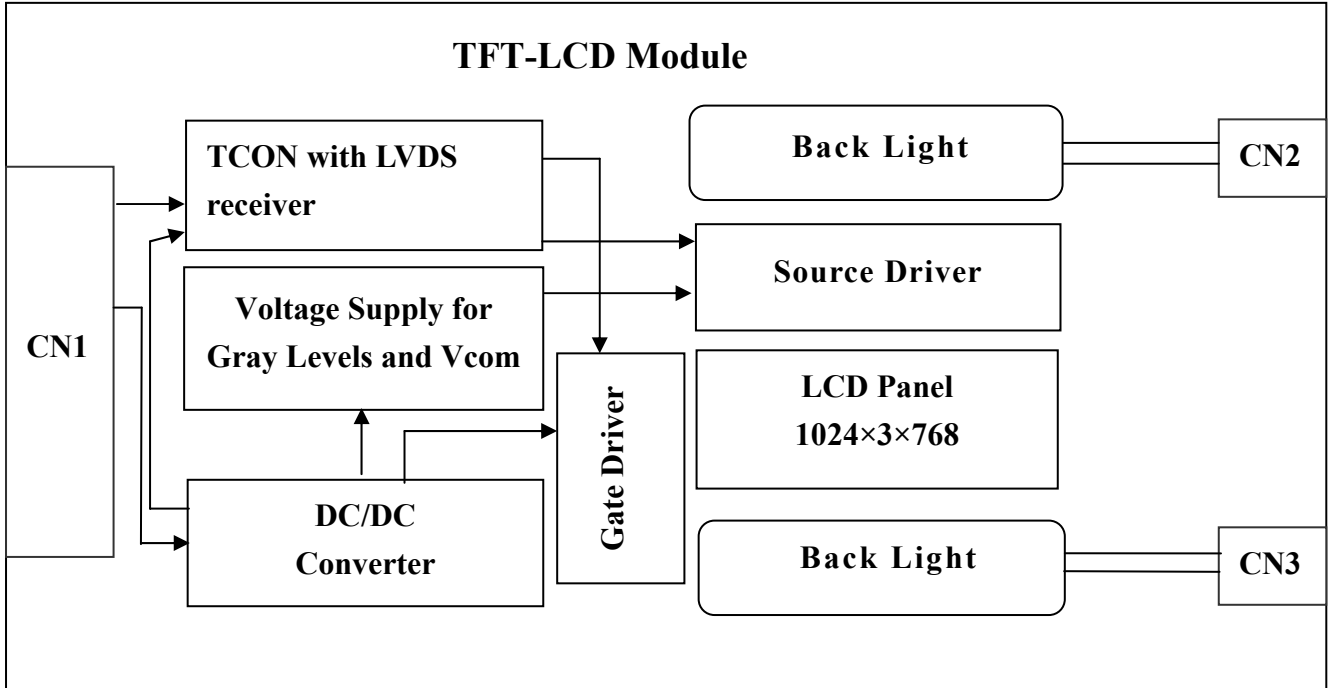

Title : CLAA150XP07FQ Technical Specification

7. MECHANICAL SPECIFICATION

(1) Front side (Tolerance is $\pm 0.5\text{mm}$ unless noted)

[Unit: mm]

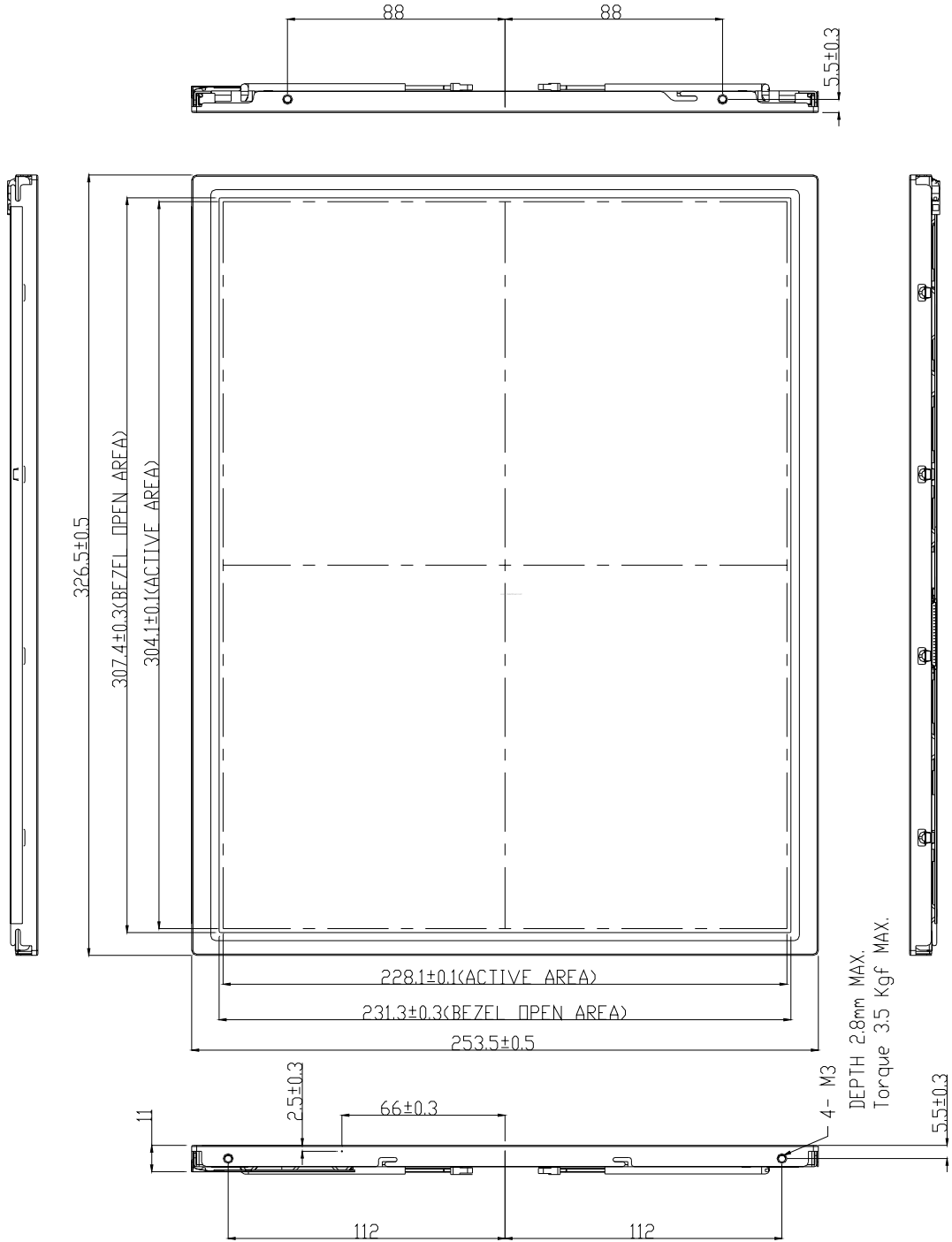

Title : CLAA150XP07FQ Technical Specification

(2) Rear side (Tolerance is $\pm 0.5\text{mm}$ unless noted)

[Unit: mm]

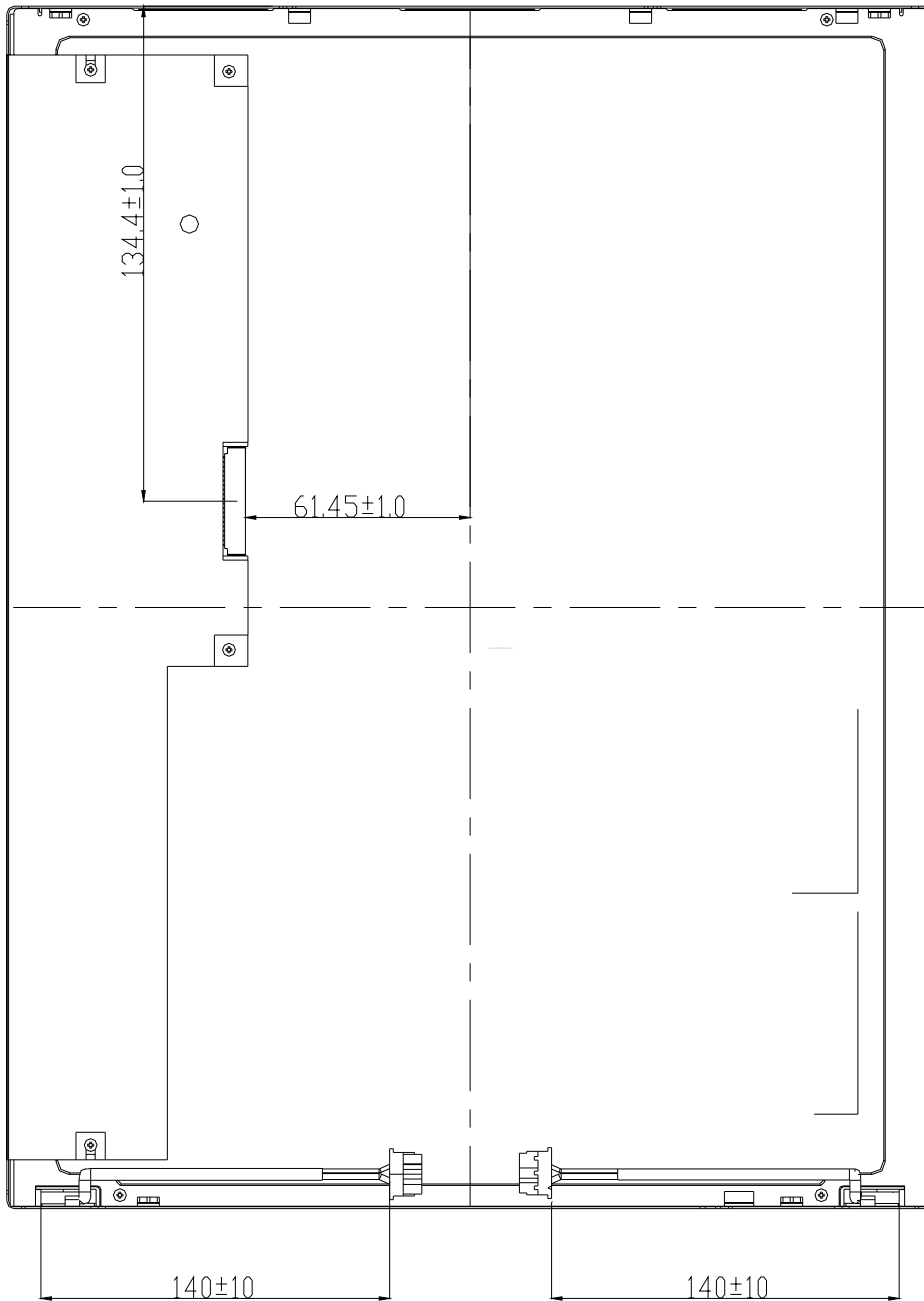

Title : CLAA150XP07FQ Technical Specification

8. OPTICAL CHARACTERISTICS

Ta = 25°C, VCC=3.3V

ITEM	SYMBOL	CONDITION	MIN.	TYP.	MAX.	UNIT	REMARK	
Contrast (CEN)	CR	$\theta = \phi = 0^\circ$	450	500	--	--	*1)	
Luminance (CEN)	L	$\theta = \phi = 0^\circ$	360	450	--	cd/m ²	*2)	
9P Luminance (AVG.)	L	$\theta = \phi = 0^\circ$	310	400	--	cd/m ²	*2)	
9P Uniformity (9P)	ΔL	$\theta = \phi = 0^\circ$	75	80	--	%	*2)	
Response Time	Tr	$\theta = \phi = 0^\circ$	--	(2)	(4)	ms	*4)	
	Tf	$\theta = \phi = 0^\circ$	--	(6)	(10)	ms		
Image sticking	Tis	(4) hours	--	--	(3)	s	*5)	
Cross talk	CMR	$\theta = \psi = 0^\circ$	--	--	1	%	*6)	
View angle	Horizontal	ϕ	CR \geq 5	(-60~60)	(-70~70)	--	Deg.	*3)
	Vertical	θ		(-50~55)	(-60~65)	--	Deg.	
	Horizontal	ϕ	CR \geq 10	(-75~75)	(-85~85)	--	Deg.	*3)
	Vertical	θ		(-75~75)	(-85~85)	--	Deg.	
Color Coordinates	White	X	$\theta = \phi = 0^\circ$	0.252	0.282	0.312	--	
		Y		0.263	0.293	0.323		
	Red	X		0.613	0.643	0.673		
		Y		0.305	0.335	0.365		
Green	X	0.267	0.297	0.327				
	Y	0.558	0.588	0.618				
Blue	X	0.112	0.142	0.172				
	Y	0.048	0.078	0.108				
Color Temperature	K	--	--	9600	--	K	--	
Gamma	γ	VESA	2.0	2.2	2.4	--	*7)	

[Note]

These items are measured using BM-5A (TOPCON) under the dark room condition (no ambient light).

Measurement Condition: IL=6.5 ± 0.1mA

Inverter: ConverTek, model: CVT010330BI31402.

Definition of these measurement items is as follows:

*1) Definition of Contrast Ratio

CR=ON (White) Luminance/OFF (Black) Luminance

Title : CLAA150XP07FQ Technical Specification

*2) Definition of Luminance and Luminance uniformity

Central luminance: The white luminance is measured at the center position "5" on the screen, see Fig.1 below.

9P Luminance (AVG): The white luminance is measured at measuring points 1 to 9, and take the average value, see Fig.1 below.

9P Uniformity: $\Delta L = (L_{MIN} / L_{MAX}) \times 100\%$

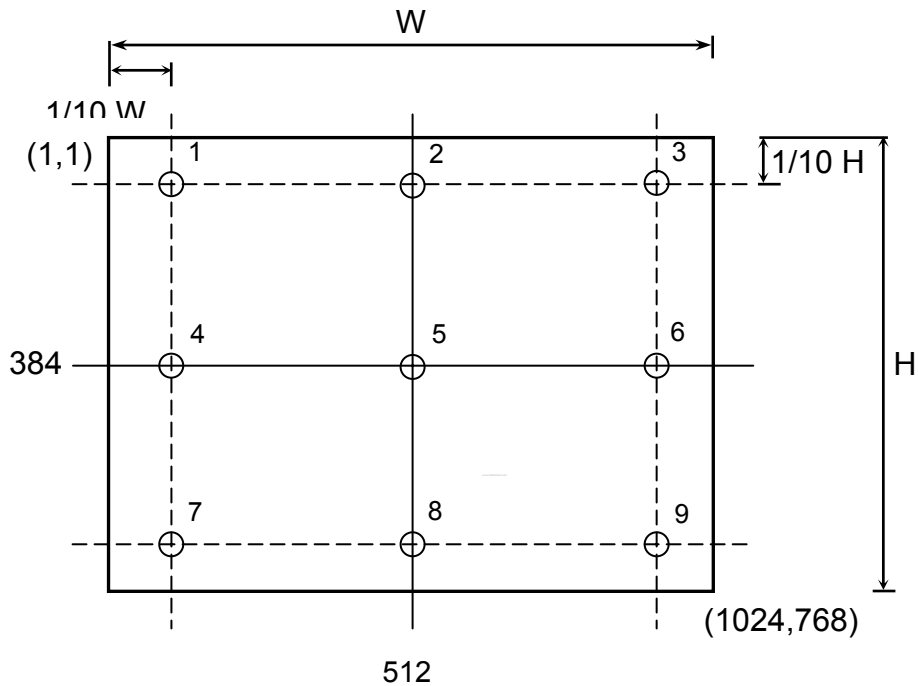
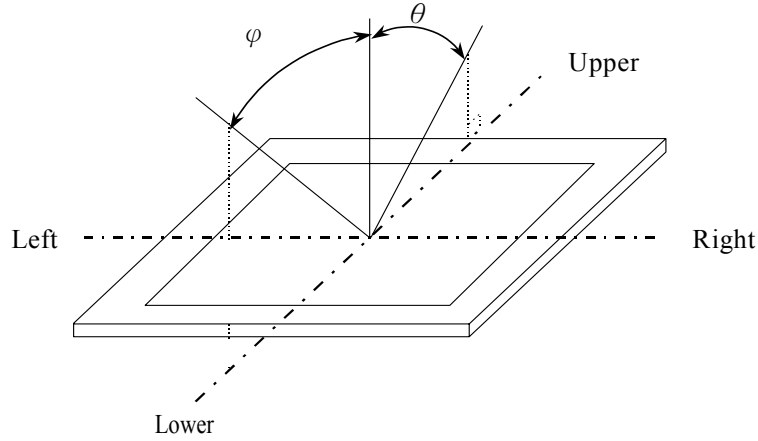

Figure 1. Measurement

Title : CLAA150XP07FQ Technical Specification

*3) Definition of Viewing Angle(θ, ϕ)



*4) Definition of Response Time

Change the module frame to Black/white pattern and use Westar TDR-100 to measure tr and tf under 25°C room temperature.

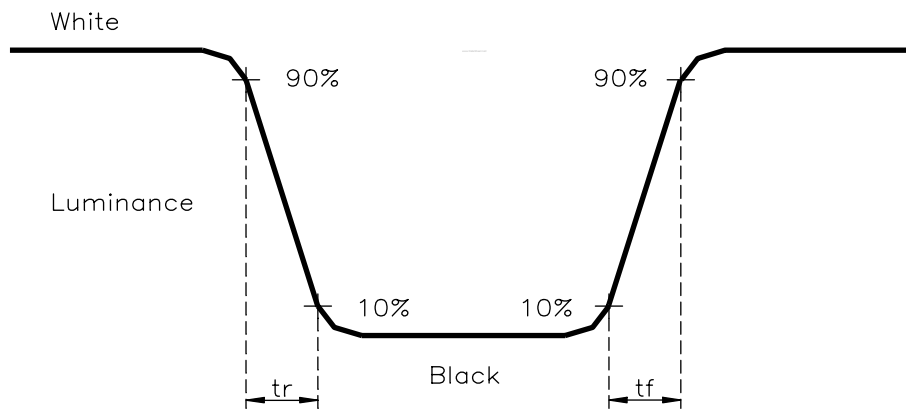

Title : CLAA150XP07FQ Technical Specification

*5) Definition of image sticking

Continuously display the test pattern showing in the below figure for (4hrs) at 25°C, then switch to gray pattern (the 120nd gray level pattern).

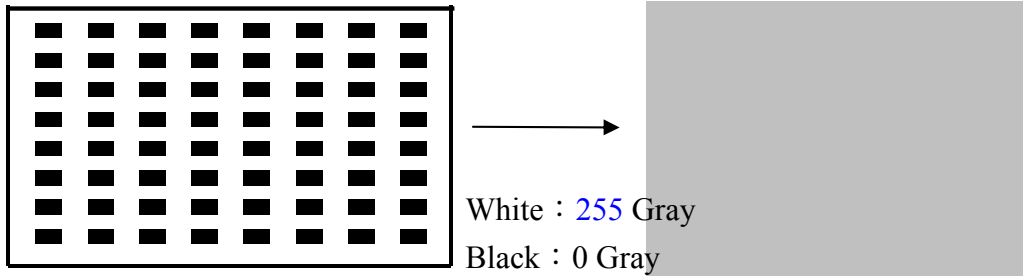

Judgment standard		
Rank	Statement	Judgment
Rank 0	No image sticking.	OK
Rank 1	Image doesn't disappear in 3 seconds.	OK
Rank 2	Image doesn't disappear in 3 seconds, but it looks like Mura Rank 2 as standard sample.	OK
Rank 3	Image doesn't disappear in 3 seconds, and it still looks serious 5 minutes later.	NG

*6) Cross talk Modulation Ratio:

$$CMR = \text{MAX} ((| (LB1-LA)/LA |) \times 100\%, (| (LB2-LA)/LA |) \times 100\%)$$

LA : Pattern A (Half-Tone pattern) measurement point luninance

LB1 、 LB2 : Pattern B1 、 B2 measurement point luninance

Title : CLAA150XP07FQ Technical Specification

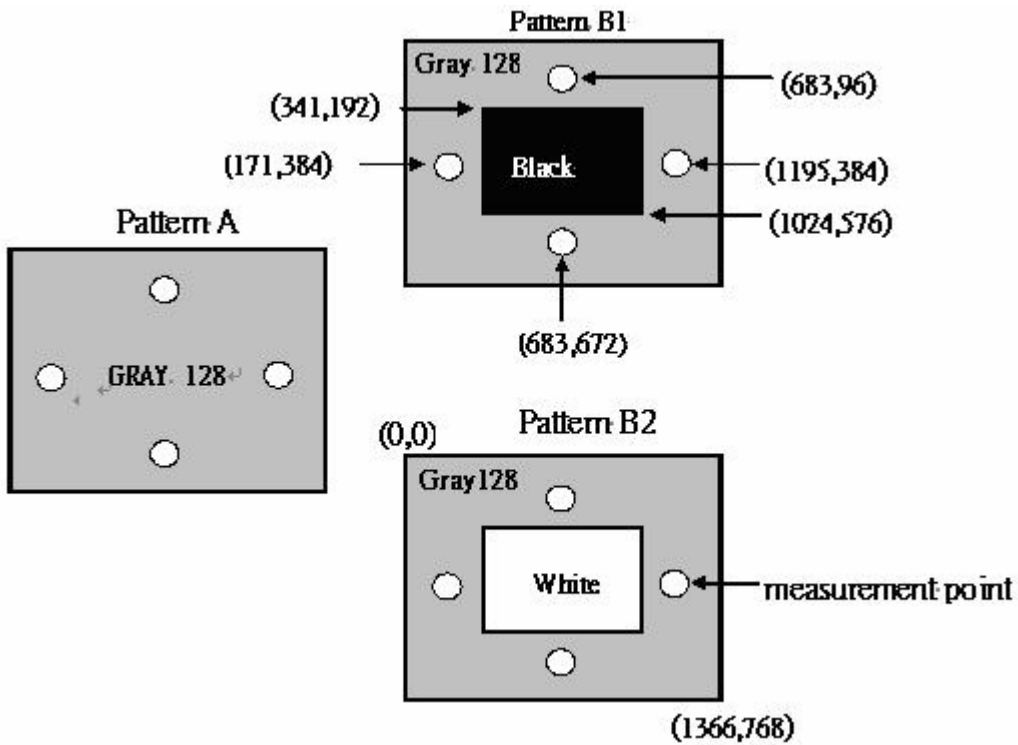

*7) Defination Gamma(VESA)

Based on Customer Sample, take the average value as a standard center value and the variation range of Gamma value caused by loop voltage error should be between +/- 0.2. the bellow figure shows how to obtain the gamma curve and γ (from gray level: 0、16、32----224、240、255).

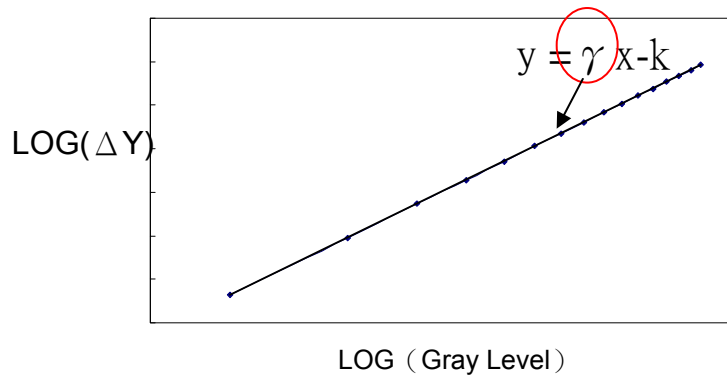

Title : CLAA150XP07FQ Technical Specification

9. RELIABILITY TEST CONDITIONS

(1) Temperature 、 Pressure and Humidity

TEST ITEMS	CONDITIONS
High Temperature High Humidity Operation	50°C ; 90%RH; 240hrs (No condensation)
High Temperature High Humidity Storage	60°C ; 90%RH; 48hrs (No condensation)
Temperature & Pressure Operation	(0°C ; 260hpa; 24hrs)
Temperature & Pressure Storage	(-30°C ; 260hpa; 24hrs)
High Temperature Operation	50°C ; 240hrs
High Temperature Storage	60°C ; 240hrs
Low Temperature Operation	0°C ; 240hrs
Low Temperature Storage	-20°C ; 240hrs
Thermal Shock	Between -20°C (1hr) ~ 60°C (1hr); 100 Cycles

(2) Shock & Vibration

ITEMS	CONDITIONS
Shock (Non-Operation)	Shock level: 1470 m/s ² (150 G) Waveform: half sinusoidal wave, 2 ms Number of shocks: one shock input in each direction of three mutually perpendicular axes for a total of six shock inputs
Vibration (Non-Operation)	Vibration level: 10.78 m/s ² (1.1 G) Waveform: sinusoidal wave Frequency range: 5 to 500 Hz Frequency sweep rate: 0.5 octave/min Duration: one sweep from 5 to 500Hz in each of three mutually perpendicular axis(each x, y, z axis: 1 hour, total 3 hours)

(3) ESD testing

Test Item	Test statements
Connector	200 pF, 0 Ω, ±250 V By using contact-mode to discharge each pin one time (every 1sec) and then check the module frame.
Module	1. Test statements: 150 pF, 330 Ω, ±15kV Under non-operation testing conditions, by using air-mode to discharge each test point 25 times (discharge time space:1s) continuously and then check the module frame. 2. Test statements: 150pF, 330Ω, ±2KV Under operation testing conditions, by using contact mode to discharge the front bezel and using air mode to discharge the

Title : CLAA150XP07FQ Technical Specification

	points of panel.
--	------------------

(4) Judgment standard

The judgment of the above test should be made as follow:

Pass: Normal display image with no obvious non-uniformity and no line defect.

Partial transformation of the module parts should be ignored.

Fail: No display image, obvious non-uniformity, or line defects.

Title : CLAA150XP07FQ Technical Specification

10. HANDLING PRECAUTIONS FOR TFT-LCD MODULE

Please pay attention to the followings in handling- TFT-LCD products.

10.1 ASSEMBLY PRECAUTION

- (1) Please use the mounting hole on the module side in installing and do not beading or wrenching LCD in assembling. And please do not drop, bend or twist LCD module in handling.
- (2) Please design display housing in accordance with the following guidelines.
 - Housing case must be destined carefully so as not to put stresses on LCD all sides and not to wrench module. The stresses may cause non-uniformity even if there is no non-uniformity statically.
 - Keep sufficient clearance between LCD module back surface and housing when the LCD module is mounted. Approximately 1.0 mm of the clearance in the design is recommended taking into account the tolerance of LCD module thickness and mounting structure height on the housing.
 - When some parts, such as, FPC cable and ferrite plate, are installed underneath the LCD module, still sufficient clearance is required, such as 0.5mm. This clearance is, especially, to be reconsidered when the additional parts are implemented for EMI countermeasure.
 - Design the inverter location and connector position carefully so as not to give stress to lamp cable, or not to interface the LCD module by the lamp cable.
 - Keep sufficient clearance between LCD module and the others parts, such as inverter and speaker so as not to interface the LCD module. Approximately 1.0mm of the clearance in the design is recommended.
- (3) Please do not push or scratch LCD panel surface with any-thing hard. And do not soil LCD panel surface by touching with bare hands. (Polarizer film, surface of LCD panel is easy to be flawed.)
- (4) Please do not press any parts on the rear side such as source TCP, gate TCP, control circuit board and FPCs during handling LCD module. If pressing rear part is unavoidable, handle the LCD module with care not to damage them.
- (5) Please wipe out LCD panel surface with absorbent cotton or soft clothe in case of it being soiled.
- (6) Please wipe out drops of adhesives like saliva and water on LCD panel surface immediately. They might damage to cause panel surface variation and color change.
- (7) Please do not take a LCD module to pieces and reconstruct it. Resolving and reconstructing modules may cause them not to work well.
- (8) Please do not touch metal frames with bare hands and soiled gloves. A color change of the metal frames can happen during a long preservation of soiled LCD modules.

Title : CLAA150XP07FQ Technical Specification

- (9) Please pay attention to handling lead wire of backlight so that it is not tugged in connecting with inverter.

10.2 OPERATING PRECAUTIONS

- (1) Please be sure to turn off the power supply before connecting and disconnecting signal input cable.
- (2) Please do not change variable resistance settings in LCD module. They are adjusted to the most suitable value. If they are changed, it might happen LCD does not satisfy the characteristics specification.
- (3) Please consider that LCD backlight takes longer time to become stable of radiation characteristics in low temperature than in room temperature.
- (4) A condensation might happen on the surface and inside of LCD module in case of sudden change of ambient temperature.
- (5) Please pay attention to displaying the same pattern for very long time. Image might stick on LCD. If then, time going on can make LCD work well.
- (6) Please obey the same caution descriptions as ones that need to pay attention to ordinary electronic parts.

10.3 PRECAUTIONS WITH ELECTROSTATICS

- (1) This LCD module use CMOS-IC on circuit board and TFT-LCD panel, and so it is easy to be affected by electrostatics. Please be careful with electrostatics by the way of your body connecting to the ground and so on.
- (2) Please remove protection film very slowly on the surface of LCD module to prevent from electrostatics occurrence.

10.4 STORAGE PRECAUTIONS

- (1) When you store LCDs for a long time, it is recommended to keep the temperature between 0°C ~40°C without the exposure of sunlight and to keep the humidity less than 90%RH.
- (2) Please do not leave the LCDs in the environment of high humidity and high temperature such as 60°C 90%RH.
- (3) Please do not leave the LCDs in the environment of low temperature; below -20°C.

10.5 SAFETY PRECAUTIONS

- (1) When you waste LCDs, it is recommended to crush damaged or unnecessary LCDs into pieces and wash them off with solvents such as acetone and ethanol, which should later be burned.

Title : CLAA150XP07FQ Technical Specification

- (2) If any liquid leaks out of a damaged-glass cell and comes in contact with the hands, wash off throughly with soap and water.

10.6 OTHERS

- (1) A strong incident light into LCD panel might cause display characteristics' changing inferior because of polarizer film, color filter, and other materials becoming inferior. Please do not expose LCD module direct sunlight Land strong UV rays.
- (2) Please pay attention to a panel side of LCD module not to contact with other materials in preserving it alone.
- (3) For the packaging box, please pay attention to the followings:
- Packaging box and inner case for LCD are designed to protect the LCDs from the damage or scratching during transportation. Please do not open except picking LCDs up from the box.
 - Please do not pile them up more than 3 boxes. (They are not designed so.) And please do not turn over.
 - Please handle packaging box with care not to give them sudden shock and vibrations. And also please do not throw them up.
 - Packing box and inner case for LCDs are made of cardboard. So please pay attention not to get them wet. (Such like keeping them in high humidity or wet place can occur getting them wet.)

Title : CLAA150XP07FQ Technical Specification

11. PACKING FORM

- Package quantity in one carton: 10 pieces.
- Carton size:485(L)×365(W)×365(H) (unit : mm)
- For domestic transportation only.

Title : CLAA150XP07FQ Technical Specification

12. SAFETY

We will try our best comply the directive 2002/95/EC of the European, and that we will do our possible not to use or use exceeding the limits of banned substances. We also comply with product-related environmental laws and regulations in manufacturing process and do our best to achieve global environmental protection standards.