



# Chunghwa Picture Tubes, Ltd.

## Technical Specification

To

Date : 2004.11.22

**TFT LCD**

**CLAA154WA 01Y**

ACCEPTED BY :

APPROVED BY	CHECKED BY	PREPARED BY
		TFT-LCD Plant Product Planning Management General Division

Prepared by : TFT-LCD Product Planning Management General Division

**CHUNGHWA PICTURE TUBES, LTD.**

1127 Hopin Rd., Padeh, Taoyuan, Taiwan 334, R.O.C.  
TEL: +886-3-3675151 FAX: +886-3-377-3001

Doc.No:	CLAA154WA01Y-STUDIO-Ver1-20041122	Issue Date:	2004/11/22
---------	-----------------------------------	-------------	------------

T- 3650002- 000- A NEW

## 1. OVERVIEW

**CLAA154WA01Y**(with LVDS interface) is 15.4" color TFT-LCD (Thin Film Transistor Liquid Crystal Display) module composed of LCD panel , driver ICs , control circuit , and backlight.

By applying 6 bits digital data, 1280×800, 262K color images are displayed on the 15.0" diagonal screen. Input power voltage is single 3.3V for LCD driving.

Inverter for backlight is not included in this module. General specifications are summarized in the following table:

ITEM	SPECIFICATION
Display Area(mm)	331.2(H) x 207.0(V) (15.4-inch diagonal)
Number of Pixels	1280 x 3(H) x 800(V)
Pixel Pitch(mm)	0.25875(H) x 0.25875(V)
Color Pixel Arrangement	RGB vertical stripe
Display Mode	normally white TN
Number of Colors	262144 colors
Optimum Viewing Angle	6 o'clock
Brightness(cd/m <sup>2</sup> )	200(cd/m <sup>2</sup> (center);185(cd/m <sup>2</sup> (5 point) ,lamp current 6mA(typ)
Power consumption(W)	6.8
Module Size(mm)	344.0(W) x 222.0(H) x 6.0(D)(typ)
Module Weight(g)	600(typ)
Backlight Unit	CCFL , 1 tube
Surface Treatment	Anti-Glare(Haze value: 12%) ; Hardness: 3H

[Note] :

The LCD Products listed on this document are not suitable for use of aerospace equipment, submarine cables, nuclear reactor control system and life support systems. If customers intend to use these LCD products for above application or not listed in "Standard" as follows , please contact our sales people in advance.

Standard: Computer, Office equipment, Communication equipment, Test and Measurement equipment , Machine tool , Industrial robot , Audio and Visual equipment , Other consumer products.

## 2. ABSOLUTE MAXIMUM RATINGS

ITEM	SYMBOL	MIN.	MAX.	UNIT
Power Supply Voltage for LCD	VCC	0	4.0	V
LVDS input Voltage	VIN	-0.3	3.6	V
Static Electricity *1)	VESDt	-250	250	V
	VESDc	-15	15	KV
ICC Rush Current *2)	I <sub>RUSH</sub>		4.5	A
Operation Temperature *3)	Top	0	50	
Storage Temperature *3)	Tstg	-20	60	
Starting Lamp Voltage	V <sub>SL</sub>	-	2000	V

[Note] : \*1) Test Condition: IEC 1000-4-2 ,

VESDt : Contact discharge to input connector

VESDc : Contact discharge to module

\*2) 50 μ sec , If Vcc rise time increase then I<sub>RUSH</sub> decrease.

\*3) Humidity 85% RH. without condensation.

### 3. ELECTRICAL CHARACTERISTICS

(1) TFT-LCD

Ta = 25°C

ITEM	SYMBOL	MIN	TYP	MAX	UNIT	Remark
Power Supply Voltage for LCD	VCC	3.0	3.3	3.6	V	
Power Supply Current for LCD	ICC	-	650	1000	mA	
ICC Rush Current	I <sub>RUSH</sub>			4.5	A	
Logic input Voltage	Input Voltage	VIN	0	-	VCC	V
	Common Mode Voltage	VCM	1.125	1.25	1.375	V
	Differential Input Voltage	VID	250	350	450	mV
	Threshold Voltage(High)	VTH	-	-	100	mV
Threshold Voltage(Low)	VTL	-100	-	-	mV	
Tolerance of VID	VID	-	-	35	mV	
Tolerance of VCM	VCM	-	-	35	mV	

[Note 1]

VCC=3.3V

● VCC turn on conditions :

- |              |       |        |    |
|--------------|-------|--------|----|
| t1           | 10ms  | 1 sec  | t5 |
| 0.01 ms < t2 | 50 ms | 300 ms | t6 |
| 0.01 ms < t3 | 50 ms | 300 ms | t7 |
| 0.01 ms < t4 | 10 ms |        |    |

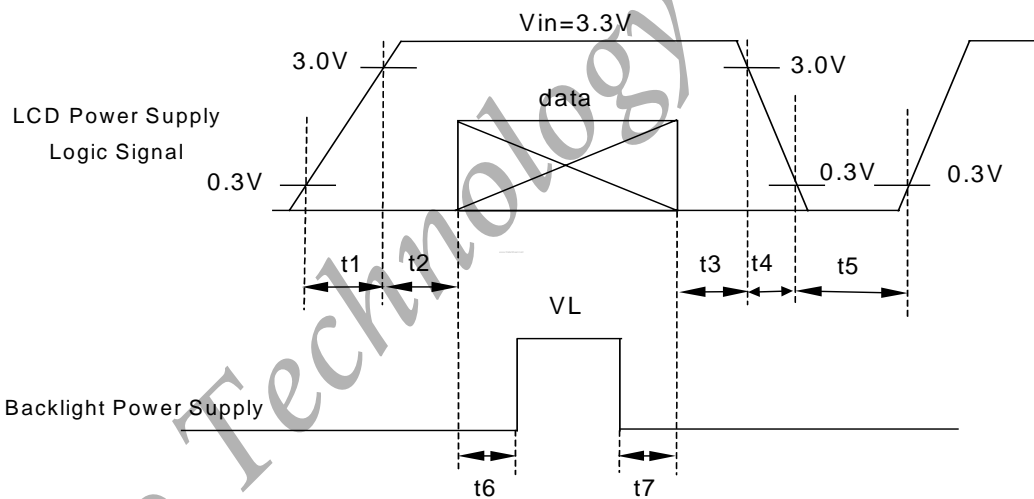

Data: RGB DATA, DCLK, HD, VD, DENA

● VCC dip conditions :

- 1) When 2.7V VCC<3.0V, td 10 ms
- 2) When VCC<2.7V, it works abnormal that must reset power.  
VCC dip conditions should follow VCC turn on conditions.

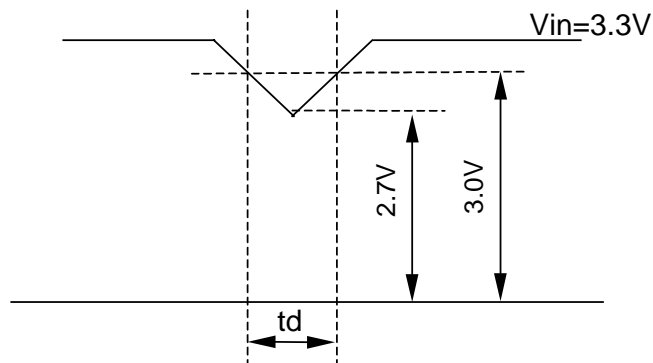

[Note 2]

- Typical value is measured when displaying horizontal gray scale line pattern  
64 gray level  
800 line mode  
VCC = +3.3V

[Note 3]

- LVDS Signal definition :

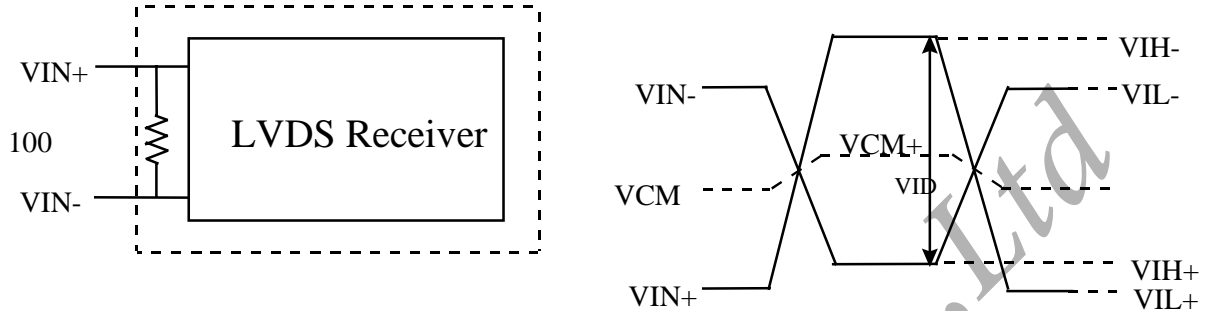

$$VID = VIN_+ - VIN_-$$

$$VCM = |VCM_+ - VCM_-|$$

$$VID_+ = |VIH_+ - VIH_-|$$

$$VID_- = |VIL_+ - VIL_-|$$

$$VCM = (VIN_+ + VIN_-) / 2$$

$$VCM_+ = (VIH_+ + VIH_-) / 2$$

$$VCM_- = (VIL_+ + VIL_-) / 2$$

VIN<sub>+</sub> = Positive differential DATA & CLK Input

VIN<sub>-</sub> = Negative differential DATA & CLK Input

(2) Backlight system

Ta = 25°C

ITEM	SYMBOL	MIN	TYP	MAX	UNIT
Lamp Voltage	VL	-	680	800	V
Lamp Current *1)	IL	3.0	6.0	6.5	mA
Inverter Frequency	FI	40	50	60	KHz
Lamp life time *2)	Life L	10000	-	-	hr
Starting Lamp Voltage	Ta = 25	-	-	1350	V
	Tb = 0	-	-	1755	

[Note 1]

\*1) Lamp Current measurement method ( The current meter is inserted in cold line)

Standard inverter : IM 4201 , typical luminance = 185 cd/m<sup>2</sup> (5 point).

\*2) The time that module luminance reduced to 50% of initial value .

Base on Vs = (1350) V , Ta = 25°C , IL=6.0 mA continuous.

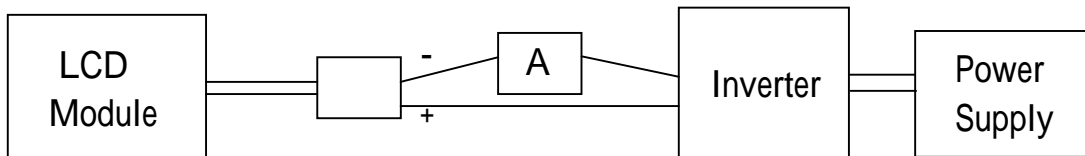

The lamp shall be stably lighted. Slide up method shall be used for input voltage application. The voltage is applied voltage to both ends of the lamp as the established starting voltage.

**[Note 2]**

Lamp frequency of inverter may produce interference with horizontal synchronous frequency, and this may cause horizontal beat on the display. Therefore, please adjust lamp frequency, and keep inverter as far from module as possible or use electronic shielding between inverter and module to avoid the interference.

The degrees of unbalance: less than 10%  
 The ratio of wave height: less than  $2 \pm 10\%$

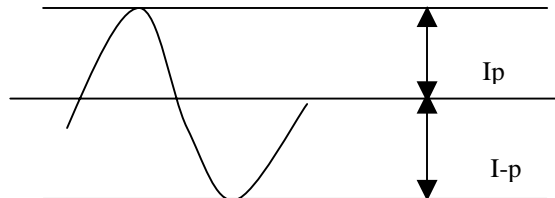

The degrees of unbalance =  $\frac{|I_p - I_p|}{I_{rms}} * 100(\%)$

The ratio of wave height =  $I_p$  (or  $I_p$ ) /  $I_{rms}$

$I_p$ : lamp current high side peak,  $I_p$ : lamp current low side peak

**[Note 3]**

Definition of the lamp life time

Luminance: L under 50% of specification

Starting Lamp Voltage:  $V_S < 1350V$ ,  $T_a = 25$

$V_S < 1755V$ ,  $T_b = 0$

## 4. INTERFACE CONNECTION

### (1) CN1 ( INTERFACE SIGNAL )

\* Connector type : FI-XB30SL-HF10 (JAE made)

pin	Symbol	Function
1	VSS	Ground
2	VCC	+3.3V
3	VCC	+3.3V
4	V_EDID	DDC 3.3V Power
5	NC	VCOM test provided , but customer-end unused (open)
6	CLK_EDID	DDC Clock
7	DATA_EDID	DDC Data
8	R0M	minus signal of channel 0(LVDS)
9	R0P	plus signal of channel 0(LVDS)
10	Ground	Ground
11	R1M	minus signal of channel 1(LVDS)
12	R1P	plus signal of channel 1(LVDS)
13	Ground	Ground
14	R2M	minus signal of channel 2(LVDS)
15	R2P	plus signal of channel 2(LVDS)
16	Ground	Ground
17	RCLKM	minus signal of clock channel (LVDS)
18	RCLKP	plus signal of clock channel (LVDS)
19	Ground	Ground
20	NC	No connect
21	NC	No connect
22	NC	No connect
23	NC	No connect
24	NC	No connect
25	NC	No connect
26	NC	No connect
27	NC	No connect
28	NC	No connect
29	NC	No connect
30	NC	No connect

(Note) DDC: Display Data Requirements

(Note)Reference Page 8、9、10、11 Data Mapping

### (2) CN2 ( BACK LIGHT )

- Backlight-side connector : BHSR-02VS-1(JST made)
- Inverter-side connector : SM02B-BHSS-1(JST made)

Pin No.	Symbol	Function
1	CTH	VBLH (High voltage)
2	CTL	VBLL (Low voltage)

[Note] VBLH-VBLL = VL

### 5. Input Signal Timing

(1) LVDS (Rx) Input Signal Timing Chart

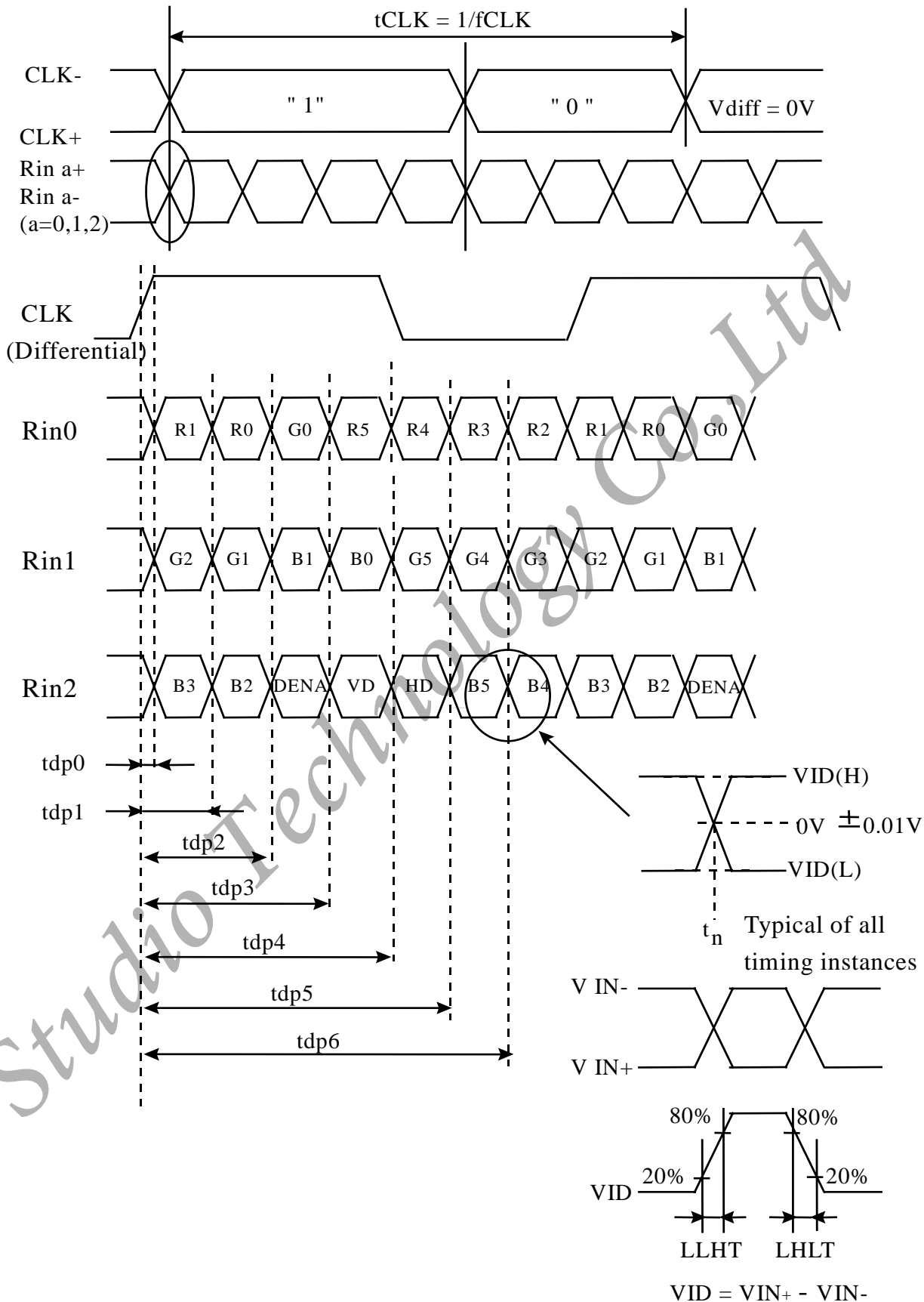

(2) LCD (Tx) Input Signal Timing Chart : ( Rx output)

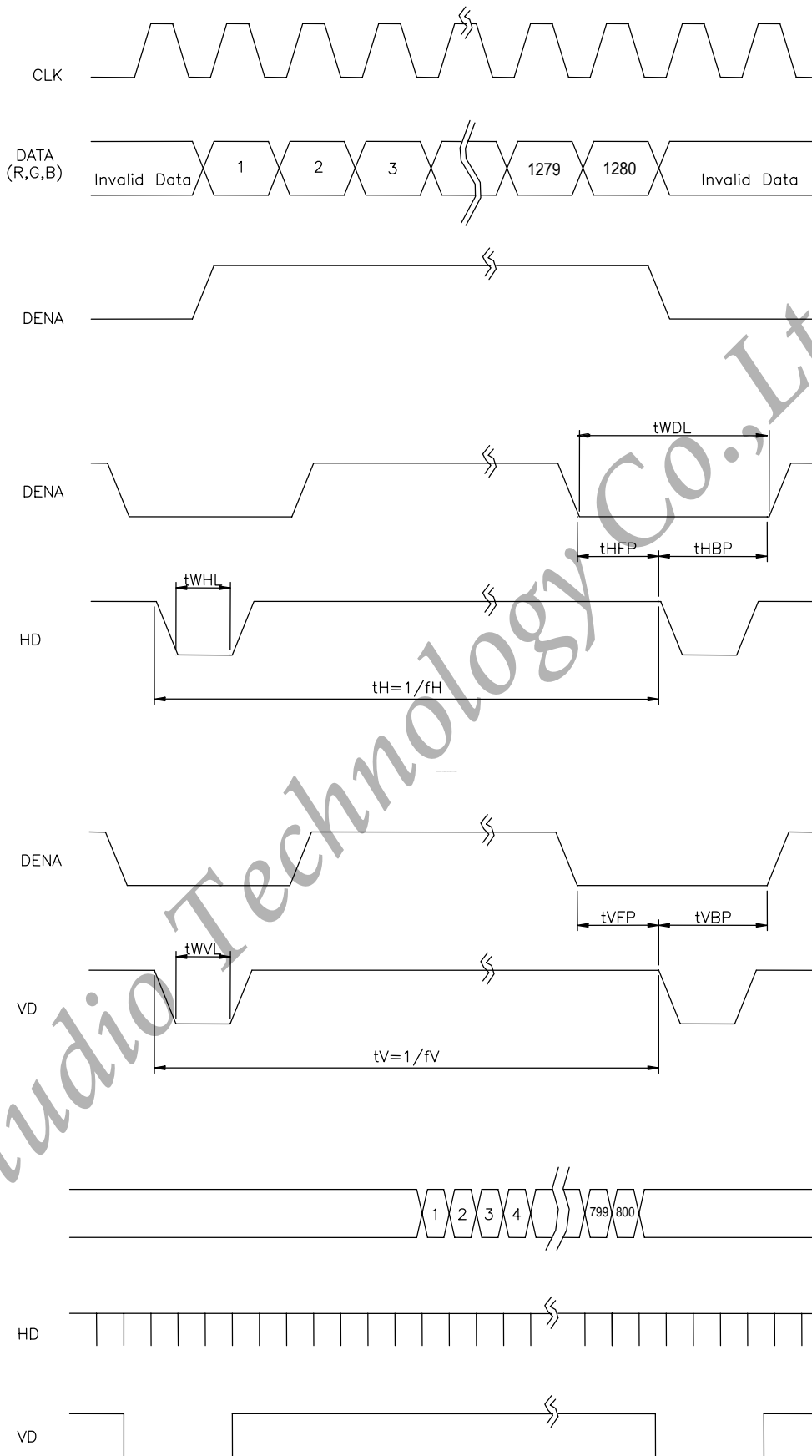



## (3)Timing Specifications

ITEM		SYMBOL	MIN	TYP	MAX	UNIT	
LVDS Input Timing	CLK frequency	fCLKin	-	68.9	-	MHz	
	CLK period	tCLKin	-	14.5	-	ns	
	LVDS High to Low transition time	LLHT	-	0.75	1.5	ns	
	LVDS Low to High transition time	LHLT	-	0.75	1.5	ns	
	Strobe position of Bit 0	f = 68.9MHz	Rspos0	0.7	1.1	1.4	ns
	Strobe position of Bit 1		Rspos1	2.9	3.3	3.6	ns
	Strobe position of Bit 2		Rspos2	5.1	5.5	5.8	ns
	Strobe position of Bit 3		Rspos3	7.3	7.7	8.0	ns
	Strobe position of Bit 4		Rspos4	9.5	9.9	10.2	ns
	Strobe position of Bit 5		Rspos5	11.7	12.1	12.4	ns
Strobe position of Bit 6	Rspos6		13.9	14.3	14.6	ns	
LCD input signal  ( LVDS Tx Input , Rx output )	DENA	Low width	tWDL	64	128	220	tCLK
		Horizontal Front Porch	tHFP	24	54	84	tCLK
		Horizontal Back Porch	tHBP	40	74	136	tCLK
		Vertical Front Porch	tVFP	0	3	6	tH
		Vertical Back Porch	tVBP	10	13	24	tH
	HD	Frequency	fH	45.9	48.96	51.3	kHz
		Period	tH	1344	1408	1500	tCLK
		Low width	tWHL	12	24	36	tCLK
	VD	Frequency	fV	55	60	63	Hz
		Period	tV	810	816	830	tH
Low width		tWVL	1	3	7	tH	

**[Note]**

- 1) Polarities of HD and VD are negative in this specification.
- 2) DENA (Data Enable) should always be positive polarity as shown in the timing specification.
- 3) CLKIN should appear during all invalid period, and HD should appear during invalid period of frame cycle.
- 4) Data is latched at fall edge of DCLK in this specification.

(4) Color data definition

COLOR	INPUT DATA	R DATA						G DATA						B DATA									
		R5	R4	R3	R2	R1	R0	G5	G4	G3	G2	G1	G0	B5	B4	B3	B2	B1	B0				
		MSB						LSB						MSB						LSB			
Basic Color	BLACK	0	0	0	0	0	0	0	0	0	0	0	0	0	0	0	0	0	0				
	RED(63)	1	1	1	1	1	1	0	0	0	0	0	0	0	0	0	0	0	0				
	GREEN(63)	0	0	0	0	0	0	1	1	1	1	1	1	0	0	0	0	0	0				
	BLUE(63)	0	0	0	0	0	0	0	0	0	0	0	0	1	1	1	1	1	1				
	CYAN	0	0	0	0	0	0	1	1	1	1	1	1	1	1	1	1	1	1				
	MAGENTA	1	1	1	1	1	1	0	0	0	0	0	0	1	1	1	1	1	1				
	YELLOW	1	1	1	1	1	1	1	1	1	1	1	1	0	0	0	0	0	0				
	WHITE	1	1	1	1	1	1	1	1	1	1	1	1	1	1	1	1	1	1				
RED	RED(0)	0	0	0	0	0	0	0	0	0	0	0	0	0	0	0	0	0	0				
	RED(1)	0	0	0	0	0	1	0	0	0	0	0	0	0	0	0	0	0	0				
	RED(2)	0	0	0	0	1	0	0	0	0	0	0	0	0	0	0	0	0	0				
	/	/	/	/	/	/	/	/	/	/	/	/	/	/	/	/	/	/	/				
	/	/	/	/	/	/	/	/	/	/	/	/	/	/	/	/	/	/	/				
	RED(62)	1	1	1	1	1	0	0	0	0	0	0	0	0	0	0	0	0	0				
	RED(63)	1	1	1	1	1	1	0	0	0	0	0	0	0	0	0	0	0	0				
GREEN	GREEN(0)	0	0	0	0	0	0	0	0	0	0	0	0	0	0	0	0	0	0				
	GREEN(1)	0	0	0	0	0	0	0	0	0	0	0	1	0	0	0	0	0	0				
	GREEN(2)	0	0	0	0	0	0	0	0	0	0	1	0	0	0	0	0	0	0				
	/	/	/	/	/	/	/	/	/	/	/	/	/	/	/	/	/	/	/				
	/	/	/	/	/	/	/	/	/	/	/	/	/	/	/	/	/	/	/				
	GREEN(62)	0	0	0	0	0	0	1	1	1	1	1	0	0	0	0	0	0	0				
	GREEN(63)	0	0	0	0	0	0	1	1	1	1	1	1	0	0	0	0	0	0				
BLUE	BLUE(0)	0	0	0	0	0	0	0	0	0	0	0	0	0	0	0	0	0	0				
	BLUE(1)	0	0	0	0	0	0	0	0	0	0	0	0	0	0	0	0	0	1				
	BLUE(2)	0	0	0	0	0	0	0	0	0	0	0	0	0	0	0	0	1	0				
	/	/	/	/	/	/	/	/	/	/	/	/	/	/	/	/	/	/	/				
	/	/	/	/	/	/	/	/	/	/	/	/	/	/	/	/	/	/	/				
	BLUE(62)	0	0	0	0	0	0	0	0	0	0	0	0	1	1	1	1	1	0				
	BLUE(63)	0	0	0	0	0	0	0	0	0	0	0	0	1	1	1	1	1	1				

[Note]

- (1) Definition of gray scale:  
 Color(n) : n means level of gray scale .  
 Bigger n means brighter level.
- (2)Data : 1= High , 0 = Low

(5)Color Data Assignment

D(1,1)	D(2,1)	--	D(X,1)	--	D(1279,1)	D(1280,1)
D(1,2)	D(2,2)	--	D(X,2)	--	D(1279,2)	D(1280,2)
		+	..	+		
D(1,Y)	D(2,Y)	--	D(X,Y)	--	D(1279,Y)	D(1280,Y)
		+	..	+		
D(1,799)	D(2, 799)	--	D(X, 799)	--	D(1279,799)	D(1280,799)
D(1,800)	D(2, 800)	--	D(X, 800)	--	D(1279,800)	D(1280,800)

6. BLOCK DIAGRAM

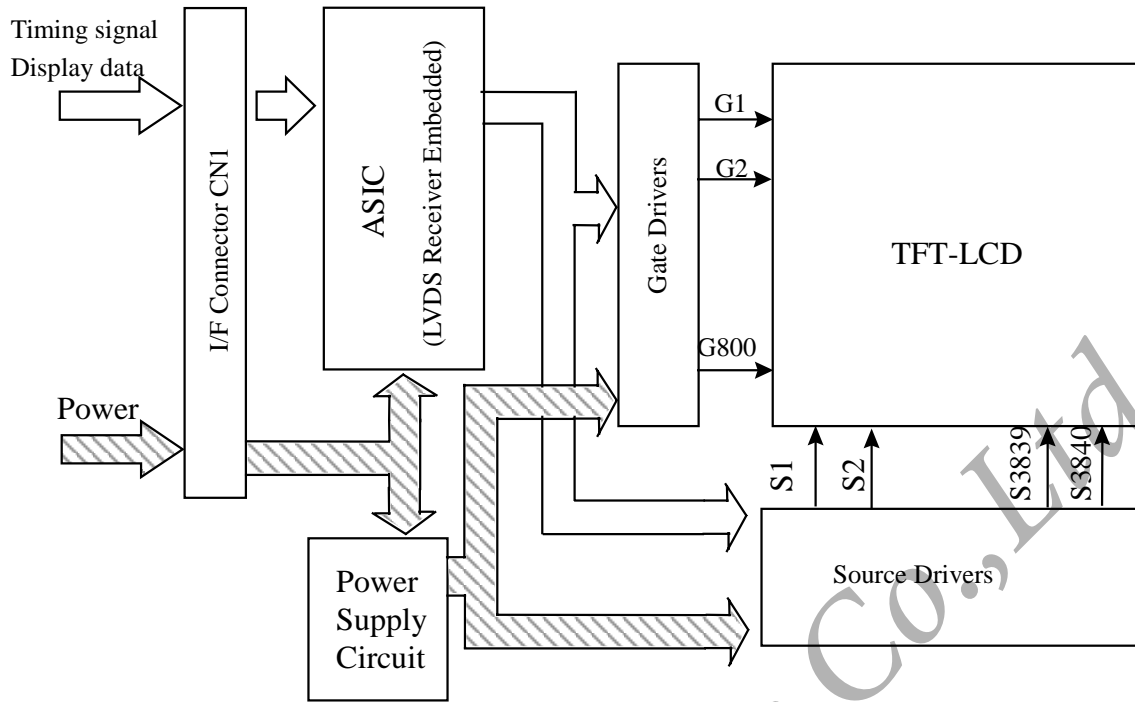

BACK LIGHT

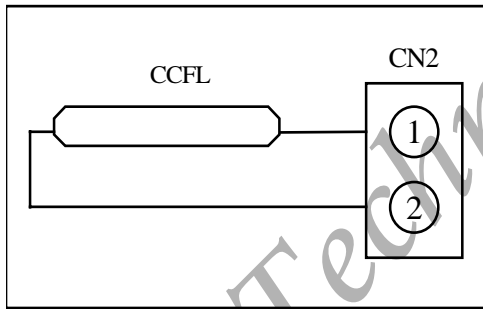

INVERTER CIRCUIT (OUT SIDE)

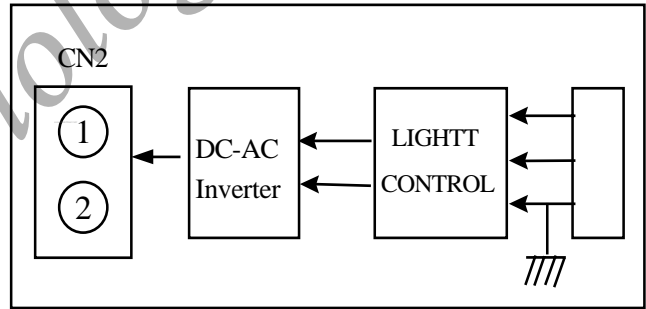

7. MECHANICAL DIMENSION

(1) Front side

Unit : mm

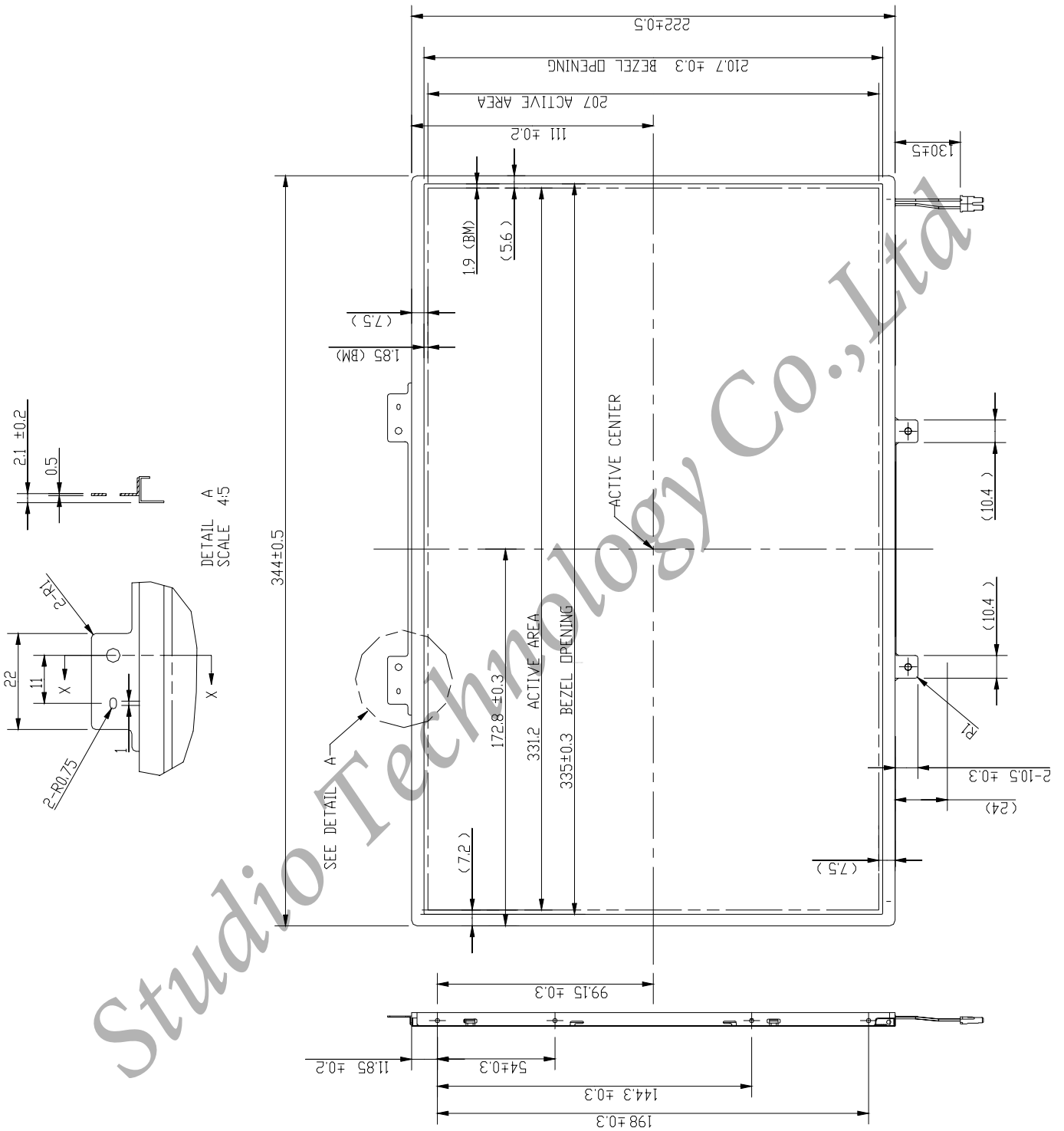

[Note] Undefined tolerances to be  $\pm 0.5$  mm

(2) Rear side

Unit : mm

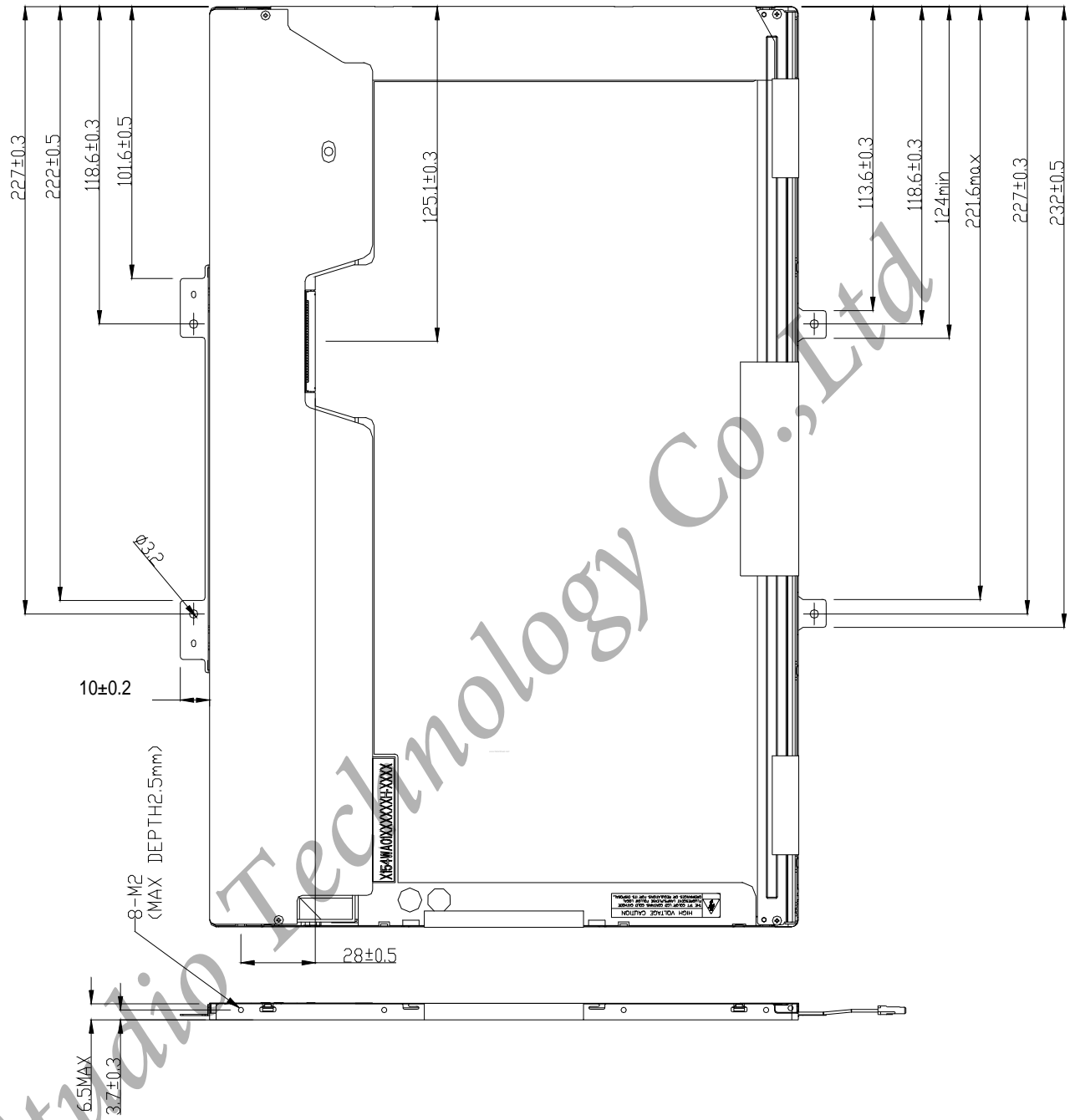

[Note] Undefined tolerances to be  $\pm 0.5$  mm

## 8. OPTICAL CHARACTERISTICS

Ta = 25°C

ITEM		SYMBOL	CONDITION	MIN.	TYP.	MAX.	UNIT	
Contrast Ratio		CR	$\theta = \phi = 0^\circ$	300	400	--	--	
Luminance	Center	L	$\theta = \phi = 0^\circ$	160	200	--	cd/m <sup>2</sup>	
	5 point	Normal	L	$\theta = \phi = 0^\circ$	150	185	--	cd/m <sup>2</sup>
		Uniformity	$\Delta L$	$\theta = \phi = 0^\circ$	--	30	40	%
Response Time		Tr	$\theta = \phi = 0^\circ$	--	8	30	ms	
		Tf	$\theta = \phi = 0^\circ$	--	20	50	ms	
Image Sticking		Tis	2hour	--	--	2	sec	
Crosstalk		CMR	$\theta = \phi = 0^{*3}$	--	-	1	%	
Viewing Angle	Horizontal		CR 10	--	-65~65	--	°	
	Vertical	$\theta$		--	-55~45	--	°	
Color Coordinates	White	Wx	$\theta = \phi = 0^\circ$	0.283	0.313	0.343	--	
		Wy		0.299	0.329	0.359		
	Red	Rx		0.582	0.612	0.642		
		Ry		0.315	0.345	0.375		
	Green	Gx		0.281	0.311	0.341		
		Gy		0.536	0.566	0.596		
	Blue	Bx		0.124	0.154	0.184		
		By		0.106	0.136	0.166		

**[Note]**

These items are measured using BM-5A(TOPCON) under the dark room condition( no ambient light) after more than 30 minutes from turning on the lamp unless noted.

Condition: IL=6.0 mA, Inverter Frequency=50kHz.

Definition of these measurement items as follows:

(1)Definition of Contrast Ratio :  $CR = \text{ON(White)Luminance} / \text{OFF(Black)Luminance}$

(2)Definition of Luminance and Luminance uniformity :

Measure White Luminance on the below 5 center and take the average value.

Uniformity :  $\Delta L = [(L_{MAX} - L_{MIN}) / L_{MIN}] \times 100\%$

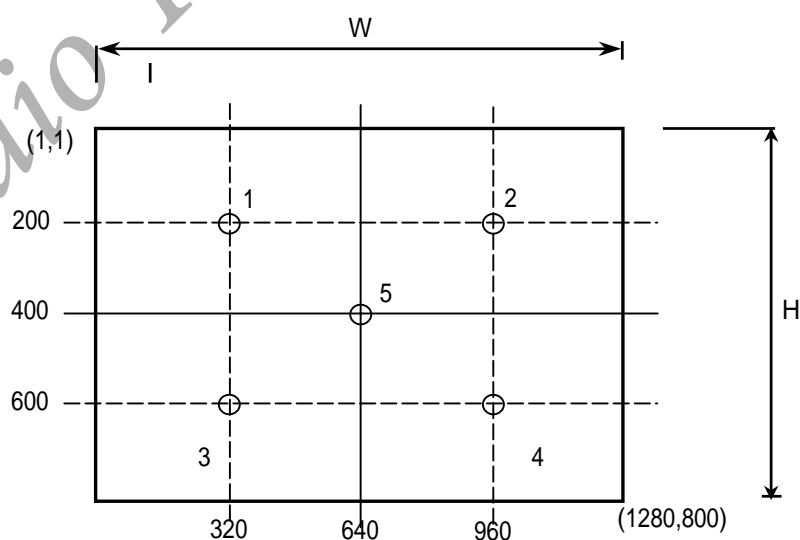

(3) Definition of Viewing Angle( , )

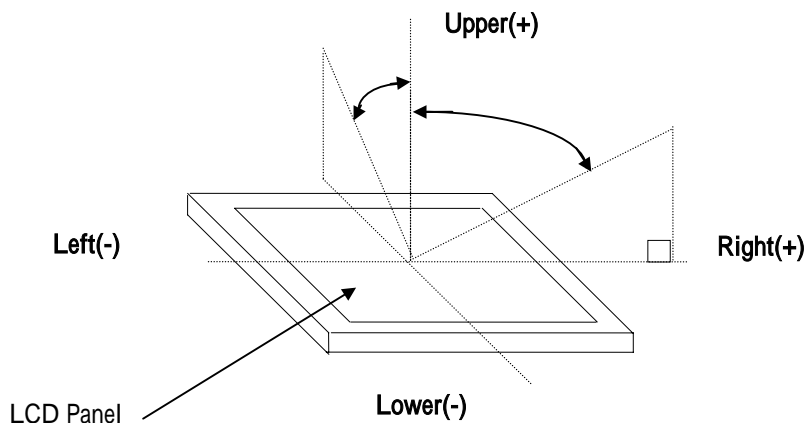

(4) Definition of Response Time

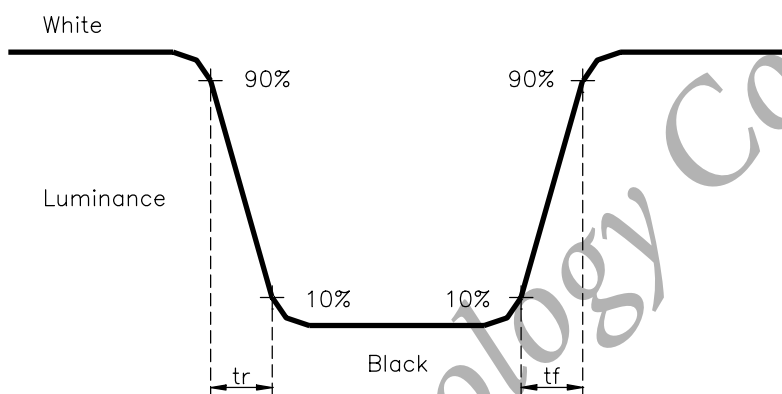

(5) Definition of Contrast Ratio Uniformity

$$CR = [CR(MAX) / CR(MIN) - 1] \times 100$$

(6) Definition of Luminance Uniformity

$$L = [L(MAX) / L(MIN) - 1] \times 100$$

(7) Definition of Image Sticking

From Continuous display pattern (white “R” with blue background) 2hours change to 128 gray level pattern .The previous image shall not persist more then 2 second at 25 C.

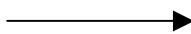
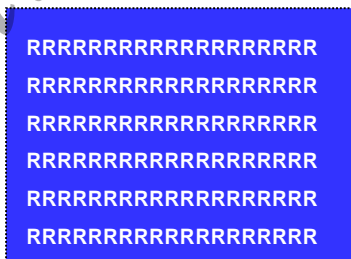

## (8) Definition of Cross talk Modulation Ratio

$$CMR = \text{MAX} \left( \left( \frac{LB1-LA}{LC} \right) \times 100, \left( \frac{LB2-LA}{LC} \right) \times 100 \right)$$

LA : Pattern A(Half-Tone pattern) Measure point Luminance

LB1, LB2 : Pattern B1、 Pattern B2 Measure point Luminance

LC : Pattern C(white pattern) Measure point Luminance

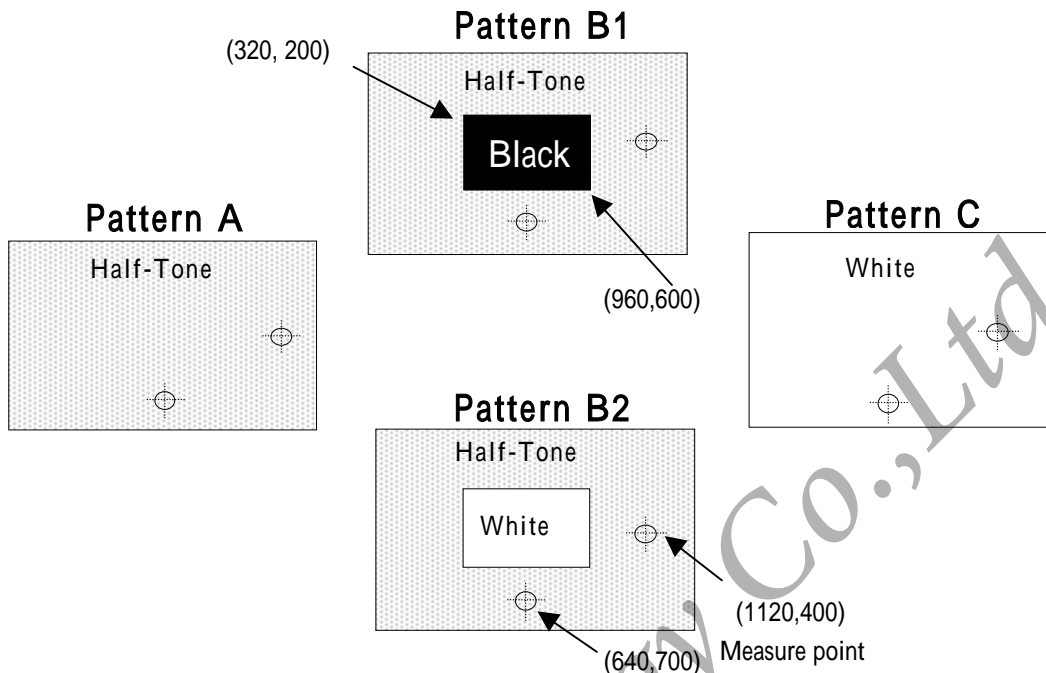

## 9. RELIABILITY TEST CONDITIONS

### (1) Temperature and Humidity

TEST ITEMS	CONDITIONS
HIGH TEMPERATURE OPERATION	50 ,240h
HIGH TEMPERATURE STORAGE	60 ,240h
LOW TEMPERATURE OPERATION	0 ,240h
LOW TEMPERATURE STORAGE	-20 ,240h
HIGH TEMPERATURE HIGH HUMIDITY OPERATION	40 ,90%RH,240h(No condensat ion)
HIGH TEMPERATURE HIGH HUMIDITY STORAGE	60 ,90%RH(Max),48h(No condensat ion)
THERMAL SHOCK(No operation)	BETWEEN -20 (1h)AND 60 (1h),100 CYCLES

### (2) Shock & Vibration

ITEMS	CONDITIONS
SHOCK (NON-OPERATION)	<ul style="list-style-type: none"> <li>● Shock level: 1764 m/s<sup>2</sup> (180G)</li> <li>● Waveform: half sinusoidal wave, 2ms</li> <li>● Number of shocks: one shock input in each direction of three mutually perpendicular axes for a total of six shock inputs.</li> </ul>
VIBRATION (NON-OPERATION)	<ul style="list-style-type: none"> <li>● Vibration level: 9.8 m/s<sup>2</sup> (1.0G) , sinusoidal wave, perpendicular axis(each x,y,z axis: 1hr , total 3 hrs)</li> <li>● Frequency range: 5 to 500 Hz</li> <li>● Sweep speed : 0.5 octave / min</li> </ul>

### (3) Judgment standard

The judgment of the above test should be made as follow:

Pass: Normal display image with no obvious non-uniformity and no line defect.

Partial transformation of the module parts should be ignored.

Fail: No display image, obvious non-uniformity, or line defects.



## 10. HANDLING PRECAUTIONS FOR TFT-LCD MODULE

Please pay attention to the followings in handling- TFT-LCD products;

### (A) ASSEMBLY PRECAUTION

- (1) Please use the mounting hole on the module side in installing and do not beading or wrenching LCD in assembling. And please do not drop, bend or twist LCD module in handling.
- (2) Please design display housing in accordance with the following guide lines.
  - (2.1) Housing case must be destined carefully so as not to put stresses on LCD all sides and not to wrench module. The stresses may cause non-uniformity even if there is no non-uniformity statically.
  - (2.2) Keep sufficient clearance between LCD module back surface and housing when the LCD module is mounted. Approximately 1.0 mm of the clearance in the design is recommended taking into account the tolerance of LCD module thickness and mounting structure height on the housing.
  - (2.3) When some parts, such as, FPC cable and ferrite plate, are installed underneath the LCD module, still sufficient clearance is required, such as 0.5mm. This clearance is, especially, to be reconsidered when the additional parts are implemented for EMI countermeasure.
  - (2.4) Design the inverter location and connector position carefully so as not to give stress to lamp cable, or not to interface the LCD module by the lamp cable.
  - (2.5) Keep sufficient clearance between LCD module and the others parts, such as inverter and speaker so as not to interface the LCD module. Approximately 1.0mm of the clearance in the design is recommended.
- (3) Please do not push or scratch LCD panel surface with any-thing hard. And do not soil LCD panel surface by touching with bare hands. ( Polarizer film, surface of LCD panel is easy to be flawed.)
- (4) Please do not press any parts on the rear side such as source TCP, gate TCP, control circuit board and FPCs during handling LCD module. If pressing rear part is unavoidable, handle the LCD module with care not to damage them.
- (5) Please wipe out LCD panel surface with absorbent cotton or soft cloth in case of it being soiled.
- (6) Please wipe out drops of adhesives like saliva and water on LCD panel surface immediately. They might damage to cause panel surface variation and color change.
- (7) Please do not take a LCD module to pieces and reconstruct it. Resolving and reconstructing modules may cause them not to work well.
- (8) Please do not touch metal frames with bare hands and soiled gloves. A color change of the metal frames can happen during a long preservation of soiled LCD modules.
- (9) Please pay attention to handling lead wire of backlight so that it is not tugged in connecting wit inverter.

### (B) OPERATING PRECAUTIONS

- (1) Please be sure to turn off the power supply before connecting and disconnecting signal input cable.
- (2) Please do not change variable resistance settings in LCD module. They are adjusted to the most suitable value. If they are changed, it might happen LCD does not satisfy the characteristics specification.
- (3) Please consider that LCD backlight takes longer time to become stable of radiation characteristics in low temperature than in room temperature.
- (4) A condensation might happen on the surface and inside of LCD module in case of sudden change of ambient temperature.
- (5) Please pay attention to displaying the same pattern for very long time. Image might stick on LCD. If then, time going on can make LCD work well.

- (6) Please obey the same caution descriptions as ones that need to pay attention to ordinary electronic parts.

**(C) PRECAUTIONS WITH ELECTROSTATICS**

- (1) This LCD module use CMOS-IC on circuit board and TFT-LCD panel, and so it is easy to be affected by electrostatics. Please be careful with electrostatics by the way of your body connecting to the ground and so on.
- (2) Please remove protection film very slowly on the surface of LCD module to prevent from electrostatics occurrence.

**(D) STORAGE PRECAUTIONS**

- (1) When you store LCDs for a long time, it is recommended to keep the temperature between 0°C-40°C without the exposure of sunlight and to keep the humidity less than 90%RH.
- (2) Please do not leave the LCDs in the environment of high humidity and high temperature such as 60°C 90%RH.
- (3) Please do not leave the LCDs in the environment of low temperature; below -20°C.

**(E) SAFETY PRECAUTIONS**

- (1) When you waste LCDs, it is recommended to crush damaged or unnecessary LCDs into pieces and wash them off with solvents such as acetone and ethanol, which should later be burned.
- (2) If any liquid leaks out of a damaged-glass cell and comes in contact with the hands, wash off thoroughly with soap and water.

**(F) OTHERS**

- (1) A strong incident light into LCD panel might cause display characteristics' changing inferior because of polarizer film, color filter, and other materials becoming inferior. Please do not expose LCD module direct sunlight and strong UV rays.
- (2) Please pay attention to a panel side of LCD module not to contact with other materials in preserving it alone.
- (3) For the packaging box, please pay attention to the followings:
  - (3.1) Packaging box and inner case for LCD are designed to protect the LCDs from the damage or scratching during transportation. Please do not open except picking LCDs up from the box.
  - (3.2) Please do not pile them up more than 5 boxes. (They are not designed so.) And please do not turn over.
  - (3.3) Please handle packaging box with care not to give them sudden shock and vibrations. And also please do not throw them up.
  - (3.4) Packing box and inner case for LCDs are made of cardboard. So please pay attention not to get them wet. (Such like keeping them in high humidity or wet place can occur getting them wet.)