



Chunghwa Picture Tubes, Ltd.

Technical Specification

To :

Date : 2006/3/8

CPT TFT-LCD
CLAA154WA05

ACCEPTED BY :

APPROVED BY	CHECKED BY	PREPARED BY

Prepared by : TFT-LCD Product Planning Management Division

CHUNGHWA PICTUER TUBES, LTD.

1127 Hopin Rd., Padeh, Taoyuan, Taiwan 334, R.O.C.
TEL: +886-3-3675151 FAX: +886-3-377-3001

Doc.No:	CLAA154WA05-V1-2006/3/8	Issue Date:	2006/3/8
---------	-------------------------	-------------	----------

T- 3650002- 000- A
NEW

1. OVERVIEW

CLAA154WA05 is 15.4" color TFT-LCD (Thin Film Transistor Liquid Crystal Display) module composed of LCD panel, LVDS driver ICs, control circuit and backlight. By applying 6 bit digital data, 1280x800, 262K-color images are displayed on the 15.4" diagonal screen. Interface of data and control signals is Typ. 68.9 MHz digital. Inverter for backlight is not included in this module. General specification are summarized in the following table:

ITEM	SPECIFICATION
Display Area(mm)	331.2(H) x 207.0(V) (15.4-inch diagonal)
Number of Pixels	1280x 3(H) x 800(V)
Pixel Pitch(mm)	0.25875(H) x 0.25875(V)
Color Pixel Arrangement	RGB vertical stripe
Display Mode	normally white TN
Number of Colors	262,144 colors
Optimum Viewing Angle	6 o'clock
Brightness(cd/m ²)	190cd/m ² (center),170 cd/m ² (5 point) @6mA(Typ.)
View angle	-40°~ 40° / -40°~20°
Power consumption(W)	6.5W(typ), 7.0W(max)
Module Size(mm)	344.5(W)×222.5(H)×6.2(D)(max.)
Module Weight(g)	585(Max.)
Backlight Unit	1 tube ,Edge light (Bottom)

The LCD Products listed on this document are not suitable for use of aerospace equipment, submarine cables, and nuclear reactor control system and life support systems. If customers intend to use these LCD products for above application or not listed in "Standard" as follows, please contact our sales people in advance.

Standard: Computer, Office equipment, Communication equipment, Test and Measurement equipment, Machine tool, Industrial robot, Audio and Visual equipment, Other consumer products.

2. ABSOLUTE MAXIMUM RATINGS

ITEM	SYMBOL	MIN.	MAX.	UNIT	Remark
Power Supply Voltage for LCD	VCC	0	4.0	V	
Lamp voltage	VL	710	960	V _{rms}	
Lamp current	IL	3	6.5	mA _{rms}	*1)*2)
Lamp frequency	FL	50	80	kHz	
Operation Temperature	Top	0	50	°C	*3)*4)*5)*6)
Storage Temperature	Tstg	-20	60	°C	*3)*4)*5)
Delayed Discharge Time	TD	--	1	sec	*7)

The following are maximum values which, if exceeded, may cause faulty operation or damage to the unit.

[Note]

- *1) Product life-time related to lamp current, pls operate the production follow statement at page 8
- *2) When lamp current over the definition of absolute maximum, product life-time will decay rapidly or operate unusual.
- *3) The relative temperature and humidity range are as below sketch, 90%RHMax. ($T_a \leq 40^\circ\text{C}$)
- *4) The maximum wet bulb temperature $\leq 39^\circ\text{C}$ ($T_a > 40^\circ\text{C}$) and without dewing
- *5). If you use the product in a environment which over the definition of temperature and humidity too long to effect the result of eye-atching.
- *6) If you operate the product in normal temperature range, the center surface of panel should be under 60°C .
 Humidity :
 Humidity $\leq 85\%RH$ without condensation.
 Relative Humidity $\leq 90\%$ ($T_a \leq 40^\circ\text{C}$)
 Wet Bulb Temperature $\leq 39^\circ\text{C}$ ($T_a \geq 40^\circ\text{C}$)
- *7) Delayed discharge time test condition:
 starting lamp voltage = $1650V_{rms}$
 Before test TD, lamp should operate at least 1min. , and lamp current should follow typical lamp current specification. To place panel at room temp. ($25 \pm 2^\circ\text{C}$) below for 24hr, and then to measue TD with the same starting lamp voltage in dark room.

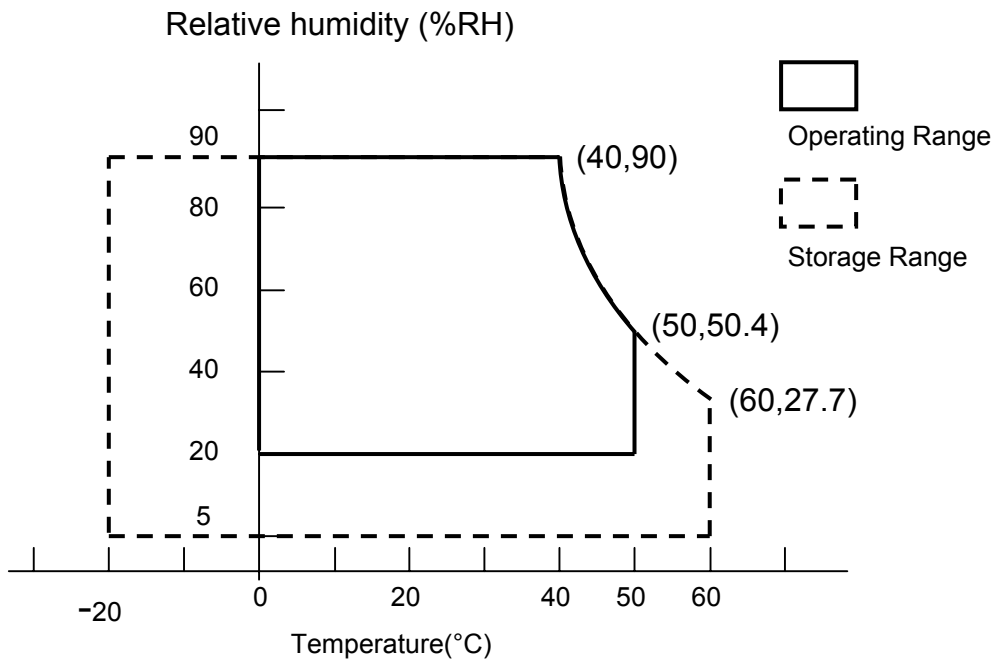

3. ELECTRICAL CHARACTERISTICS

3.1 TFT-LCD

Ta=25°C

ITEM	SYMBOL	MIN	TYP	MAX	UNIT	Remark	
Power Supply Voltage for LCD	VCC	3.0	3.3	3.6	V	*1)	
Power Supply Current for LCD	ICC	-	440	550	mA	*2)	
Rush Current	Irush	-	-	2.0	A	*3)	
Logic input Voltage *4)	Input Voltage	VIN	0	-	VCC	V	
	Common Mode Voltage	VCM	1.125	1.25	1.375	V	
	Differential Input Voltage	VID	250	350	450	mV	
	Threshold Voltage(High)	VTH	-	-	100	mV	When VCM=+1.2V
	Threshold Voltage(Low)	VTL	-100	-	-	mV	
Tolerance of VID	ΔVID	-	-	35	mV		
Tolerance of VCM	ΔVCM	-	-	35	mV		

[Note]

*1)

- Power sequence(VCC turn on conditions) :

$$\begin{aligned}
 t1 &\leq 10 \text{ ms} & 1\text{sec} &\leq t5 \\
 0.01\text{ms} < t2 &\leq 50\text{ms} & 200\text{ms} &\leq t6 \\
 0.01\text{ms} < t3 &\leq 50\text{ms} & 200\text{ms} &\leq t7 \\
 0.01\text{ms} < t4 &\leq 10 \text{ ms} & &
 \end{aligned}$$

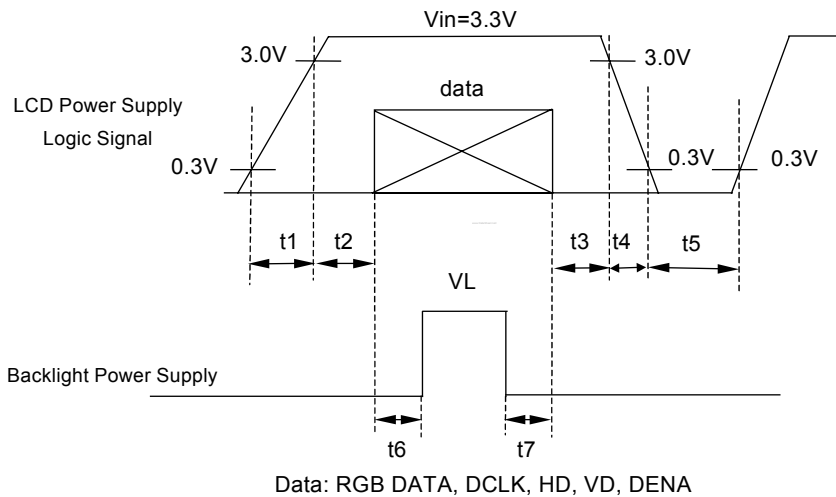

- VCC dip conditions:
 - 1) When $3.0 > VCC \geq 2.7V$, $t_d \leq 10 \text{ ms}$
 - 2) When $VCC < 2.7V$, it works abnormal that must reset power. VCC dip conditions should follow VCC turn on conditions.

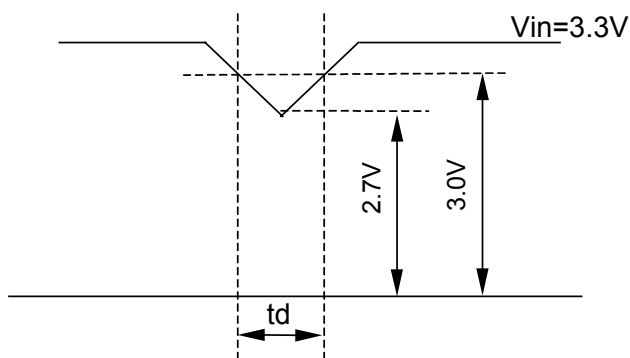

*2)

- Typical value is measured when displaying horizontal gray scale line pattern

$V_{CC}=3.3 V$, $f_v=60 Hz$, $f_i=48.9 kHz$, $f_{CLK}=68.9 MHz$

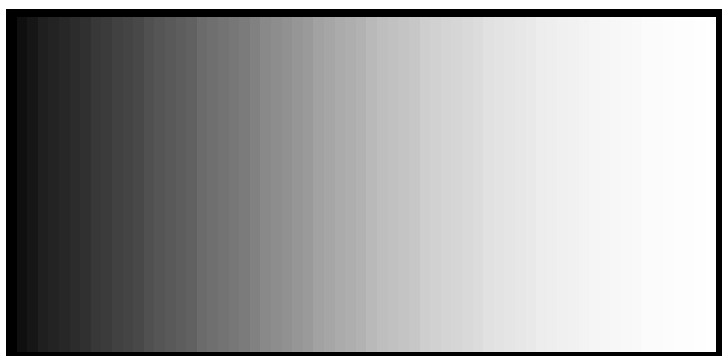

64-Gray :
0 ~ 63Gray

- Maximum value is measured when displaying horizontal gray scale line pattern

$V_{CC}=3.3 V$, $f_v=60 Hz$, $f_i=48.9 kHz$, $f_{CLK}=68.9 MHz$

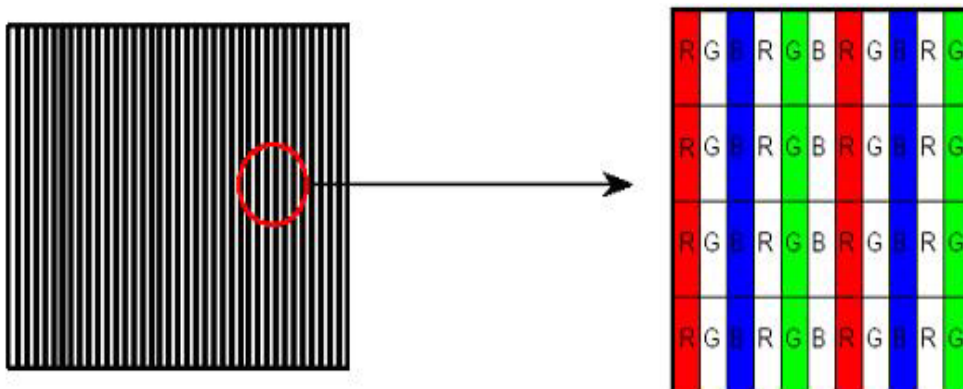

*3) Irush Measurement Condition

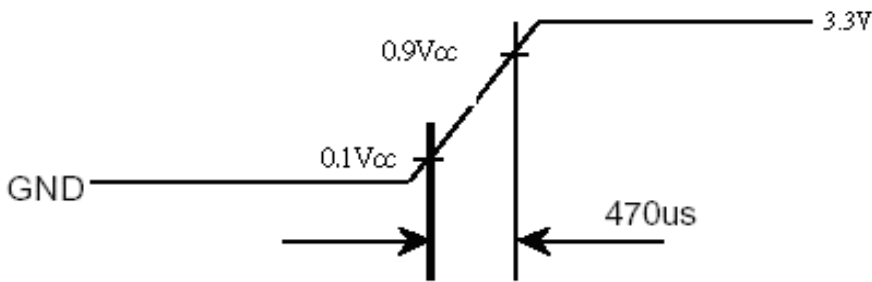
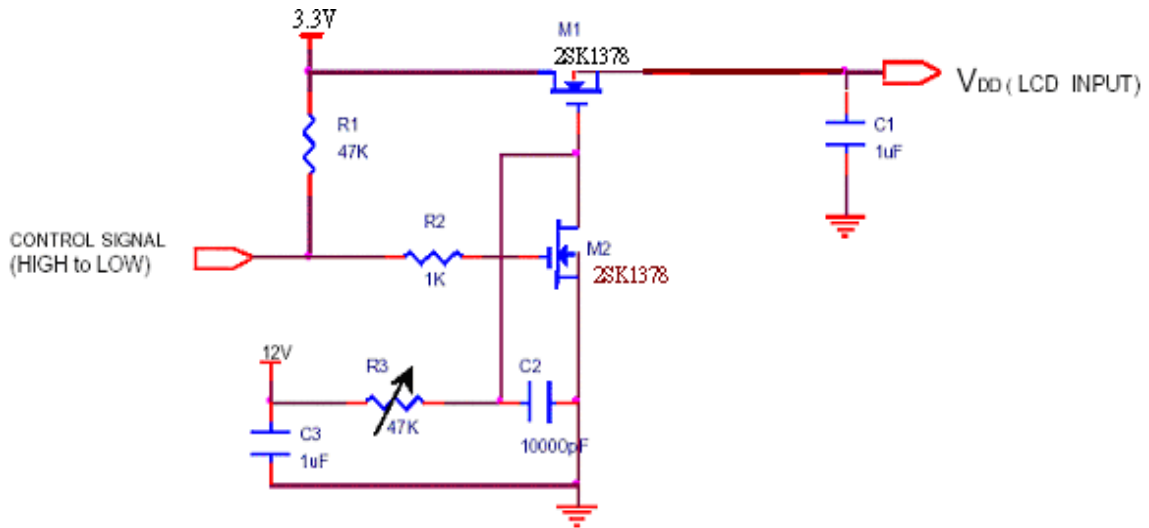

*4) LVDS Signal definition :

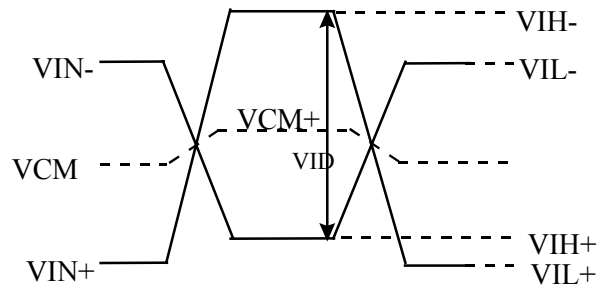
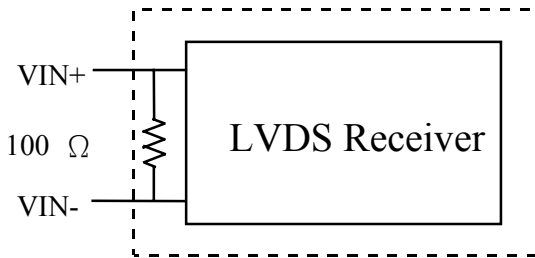

$$VID = VIN_+ - VIN_-$$

$$\Delta VCM = |VCM_+ - VCM_-|$$

$$\Delta VID = |VID_+ - VID_-|$$

$$VID_+ = |VIH_+ - VIH_-|$$

$$VID_- = |VIL_+ - VIL_-|$$

$$VCM = (VIN_+ - VIN_-) / 2$$

$$VCM_+ = (VIH_+ - VIH_-) / 2$$

$$VCM_- = (VIL_+ - VIL_-) / 2$$

VIN₊ = Positive differential DATA & CLK Input

VIN₋ = Negative differential DATA & CLK Input

3.2 Backlight *1)

(A) Electrical Characteristics

Ta=25°C

ITEM	SYMBOL	MIN	TYP	MAX	UNIT	REMARK
Lamp Voltage	VL	657	730	803	Vrms	IL=6.0mA
Lamp Current	IL	5.5	6.0	6.5	mArms	*2)
Inverter Frequency	FI	40	--	80	kHz	*3)
Starting Lamp Voltage	VS	1460	--	--	Vrms	Ta=25°C
		1650	--	--	Vrms	Ta=0°C

(B) Lamp Life Time

ITEM	IL at 3.0 mA	IL at 6.0 mA	IL at 6.5 mA	UNIT	REMARK
Lamp Life Time	--	Min. 10,000	--	hr	Continuous Operation*4)
Turn-on and Turn-off Operation	--	Min.100,000	--	time	Continuous Operation*5)

[Note]

*1) Inverter : SUMIDA , mode : IV11145T

If the waveform of light up-driving is asymmetric, the distribution of mercury inside the lamp tube will become unequal or will deplete the Ar gas in it. Then it may cause the abnormal phenomenon of lighting-up. Therefore, designers have to try their best to fulfill the conditions under the inverter designing-stage as below:

- The degrees of unbalance : < 10%
- The ratio of wave height : $< \sqrt{2} \pm 10\%$

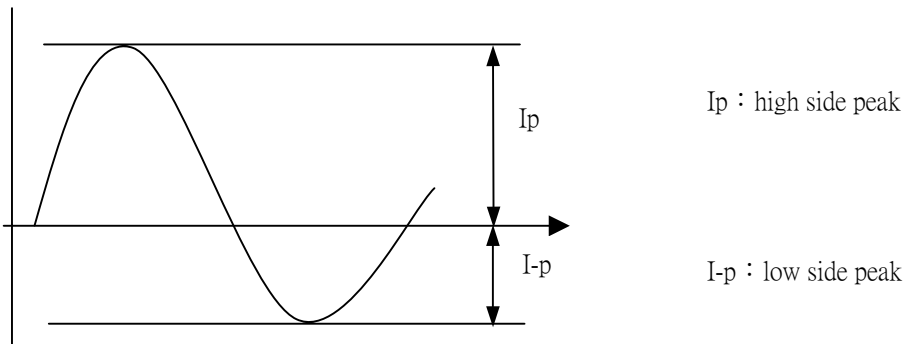

A : The degrees of unbalance = $| Ip - I-p | / Irms \times 100 (\%)$

B : The ratio of wave height = $Ip \text{ (or } I-p) / Irms$

*2) Lamp Current measurement method (The current meter is inserted in cold line)

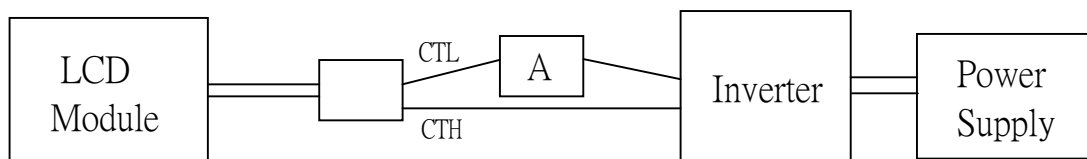

*3)

a. Frequency in this range can mala the characteristics of electric and optics maintain in +/- 10% except hue.

- b. Under optimum operate frequency range (50~60 kHz), have better electrical and optical characterics.
- c. Lamp frequency of inverter may produce interference with horizontal synchronous frequency, and this may cause horizontal beat on the display. Therefore, please adjust lamp frequency, and keep inverter as far from module as possible or use electronic shielding between inverter and module to avoid the interference.
- d. Under optimum operate frequency range (40~80 kHz), will not effect panel life-time and reliability .

*4) Definition of the lamp life time :

- a. Luminance (L) under 50% of specification starting lamp voltage
- b. Starting Lamp Voltage > 130 % * initial value (the room temperature)

*5)The condition of Turn-on and Turn-off operation is as below:

- a. Lamp current is 6.0mA
- b. Frequency is 10 sec.(on)/10 sec.(off)
- c. Repeat it for 100,000 times
- d. The lamp hue variation must smaller than 0.03
- e. It should not have motion fail when starting lamp voltage is lower than 130%of the initial value.
- f. the lamp luminance > initial value* 50%

4. INTERFACE PIN CONNECTION

4.1 CN1

Outlet connector: FI-XB30SL-HF10 (JAE)

Plug connector: FI-X30H (JAE)

Pin No.	REMARK	FUNCTION
1	Vss	Ground
2	Vin	+3.3V power supply
3	Vin	+3.3V power supply
4	V_EDID	DDC 3.3V Power
5	NC	VCOM test provided , but customer-end unused (open)
6	CLK_EDID	DDC Clock
7	DATA_EDID	DDC Data
8	ROM	minus signal of channel 0(LVDS)
9	R0P	plus signal of channel 0(LVDS)
10	Vss	Ground
11	R1M	minus signal of channel 1(LVDS)
12	R1P	plus signal of channel 1(LVDS)
13	Vss	Ground
14	R2M	minus signal of channel 2(LVDS)
15	R2P	plus signal of channel 2(LVDS)
16	Vss	Ground
17	RCLKM	minus signal of clock channel (LVDS)
18	RCLKP	plus signal of clock channel (LVDS)
19	Vss	Ground
20	NC	No connect
21	NC	No connect
22	NC	No connect
23	NC	No connect
24	NC	No connect
25	NC	No connect
26	NC	No connect
27	NC	No connect
28	NC	No connect
29	NC	No connect
30	NC	No connect

4.2 CN2 (BACKLIGHT)

Backlight-side connector: BHR-02VS-1 (JST)

Inverter-side connector: SM02B-BHSS-1-TB (JST)

PIN #	SYMBOL	FUNCTION
1	CTH	VBLH (High voltage)
2	CTL	VBLL (Low voltage)

[Note] : VBLH-VBLL=VL

5. INTERFACE TIMING

5.1 LVDS (Rx) Input Signal Timing Chart

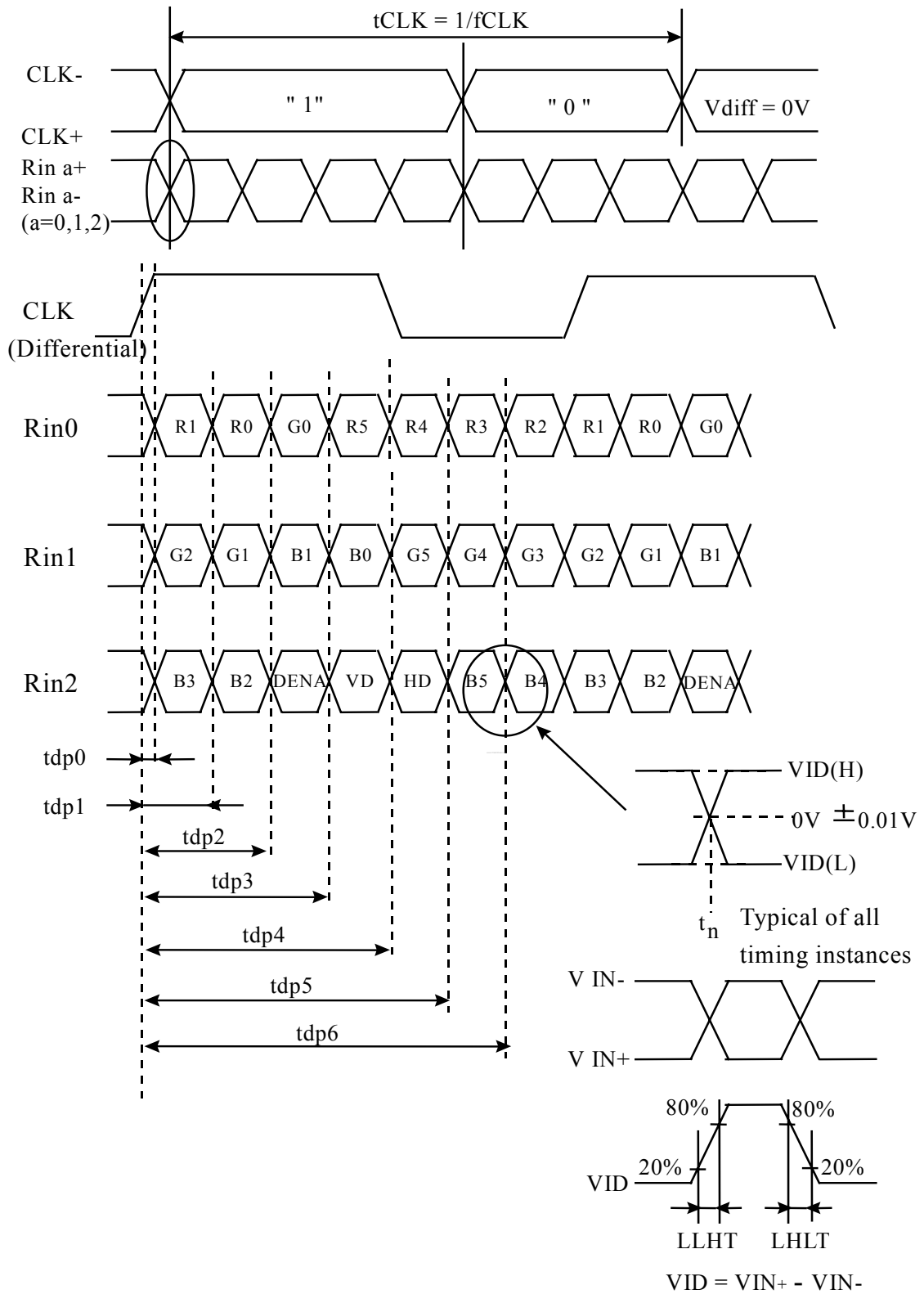

5.2 LCD (Tx) Input Signal Timing Chart : (Rx output)

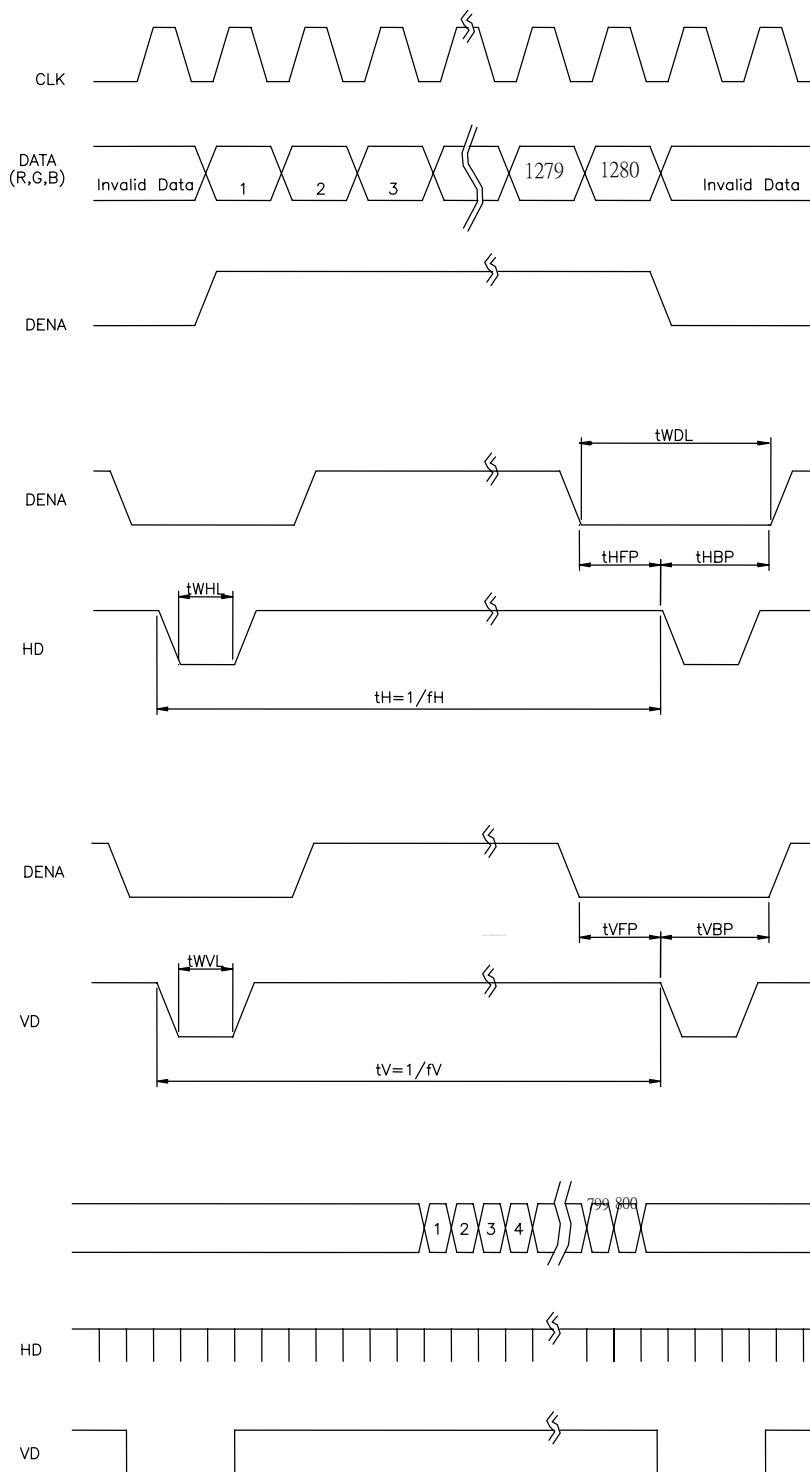

5.3 Timing Specifications

ITEM		SYMBOL	MIN	TYP	MAX	UNIT	
LVDS Input Timing *1),*4)	CLK frequency	fCLKin	-	68.9	-	MHz	
	CLK period	tCLKin	-	14.5	-	ns	
	LVDS High to Low transition time	LLHT	-	0.75	1.5	ns	
	LVDS Low to High transition time	LHLT	-	0.75	1.5	ns	
	Strobe position of Bit 0	f = 68.9MHz	Rspos0	0.7	1.1	1.4	ns
	Strobe position of Bit 1		Rspos1	2.9	3.3	3.6	ns
	Strobe position of Bit 2		Rspos2	5.1	5.5	5.8	ns
	Strobe position of Bit 3		Rspos3	7.3	7.7	8.0	ns
	Strobe position of Bit 4		Rspos4	9.5	9.9	10.2	ns
	Strobe position of Bit 5		Rspos5	11.7	12.1	12.4	ns
Strobe position of Bit 6	Rspos6		13.9	14.3	14.6	ns	
LCD input signal (LVDS Tx Input , Rx output)	DENA *3)	Low width	tWDL	64	128	220	tCLK
		Horizontal Front Porch	tHFP	24	54	84	tCLK
		Horizontal Back Porch	tHBP	40	74	136	tCLK
		Vertical Front Porch	tVFP	0	3	6	tH
		Vertical Back Porch	tVBP	10	13	24	tH
	HD *2)	Frequency	fH	45.9	48.96	51.3	kHz
		Period	tH	1344	1408	1500	tCLK
		Low width	tWHL	12	24	36	tCLK
	VD *2)	Frequency	fV	55	60	62	Hz
		Period	tV	810	816	830	tH
		Low width	tWVL	1	3	7	tH

[Note]

- *1)Data is latched at fall edge of DCLK in this specification.
- *2)Polarities of HD and VD are negative in this specification.
- *3)DENA (Data Enable) should always be positive polarity as shown in the timing specification.
- *4)DCLK should appear during all invalid period, and HD should appear during invalid period of frame cycle.

5.4 COLOR DATA ASSIGNMENT

Color	Input Data	R DATA						G DATA						B DATA					
		R5	R4	R3	R2	R1	R0	G5	G4	G3	G2	G1	G0	B5	B4	B3	B2	B1	B0
		MSB					LSB	MSB					LSB	MSB					LSB
Basic Color	Black	0	0	0	0	0	0	0	0	0	0	0	0	0	0	0	0	0	0
	Red(63)	1	1	1	1	1	1	0	0	0	0	0	0	0	0	0	0	0	0
	Green(63)	0	0	0	0	0	0	1	1	1	1	1	1	0	0	0	0	0	0
	Blue(63)	0	0	0	0	0	0	0	0	0	0	0	0	1	1	1	1	1	1
	Cyan	0	0	0	0	0	0	1	1	1	1	1	1	1	1	1	1	1	1
	Magenta	1	1	1	1	1	1	0	0	0	0	0	0	1	1	1	1	1	1
	Yellow	1	1	1	1	1	1	1	1	1	1	1	1	0	0	0	0	0	0
White	1	1	1	1	1	1	1	1	1	1	1	1	1	1	1	1	1	1	
RED	RED(0)	0	0	0	0	0	0	0	0	0	0	0	0	0	0	0	0	0	0
	RED(1)	0	0	0	0	0	1	0	0	0	0	0	0	0	0	0	0	0	0
	RED(2)	0	0	0	0	1	0	0	0	0	0	0	0	0	0	0	0	0	0
	RED(62)	1	1	1	1	1	0	0	0	0	0	0	0	0	0	0	0	0	0
RED(63)	1	1	1	1	1	1	0	0	0	0	0	0	0	0	0	0	0	0	
Green	Green(0)	0	0	0	0	0	0	0	0	0	0	0	0	0	0	0	0	0	0
	Green(1)	0	0	0	0	0	0	0	0	0	0	0	1	0	0	0	0	0	0
	Green(2)	0	0	0	0	0	0	0	0	0	0	1	0	0	0	0	0	0	0
	Green(62)	0	0	0	0	0	0	1	1	1	1	1	0	0	0	0	0	0	0
Green(63)	0	0	0	0	0	0	1	1	1	1	1	1	0	0	0	0	0	0	
Blue	Blue(0)	0	0	0	0	0	0	0	0	0	0	0	0	0	0	0	0	0	0
	Blue(1)	0	0	0	0	0	0	0	0	0	0	0	0	0	0	0	0	0	1
	Blue(2)	0	0	0	0	0	0	0	0	0	0	0	0	0	0	0	0	1	0
	Blue(62)	0	0	0	0	0	0	0	0	0	0	0	0	1	1	1	1	1	0
Blue(63)	0	0	0	0	0	0	0	0	0	0	0	0	1	1	1	1	1	1	

[Note]

*1) Definition of gray scale:

Color (n): n indicates gray scale level; larger n means brighter level.

*2) Data: 1-High, 0-Low.

6. BLOCK DIAGRAM

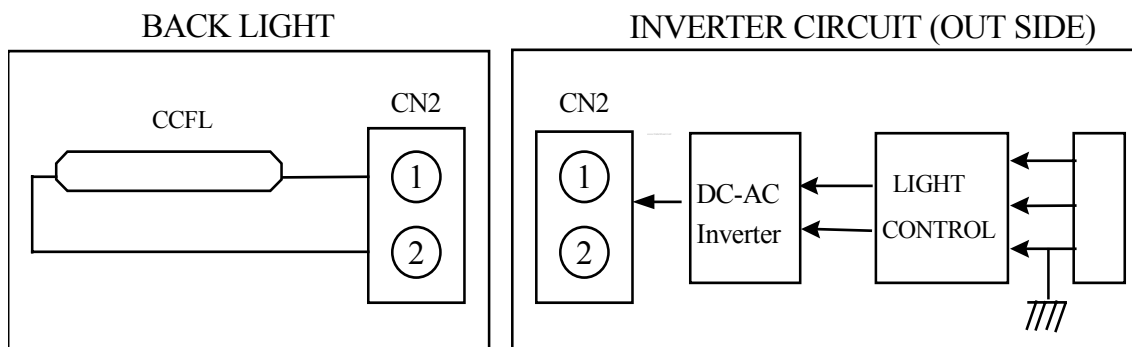
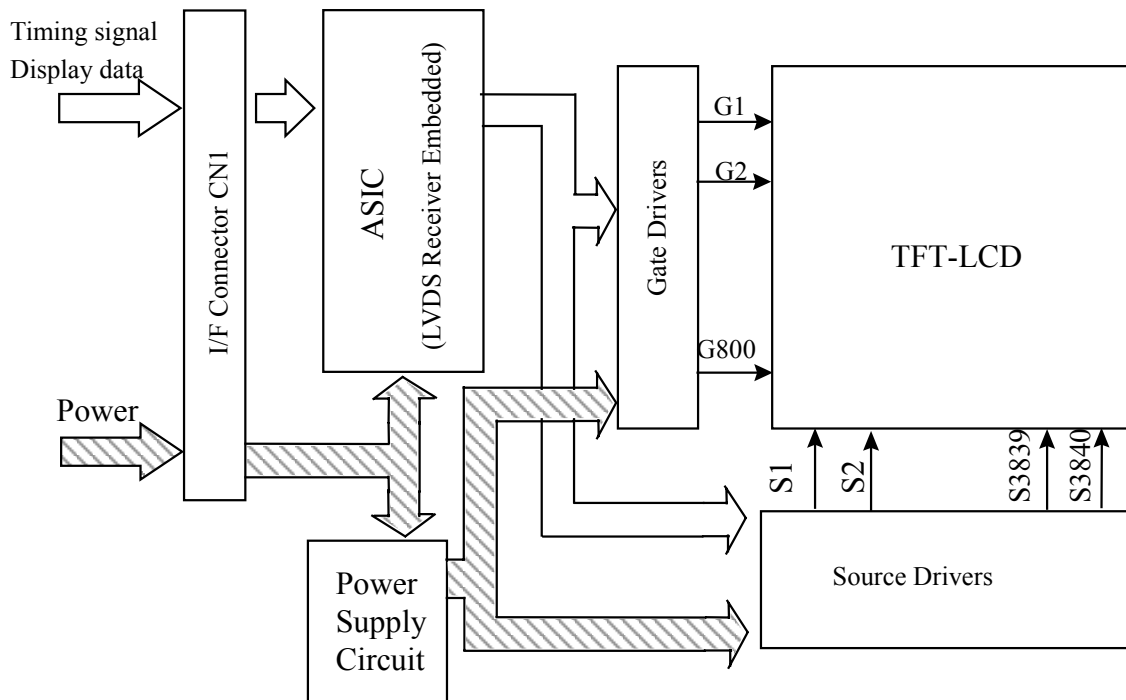

7. MECHANICAL SPECIFICATION

7.1 Front side (Tolerance is ± 0.5mm unless noted)

[Unit: mm]

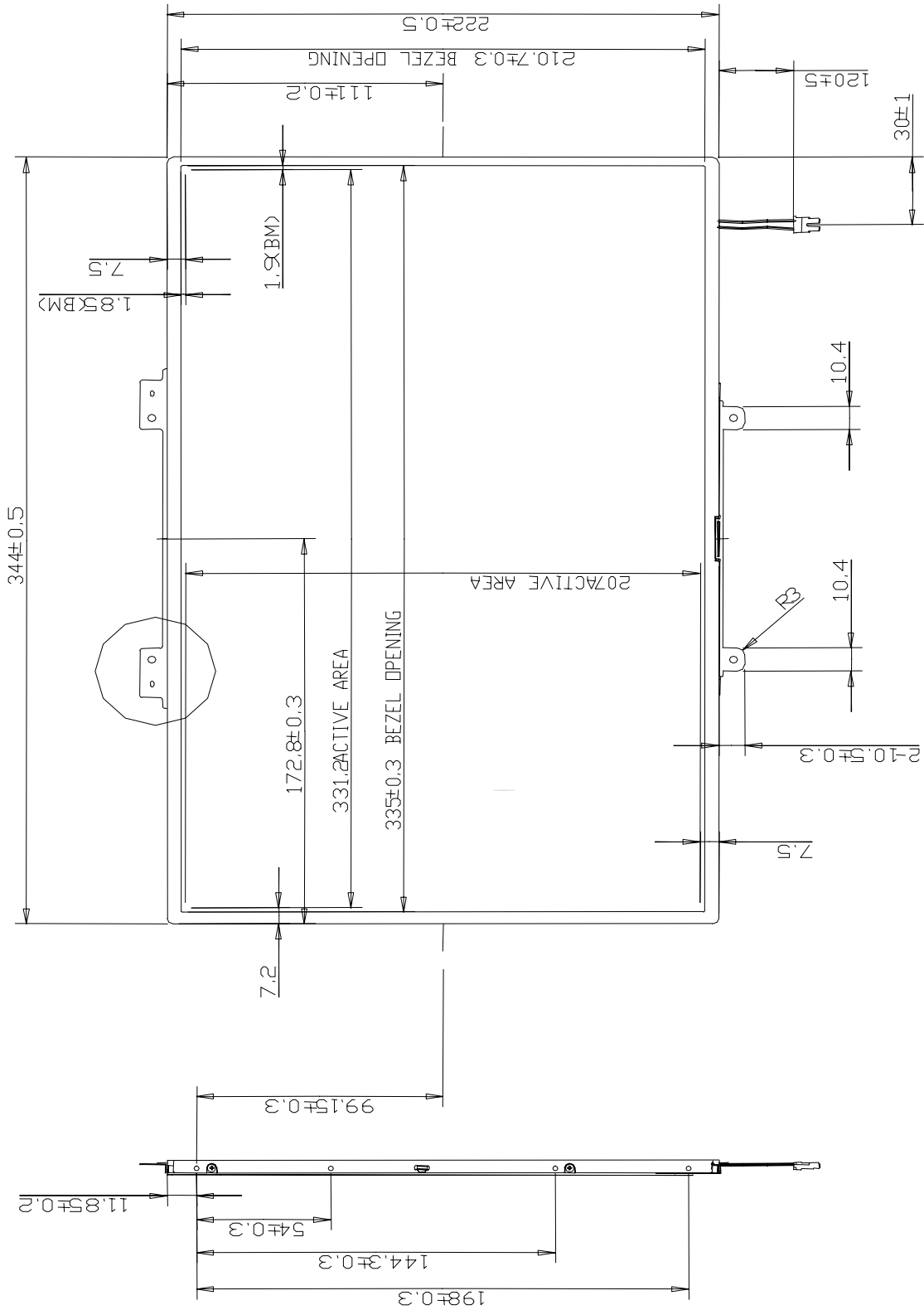

7.2 Rear side (Tolerance is ±0.5mm unless noted)

[Unit: mm]

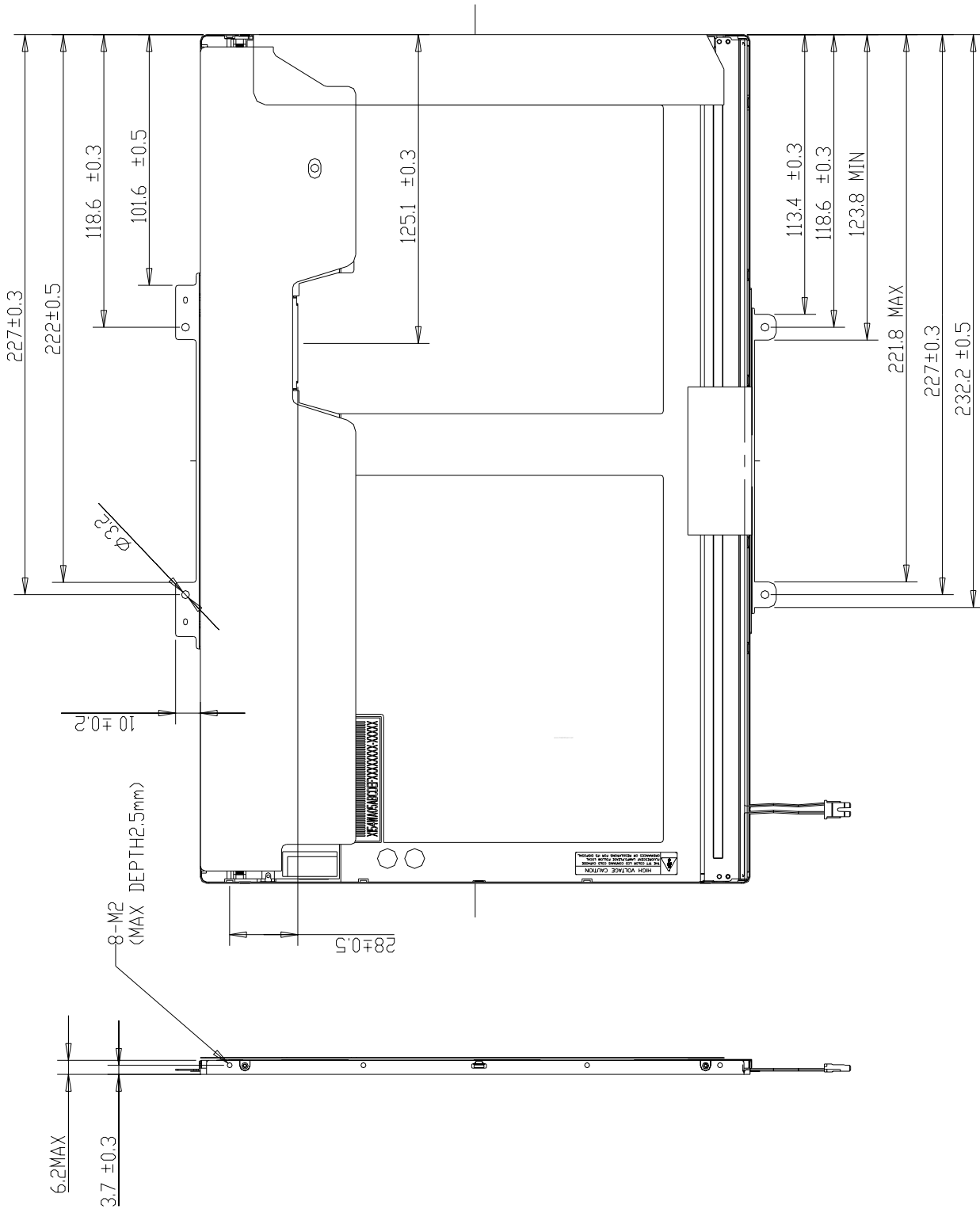

8.OPTICAL CHARACTERISTICS

Ta = 25°C, VCC=5.0V

ITEM	SYMBOL	CONDITION	MIN.	TYP.	MAX.	UNIT	REMARK	
Contrast (CEN)	CR	$\theta = \phi = 0^\circ$	300	500	--	--	*1)	
Luminance (CEN)	L	$\theta = \phi = 0^\circ$	170	190	--	cd/m ²	*2)	
5P Luminance (AVG)	L	$\theta = \phi = 0^\circ$	150	170	--	cd/m ²	*2)	
5P Uniformity	ΔL	$\theta = \phi = 0^\circ$	75	80	--	%	*2)	
Response Time	Tr	$\theta = \phi = 0^\circ$	--	9	12	ms	*4)	
	Tf	$\theta = \phi = 0^\circ$	--	16	23	ms		
Image sticking	Tis	2 hours	--	--	2	sec	*5)	
Cross talk ratio	CMR	--	--	--	1	%	*7)	
View angle	Horizontal	ϕ	CR \geq 10	-35 ~ +35	-40 ~ +40	--	Deg.	*3)
	Vertical	θ		-35 ~ +15	-40 ~ +20	--	Deg.	
Color Coordinates	White	X	$\theta = \phi = 0^\circ$	0.283	0.313	0.343	--	--
		Y		0.299	0.329	0.359		
	Red	X		0.587	0.617	0.647		
		Y		0.304	0.334	0.364		
Green	X	0.283	0.313	0.343				
	Y	0.529	0.559	0.589				
Blue	X	0.123	0.153	0.183				
	Y	0.098	0.128	0.158				
Gamut	--	--	45	50	--	%	--	
Gamma	γ	GL(8~55)	2.1	2.3	2.5	--	*6)	

[Note]

These items are measured using BM-5A (TOPCON) under the dark room condition (no ambient light).

Measurement Condition: IL=6.0mA

Inverter: SUMIDA / IV11145T.

Definition of these measurement items is as follows:

*1) Definition of Contrast Ratio

CR=ON (White) Luminance/OFF (Black) Luminance

*2) Definition of Luminance and Luminance uniformity

Central luminance: The white luminance is measured at the center position “5” on the screen, see Fig.1 below.

5P Luminance (AVG): The white luminance is measured at measuring points 1,2,3,4,5.

5P Uniformity: $\Delta L = (L_{MIN} / L_{MAX}) \times 100\%$

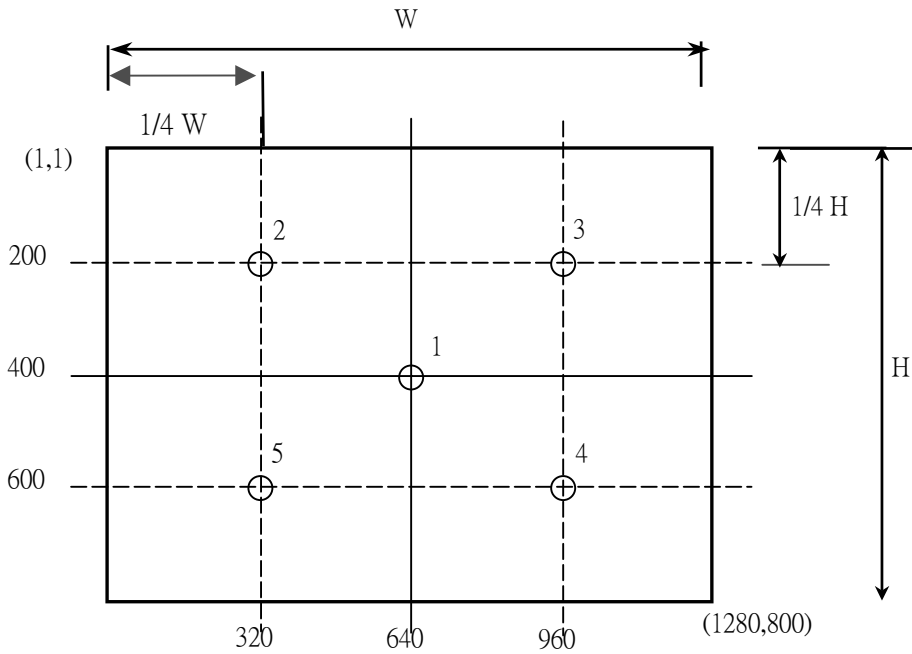

*3) Definition of Viewing Angle(θ, ϕ)

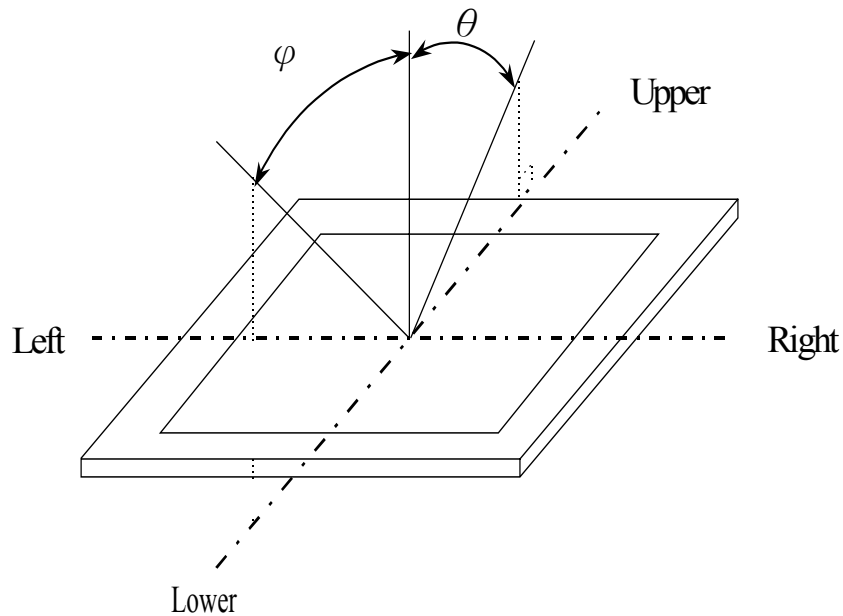

*4) Definition of Response Time

Change the module frame to Black/white pattern and use Westar TDR-100 to measure t_r and t_f at room temperature (25°C) .

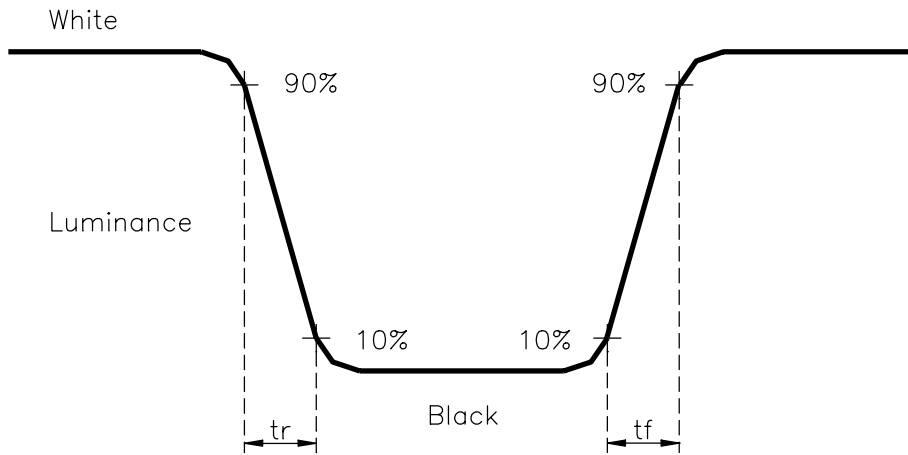

*5) Image sticking:

Continuously display the test pattern shown in the figure below for two-hours. Then switch to full white screen. It changes from test pattern to white pattern. The previous image should not persist more than two seconds at 25°C.

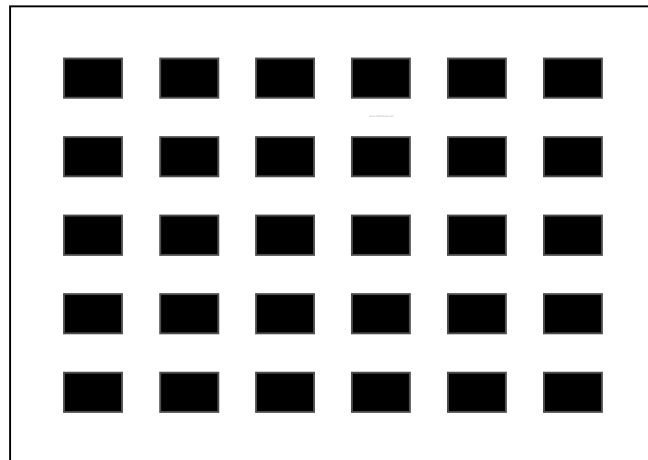

*6) Based on Customer Sample, take the average value as a standard center value and the variation range of Gamma value caused by loop voltage error should be between +/- 0.2. the bellow figure shows how to obtain the gamma curve and γ (from gray level 8~55)

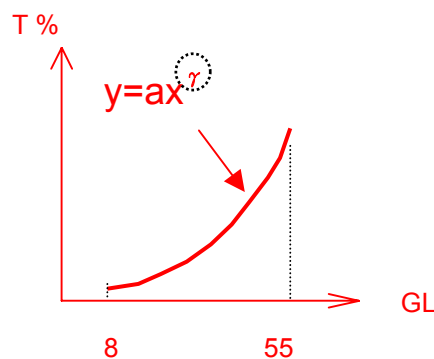

*7) Cross talk Modulation Ratio:

$$CT = | Y_B - Y_A | / Y_A \times 100\%$$

Y_A 、 Y_B measure position and definition

Y_A means luminance at gray level 32 (exclude gray level 0 pattern)

Y_B means luminance at gray level 32 (include gray level 0 pattern)

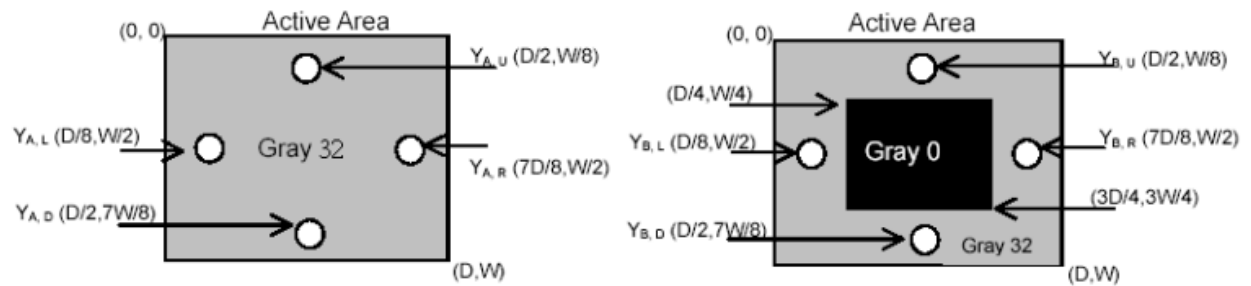

9.RELIABILITY TEST CONDITIONS

(1)Temperature and Humidity

TEST ITEMS	CONDITIONS
High Temperature High Humidity Operation	50°C ; 90%RH; 240hrs (No condensation)
High Temperature High Humidity Storage	60°C ; 90%RH; 48hrs (No condensation)
High Temperature Operation	50°C ; 240hrs
High Temperature Storage	60°C ; 240hrs
Low Temperature Operation	0°C ; 240hrs
Low Temperature Storage	-20°C ; 240hrs
Thermal Shock	Between -20°C (1hr) and 60°C (1hr);100 Cycles

(2) Shock & Vibration

ITEMS	CONDITIONS
Shock (Non-Operation)	Shock level: 1980m/s ² (200G) Waveform: half sinusoidal wave, 2ms Number of shocks: one shock input in each direction of three mutually perpendicular axes for a total of six shock inputs (±X, ±Y, ±Z)
Vibration (Non-Operation)	Vibration level: 14.7m/s ² (1.5G) zero to peak Waveform: sinusoidal wave Frequency range: 5 to 500 Hz Frequency sweep rate: 0.5 octave/min Duration: one sweep from 5 to 500Hz in each of three mutually perpendicular axis(each x,y,z axis: 1 hour, total 3 hours)

(3)ESD test

Test Item	Test statements
Connector	200 pF , 0 Ω , ±250 V By using contact-mode to discharge each pin one time and then check the module frame.
module	150pF , 330Ω , ±15KV 1.Under test conditions, by using air-mode to discharge each test point 25 times continuously and then check the module frame. 2. Under test conditions, by using contact-mode to discharge each test point of panel frame 25 times continuously and then check the module frame.

(4) Judgment standard

The judgment of the above test should be made as follow:

Pass: Normal display image with no obvious non-uniformity and no line defect.

Partial transformation of the module parts should be ignored.

Fail: No display image, obvious non-uniformity, or line defects.

10. HANDLING PRECAUTIONS FOR TFT-LCD MODULE

Please pay attention to the followings in handling- TFT-LCD products;

10.1 ASSEMBLY PRECAUTION

- (1) Please use the mounting hole on the module side in installing and do not beading or wrenching LCD in assembling. And please do not drop, bend or twist LCD module in handling.
- (2) Please design display housing in accordance with the following guidelines.
 - Housing case must be destined carefully so as not to put stresses on LCD all sides and not to wrench module. The stresses may cause non-uniformity even if there is no non-uniformity statically.
 - Keep sufficient clearance between LCD module back surface and housing when the LCD module is mounted. Approximately 1.0 mm of the clearance in the design is recommended taking into account the tolerance of LCD module thickness and mounting structure height on the housing.
 - When some parts, such as, FPC cable and ferrite plate, are installed underneath the LCD module, still sufficient clearance is required, such as 0.5mm. This clearance is, especially, to be reconsidered when the additional parts are implemented for EMI countermeasure.
 - Design the inverter location and connector position carefully so as not to give stress to lamp cable, or not to interface the LCD module by the lamp cable.
 - Keep sufficient clearance between LCD module and the others parts, such as inverter and speaker so as not to interface the LCD module. Approximately 1.0mm of the clearance in the design is recommended.
- (3) Please do not push or scratch LCD panel surface with any-thing hard. And do not soil LCD panel surface by touching with bare hands. (Polarizer film, surface of LCD panel is easy to be flawed.)
- (4) Please do not press any parts on the rear side such as source TCP, gate TCP, control circuit board and FPCs during handling LCD module. If pressing rear part is unavoidable, handle the LCD module with care not to damage them.
- (5) Please wipe out LCD panel surface with absorbent cotton or soft clothe in case of it being soiled.
- (6) Please wipe out drops of adhesives like saliva and water on LCD panel surface immediately. They might damage to cause panel surface variation and color change.
- (7) Please do not take a LCD module to pieces and reconstruct it. Resolving and reconstructing modules may cause them not to work well.
- (8) Please do not touch metal frames with bare hands and soiled gloves. A color change of the metal frames can happen during a long preservation of soiled LCD modules.
- (9) Please pay attention to handling lead wire of backlight so that it is not tugged in connecting with inverter.

10.2 OPERATING PRECAUTIONS

- (1) Please be sure to turn off the power supply before connecting and disconnecting signal input cable.
- (2) Please do not change variable resistance settings in LCD module. They are adjusted to the most suitable value. If they are changed, it might happen LCD does not satisfy the characteristics specification.
- (3) Please consider that LCD backlight takes longer time to become stable of radiation characteristics in low temperature than in room temperature.
- (4) A condensation might happen on the surface and inside of LCD module in case of sudden change of ambient temperature.
- (5) Please pay attention to displaying the same pattern for very long time. Image might stick on LCD. If then, time going on can make LCD work well.
- (6) Please obey the same caution descriptions as ones that need to pay attention to ordinary electronic parts.

10.3 PRECAUTIONS WITH ELECTROSTATICS

- (1) This LCD module use CMOS-IC on circuit board and TFT-LCD panel, and so it is easy to be affected by electrostatics. Please be careful with electrostatics by the way of your body connecting to the ground and so on.
- (2) Please remove protection film very slowly on the surface of LCD module to prevent from electrostatics occurrence.

10.4 STORAGE PRECAUTIONS

- (1) When you store LCDs for a long time, it is recommended to keep the temperature between 0°C ~40°C without the exposure of sunlight and to keep the humidity less than 90%RH.
- (2) Please do not leave the LCDs in the environment of high humidity and high temperature such as 60°C and 90%RH.
- (3) Please do not leave the LCDs in the environment of low temperature(below -20°C.)

10.5 SAFETY PRECAUTIONS

- (1) When you waste LCDs, it is recommended to crush damaged or unnecessary LCDs into pieces and wash them off with solvents such as acetone and ethanol, which should later be burned.
- (2) If any liquid leaks out of a damaged-glass cell and comes in contact with the hands, wash off thoroughly with soap and water.

10.6 OTHERS

- (1) A strong incident light into LCD panel might cause display characteristic changing inferior because of polarizer film, color filter, and other materials becoming inferior. Please do not expose LCD module direct sunlight and strong UV rays.
- (2) Please pay attention to a panel side of LCD module not to contact with other materials in preserving it alone.
- (3) For the packaging box, please pay attention to the followings:
 - Packaging box and inner case for LCD are designed to protect the LCDs from the damage or scratching during transportation. Please do not open except picking LCDs up from the box.
 - Please do not pile them up more than 3 boxes. (They are not designed so.) And please do not turn over.
 - Please handle packaging box with care not to give them sudden shock and vibrations. And also please do not throw them up.
 - Packing box and inner case for LCDs are made of cardboard. So please pay attention not to get them wet. (Such like keeping them in high humidity or wet place can occur getting them wet.)