



Chunghwa Picture Tubes, Ltd.

Technical Specification

To : **ECS**
Date : **2008/08/25**

TFT LCD
CLAA154WB03AN

ACCEPTED BY :

APPROVED BY	CHECKED BY	PREPARED BY
黃奕凱	劉益群	趙志方

Prepared by : TFT-LCD Product Planning Management Division

CHUNGHWA PICTUER TUBES, LTD.

1127 Hopin Rd., Padeh, Taoyuan, Taiwan 334, R.O.C.
TEL: +886-3-3675151 FAX: +886-3-377-3001

Doc.No:	CLAA154WB03AN-ECS-V1-2008/08/25	Issue Date:	2008/08/25
---------	---------------------------------	-------------	------------

RECORD OF REVISIONS

Revision No.	Date	Description
V1	2008/08/25	final edition

1. OVERVIEW

CLAA154WB03AN is 15.4" color (39.116cm) TFT-LCD (Thin Film Transistor Liquid Crystal Display) module composed of LCD panel, LVDS driver ICs, control circuit and backlight. By applying 6 bit digital data, 1280×RGB (3) ×800, 262K-color images are displayed on the 15.4" diagonal screen. general specifications are summarized in the following table :

ITEM	SPECIFICATION
Display Area (mm)	331.2 (H)×207.0 (V) (15.4-inch diagonal)
Number of Pixels	1280 ×3(H)×800(V)
Pixel Pitch (mm)	0.25875(H)×0.25875(V)
Color Pixel Arrangement	RGB vertical stripe
Display Mode	Normally white
Number of Colors	262,144(6bits)(RSDS)
Gamut	45%(typ)
Optimum Viewing Angle	6 o'clock
Response Time (ms)	8ms
Viewing Angle	40°、40° /10°、30°(Min.)
Brightness (cd/m ²)	220 cd/m ² (5point)/6 mA (Typ.)
Uniformity	5point : 80%(Typ.)
Consumption of Power (W)	6.3W (Max)
Module Size (mm)	344.5(W)×222.5(H)×6.2(D) (Max)
Module Weight (g)	500(Typ.)
Surface Treatment	Glare type (3H)

The LCD Products listed on this document are not suitable for use of aerospace equipment, submarine cable, and nuclear reactor control system and life support systems. If customers intend to use these LCD products for applications listed above or those not included in the "Standard" list as follows, please contact our sales in advance.

Standard : Computer, Office equipment, Communication equipment, Test and Measurement equipment, Machine tool, Industrial robot, Audio and Visual equipment, Other consumer products.

2. ABSOLUTE MAXIMUM RATINGS

The following are maximum value, which if exceeded, may cause faulty operation or damage to the unit.

ITEM	SYMBOL	MIN.	MAX.	UNIT	REMARK
Power Supply Voltage for LCD	VCC	0	4.0	V	
Lamp voltage	VL	630	900	Vrms	
Lamp current	IL	2	6.5	mA rms	*1). 2)
Lamp frequency	FL	40	80	kHz	
Operation Temperature	Top	0	50	°C	*3). 4). 5). 6)
Storage Temperature	Tstg	-25	65	°C	*3). 4). 5)
Delayed Discharge Time	TD	--	1	sec	*7)

【Note】

- *1) Product life-time relate to lamp current, please operate production follow statement at page 9 “(b)back light”.
- *2) When lamp current over the definition of absolute max, product life-time will decay rapidly or operate unusual.
- *3) The relative temperature and humidity range are as below sketch, 90%RH Max. ($T_a \leq 40^\circ\text{C}$)
- *4) The maximum wet bulb temperature $\leq 39^\circ\text{C}$ ($T_a > 40^\circ\text{C}$) and without dewing.
- *5) If product in environment which over the definition of the relative temperature and humidity out of range too long, it will affect visual of LCD.
- *6) If you operate LCD in normal temperature range, the center surface of panel should be under 60°C .
- *7) Delay discharge time test condition : Starting lamp voltage=1650Vrms. (please follow statement at page 9 “ (b) back light”

Before test TD, lamp should operate at least 1min, and lamp current should follow typical lamp current specification. To place panel at room temp. ($25 \pm 2^\circ\text{C}$) below for 24hrs, and then to measure TD with the same starting lamp voltage in dark room.

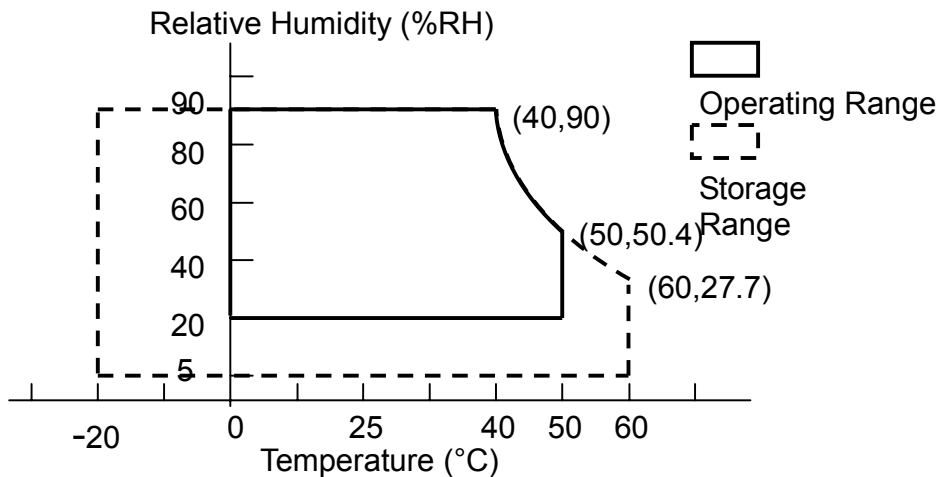

3. ELECTRICAL CHARACTERISTICS

3.1 TFT LCD

Ta=25°C

TEM	SYMBOL	MIN	TYP	MAX	UNIT	REMARK	
LCD POWER VOLTAGE	VCC	3.0	3.3	3.6	V	[Note 1]	
LCD POWER CURRENT	ICC	-	400	600	mA	[Note 2]	
Rush CRRENT	Irush	-	-	2	A	[Note 4]	
LOGIC INPUT VOLTAGE (LVDS: IN+,IN-) [Note 3]	INPUT VOLTAGE	VIN	0	-	VCC	V	
	COMMON VOLTAGE	VCM	1.125	1.25	1.375	V	
	DIFFERENTIAL INPUT VOLTAGE	VID	250	350	450	mV	
	THRESHOLD VOLTAGE (HIGH)	VTH	-	-	100	mV	When VCM = +1.2V
	THRESHOLD VOLTAGE (LOW)	VTL	-100	-	-	mV	
DIFFERENTIAL INPUT VOLTAGE TOLERANCE	ΔVID	-	-	35	mV		
COMMON VOLTAGE TOLERANCE	ΔVCM	-	-	35	mV		

[Note 1] Power Sequence :

- t1 ≤ 10ms
- 0.01 ms < t2 ≤ 50 ms
- 0.01 ms < t3 ≤ 50 ms
- 1 sec ≤ t4
- 200 ms ≤ t5
- 200 ms ≤ t6

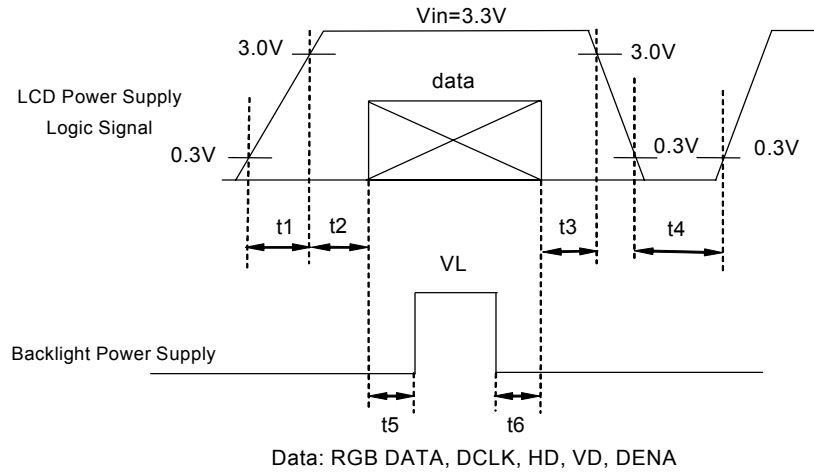

VCC-dip state

(1)when $3.0 > VCC \geq 2.7V$, $t_d \leq 10$ ms

(2)when $VCC < 2.7V$, VCC-dip condition should as the VCC-turn-off condition.

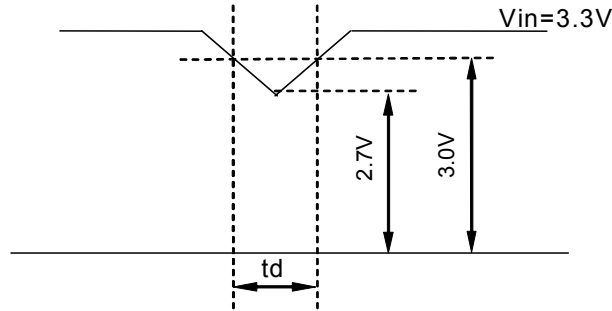

[Note 2]

Typical value is 0~63 gray level.(Horizontal line Pattern)

800 line mode , VCC= +3.3V

Circuit condition (Typ.)

VCC=3.3 V , fv=60 Hz fh=48.9 kHz , fclk=68.9 MHz

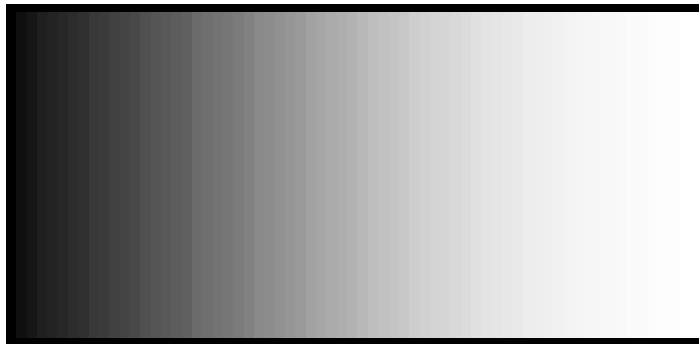

64-Gray:
0 ~ 63 Gray

Circuit condition (MAX.)

VCC=3.3 V , fv=60 Hz fh=48.9 kHz , fclk=68.9 MHz

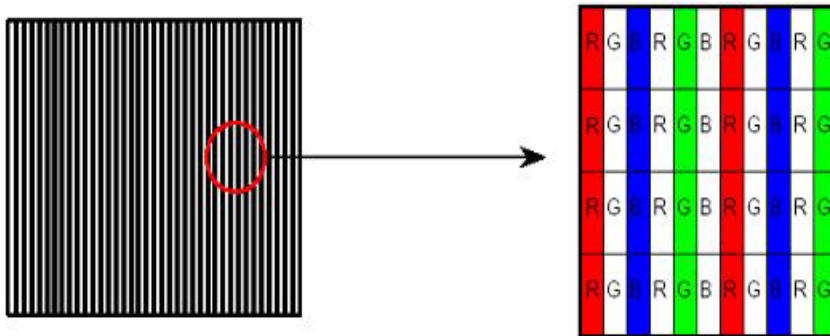

[Note 3]
 LVDS Signal Definite :

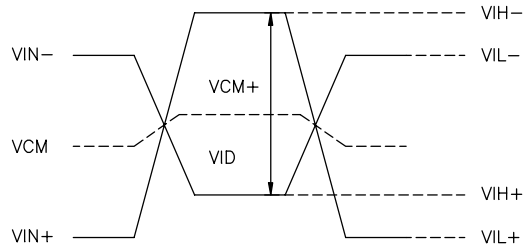
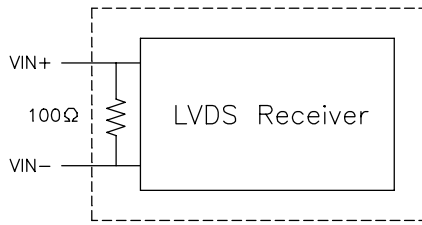

$$\begin{aligned}
 VID &= VIN_+ - VIN_-, \\
 \Delta VCM &= | VCM_+ - VCM_- |, \\
 \Delta VID &= | VID_+ - VID_- |, \\
 VID_+ &= | VIH_+ - VIL_+ |, \\
 VID_- &= | VIL_+ - VIL_- |, \\
 VCM &= (VIN_+ + VIN_-)/2, \\
 VCM_+ &= (VIH_+ + VIH_-)/2, \\
 VCM_- &= (VIL_+ + VIL_-)/2,
 \end{aligned}$$

VIN+ : Positive differential DATA & CLK Input
 VIN- : Negative differential DATA & CLK Input

4) Refer to Inverter rated voltage
 [Note 4] Irush measure condition

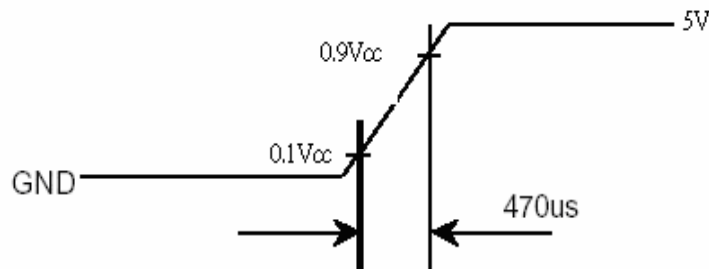
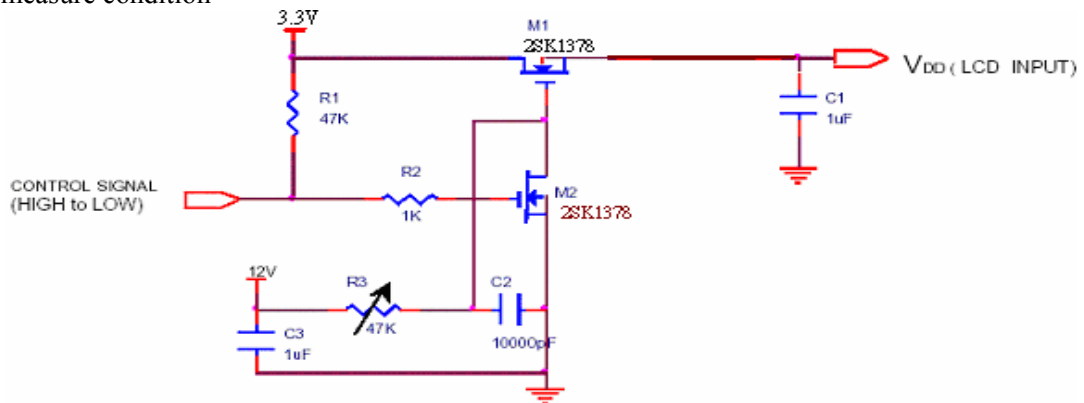

3.2 Back light*1)

3.2.1 Electrical characteristics :

Ta=25°C

ITEM	SYMBOL	MIN	TYP	MAX	UNIT	REMARK
Lamp Voltage(IL=6.0mA)	VL	630	700	770	Vrms	IL=6.0mA
Lamp Current	IL	5.5	6.0	6.5	mArms	*1)
Inverter Frequency	FI	40	--	60	kHz	*2)
Lamp Initial Voltage	VS	1330	--		Vrms	Ta=25°C
		1730	--		Vrms	Ta=0°C

3.2.2 Lamp life time

ITEM	IL at 2.0 mA	IL at 6.0 mA	IL at 6.5 mA	單位	備註
LAMP LIFE-TIME (LT)	Min. 15,000	Min. 15,000	Min.10,000	hr	Continuous Operation*3)
Turn-on and turn-off Operation	--	Min.100,000	--	times	Continuous Operation *4)

【Note】

*1) Measure method : Galvanometer connect to low voltage

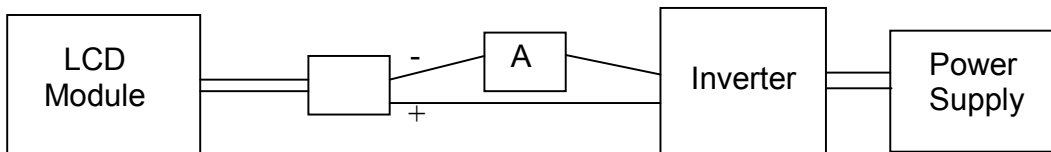

*2) Frequency in this range can make the characteristics of electric and optics maintain in +/- 10% except hue. Lamp frequency of inverter may produce interference with horizontal synchronous frequency, and this may cause horizontal beat on the display. Therefore, please adjust lamp frequency, and keep inverter as far from module as possible or use electronic shielding between inverter and module to avoid the interference. Under optimum operate frequency range (50~80 KHz), will not effect panel life-time and reliability .

*3) Definition of the lamp life time :

- a. Luminance (L) under 50% of specification starting lamp voltage
- b. Starting Lamp Voltage: over130% of the initial value. Ta=25°C

*4) For keeping good lighting situation, when design the inverter, it must be considered that the voltage large than starting lamp voltage.

*5) $WL=IL \times VL$ (IL=6mA , Ta=25°C)

4.Connector Interface PIN & Function *1)*2)

4.1 CN1(Interface signal)

Outlet connector: FI-XB30SL-HF10 (JAE)

Link connector: FI-X30H (JAE, Link Type)

Pin No.	SYMBOL	Function
1	V _{ss}	Ground
2	V _{in}	+3.3V
3	V _{in}	+3.3V
4	V _{EDID}	DDC 3.3V Power
5	NC	VCOM test provided , but customer-end unused (open)
6	CLK _{EDID}	DDC Clock
7	DATA _{EDID}	DDC Data
8	R _{0N}	minus signal of channel 0(LVDS)
9	R _{0P}	plus signal of channel 0(LVDS)
10	V _{ss}	Ground
11	R _{1N}	minus signal of channel 1(LVDS)
12	R _{1P}	plus signal of channel 1(LVDS)
13	V _{ss}	Ground
14	R _{2N}	minus signal of channel 2(LVDS)
15	R _{2P}	plus signal of channel 2(LVDS)
16	V _{ss}	Ground
17	RCLKN	minus signal of clock channel (LVDS)
18	RCLKP	plus signal of clock channel (LVDS)
19	V _{ss}	Ground
20	NC	No connect
21	NC	No connect
22	NC	No connect
23	NC	No connect
24	NC	No connect
25	NC	No connect
26	NC	No connect
27	NC	No connect
28	NC	No connect
29	NC	No connect
30	NC	No connect

【Note】

*1) DDC: Display Data Requirements

*2) Refer to Data Mapping of page 7,8,9.

4.2 CN2 (Back light)

Backlight-side connector: BHSR-02VS-1 (JST)

Inverter-side connector: SM02B-BHSS-1 (JST)

Pin No.	Symbol	Function
1	CTH	VBLH (High)
2	CTL	VBLL (Low)

[Note] : VBLH-VBLL=VL

5. INTERFACE TIMING CHART

5.1 LCD Input Signal Timing Chart

5.1.1 Horizontal Timing sequence

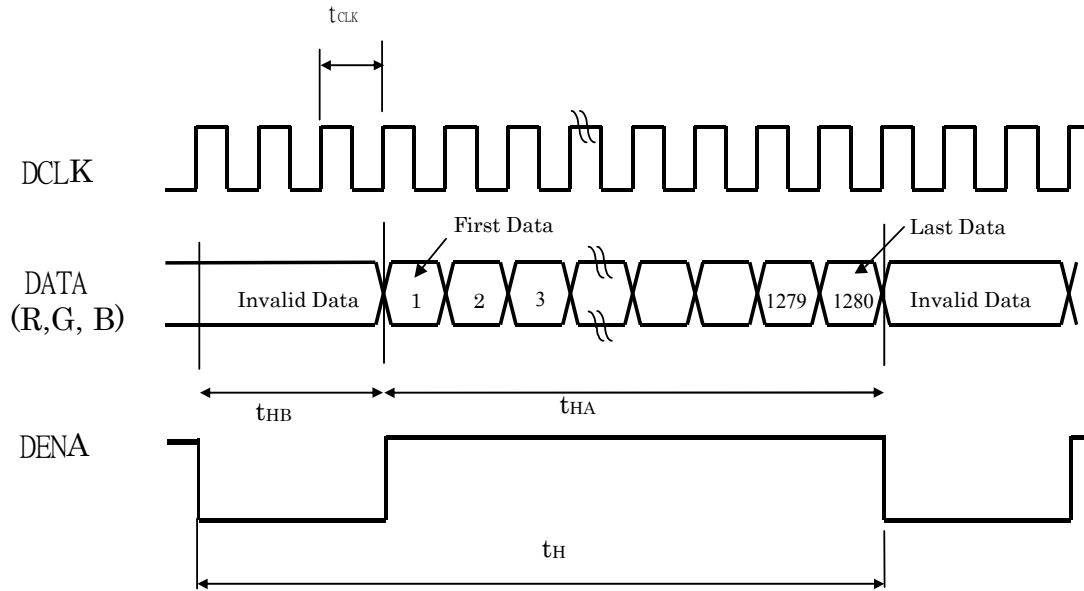

5.1.2 Vertical Timing sequence:

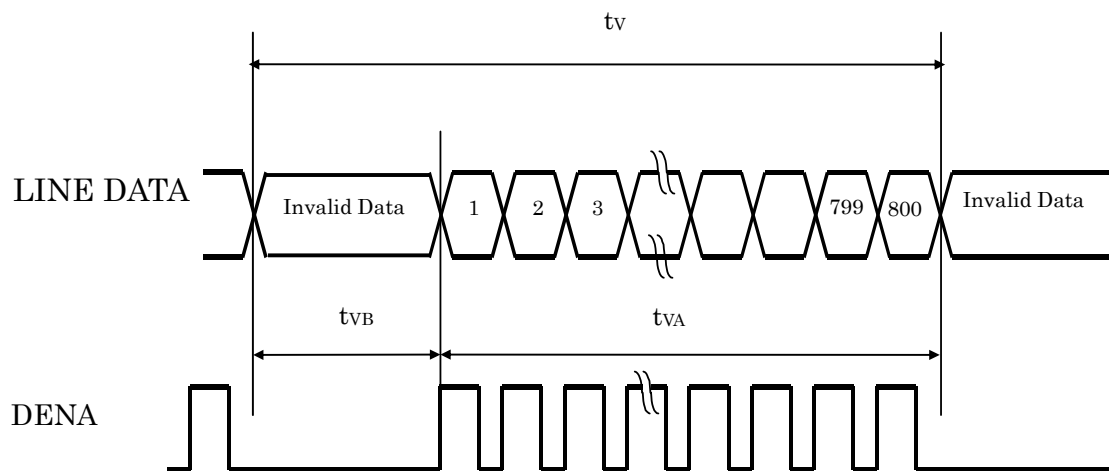

5.2 Timing Chart *1)*2)*3)

		ITEM	SYMBOL	MIN	TYP	MAX	UNIT
LCD input signal	DCLK	frequency	f_{CLK}	65.3	68.9	74.7	MHz
		period	t_{CLK}	15.3	14.5	13.3	ns
	DENA	Horizontal total Time	t_H	1344	1408	1500	t_{CLK}
		Horizontal Active Time	t_{HA}	1280	1280	1280	t_{CLK}
		Horizontal Blank Time	t_{HB}	64	128	220	t_{CLK}
		Vertical total Time	t_V	810	816	830	t_H
		Vertical Active Time	t_{VA}	800	800	800	t_H
		Vertical Blank Time	t_{VB}	10	16	30	t_H

【Note】

[Note]

*1) Data is latched during DCLK falling period.

*2) HD、VD is negative.

*3) DENA (DATA ENABLE) usually is positive.

*4) During the whole blank period, DCLK should keep input. During the vertical blank period, HD should keep input.

5.3 Color DATA Assignment

Color	Input Data	R DATA						G DATA						B DATA					
		R5	R4	R3	R2	R1	R0	G5	G4	G3	G2	G1	G0	B5	B4	B3	B2	B1	B0
		MS B					LS B	MS B					LS B	MS B					LS B
Basic Color	Black	0	0	0	0	0	0	0	0	0	0	0	0	0	0	0	0	0	0
	Red(63)	1	1	1	1	1	1	0	0	0	0	0	0	0	0	0	0	0	0
	Green(63)	0	0	0	0	0	0	1	1	1	1	1	1	0	0	0	0	0	0
	Blue(63)	0	0	0	0	0	0	0	0	0	0	0	0	1	1	1	1	1	1
	Cyan	0	0	0	0	0	0	1	1	1	1	1	1	1	1	1	1	1	1
	Magenta	1	1	1	1	1	1	0	0	0	0	0	0	1	1	1	1	1	1
	Yellow	1	1	1	1	1	1	1	1	1	1	1	1	0	0	0	0	0	0
	White	1	1	1	1	1	1	1	1	1	1	1	1	1	1	1	1	1	1
RED	RED(0)	0	0	0	0	0	0	0	0	0	0	0	0	0	0	0	0	0	0
	RED(1)	0	0	0	0	0	1	0	0	0	0	0	0	0	0	0	0	0	0
	RED(2)	0	0	0	0	1	0	0	0	0	0	0	0	0	0	0	0	0	0
	RED(62)	1	1	1	1	1	0	0	0	0	0	0	0	0	0	0	0	0	0
	RED(63)	1	1	1	1	1	1	0	0	0	0	0	0	0	0	0	0	0	0
Green	Green(0)	0	0	0	0	0	0	0	0	0	0	0	0	0	0	0	0	0	0
	Green(1)	0	0	0	0	0	0	0	0	0	0	0	1	0	0	0	0	0	0
	Green(2)	0	0	0	0	0	0	0	0	0	0	1	0	0	0	0	0	0	0
	Green(62)	0	0	0	0	0	0	1	1	1	1	1	0	0	0	0	0	0	0
	Green(63)	0	0	0	0	0	0	1	1	1	1	1	1	0	0	0	0	0	0
Blue	Blue(0)	0	0	0	0	0	0	0	0	0	0	0	0	0	0	0	0	0	0
	Blue(1)	0	0	0	0	0	0	0	0	0	0	0	0	0	0	0	0	0	1
	Blue(2)	0	0	0	0	0	0	0	0	0	0	0	0	0	0	0	0	1	0
	Blue(62)	0	0	0	0	0	0	0	0	0	0	0	0	1	1	1	1	1	0
	Blue(63)	0	0	0	0	0	0	0	0	0	0	0	0	1	1	1	1	1	1

【Note】

- (1) Definition of gray scale:
 Color(n) : n means level of gray scale .
 Larger n means brighter level.
- (2) Data : 1= High , 0 = Low

6. BLOCK DIAGRAM

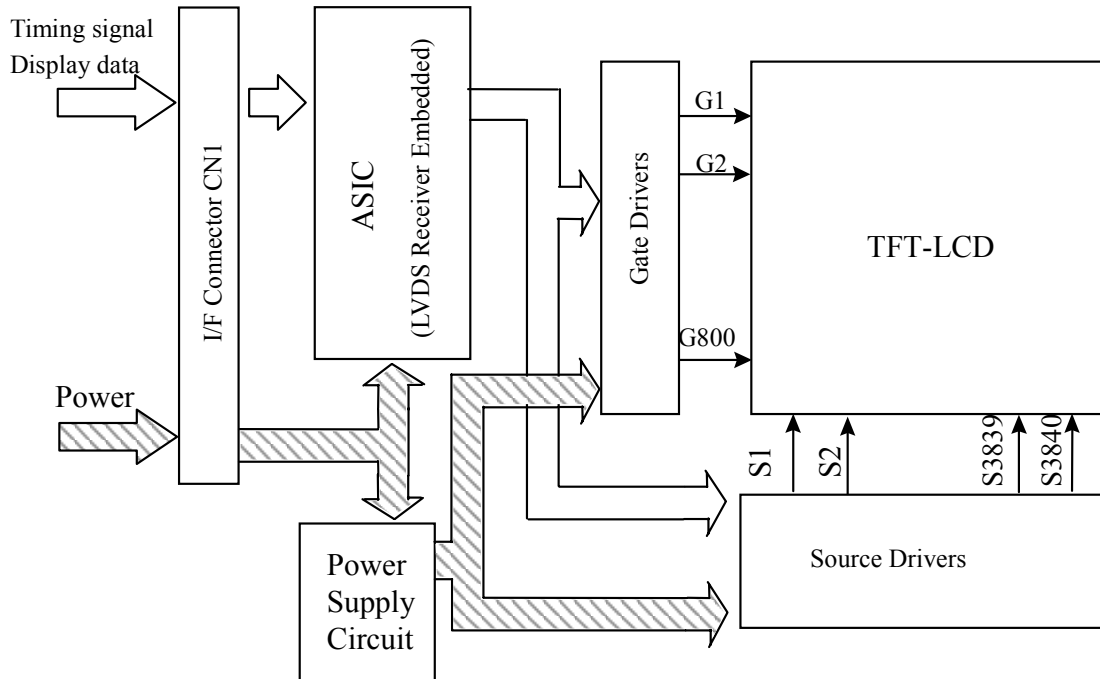

BACK LIGHT

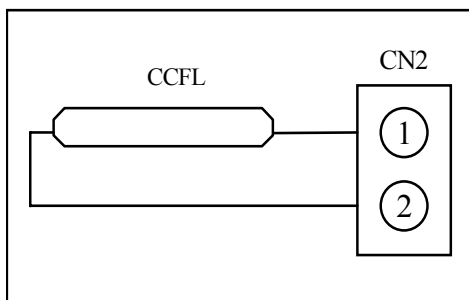

INVERTER CIRCUIT (OUT SIDE)

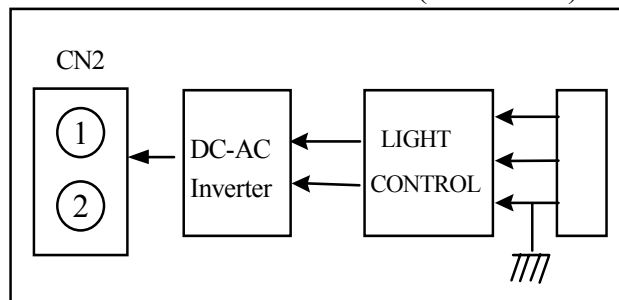

7.MECHANICAL SPECIFICATION

7.1 Front side

The tolerance, not show in the figure, is $\pm 0.5\text{mm}$.

[Unit : mm]

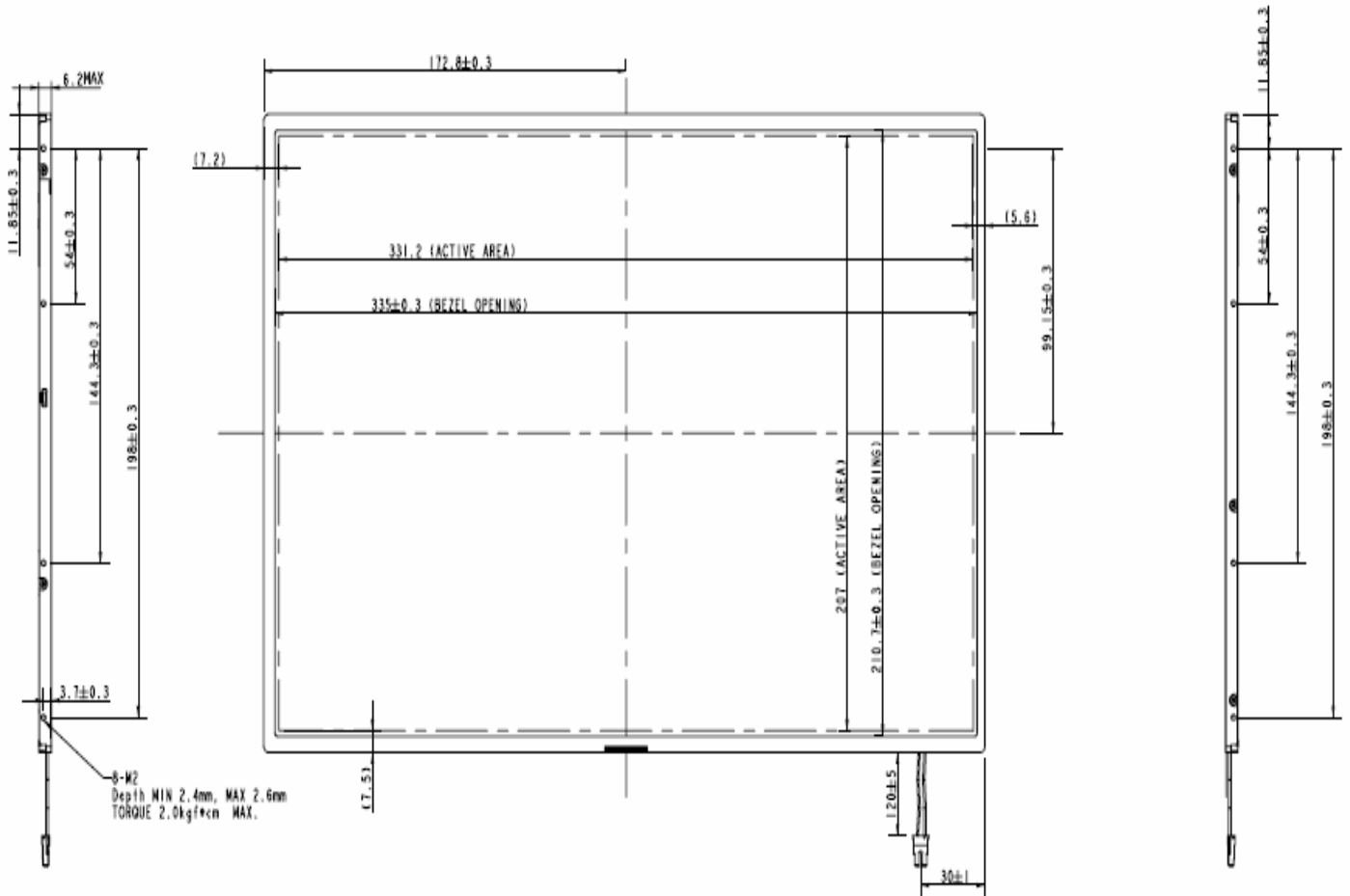

7.2 Rear side

Tolerance is $\pm 0.5\text{mm}$ unless noted

[Unit : mm]

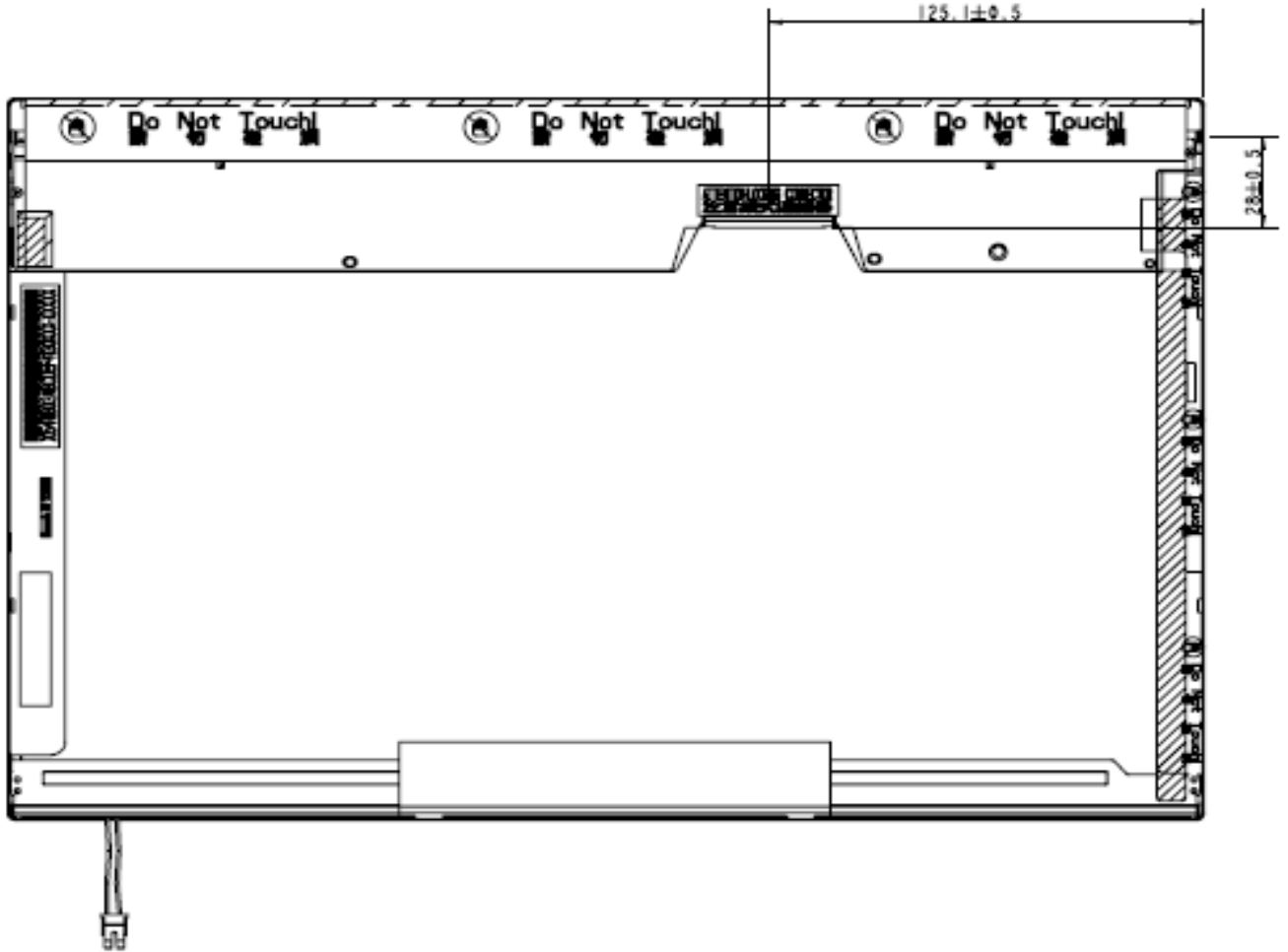

8. OPTICAL CHARACTERISTICS

Ta=25°C , VCC=3.3V

ITEM	SYMBOL	CONDITION	MIN.	TYP.	MAX.	UNIT	REMARK	
Contrast Ratio	CR	$\theta = \psi = 0^\circ$	400	600		--	*1)	
Luminance (5P)	L	$\theta = \psi = 0^\circ$	180	220		cd/m ²	*2)	
Uniformity(5P)	ΔL	$\theta = \psi = 0^\circ$		80		%	*2)	
Uniformity(13P)	ΔL	$\theta = \psi = 0^\circ$		72		%		
Response Time	Tr	$\theta = \psi = 0^\circ$		3	6	ms	*4)	
	Tf	$\theta = \psi = 0^\circ$		5	10	ms	*4)	
Cross talk	CT	$\theta = \phi = 0^{\circ*3}$			1	%	*5)	
View angle	Horizontal	Ψ	$CR \geq 10$	40/-40	45/-45		°	*3)
	Vertical	θ		10/-30	15/-35		°	*3)
Color Temperature Coordinate	W	X	$\theta = \psi = 0^\circ$	0.283	0.313	0.343		*2)
		Y		0.299	0.329	0.359		
	R	X		0.584	0.614	0.644		
		Y		0.306	0.336	0.366		
	G	X		0.281	0.311	0.341		
		Y		0.534	0.564	0.594		
	B	X		0.123	0.153	0.183		
		Y		0.100	0.130	0.160		
Gamut		$\theta = \psi = 0^\circ$		45%		%	*6)	

These items are measured using BM-5A (TOPCON) under the dark room condition (no ambient light).
Measurement Condition: IL=6.0×6mA

Inverter : SUMIDA / IV12139/T

Definition of these measurement items is as follows:

*1) Definition of Contrast Ratio

CR=ON (White) Luminance/OFF (Black) Luminance

***2) Definition of Luminance and Luminance uniformity**

Central luminance: The white luminance is measured at the center position "5" on the screen, see Fig.1 below.

5P Uniformity: $\Delta L = (L_{min} / L_{max}) \times 100\%$

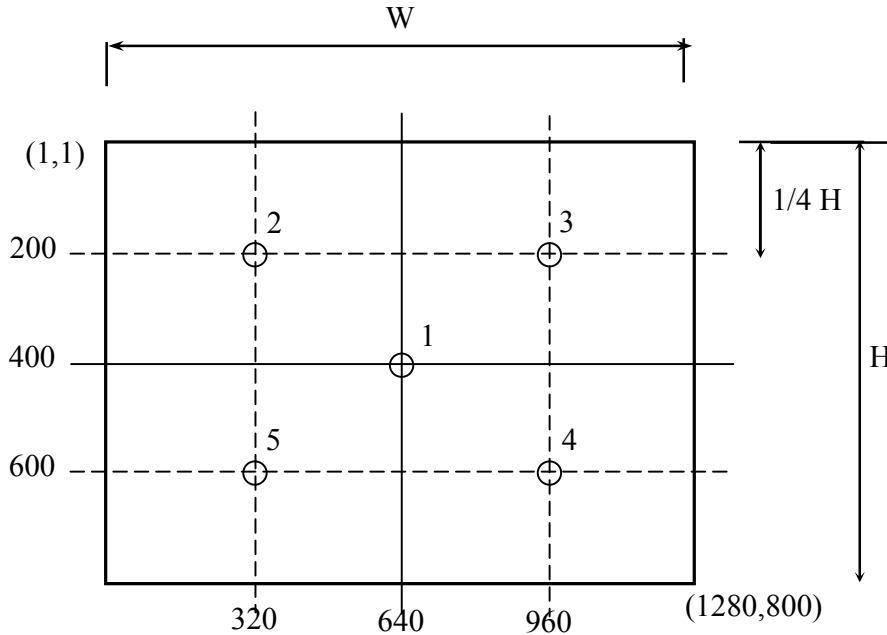
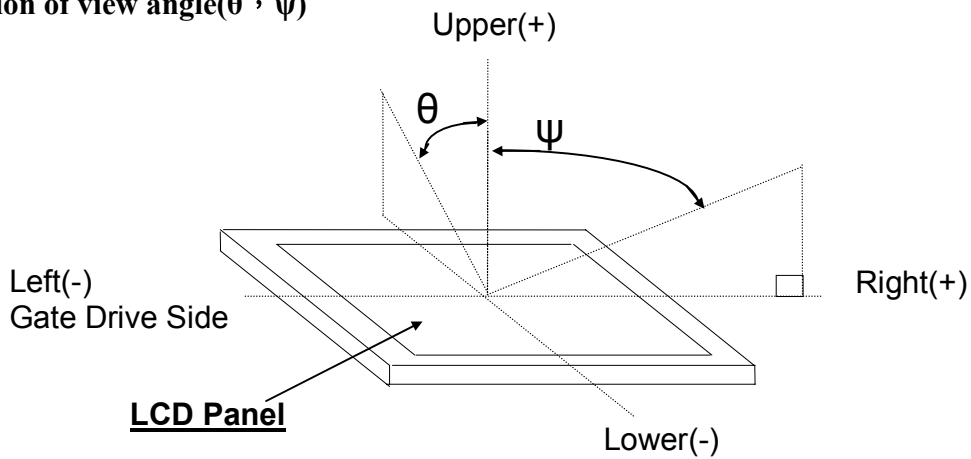
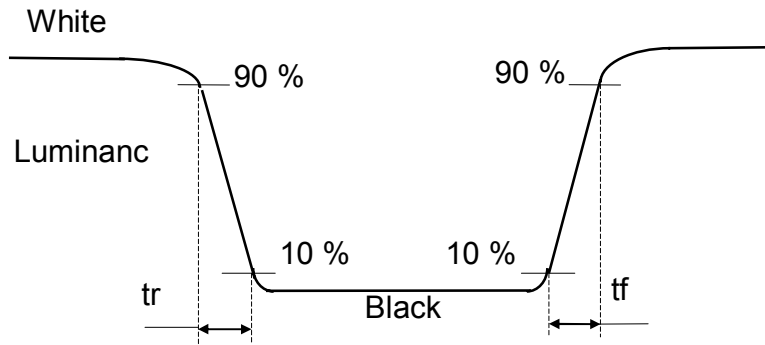

Fig.1 Measure

***3) Definition of view angle(θ , ψ)**



***4) Definition of response time**



***5) Crosstalk Modulation Ratio:**

$$CT = |Y_B - Y_A| / Y_A \times 100\%$$

Y_A 、 Y_B measure position and definition

Y_A means luminance at gray level 32(exclude gray level 0 pattern)

Y_B means luminance at gray level 32(include gray level 0 pattern)

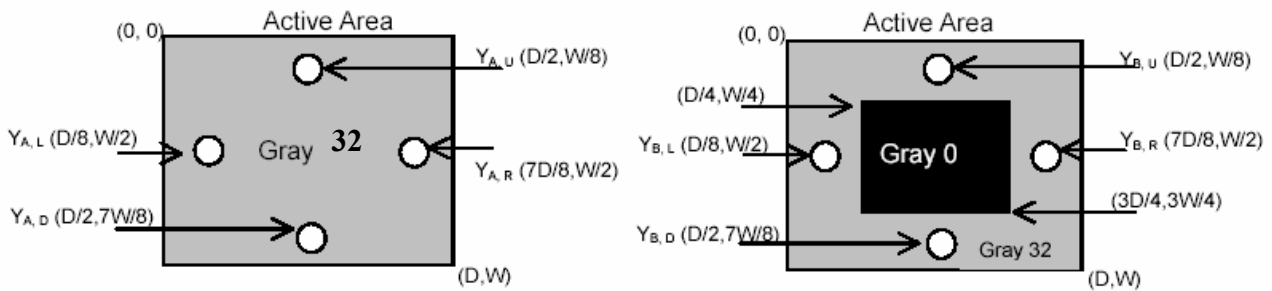

***6) Definition Gamma (VESA)**

Based on Customer Sample, take the average value as a standard center value and the variation range of Gamma value caused by loop voltage error should be between +/- 0.2. the bellow figure shows how to obtain the gamma curve and γ (from gray level: 0、16、32----224、240、255).

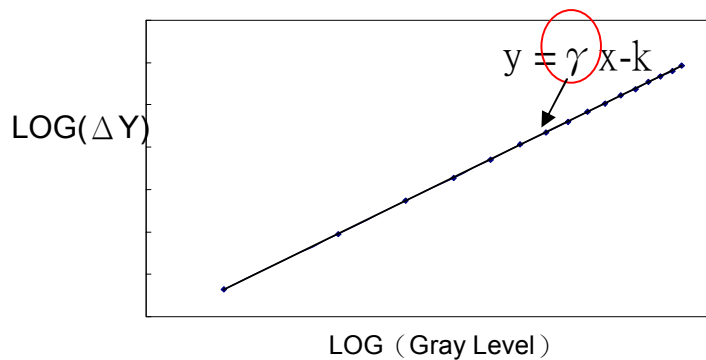

9.RELIABILITY TEST CONDITIONS

9.1 Temperature and Humidity

TEST ITEMS	CONDITIONS
High Temperature Operation	50° C ; 240Hrs
High Temperature Storage	60° C ; 240Hrs
High Temperature High Humidity Operation	50° C ; 90% RH ; 240Hrs
High Temperature High Humidity Storage	60° C ; 90% RH ; 48 Hrs
Low Temperature Operation	0° C ; 240 Hrs
Low Temperature Storage	-20° C ; 240 Hrs
Thermal Shock	-20° C (0.5 hr)~60° C (0.5 hr) , Ramp<20° C , 100 CYCLE

9.2 Shock & Vibration

TEST ITEMS	CONDITIONS
Shock (Non-Operation)	Shock level : 1960m/s ² (200G), Waveform : half sinusoidal wave, 2ms, 6 axis (± X,± Y,± Z) per cycle
Vibration (Non-Operation)	Vibration level : 9.8m/s ² (1.0G), sinusoidal wave (each x, y, z axis : 1hr, total 3hrs) Frequency range : 5~500 Hz Sweep speed : 0.5 Octave/min.

9.3 ESD test

Power on or off	Power off		Power on		
Test Position	Surface discharge(Panel display area、Frame、PWB、Panel back side)		Electric capacity of Connector	Surface discharge (Frame)	Surface discharge (Edge of panel)
Mode	Contact	Air	Contact	Contact	Air
Capacity	150 pF	150 pF	200 pF	150 pF	150 pF
Resistance	330 Ω	330 Ω	0 Ω	330 Ω	330 Ω
Voltage	±8kV/±15kV	±8kV/±15kV	±250 V	±6kV/±8kV	±8kV/±15kV
Interval	1 sec	1 sec	1 sec	1 sec	1 sec
Times(single point)	25	25	1	25	25

9.4 MTBF without B/L: 200,000 Hrs (min) lifetimes.

9.5 Judgment standard

The judgment of the above test should be made as follow:

Pass : Normal display image with no obvious non-uniformity and no line defect.

Partial transformation of the module parts should be ignored.

Fail : No display image, obvious non-uniformity, or line defects.

10. HANDLING PRECAUTIONS FOR TFT-LCD MODULE

Please pay attention to the followings in handling- TFT-LCD products;

10.1 ASSEMBLY PRECAUTION

- (1) Please use the mounting hole on the module side in installing and do not beading or wrenching LCD in assembling. And please do not drop, bend or twist LCD module in handling.
- (2) Please design display housing in accordance with the following guidelines.
 - Housing case must be destined carefully so as not to put stresses on LCD all sides and not to wrench module. The stresses may cause non-uniformity even if there is no non-uniformity statically.
 - Keep sufficient clearance between LCD module back surface and housing when the LCD module is mounted. Approximately 1.0 mm of the clearance in the design is recommended taking into account the tolerance of LCD module thickness and mounting structure height on the housing.
 - When some parts, such as, FPC cable and ferrite plate, are installed underneath the LCD module, still sufficient clearance is required, such as 0.5mm. This clearance is, especially, to be reconsidered when the additional parts are implemented for EMI countermeasure.
 - Design the inverter location and connector position carefully so as not to give stress to lamp cable, or not to interface the LCD module by the lamp cable.
 - Keep sufficient clearance between LCD module and the others parts, such as inverter and speaker so as not to interface the LCD module. Approximately 1.0mm of the clearance in the design is recommended.
- (3) Please do not push or scratch LCD panel surface with any-thing hard. And do not soil LCD panel surface by touching with bare hands. (Polarizer film, surface of LCD panel is easy to be flawed.)
- (4) Please do not press any parts on the rear side such as source TCP, gate TCP, control circuit board and FPCs during handling LCD module. If pressing rear part is unavoidable, handle the LCD module with care not to damage them.
- (5) Please wipe out LCD panel surface with absorbent cotton or soft clothe in case of it being soiled.
- (6) Please wipe out drops of adhesives like saliva and water on LCD panel surface immediately. They might damage to cause panel surface variation and color change.
- (7) Please do not take a LCD module to pieces and reconstruct it. Resolving and reconstructing modules may cause them not to work well.
- (8) Please do not touch metal frames with bare hands and soiled gloves. A color change of the metal frames can happen during a long preservation of soiled LCD modules.
- (9) Please pay attention to handling lead wire of backlight so that it is not tugged in connecting with inverter.

10.2 OPERATING PRECAUTIONS

- (1) Please be sure to turn off the power supply before connecting and disconnecting signal input cable.
- (2) Please do not change variable resistance settings in LCD module. They are adjusted to the most suitable value. If they are changed, it might happen LCD does not satisfy the characteristics specification.
- (3) Please consider that LCD backlight takes longer time to become stable of radiation characteristics in low temperature than in room temperature.

- (4) A condensation might happen on the surface and inside of LCD module in case of sudden change of ambient temperature.
- (5) Please pay attention to displaying the same pattern for very long time. Image might stick on LCD. If then, time going on can make LCD work well.
- (6) Please obey the same caution descriptions as ones that need to pay attention to ordinary electronic parts.

10.3 PRECAUTIONS WITH ELECTROSTATICS

- (1) This LCD module use CMOS-IC on circuit board and TFT-LCD panel, and so it is easy to be affected by electrostatics. Please be careful with electrostatics by the way of your body connecting to the ground and so on.
- (2) Please remove protection film very slowly on the surface of LCD module to prevent from electrostatics occurrence.

10.4 STORAGE PRECAUTIONS

- (1) When you store LCDs for a long time, it is recommended to keep the temperature between 0°C ~40°C without the exposure of sunlight and to keep the humidity less than 90%RH.
- (2) Please do not leave the LCDs in the environment of high humidity and high temperature such as 60°C and 90%RH.
- (3) Please do not leave the LCDs in the environment of low temperature(below -20°C.)

10.5 SAFETY PRECAUTIONS

- (1) When you waste LCDs, it is recommended to crush damaged or unnecessary LCDs into pieces and wash them off with solvents such as acetone and ethanol, which should later be burned.
- (2) If any liquid leaks out of a damaged-glass cell and comes in contact with the hands, wash off thoroughly with soap and water.

10.6 OTHERS

- (1) A strong incident light into LCD panel might cause display characteristic changing inferior because of polarizer film, color filter, and other materials becoming inferior. Please do not expose LCD module direct sunlight and strong UV rays.
- (2) Please pay attention to a panel side of LCD module not to contact with other materials in preserving it alone.
- (3) For the packaging box, please pay attention to the followings:
 - Packaging box and inner case for LCD are designed to protect the LCDs from the damage or scratching during transportation. Please do not open except picking LCDs up from the box.
 - Please do not pile them up more than 3 boxes. (They are not designed so.) And please do not turn over.
 - Please handle packaging box with care not to give them sudden shock and vibrations. And also please do not throw them up.
 - Packing box and inner case for LCDs are made of cardboard. So please pay attention not to get them wet. (Such like keeping them in high humidity or wet place can occur getting them wet)