



Chunghwa Picture Tubes, Ltd.

Technical Specification

To :

Date : 2007/12/06

CPT TFT-LCD
CLAA 154WB08A

ACCEPTED BY :

APPROVED BY	CHECKED BY	PREPARED BY
黃奕凱	劉益群	趙志方

Prepared by : Design General Division

CHUNGHWA PICTUER TUBES, LTD.

No. 1, Huaying Rd., Sanho Tsun, Lungtan Shiang, Taoyuan, Taiwan, 325, R.O.C.
 TEL: +886-3-4805678 FAX: +886-3-4800589

Doc. No:

Issue Date:

2007/12/06

CHUNGHWA PICTUER TUBES, LTD.

TECHNICAL SPECIFICATION

Doc. No : _____

Version : V1Issue Date : 2007/12/06**Title : CLAA154WB08A Technical Specification****1. OVERVIEW**

CLAA154WB08A is 15.4" color (39.116cm) TFT-LCD (Thin Film Transistor Liquid Crystal Display) module composed of LCD panel, LVDS driver ICs, control circuit and backlight. By applying 6 bit digital data, 1280×RGB(3)×800, 262K-color images are displayed on the 15.4" diagonal screen. Interface of data and control signals is Typ. Inverter for backlight is included in this module , General specifications are summarized in the following table :

ITEM	SPECIFICATION
Display Area (mm)	331.2 (H) x 207.0 (V) (15.4-inch diagonal)
Number of Pixels	1280×3(H)×800(V)
Pixel Pitch (mm)	0.25875(H)×0.25875(V)
Color Pixel Arrangement	RGB vertical stripe
Display Mode	Normally white
Number of Colors	262,144(6bits)
Gamut	50%(typ) ; 45%(min)
Optimum Viewing Angle	6 o'clock
Response Time (ms)	16ms
Surface Treatment	Glare, 3H
Viewing Angle (L/R/U/D)	45°、45°/20°、35° (Typ.)
Brightness (cd/m ²)	220 cd/m ² (5point)/6.5 mA (Typ.) 200 cd/m ² (5point)/6.5 mA (Min.)
Uniformity (Min)	5point : 80% 13point : 65%
Consumption of Power (W)	7W (Max) (With Inverter)
Module Size (mm)	344.5(W)×222.5(H)×6.2(D) (Max)
Module Weight (g)	585 (max)

The LCD Products listed on this document are not suitable for use of aerospace equipment, submarine cable, and nuclear reactor control system and life support systems. If customers intend to use these LCD products for applications listed above or those not included in the "Standard" list as follows, please contact our sales in advance.

Standard : Computer, Office equipment, Communication equipment, Test and Measurement equipment, Machine tool, Industrial robot, Audio and Visual equipment, Other consumer products.

2. ABSOLUTE MAXIMUM RATINGS

CHUNGHWA PICTUER TUBES, LTD.

TECHNICAL SPECIFICATION

Doc. No : _____

Version : V1Issue Date : 2007/12/06Title : **CLAA154WB08A****Technical Specification**

The following are maximum value, which if exceeded, may cause faulty operation or damage to the unit.

ITEM	SYMBOL	MIN.	MAX.	UNIT	REMARK	
Power Supply Voltage for LCD	VCC	0	4.0	V		
Lamp voltage	West/ Harrison	VL	700/630	945/900	Vrms	
Lamp current		IL	2	6.5	mArms	*1). 2)
Lamp frequency		FL	50/40	80/80	kHz	
Operation Temperature	Top	0	50	°C	*3). 4). 5). 6)	
Storage Temperature	Tstg	-25	65	°C	*3). 4). 5)	
Delayed Discharge Time	TD	--	1	sec	*7)	

【Note】

- *1) Product life-time relate to lamp current, please operate production follow statement at page 9 “(b)back light” .
- *2) When lamp current over the definition of absolute max, product life-time will decay rapidly or operate unusual.
- *3) The relative temperature and humidity range are as below sketch, 90%RH Max. ($T_a \leq 40^\circ\text{C}$)
- *4) The maximum wet bulb temperature $\leq 39^\circ\text{C}$ ($T_a > 40^\circ\text{C}$) and without dewing.
- *5) If product in environment which over the definition of the relative temperature and humidity out of range too long, it will affect visual of LCD.
- *6) If you operate LCD in normal temperature range, the center surface of panel should be under 60°C .
- *7) Delay discharge time test condition : Starting lamp voltage=1650Vrms. (please follow statement at page 9 “(b) back light”

Before test TD, lamp should operate at least 1min, and lamp current should follow typical lamp current specification. To place panel at room temp. ($25 \pm 2^\circ\text{C}$) below for 24hrs, and then to measure TD with the same starting lamp voltage in dark room.

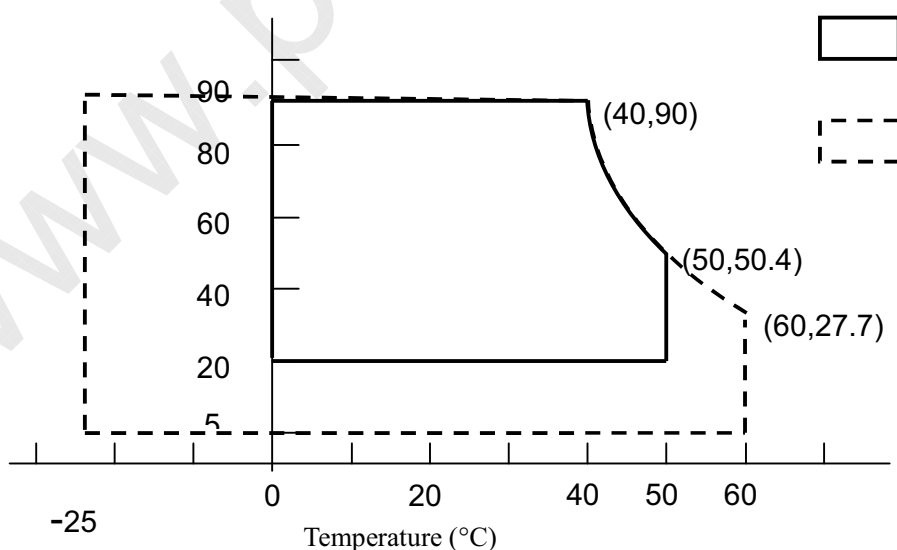
**3. ELECTRICAL CHARACTERISTICS**

CHUNGHWA PICTUER TUBES, LTD.

TECHNICAL SPECIFICATION

Doc. No :

Version : **V1**Issue Date : **2007/12/06****Title : CLAA154WB08A****Technical Specification****(A) TFT LCD**

TEM	SYMBOL	MIN	TYP	MAX	UNIT	REMARK	
LCD POWER VOLTAGE	VCC	3.0	3.3	3.6	V	[Note 1]	
LCD POWER CURRENT	ICC	-	400	600	mA	[Note 2]	
Rush CRRENT	Irush	-	-	2	A	[Note 4]	
LOGIC INPUT VOLTAGE (LVDS: IN+,IN-) [Note 3]	INPUT VOLTAGE	VIN	0	-	VCC	V	
	COMMON VOLTAGE	VCM	1.125	1.25	1.375	V	
	DIFFERENTIAL INPUT VOLTAGE	VID	250	350	450	mV	
	THRESHOLD VOLTAGE (HIGH)	VTH	-	-	100	mV	When VCM = +1.2V
	THRESHOLD VOLTAGE (LOW)	VTL	-100	-	-	mV	
DIFFRENTIAL INPUT VOLTAGE TOLERANCE	Δ VID	-	-	35	mV		
COMMON VOLTAGE TOLERANCE	Δ VCM	-	-	35	mV		

[Note 1] Power Sequence :

$t1 \leq 10\text{ms}$

$0.01 \text{ ms} < t2 \leq 50 \text{ ms}$

$0.01 \text{ ms} < t3 \leq 50 \text{ ms}$

$1 \text{ sec} \leq t5$

$200 \text{ ms} \leq t6$

$200 \text{ ms} \leq t7$

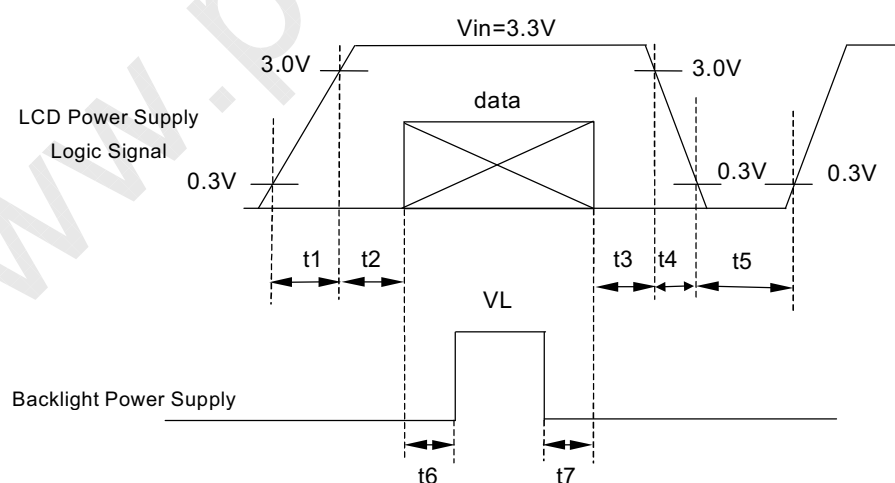

Data: RGB DATA, DCLK, HD, VD, DENA

VCC-dip state

CHUNGHWA PICTUER TUBES, LTD.

TECHNICAL SPECIFICATION

Doc. No : _____

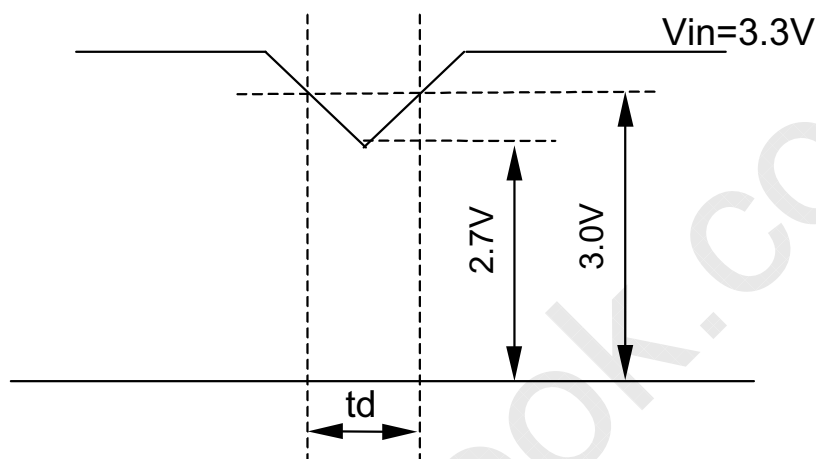
Version : V1Issue Date : 2007/12/06**Title : CLAA154WB08A****Technical Specification**(1)when $3.0 > VCC \geq 2.7V$, $t_d \leq 10$ ms(2)when $VCC < 2.7V$, VCC-dip condition should as the VCC-turn-off condition.

[Note 2]

Typical value is 0~63 gray level.(Horizontal line Pattern)

800 line mode , $VCC = +3.3V$

Circuit condition (Typ.)

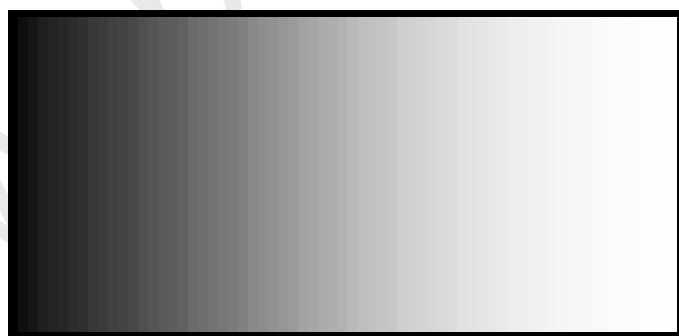
 $VCC = 3.3 V$, $f_V = 60$ Hz $f_H = 48.9$ kHz , $f_{CLK} = 68.9$ MHz

64-Gray:

Circuit condition (MAX.)

 $VCC = 3.3 V$, $f_V = 60$ Hz $f_H = 48.9$ kHz , $f_{CLK} = 68.9$ MHz

CHUNGHWA PICTUER TUBES, LTD.

TECHNICAL SPECIFICATION

Doc. No : _____
 Version : V1
 Issue Date : 2007/12/06

Title : CLAA154WB08A Technical Specification

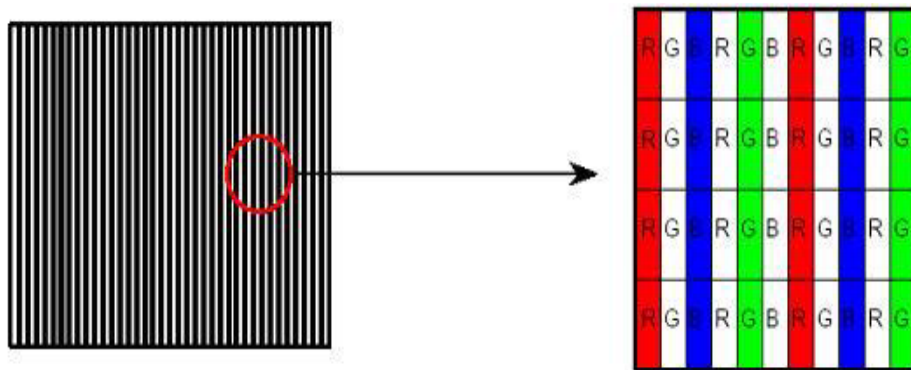

[Note 3] LVDS Signal Definite :

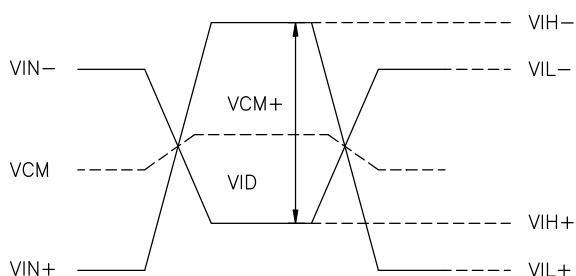
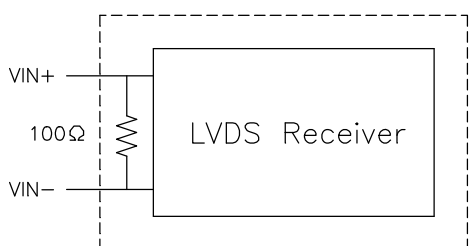

$$VID = VIN+ - VIN-$$

$$\Delta VCM = |VCM+ - VCM-|$$

$$\Delta VID = |VID+ - VID-|$$

$$VID+ = |VIH+ - VIH-|$$

$$VID- = |VIL+ - VIL-|$$

$$VCM = (VIN+ + VIN-)/2$$

$$VCM+ = (VIH+ + VIH-)/2$$

$$VCM- = (VIL+ + VIL-)/2$$

VIN+ : Positive differential DATA & CLK Input
 VIN- : Negative differential DATA & CLK Input

Refer to Inverter rated voltage

[Note 4] Irush measure condition

CHUNGHWA PICTUER TUBES, LTD.

TECHNICAL SPECIFICATION

Doc. No : _____

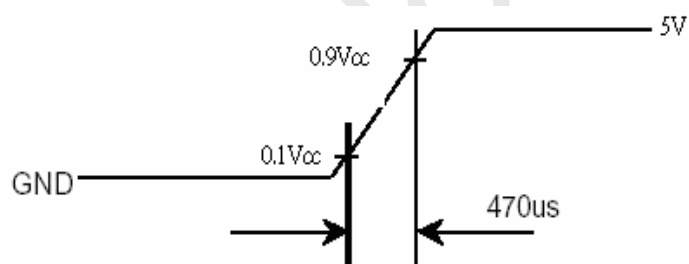
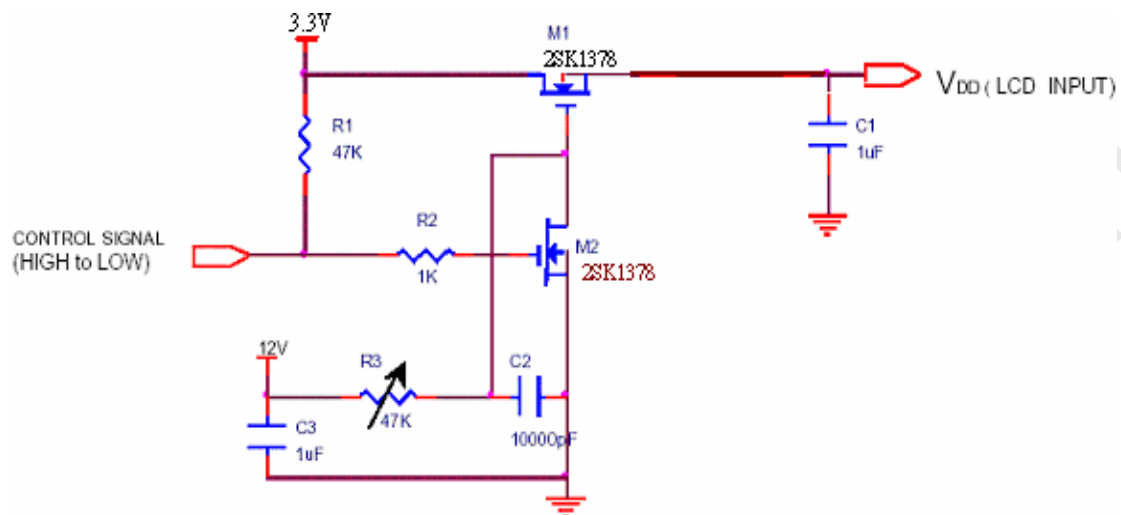
Version : V1Issue Date : 2007/12/06**Title : CLAA154WB08A****Technical Specification****(B) BACK LIGHT**

CHUNGHWA PICTUER TUBES, LTD.

TECHNICAL SPECIFICATION

Doc. No : _____

Version : V1Issue Date : 2007/12/06**Title : CLAA154WB08A Technical Specification**

(a.) ELECTRICAL CHARACTERISTICS

Lamp:

Ta=25°C

ITEM	SYMBOL	MIN	TYP	MAX	UNIT	REMARK
Lamp Voltage(IL=6.0mA)	VL	657	730	803	Vrms	IL=6.0mA
Lamp Current	IL	5.5	6.0	6.5	mArms	*1)
Inverter Frequency	FI	50	--	60	kHz	*2)
Lamp Initial Voltage	VS	1460	--		Vrms	Ta=25°C
		1650	--		Vrms	Ta=0°C

(b) LAMP LIFE – TIME

Lamp:

ITEM	IL at 2.0 mA	IL at 6.0 mA	IL at 6.5 mA	UNIT	REMARK
LAMP LIFE-TIME (LT)	Min. 15,000	Min. 15,000	Min.10,000	hr	Continuous Operation*3)
Turn-on and turn-off Operation	--	Min.100,000	--	times	Continuous Operation *4)

*1)Measure method : Galvanometer connect to low voltage

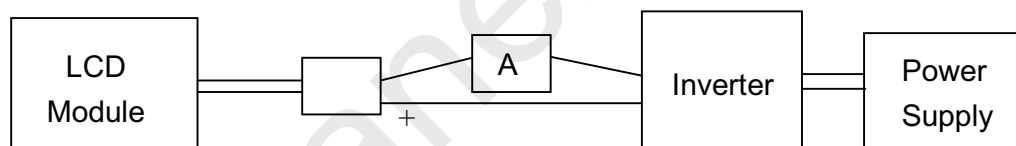

*2) Frequency in this range can make the characteristics of electric and optics maintain in +/- 10% except hue.

Lamp frequency of inverter may produce interference with horizontal synchronous frequency, and this may cause horizontal beat on the display. Therefore, please adjust lamp frequency, and keep inverter as far from module as possible or use electronic shielding between inverter and module to avoid the interference.

Under optimum operate frequency range (50~80 KHz), will not effect panel life-time and reliability .

*3) Definition of the lamp life time :

- a. Luminance (L) under 50% of specification starting lamp voltage
- b. Starting Lamp Voltage: over130% of the initial value. Ta=25°C

*4) For keeping good lighting situation, when design the inverter, it must be considered that the voltage large than starting lamp voltage.

4. Connector Interface PIN & Function

CHUNGHWA PICTUER TUBES, LTD.

TECHNICAL SPECIFICATION

Doc. No : _____

Version : V1Issue Date : 2007/12/06**Title : CLAA154WB08A Technical Specification**

Backlight-side connector: BHSR-02VS-1 (JST)

Inverter-side connector: SM02B-BHSS-1 (JST)

Pin No.	Symbol	Function
1	CTH	VBLH (High)
2	CTL	VBLL (Low)

[Note] : VBLH-VBLL=VL

[Note]

BIST (Build in self-test pattern)

BIST pin = low(GND) : Normal

BIST pin = high(VCC) : Self-test mode

1) Self-test Display Pattern change when pin 5 is high and no LVDS input signals detected, as followed patterns runs continuously. (Black, White, Red, Green and Blue).

2) Pattern sequence

Pattern1 → Pattern2 → Pattern3 → Pattern4 → Pattern5 → Pattern1 →

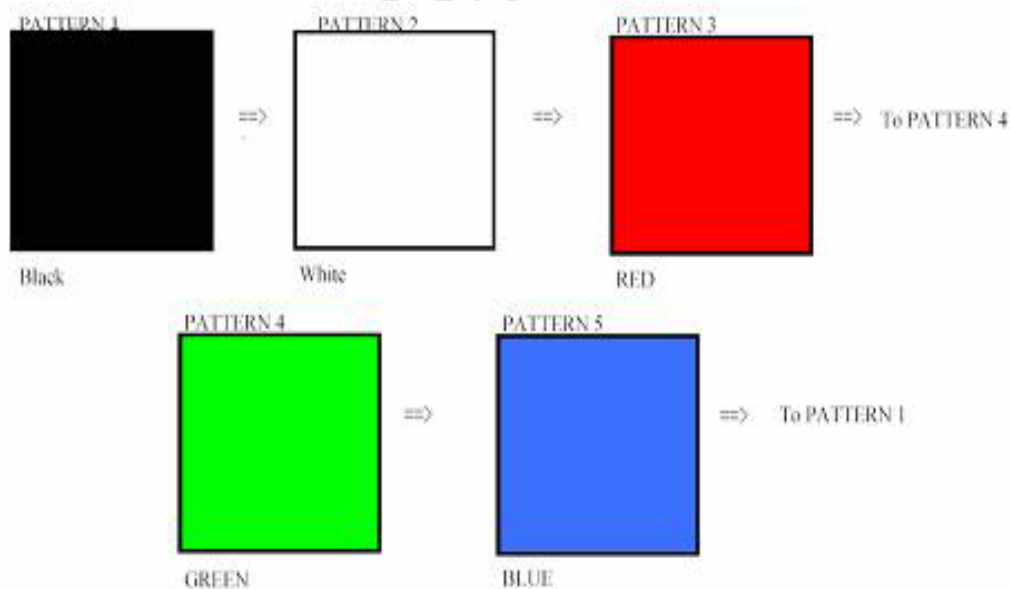
**5. INTERFACE TIMING CHART**

(a). LVDS input time sequence

CHUNGHWA PICTUER TUBES, LTD.

TECHNICAL SPECIFICATION

Doc. No :

Version : V1

Issue Date : 2007/12/06

Title : CLAA154WB08A

Technical Specification

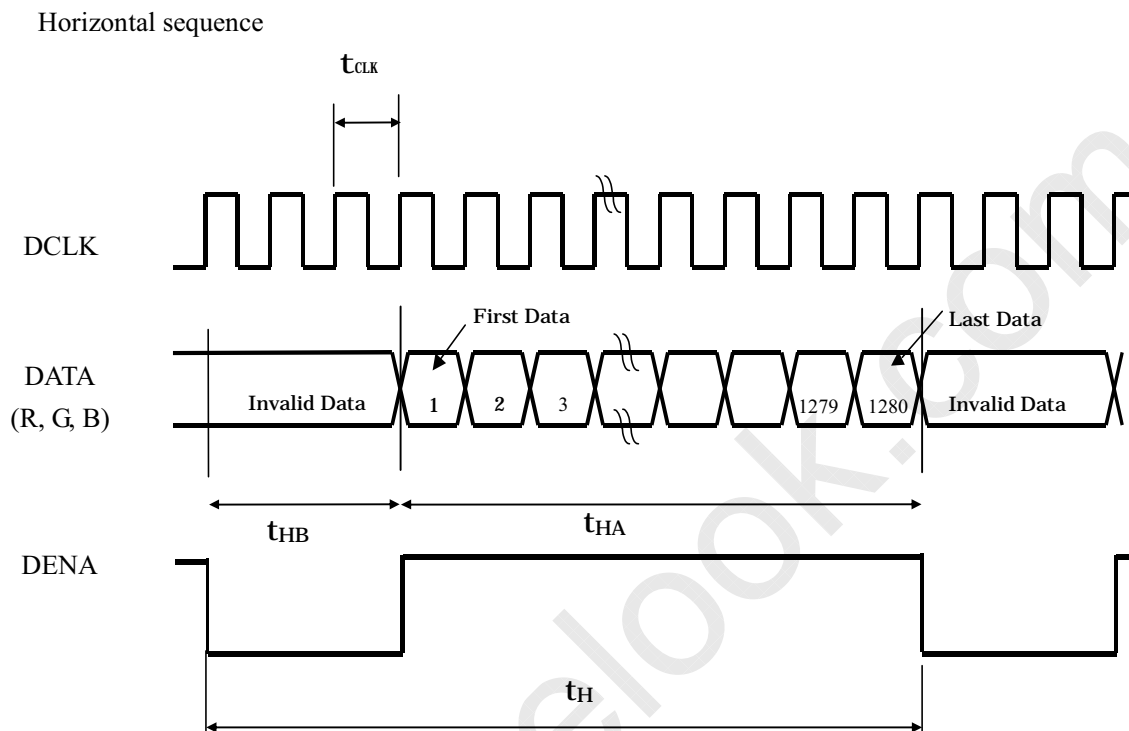

(b) LCD input time sequence

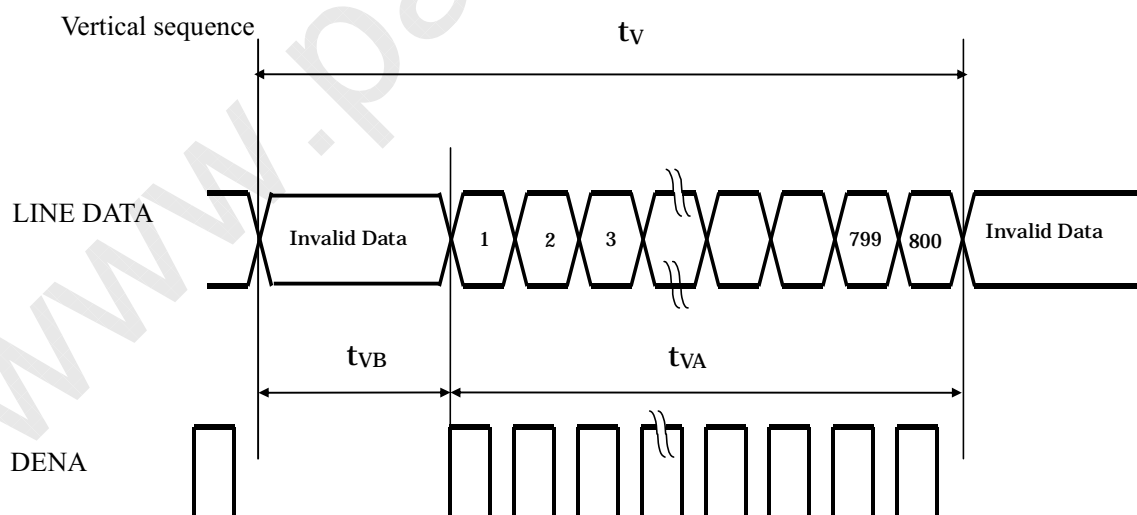

(C) Timing Chart

CHUNGHWA PICTUER TUBES, LTD.

TECHNICAL SPECIFICATION

Doc. No : _____

Version : V1Issue Date : 2007/12/06**Title : CLAA154WB08A****Technical Specification**

ITEM			SYMBOL	MIN	TYP	MAX	UNIT	
LCD Timing	DCLK		Frequency	f_{CLK}	65.3	71	74.7	MHz
			Period	t_{CLK}	15.3	14.08	13.3	ns
	DENA	Horizontal	Horizontal total time	t_H	1344	1424	1500	t_{CLK}
			Horizontal Active time	t_{HA}	1280	1280	1280	t_{CLK}
			Horizontal Blank time	t_{HB}	64	144	220	t_{CLK}
		Vertical	Vertical total time	t_V	810	816	830	t_H
			Vertical Active time	t_{VA}	800	800	800	t_H
			Vertical Blank time	t_{VB}	10	16	30	t_H

[Note]

- *1) Data is latched during DCLK falling period.
- *2) HD、VD is negative.
- *3) DENA (DATA ENABLE) usually is positive.
- *4) During the whole blank period, DCLK should keep input.
During the vertical blank period, HD should keep input.

(d) DATA mapping

Color	Input Data	R DATA	G DATA	B DATA
-------	------------	--------	--------	--------

CHUNGHWA PICTUER TUBES, LTD.

TECHNICAL SPECIFICATION

Doc. No : _____
 Version : V1
 Issue Date : 2007/12/06

Title : CLAA154WB08A Technical Specification

		R5	R4	R3	R2	R1	R0	G5	G4	G3	G2	G1	G0	B5	B4	B3	B2	B1	B0
		MS B					LS B	MS B					LS B	MS B					LS B
Basic Color	Black	0	0	0	0	0	0	0	0	0	0	0	0	0	0	0	0	0	0
	Red(63)	1	1	1	1	1	1	0	0	0	0	0	0	0	0	0	0	0	0
	Green(63)	0	0	0	0	0	0	1	1	1	1	1	1	0	0	0	0	0	0
	Blue(63)	0	0	0	0	0	0	0	0	0	0	0	0	1	1	1	1	1	1
	Cyan	0	0	0	0	0	0	1	1	1	1	1	1	1	1	1	1	1	1
	Magenta	1	1	1	1	1	1	0	0	0	0	0	0	1	1	1	1	1	1
	Yellow	1	1	1	1	1	1	1	1	1	1	1	1	0	0	0	0	0	0
	White	1	1	1	1	1	1	1	1	1	1	1	1	1	1	1	1	1	1
RED	RED(0)	0	0	0	0	0	0	0	0	0	0	0	0	0	0	0	0	0	0
	RED(1)	0	0	0	0	0	1	0	0	0	0	0	0	0	0	0	0	0	0
	RED(2)	0	0	0	0	1	0	0	0	0	0	0	0	0	0	0	0	0	0
	RED(62)	1	1	1	1	1	0	0	0	0	0	0	0	0	0	0	0	0	0
	RED(63)	1	1	1	1	1	1	0	0	0	0	0	0	0	0	0	0	0	0
Green	Green(0)	0	0	0	0	0	0	0	0	0	0	0	0	0	0	0	0	0	0
	Green(1)	0	0	0	0	0	0	0	0	0	0	0	1	0	0	0	0	0	0
	Green(2)	0	0	0	0	0	0	0	0	0	0	1	0	0	0	0	0	0	0
	Green(62)	0	0	0	0	0	0	1	1	1	1	1	0	0	0	0	0	0	0
	Green(63)	0	0	0	0	0	0	1	1	1	1	1	1	0	0	0	0	0	0
Blue	Blue(0)	0	0	0	0	0	0	0	0	0	0	0	0	0	0	0	0	0	0
	Blue(1)	0	0	0	0	0	0	0	0	0	0	0	0	0	0	0	0	0	1
	Blue(2)	0	0	0	0	0	0	0	0	0	0	0	0	0	0	0	0	1	0
	Blue(62)	0	0	0	0	0	0	0	0	0	0	0	0	1	1	1	1	1	0
	Blue(63)	0	0	0	0	0	0	0	0	0	0	0	0	1	1	1	1	1	1

[Note]

1) Gray level:

Color(n) : n is level order; higher n means brighter level.

2) DATA:

1: high , 0: low

6. BLOCK DIAGRAM

CHUNGHWA PICTUER TUBES, LTD.

TECHNICAL SPECIFICATION

Doc. No :

Version : V1

Issue Date : 2007/12/06

Title : CLAA154WB08A

Technical Specification

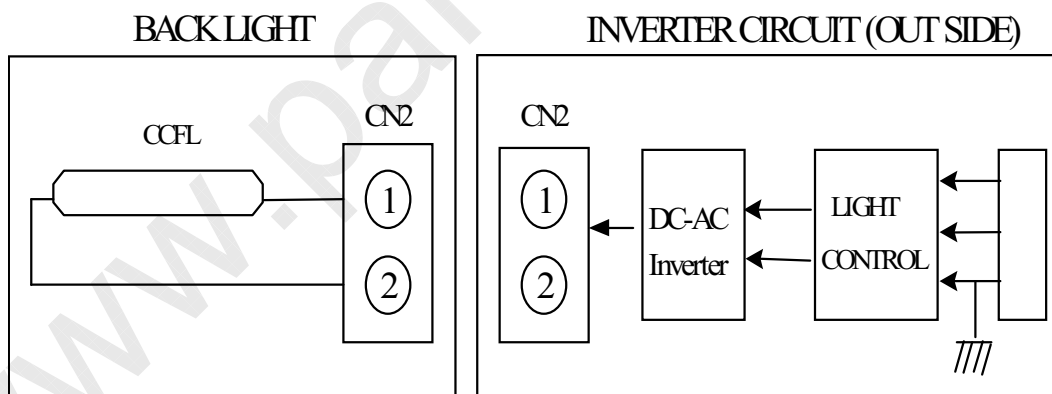
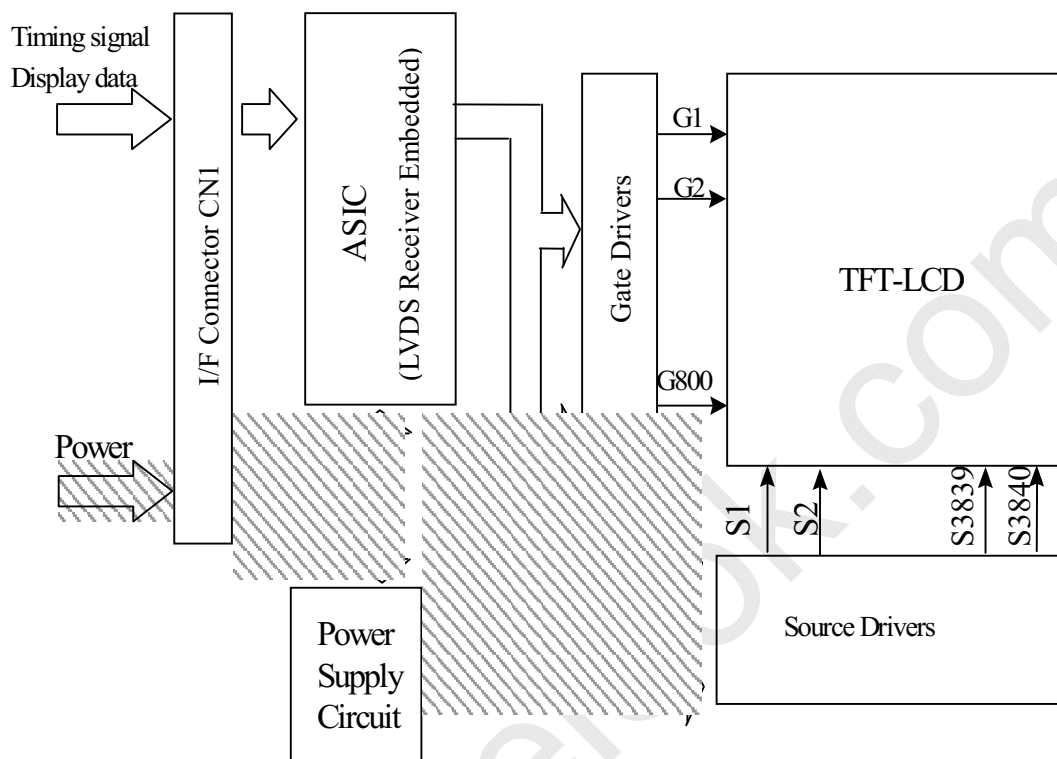

7. MECHANICAL SPECIFICATION

(1) Front side

CHUNGHWA PICTUER TUBES, LTD.

TECHNICAL SPECIFICATION

Doc. No :

Version : V1

Issue Date : 2007/12/06

Title : CLAA154WB08A

Technical Specification

The tolerance, not show in the figure, is $\pm 0.5\text{mm}$.

[Unit : mm]

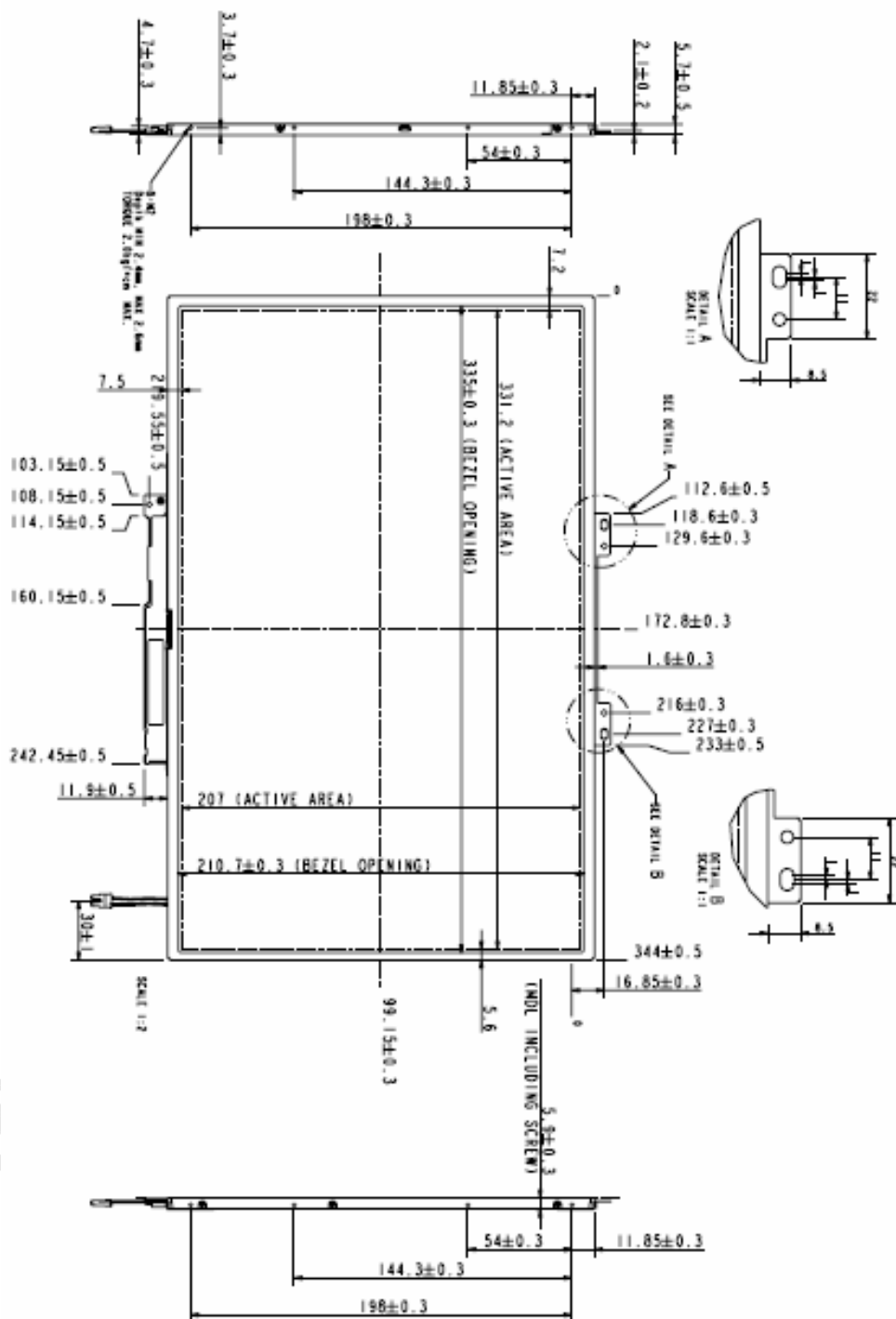

2) Rear side

CHUNGHWA PICTUER TUBES, LTD.

TECHNICAL SPECIFICATION

Doc. No :

Version : V1Issue Date : 2007/12/06**Title : CLAA154WB08A****Technical Specification**The tolerance, not show in the figure, is $\pm 0.5\text{mm}$.

[Unit : mm]

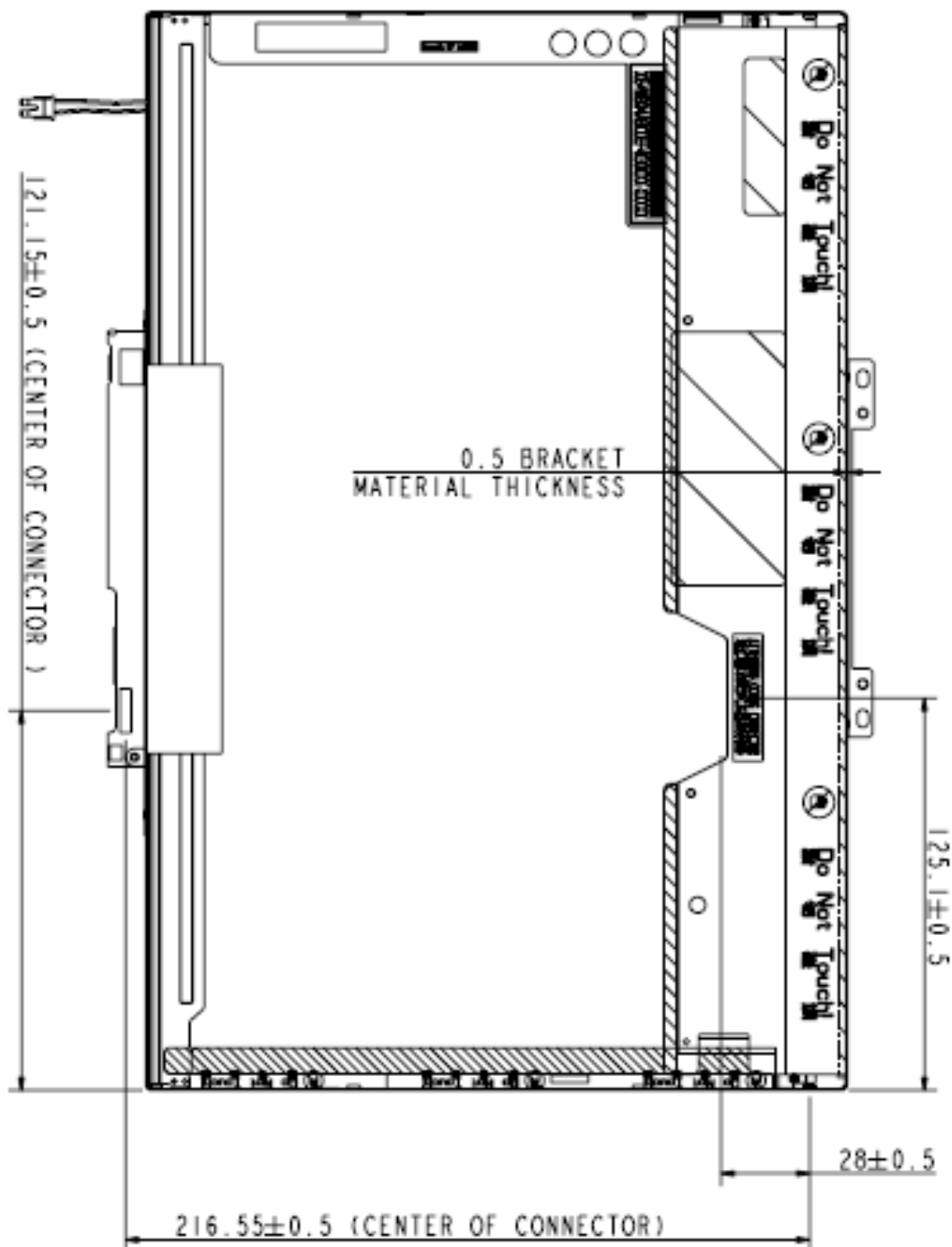
**8. OPTICAL CHARACTERISTICS** $T_a = 25^\circ\text{C}$, $V_{DD} = 3.3\text{V}$

CHUNGHWA PICTUER TUBES, LTD.

TECHNICAL SPECIFICATION

Doc. No : _____

Version : V1Issue Date : 2007/12/06Title : **CLAA154WB08A****Technical Specification**

ITEM	SYMBOL	CONDITION	MIN.	TYP.	MAX.	UNIT	REMARK	
Contrast Ratio	CR	$\theta = \psi = 0^\circ$	300	350		--	*1)	
Luminance (5P)	L	$\theta = \psi = 0^\circ$	200	220		cd/m ²	*2)	
Uniformity(5P)	ΔL	$\theta = \psi = 0^\circ$	80			%	*2)	
Uniformity(13P)	ΔL	$\theta = \psi = 0^\circ$	65			%		
Response Time	Tr	$\theta = \psi = 0^\circ$		6	9	ms	*4)	
	Tf	$\theta = \psi = 0^\circ$		10	16	ms	*4)	
Image sticking	Tis	16 hours		-	20	min	*5)	
Cross talk	CT	$\theta = \phi = 0^\circ$ ^{*3}			1	%	*6)	
View angle	Horizontal	ψ	$CR \geq 10$	40/-40	45/-45		°	*3)
	Vertical	θ		15/-30	20/-35		°	*3)
Color Temperature Coordinate	W	X	$\theta = \psi = 0^\circ$	0.293	0.313	0.333	*2)	
		Y		0.309	0.329	0.349		
	R	X		0.585	0.605	0.625		
		Y		0.327	0.347	0.367		
	G	X		0.295	0.315	0.335		
		Y		0.561	0.581	0.601		
	B	X		0.133	0.153	0.173		
		Y		0.106	0.126	0.146		
Gamut		$\theta = \psi = 0^\circ$	45%	50%		%		
Gamma	γ	GL	2.0	2.2	2.4		*7)	

Color coordinate and color gamut are measured by CS-1000, and all the other items are measured by BM-5A (TOPCON). All these items are measured under the dark room condition (no ambient light).

Measurement Condition: IL = 6.5 mA (SMB_DATA=FFH)

Inverter : SUMIDA / IV12139/T

Definition of these measurement items is as follows:

***1) Definition of Contrast Ratio**

CR=ON (White) Luminance/OFF (Black) Luminance

***2) Definition of Luminance and Luminance uniformity**

Central luminance: The white luminance is measured at the center position "5" on the screen, see Fig.1 below.

5P Luminance (AVG): The white luminance is measured at measuring points 5、10、11、12、13, see Fig. 1 below.

5P Uniformity: $\Delta L = (L_{min} / L_{max}) \times 100\%$

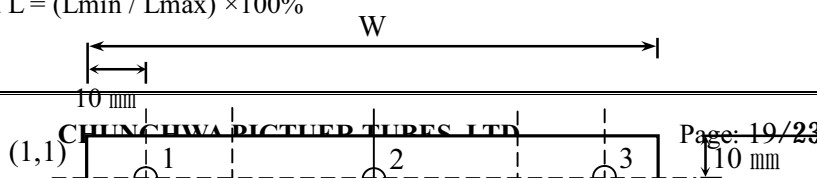

CHUNGHWA PICTUER TUBES, LTD.

TECHNICAL SPECIFICATION

Doc. No : _____

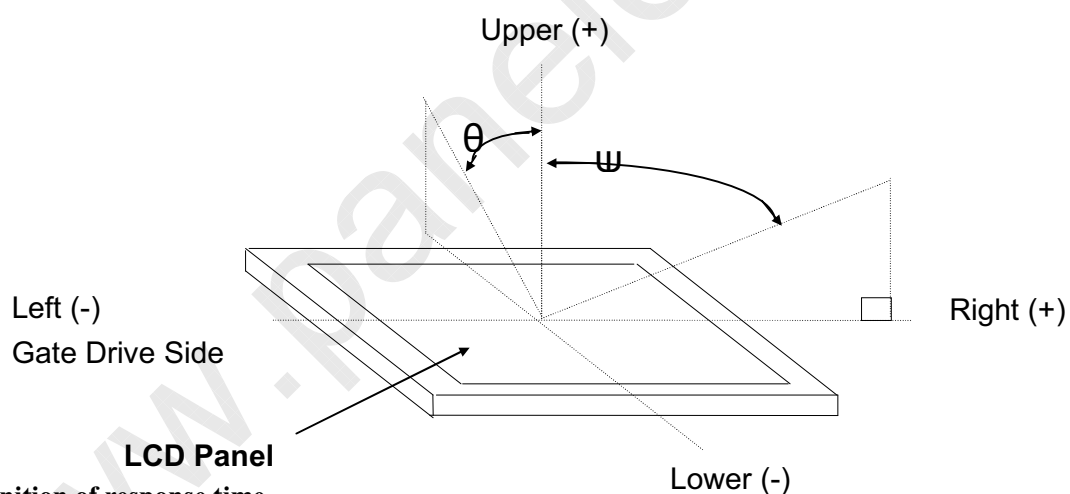
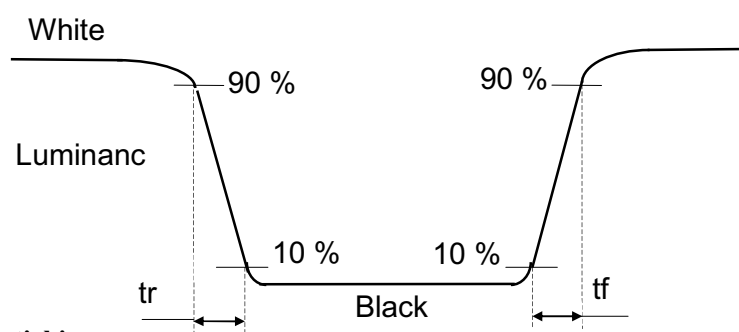
Version : V1Issue Date : 2007/12/06**Title : CLAA154WB08A****Technical Specification*****3) Definition of view angle(θ , ψ)*****4) Definition of response time*****5) Definition of image sticking**

Continuously display the test pattern shown in the figure below for 16 hrs. At 25°C.

CHUNGHWA PICTUER TUBES, LTD.

TECHNICAL SPECIFICATION

Doc. No : _____
 Version : V1
 Issue Date : 2007/12/06

Title : CLAA154WB08A Technical Specification

To change the picture to gray pattern (gray 32 pattern), and the previous image shall not persist during 20 min .

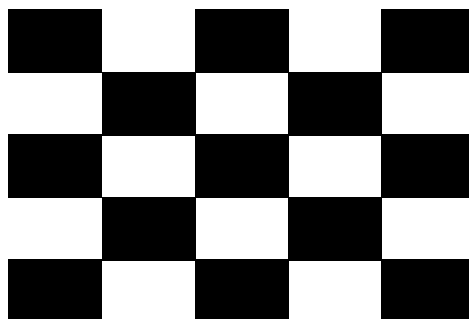

White : 63 Gray
 Black : 0 Gray

*6) Crosstalk Modulation Ratio:

$$CT = | Y_B - Y_A | / Y_A \times 100\%$$

Y_A 、 Y_B measure position and definition

Y_A means luminance at gray level 32(exclude gray level 0 pattern)

Y_B means luminance at gray level 32(include gray level 0 pattern)

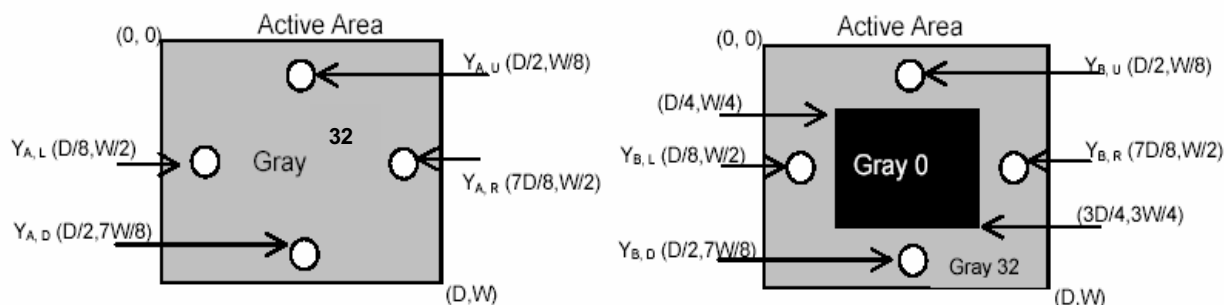

*7) Definition Gamma (VESA)

Based on Customer Sample, take the average value as a standard center value and the variation range of Gamma value caused by loop voltage error should be between +/- 0.2. the bellow figure shows how to obtain the gamma curve and γ (from gray level: 0 、 16 、 32-----224 、 240 、 255).

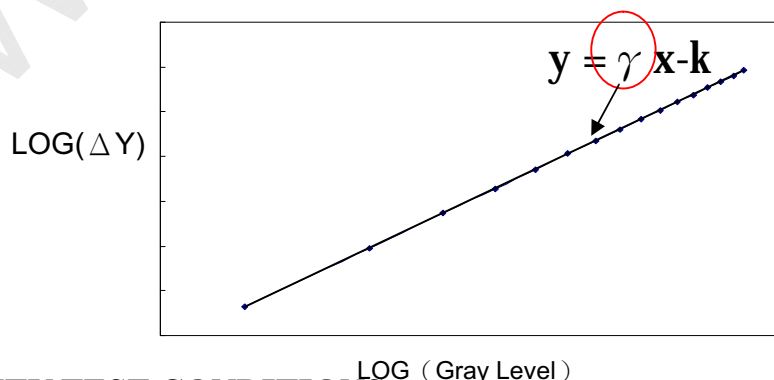

9. RELIABILITY TEST CONDITIONS

(1) Temperature 、 Humidity and Pressure

CHUNGHWA PICTUER TUBES, LTD.

TECHNICAL SPECIFICATION

Doc. No :

Version : V1Issue Date : 2007/12/06**Title : CLAA154WB08A****Technical Specification**

TEST ITEMS	CONDITIONS
High Temperature Operation	50° C ; 250Hrs
High Temperature Storage	65° C ; 250Hrs
High Temperature High Humidity Operation	40° C ; 95% RH ; 250Hrs
High Temperature High Humidity Storage	60° C ; 95% RH ; 48 Hrs
Low Temperature Operation	0° C ; 250 Hrs
Low Temperature Storage	-25° C ; 250 Hrs
Thermal Shock	-40° C (30 Mins)~65° C (30 Mins) , Ramp<20° C , 100 CYCLE
Temperature and Pressure Storage	25° C 、 260hPa 、 24hrs

(2) Shock & Vibration

TEST ITEMS	CONDITIONS
Shock (Non-Operation)	Shock level : 2450m/s ² (250G), Waveform : half sinusoidal wave, 2ms, 6 axis (± X, ± Y, ± Z) per cycle
Vibration (Non-Operation)	Vibration level : 14.7m/s ² (1.5G), sinusoidal wave (each x,y,z axis : 1hr, total 3hrs) Frequency range : 5 ~ 500 Hz Sweep speed : 0.5 Octave/min.

(3) ESD

Power on or off	Power on			Power off	
	Surface discharge(Panel display area 、 Frame 、 PWB 、 Panel back side)		Electric capacity of Connector	Surface discharge (Frame)	Surface discharge (Edge of panel)
Mode	Contact	Air	Contact	Contact	Air
Capacity	150 pF	150 pF	200 pF	150 pF	150 pF
Resistance	330 Ω	330 Ω	0 Ω	330 Ω	330 Ω
Voltage	±8kV/±15kV	±8kV/±15kV	±250 V	±6kV/±8kV	±8kV/±15kV
Interval	1 sec	1 sec	1 sec	1 sec	1 sec
Times(single point)	25	25	1	25	25

(4) MTBF without B/L: 200,000 Hrs (min) lifetimes.

CHUNGHWA PICTUER TUBES, LTD.

TECHNICAL SPECIFICATION

Doc. No :

Version : V1

Issue Date : 2007/12/06

Title : CLAA154WB08A Technical Specification

(5) Judgment standard

The judgment of the above test should be made as follow:

Pass : Normal display image with no obvious non-uniformity and no line defect.

Partial transformation of the module parts should be ignored.

Fail : No display image, obvious non-uniformity, or line defects.