



Chunghwa Picture Tubes, Ltd.

Technical Specification

To : HAOSHENG

Date : 2009/08/06

CPT TFT-LCD

CLAA154WP04A

ACCEPTED BY :

APPROVED BY	CHECKED BY	PREPARED BY
Ronald Huang	Roger Liu	Carol Shen

Doc.No:	CLAA154WP04A-HAOSHENG-T1-2009/08/06	Issue Date:	2009/08/06
---------	-------------------------------------	-------------	------------

1. OVERVIEW

CLAA154WP04A is 15.4" color (39.116cm) TFT-LCD (Thin Film Transistor Liquid Crystal Display) module composed of LCD panel, LVDS driver ICs, control circuit and backlight. By applying 6 bit digital data, 1440×RGB(3)×900, 262K-color images are displayed on the 15.4" diagonal screen. Interface of data and control signals is Typ. Inverter for backlight is included in this module(Invert vender : SUMIDA · FOXCONN).General specifications are summarized in the following table :

ITEM	SPECIFICATION
Display Area (mm)	331.56 (H) x 207.225 (V) (15.4-inch diagonal)
Number of Pixels	1440×3(H)×900(V)
Pixel Pitch (mm)	0.23025(H)×0.23025(V)
Color Pixel Arrangement	RGB vertical stripe
Display Mode	Normally white
Number of Colors	262,144(6bits)(RSDS)
Gamut	45%(typ) ; 42%(min)
Optimum Viewing Angle	6 o'clock
Response Time (ms)	8ms
Viewing Angle (L/R/U/D)	60°、60° /45°、55° (Typ.)
Brightness (cd/m ²)	250 cd/m ² (5point)/6 mA (Typ.) 220 cd/m ² (5point)/6 mA (Min.)
Uniformity (Min)	5point : 80% 13point : 65%
Consumption of Power (W)	7W (Max) (with Inverter)
Module Size (mm)	344.5(W)×222.5(H)×6.0(D) (Max)
Module Weight (g)	545 (max)

The LCD Products listed on this document are not suitable for use of aerospace equipment, submarine cable, and nuclear reactor control system and life support systems. If customers intend to use these LCD products for applications listed above or those not included in the "Standard" list as follows, please contact our sales in advance.

Standard : Computer, Office equipment, Communication equipment, Test and Measurement equipment, Machine tool, Industrial robot, Audio and Visual equipment, Other consumer products.

2. ABSOLUTE MAXIMUM RATINGS

The following are maximum value, which if exceeded, may cause faulty operation or damage to the unit.

ITEM	SYMBOL	MIN.	MAX.	UNIT	REMARK
Power Supply Voltage for LCD	VCC	0	4.0	V	
Lamp voltage	VL	630	900	Vrms	
Lamp current	Harrison	IL	2	mArms	*1). 2)
Lamp frequency		FL	40	80	kHz
Operation Temperature	Top	0	50	°C	*3). 4). 5). 6)
Storage Temperature	Tstg	-25	65	°C	*3). 4). 5)
Delayed Discharge Time	TD	--	1	sec	*7)

【Note】

- *1) Product life-time relate to lamp current, please operate production follow statement at page 9 “(b)back light” .
- *2) When lamp current over the definition of absolute max. ,product life-time will decay rapidly or operate unusual.
- *3) The relative temperature and humidity range are as below sketch, 90%RH Max. ($T_a \leq 40^\circ\text{C}$)
- *4) The maximum wet bulb temperature $\leq 39^\circ\text{C}$ ($T_a > 40^\circ\text{C}$) and without dewing.
- *5) If product in environment which over the definition of the relative temperature and humidity out of range too long, it will affect visual of LCD.
- *6) If you operate LCD in normal temperature range, the center surface of panel should be under 60°C .
- *7) Delay discharge time test condition : starting lamp voltage=1650Vrms.(please follow statement at page 9 “(b)back light”

Before test TD,lamp should operate at least 1min,and lamp current should follow trpical lamp current specification. To place panel at room temp.($25 \pm 2^\circ\text{C}$)below for 24hrs.,and then to measue TD with the same starting lamp voltage in dark room.

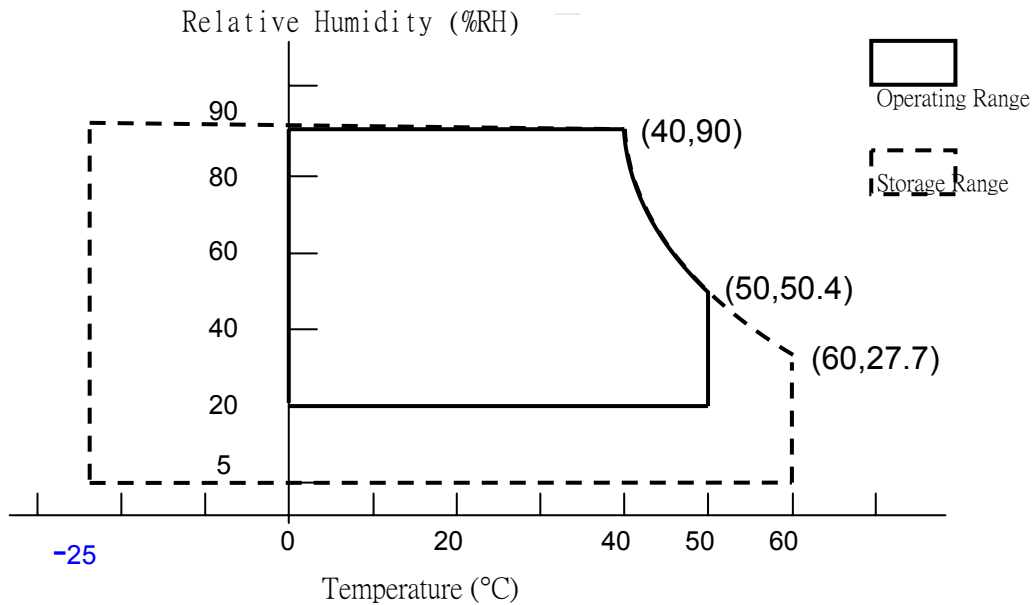

3. ELECTRICAL CHARACTERISTICS

(A) TFT LCD

TEM	SYMBOL	MIN	TYP	MAX	UNIT	REMARK	
LCD POWER VOLTAGE	VCC	3.0	3.3	3.6	V	[Note 1]	
LCD POWER CURRENT	ICC	-	500	600	mA	[Note 2]	
Rush CRRENT	Irush	-	-	3	A	[Note 4]	
LOGIC INPUT VOLTAGE (LVDS: IN+,IN-) [Note 3]	INPUT VOLTAGE	VIN	0	-	VCC	V	
	COMMON VOLTAGE	VCM	1.125	1.25	1.375	V	
	DIFFERENTIAL INPUT VOLTAGE	VID	250	350	450	mV	
	THRESHOLD VOLTAGE (HIGH)	VTH	-	-	100	mV	When VCM = +1.2V
	THRESHOLD VOLTAGE (LOW)	VTL	-100	-	-	mV	
DIFFERENTIAL INPUT VOLTAGE TOLERANCE	Δ VID	-	-	35	mV		
COMMON VOLTAGE TOLERANCE	Δ VCM	-	-	35	mV		

[Note 1] Power Sequence :

- 0.5 ms < t1 ≤ 10ms
- 0.01 ms < t2 ≤ 50 ms
- 0.01 ms < t3 ≤ 50 ms
- 0.01 ms < t4 ≤ 10 ms
- 1 sec ≤ t5
- 200 ms ≤ t6
- 200 ms ≤ t7

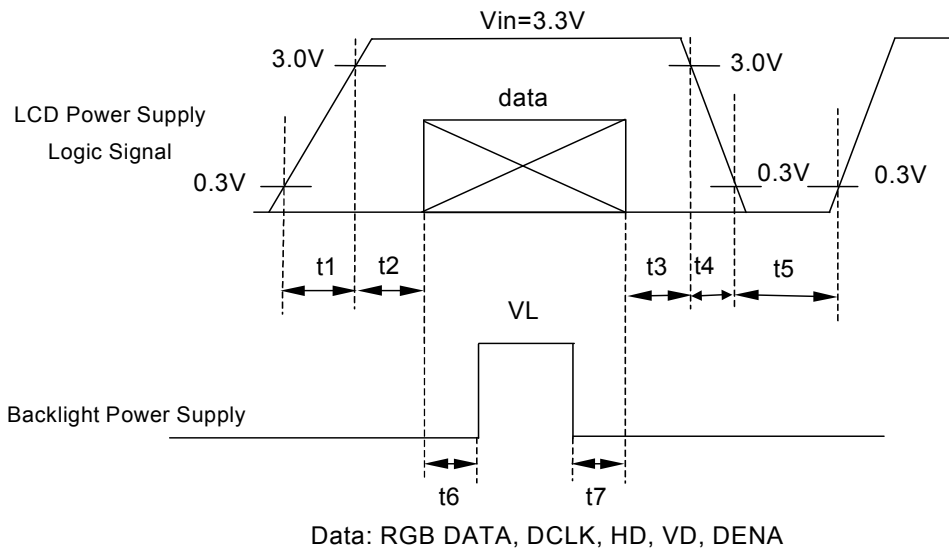

VCC-dip state

- (1) when $3.0 > VCC \geq 2.7V$, $t_d \leq 10$ ms
- (2) when $VCC < 2.7V$, VCC-dip condition should as the VCC-turn-off condition.

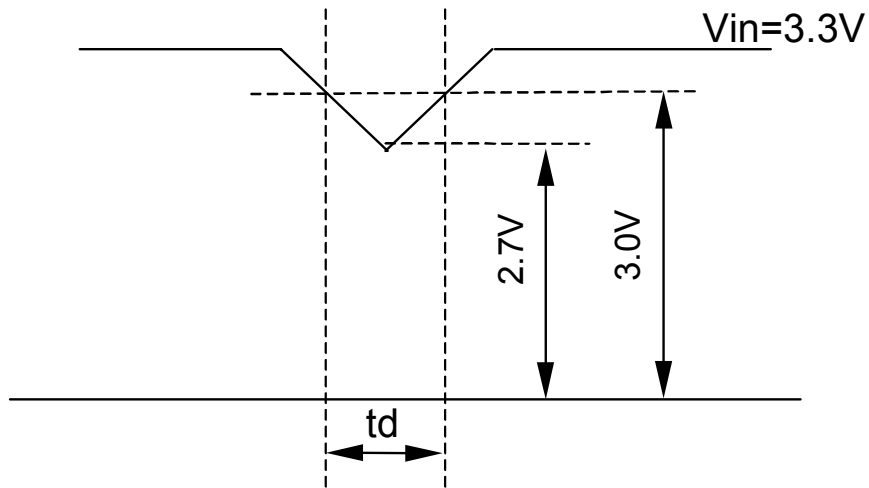

[Note 2]

Typical value is 0~63 gray level.(horizontal line Pattern)

900 line mode , VCC= +3.3V

Circuit condition(Typ.)

VCC=3.3 V , fV=60 Hz fH=55.56 kHz , fCLK=44.375 MHz

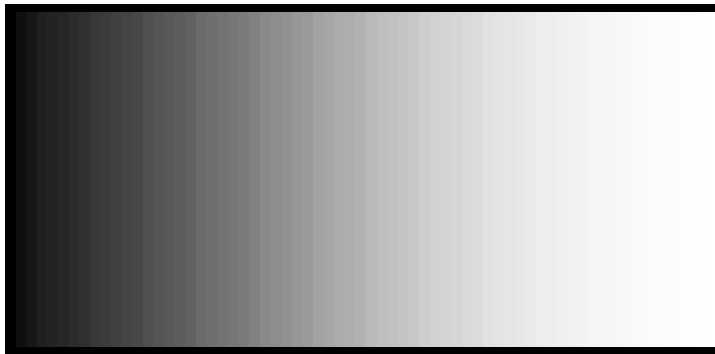

64-Gray :
0 ~ 63 Gray

Circuit condition(MAX.)

VCC=3.3 V , fV=60 Hz fH=55.56 kHz , fCLK=44.375 MHz

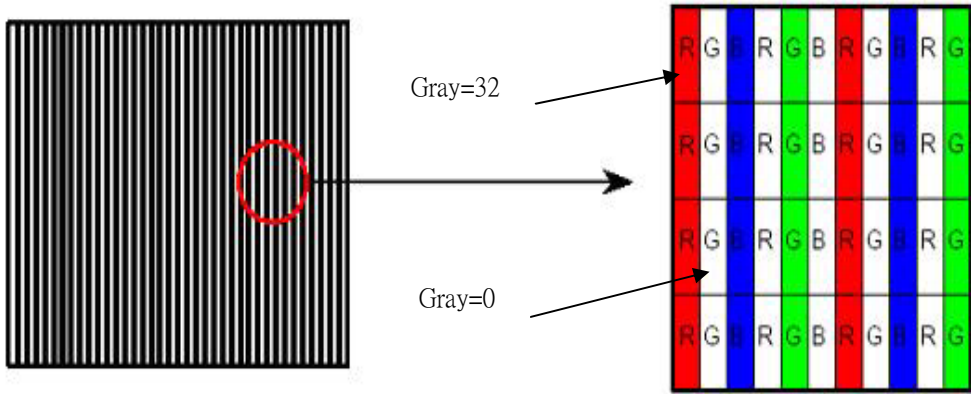

[Note 3] LVDS Signal Definite :

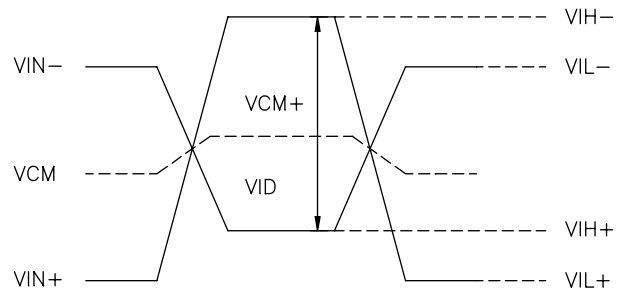
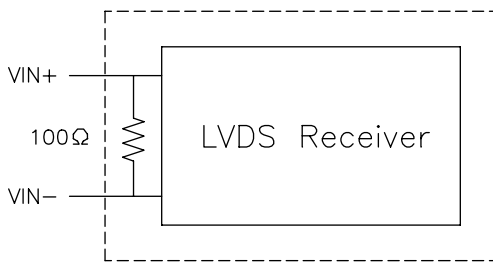

$$\begin{aligned}
 VID &= VIN+ - VIN-, \\
 \Delta VCM &= | VCM+ - VCM- |, \\
 \Delta VID &= | VID+ - VID- |, \\
 VID+ &= | VIH+ - VIH- |, \\
 VID- &= | VIL+ - VIL- |, \\
 VCM &= (VIN+ + VIN-)/2, \\
 VCM+ &= (VIH+ + VIH-)/2, \\
 VCM- &= (VIL+ + VIL-)/2,
 \end{aligned}$$

VIN+ : Positive differential DATA & CLK Input
 VIN- : Negative differential DATA & CLK Input

4) Refer to Inverter rated voltage
 [Note 4] Irush measure condition

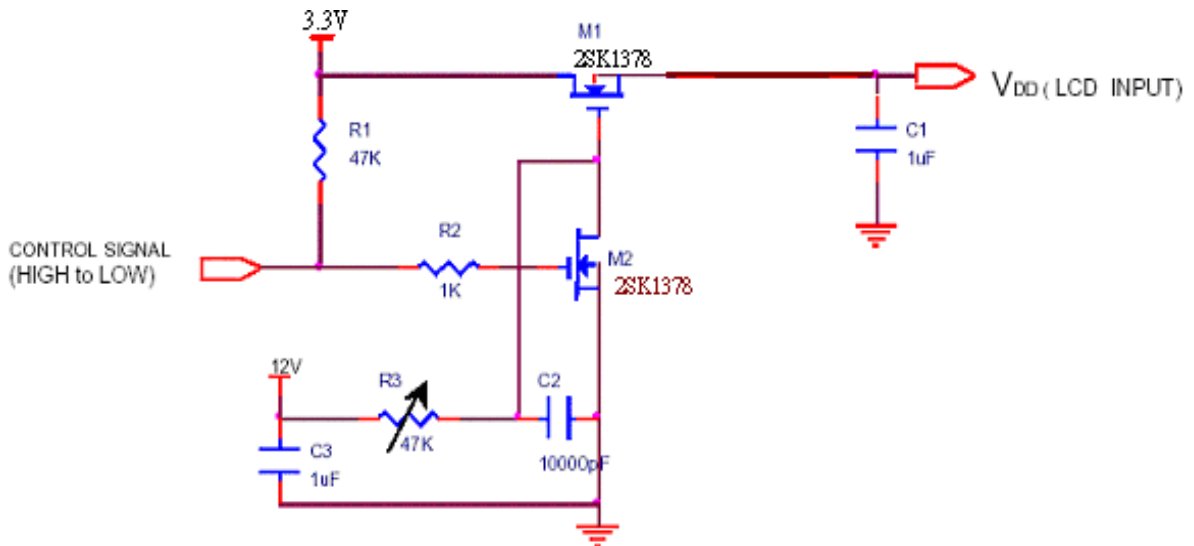

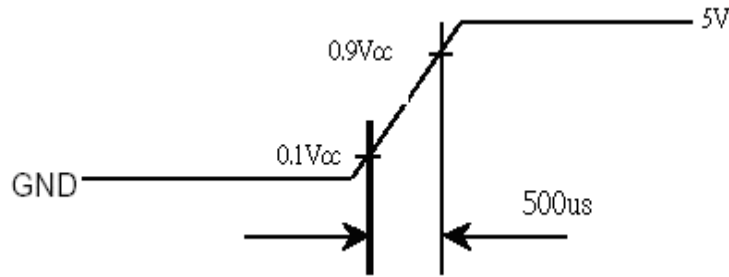

(B) BACK LIGHT

(a.) ELECTRICAL CHARACTERISTICS

Harrison Lamp:

Ta=25°C

ITEM	SYMBOL	MIN	TYP	MAX	UNIT	REMARK
Lamp Voltage(IL=6.0mA)	VL	630	700	770	Vrms	IL=6.0mA
Lamp Current	IL	5.5	6.0	6.5	mArms	*1)
Inverter Frequency	FI	40	--	60	kHz	*2)
Lamp Initial Voltage	VS	1330	--		Vrms	Ta=25°C
		1730	--		Vrms	Ta=0°C

(b) LAMP LIFE – TIME

Harrison Lamp:

ITEM	IL at 2.0 mA	IL at 6.0 mA	IL at 6.5 mA	UNIT	REMARK
LAMP LIFE-TIME (LT)	Min. 15,000	Min. 15,000	Min.10,000	hr	Continuous Operation*3)
Turn-on and turn-off Operation	--	Min.100,000	--	times	Continuous Operation *4)

*1)Measure method : galvanometer connect to low voltage

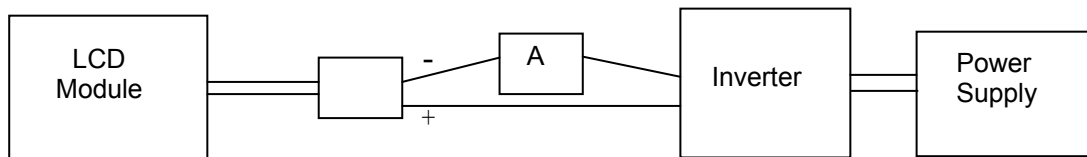

*2) Frequency in this range can make the characteristics of electric and optics maintain in +/- 10% except hue.

Lamp frequency of inverter may produce interference with horizontal synchronous frequency, and this may cause horizontal beat on the display. Therefore, please adjust lamp frequency, and keep inverter as far from module as possible or use electronic shielding between inverter and module to avoid the interference.

Under optimum operate frequency range (50~80 KHz), will not effect panel life-time and reliability .

*3) Definition of the lamp life time :

- a. Luminance (L) under 50% of specification starting lamp voltage
- b. Starting Lamp Voltage: over130% of the initial value. Ta=25°C

*4) For keeping good lighting situation, when design the inverter, it must be considered that the voltage large than starting lamp voltage.

4. Connector Interface PIN & Function

(a) CN1 (Interface signal)

Outlet connector: FI-XB30SL-HF10 (JAE)

Link connector: FI-X30H (JAE, Link Type)

Pin No.	SYMBOL	FUNCTION
1	Vss	Ground
2	Vin	+3.3V Power
3	Vin	+3.3V Power
4	V_EDID	EDID VCC
5	NC	Not Connection
6	CLK_EDID	EDID Clock
7	DATA_EDID	EDID Data
8	RO0M	minus signal of Odd channel 0(LVDS)
9	RO0P	plus signal of Odd channel 0(LVDS)
10	Vss	Ground
11	RO1M	minus signal of Odd channel 1(LVDS)
12	RO1P	plus signal of Odd channel 1(LVDS)
13	Vss	Ground
14	RO2M	minus signal of Odd channel 2(LVDS)
15	RO2P	plus signal of Odd channel 2(LVDS)
16	Vss	Ground
17	ROCLKM	minus signal of Odd clock channel (LVDS)
18	ROCLKP	plus signal of Odd clock channel (LVDS)
19	Vss	Ground
20	RE0M	minus signal of Even channel 0(LVDS)
21	RE0P	plus signal of Even channel 0(LVDS)
22	Vss	Ground
23	RE1M	minus signal of Even channel 1(LVDS)
24	RE1P	plus signal of Even channel 1(LVDS)
25	Vss	Ground
26	RE2M	minus signal of Even channel 2(LVDS)
27	RE2P	plus signal of Even channel 2(LVDS)
28	Vss	Ground
29	RECLKM	minus signal of Even clock channel (LVDS)
30	RECLKP	plus signal of Even clock channel (LVDS)

(b) CN2 (BACKLIGHT)

Backlight-side connector: BHSR-02VS-1 (JST)

Inverter-side connector: SM02B-BHSS-1 (JST)

Pin No.	Symbol	Function
1	CTH	VBLH (High)
2	CTL	VBLL (Low)

[Note] : VBLH-VBLL=VL

5. INTERFACE TIMING CHART

(1)(a). LVDS input time sequence

Horizontal sequence

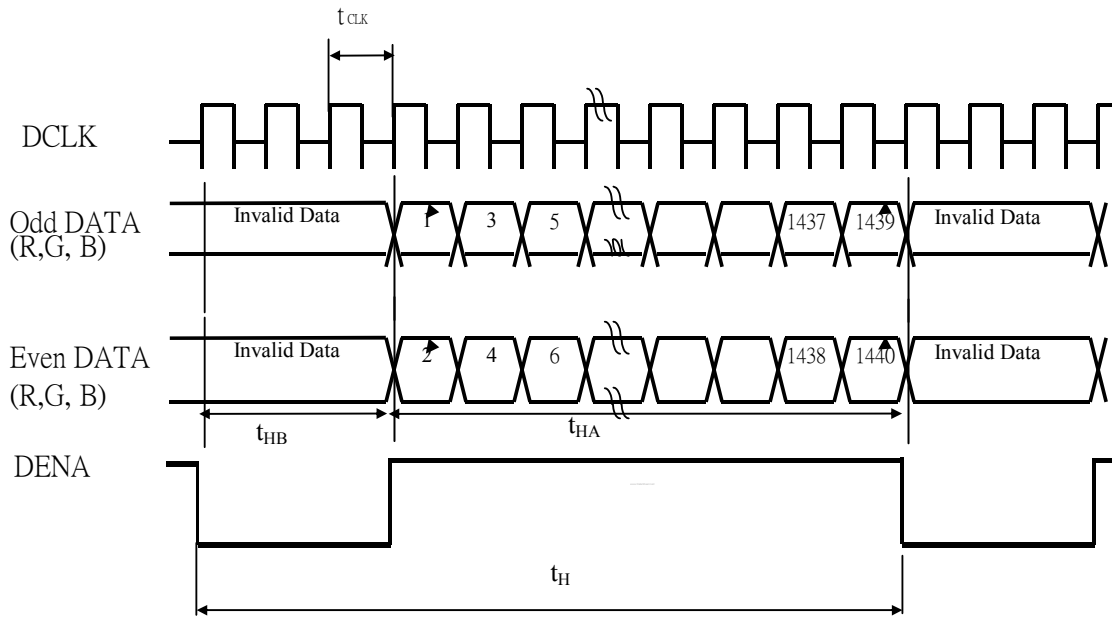

(b) LCD input time sequence

Vertical sequence

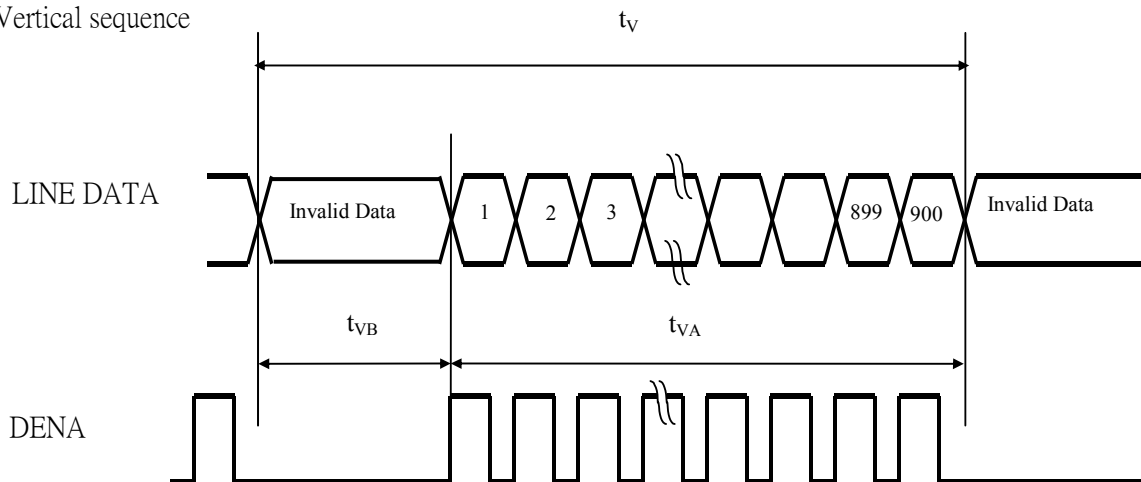

(2) Timing Chart

ITEM			SYMBOL	MIN	TYP	MAX	UNIT	
LCD Timing	DCLK		Frequency	f_{CLK}	41.5	44.375	54.00	MHZ
			Period	t_{CLK}	24.09	22.53	18.51	ns
	DENA	Horizontal	Horizontal total time	t_H	760	800	900	t_{CLK}
			Horizontal Active time	t_{HA}	720	720	720	t_{CLK}
			Horizontal Blank time	t_{HB}	40	80	180	t_{CLK}
		Vertical	Vertical total time	t_V	910	926	1000	t_H
			Vertical Active time	t_{VA}	900	900	900	t_H
			Vertical Blank time	t_{VB}	10	26	100	t_H

[Note]

*1) DENA (DATA ENABLE) usually is positive.

*2) During the whole blank period, DCLK should keep input.

(3) DATA mapping

Color	Input Data	R DATA						G DATA						B DATA					
		R5	R4	R3	R2	R1	R0	G5	G4	G3	G2	G1	G0	B5	B4	B3	B2	B1	B0
		MS B					LS B	MS B					LS B	MS B					LS B
Basic Color	Black	0	0	0	0	0	0	0	0	0	0	0	0	0	0	0	0	0	0
	Red(63)	1	1	1	1	1	1	0	0	0	0	0	0	0	0	0	0	0	0
	Green(63)	0	0	0	0	0	0	1	1	1	1	1	1	0	0	0	0	0	0
	Blue(63)	0	0	0	0	0	0	0	0	0	0	0	0	1	1	1	1	1	1
	Cyan	0	0	0	0	0	0	1	1	1	1	1	1	1	1	1	1	1	1
	Magenta	1	1	1	1	1	1	0	0	0	0	0	0	1	1	1	1	1	1
	Yellow	1	1	1	1	1	1	1	1	1	1	1	1	0	0	0	0	0	0
	White	1	1	1	1	1	1	1	1	1	1	1	1	1	1	1	1	1	1
RED	RED(0)	0	0	0	0	0	0	0	0	0	0	0	0	0	0	0	0	0	0
	RED(1)	0	0	0	0	0	1	0	0	0	0	0	0	0	0	0	0	0	0
	RED(2)	0	0	0	0	1	0	0	0	0	0	0	0	0	0	0	0	0	0
	RED(62)	1	1	1	1	1	0	0	0	0	0	0	0	0	0	0	0	0	0
	RED(63)	1	1	1	1	1	1	0	0	0	0	0	0	0	0	0	0	0	0
Green	Green(0)	0	0	0	0	0	0	0	0	0	0	0	0	0	0	0	0	0	0
	Green(1)	0	0	0	0	0	0	0	0	0	0	0	1	0	0	0	0	0	0
	Green(2)	0	0	0	0	0	0	0	0	0	0	1	0	0	0	0	0	0	0
	Green(62)	0	0	0	0	0	0	1	1	1	1	1	0	0	0	0	0	0	0
	Green(63)	0	0	0	0	0	0	1	1	1	1	1	1	0	0	0	0	0	0
Blue	Blue(0)	0	0	0	0	0	0	0	0	0	0	0	0	0	0	0	0	0	0
	Blue(1)	0	0	0	0	0	0	0	0	0	0	0	0	0	0	0	0	0	1
	Blue(2)	0	0	0	0	0	0	0	0	0	0	0	0	0	0	0	0	1	0
	Blue(62)	0	0	0	0	0	0	0	0	0	0	0	0	1	1	1	1	1	0
	Blue(63)	0	0	0	0	0	0	0	0	0	0	0	0	1	1	1	1	1	1

[Note]

1) Gray level:

Color(n) : n is level order; higher n means brighter level.

2) DATA:

1: high · 0: low

6. BLOCK DIAGRAM

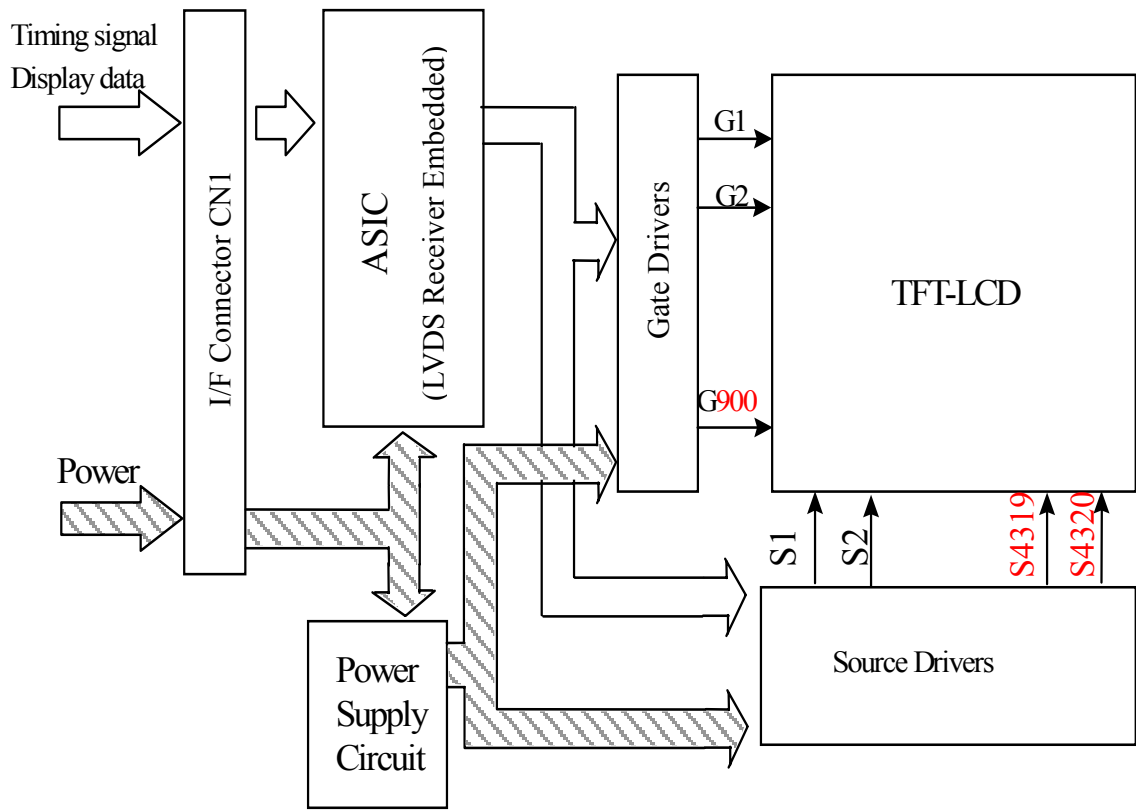

BACK LIGHT

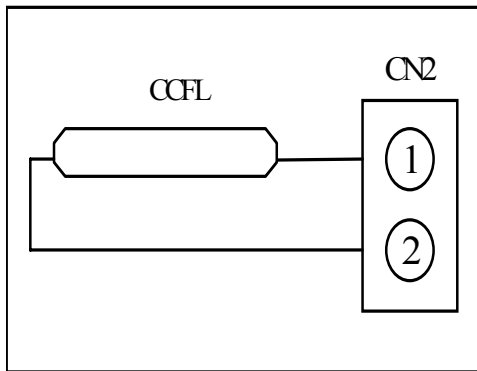

INVERTER CIRCUIT (OUT SIDE)

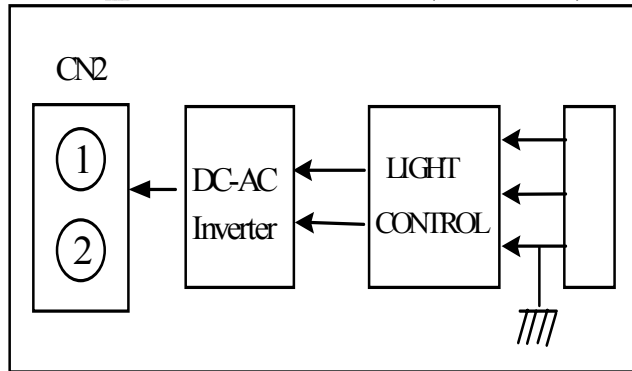

7. MECHANICAL SPECIFICATION

(1) Front side

The tolerance, not show in the figure, is $\pm 0.5\text{mm}$.

[Unit : mm]

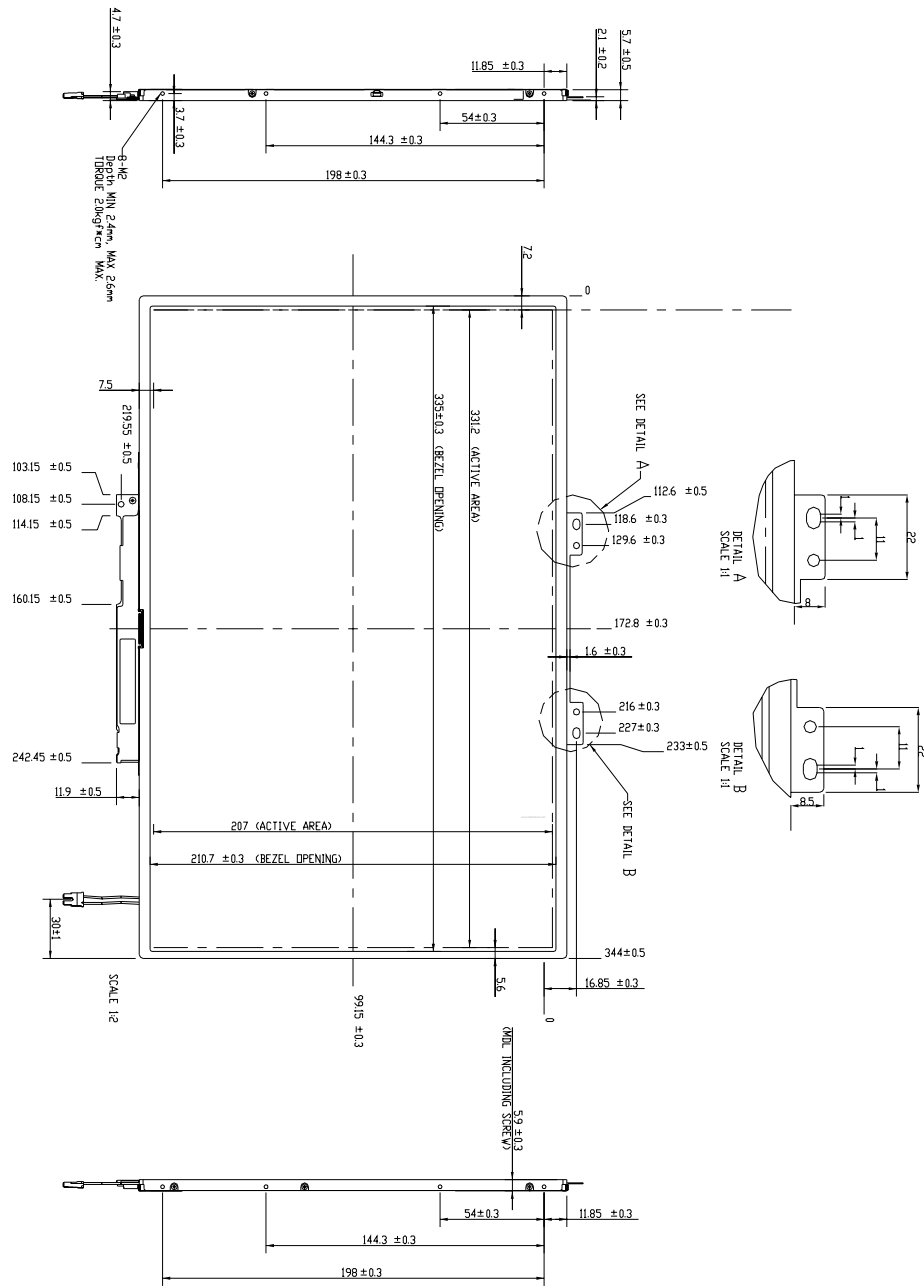

2) Rear side

The tolerance, not show in the figure, is $\pm 0.5\text{mm}$.

[Unit : mm]

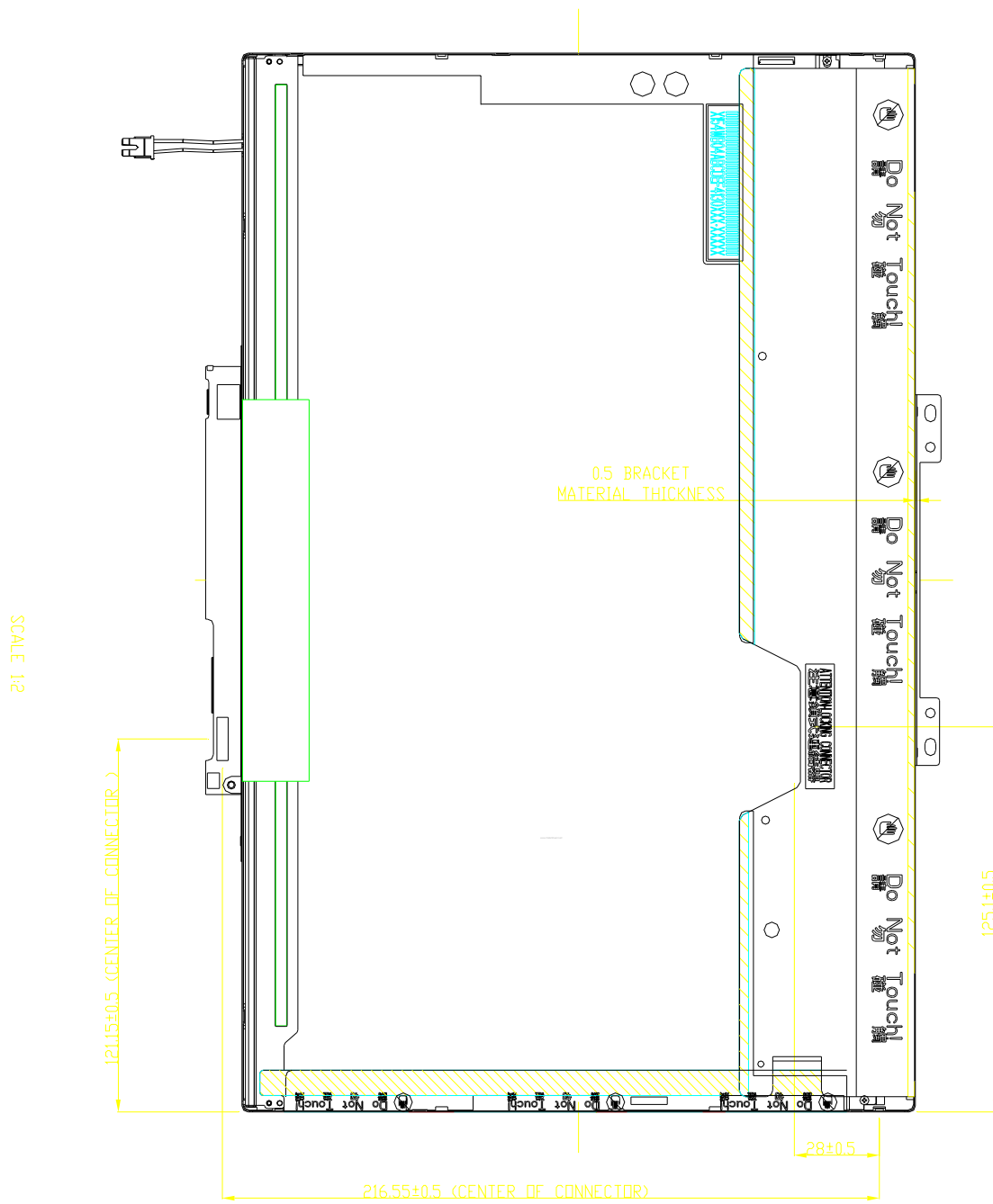

8. OPTICAL CHARACTERISTICS

Ta=25°C · VDD=3.3V

ITEM	SYMBOL	CONDITION	MIN.	TYP.	MAX.	UNIT	REMARK	
Contrast Ratio	CR	$\theta = \psi = 0^\circ$	350	400		--	*1)	
Luminance (5P)	L	$\theta = \psi = 0^\circ$	220	250		cd/m ²	*2)	
Uniformity(5P)	ΔL	$\theta = \psi = 0^\circ$	80			%	*2)	
Uniformity(13P)	ΔL	$\theta = \psi = 0^\circ$	65			%		
Response Time	Tr	$\theta = \psi = 0^\circ$		2.5	6	Ms	*4)	
	Tf	$\theta = \psi = 0^\circ$		5.5	10	Ms	*4)	
Image sticking	Tis	16 hours		-	20	Min	*5)	
Cross talk	CT	$\theta = \phi = 0^{*3}$			1	%	*6)	
View angle	Horizontal	ψ	CR \geq 10	50/-50	60/-60		°	*3)
	Vertical	θ		35/-45	45/-55		°	*3)
Color Temperature Coordinate	W	X	$\theta = \psi = 0^\circ$	0.283	0.313	0.343		*2)
		Y		0.299	0.329	0.359		
	R	X		0.565	0.595	0.625		
		Y		0.315	0.345	0.375		
	G	X		0.285	0.315	0.345		
		Y		0.532	0.562	0.592		
	B	X		0.125	0.155	0.185		
		Y		0.102	0.132	0.162		

These items are measured using BM-5A (TOPCON) under the dark room condition (no ambient light).
Measurement Condition: IL = 6.5 mA (SMB_DATA=FFH)

Inverter : SUMIDA / IV12139/T

Definition of these measurement items is as follows:

*1) Definition of Contrast Ratio

CR=ON (White) Luminance/OFF (Black) Luminance

***2) Definition of Luminance and Luminance uniformity**

Central luminance: The white luminance is measured at the center position “5” on the screen, see Fig.1 below.

5P Luminance (AVG): The white luminance is measured at measuring points 5、10、11、12、13, see Fig.1 below

5P Uniformity: $\Delta L = (L_{min} / L_{max}) \times 100\%$

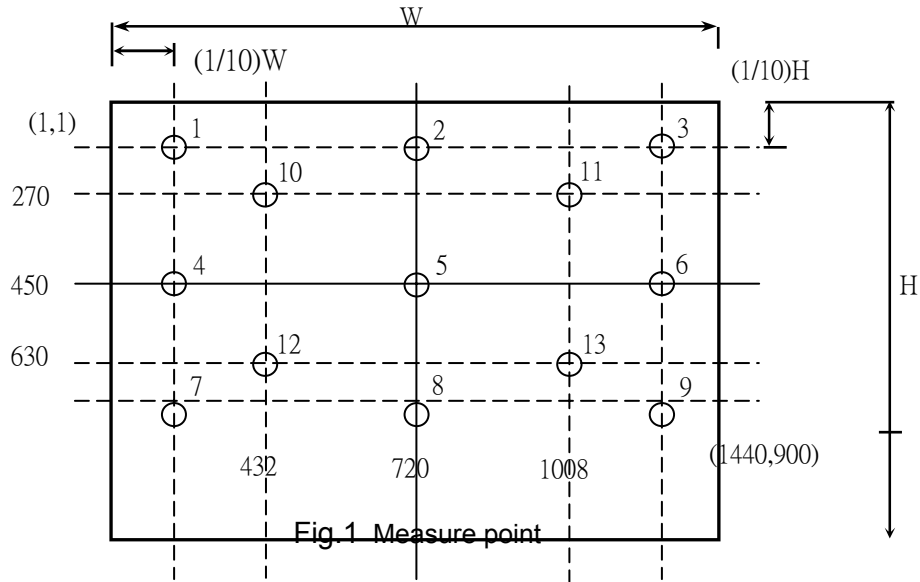

***3) Definition of view angle(θ , ψ)**

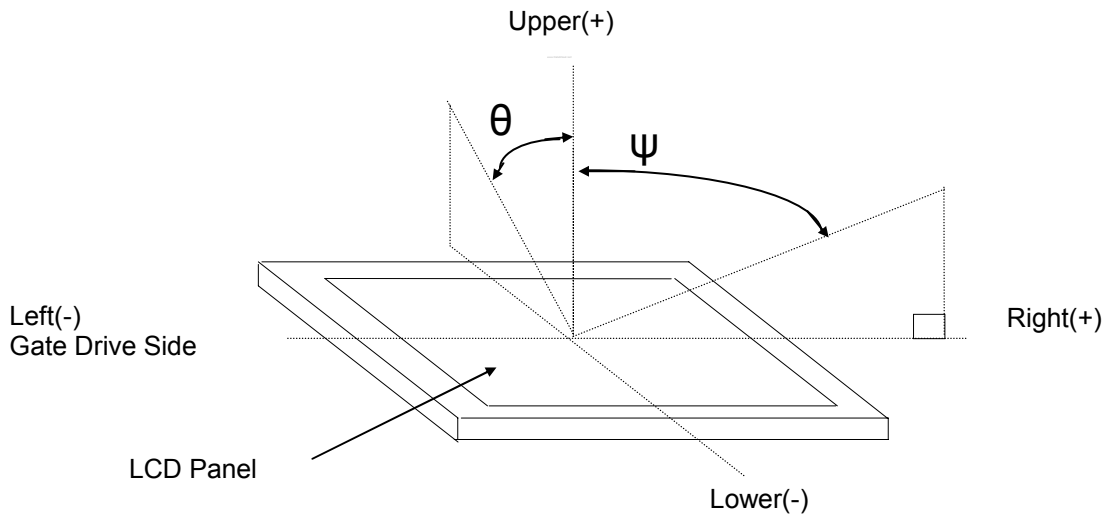

***4) Definition of response time**

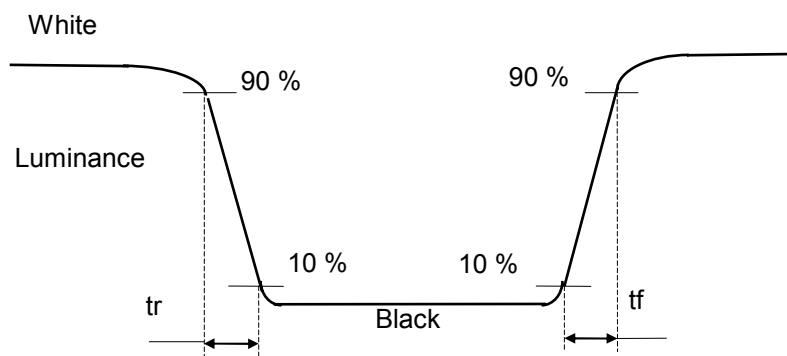

***5) Definition of image sticking**

Continuously display the test pattern shown in the figure below for 16 hrs.at 25°C.

To change the picture to gray pattern (gray 32 pattern), and the previous image shall not persist during 20 min .

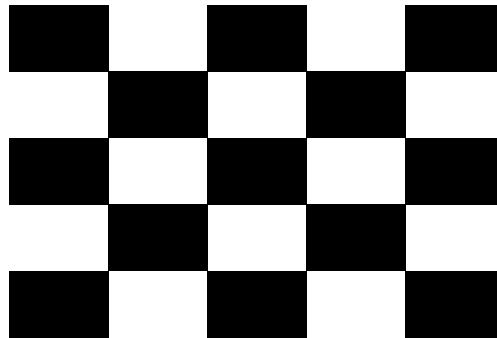

White : 63 Gray
Black : 0 Gray

***6) Crosstalk Modulation Ratio:**

$$CT = | Y_B - Y_A | / Y_{A \times} \times 100\%$$

Y_A 、 Y_B measure position and definition

Y_A means luminance at gray level 32(exclude gray level 0 pattern)

Y_B means luminance at gray level 32(include gray level 0 pattern)

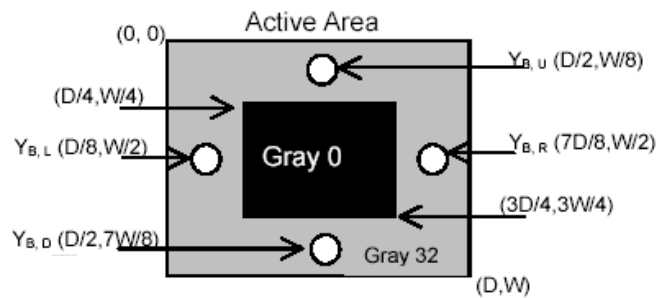
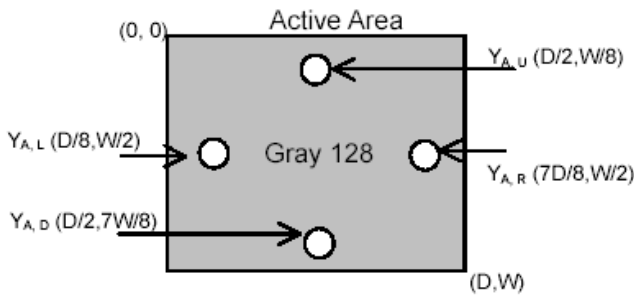

9. RELIABILITY TEST CONDITIONS

(1) Temperature and Humidity

TEST ITEMS	CONDITIONS
High Temperature Operation	50° C ; 250Hrs
High Temperature Storage	65° C ; 250Hrs
High Temperature High Humidity Operation	40° C ; 95% RH ; 250Hrs
High Temperature High Humidity Storage	60° C ; 95% RH ; 48 Hrs
Low Temperature Operation	0° C ; 250 Hrs
Low Temperature Storage	-25° C ; 250 Hrs
Thermal Shock	-40° C (30 Mins)~65° C (30 Mins) , Ramp<20° C , 100 CYCLE
Temperature & Pressure Storage	0° C ; 260hPa(about 10000m) , 24 Hrs

(2) Shock & Vibration

TEST ITEMS	CONDITIONS
Shock (Non-Operation)	Shock level : 2450m/s ² (250G), Waveform : half sinusoidal wave, 2ms, 6 axis (± X, ± Y, ± Z) per cycle
Vibration (Non-Operation)	Vibration level : 14.7m/s ² (1.5G), sinusoidal wave (each x,y,z axis : 1hr, total 3hrs) Frequency range : 5~500 Hz Sweep speed : 0.5 Octave/min.

(3) ESD

	Surface discharge(Panel display area · Frame · PWB · Panel back side)		Electrics capacity of Connector
	Contact	Air	Contact
Capacity	150 pF	150 pF	200 pF
Resistance	330 Ω	330 Ω	0 Ω
Voltage	±8kV	±8kV/±15kV	±250 V
Interval	1 sec	1 sec	1 sec
Times(single point)	25	25	1

(4) MTBF without B/L: 200,000 Hrs (min) lifetime.

(5) Judgment standard

The judgment of the above test should be made as follow:

Pass : Normal display image with no obvious non-uniformity and no line defect.

Partial transformation of the module parts should be ignored.

Fail : No display image, obvious non-uniformity, or line defects.