



# Chunghwa Picture Tubes, Ltd.

## Technical Specification

To :

Date : 2008/04/14

*CPT TFT-LCD*  
**CLAA154WP05A**

**ACCEPTED BY :**

APPROVED BY	CHECKED BY	PREPARED BY
Ronald Huang	Roger Liu	Carol Shen

Prepared by :

**Product Planning Management General Div**

**Sales & Marketing General Departments**

**CHUNGHWA PICTURE TUBES, LTD.,**

1127 Hopin Rd., Padeh, Taoyuan, Taiwan 334, R.O.C.  
TEL: +886-3-3675151 FAX: +886-3-377-3003

Doc.No:	CLAA154WP05AN-STUDIO-V1-2009/03/02	Issue Date:	2009/03/02
---------	------------------------------------	-------------	------------

## 1. OVERVIEW

CLAA154WP05AN is 15.4" color TFT-LCD (Thin Film Transistor Liquid Crystal Display) module composed of LCD panel, LVDS driver ICs, control circuit and backlight. By applying 6 bit digital data, 1440×900, 262K-color images are displayed on the 15.4" diagonal screen. Inverter for backlight is not included in this module. General specification are summarized in the following table:

ITEM	SPECIFICATION
Display Area(mm)	331.56(H) x 207.225(V) (15.4-inch diagonal)
Number of Pixels	1440x 3(H) x 900(V)
Pixel Pitch(mm)	0.23025(H) x 0.23025(V)
Color Pixel Arrangement	RGB vertical stripe
Display Mode	normally white TN
Number of Colors	262,144 colors
Optimum Viewing Angle	6 o'clock
Brightness(cd/m <sup>2</sup> )	185 cd/m <sup>2</sup> (5 point) @6mA(typ.)
View angle	-40°~ 40° / -40°~20° (typ)
Power consumption(W)	6.7 W max
Module Size(mm)	344.5(W)×222.5(H)×6.0(D)(max.)
Module Weight(g)	570(Max.)
Surfcae treatment	Anti-Glare (25% Haze ) ; Hardness: 3H
Backlight Unit	1 tube ,Edge light (Bottom)

The LCD Products listed on this document are not suitable for use of aerospace equipment, submarine cables, and nuclear reactor control system and life support systems. If customers intend to use these LCD products for above application or not listed in "Standard" as follows, please contact our sales people in advance.

Standard: Computer, Office equipment, Communication equipment, Test and Measurement equipment, Machine tool, Industrial robot, Audio and Visual equipment, Other consumer products.

## 2. ABSOLUTE MAXIMUM RATINGS

ITEM	SYMBOL	MIN.	MAX.	UNIT	REMARK
Power Supply Voltage for LCD	VCC	0	4.0	V	
Lamp voltage	VL	680	900	V <sub>rms</sub>	
Lamp current	West/ Harrison	IL	2	mArms	*1). 2)
Lamp frequency		FL	40	80	kHz
Operation Temperature	Top	0	50	°C	*3). 4). 5). 6)
Storage Temperature	Tstg	-25	65	°C	*3). 4). 5)
Delayed Discharge Time	TD	--	1	sec	*7)

The following are maximum values which, if exceeded, may cause faulty operation or damage to the unit.

**[Note]**

- \*1) Product life-time related to lamp current, pls operate the production follow statement at page 8
- \*2) When lamp current over the definition of absolute maximum, product life-time will decay rapidly or operate unusual.
- \*3) The relative temperature and humidity range are as below sketch, 90%RHMax. ( $T_a \leq 40^\circ\text{C}$ )
- \*4) The maximum wet bulb temperature  $\leq 39^\circ\text{C}$  ( $T_a > 40^\circ\text{C}$ ) and without dewing
- \*5). If you use the product in a environment which over the definition of temperature and humidity too long to effect the result of eye-atching.
- \*6) If you operate the product in normal temperature range, the center surface of panel should be under  $60^\circ\text{C}$ .  
 Humidity :  
 Humidity  $\leq 85\%RH$  without condensation.  
 Relative Humidity  $\leq 90\%$  ( $T_a \leq 40^\circ\text{C}$ )  
 Wet Bulb Temperature  $\leq 39^\circ\text{C}$  ( $T_a \geq 40^\circ\text{C}$ )
- \*7) Delayed discharge time test condition:  
 starting lamp voltage = 1650V<sub>rms</sub>  
 Before test TD, lamp should operate at least 1min. , and lamp current should follow typical lamp current specification. To place panel at room temp. ( $25 \pm 2^\circ\text{C}$ ) below for 24hr, and then to measue TD with the same starting lamp voltage in dark room.

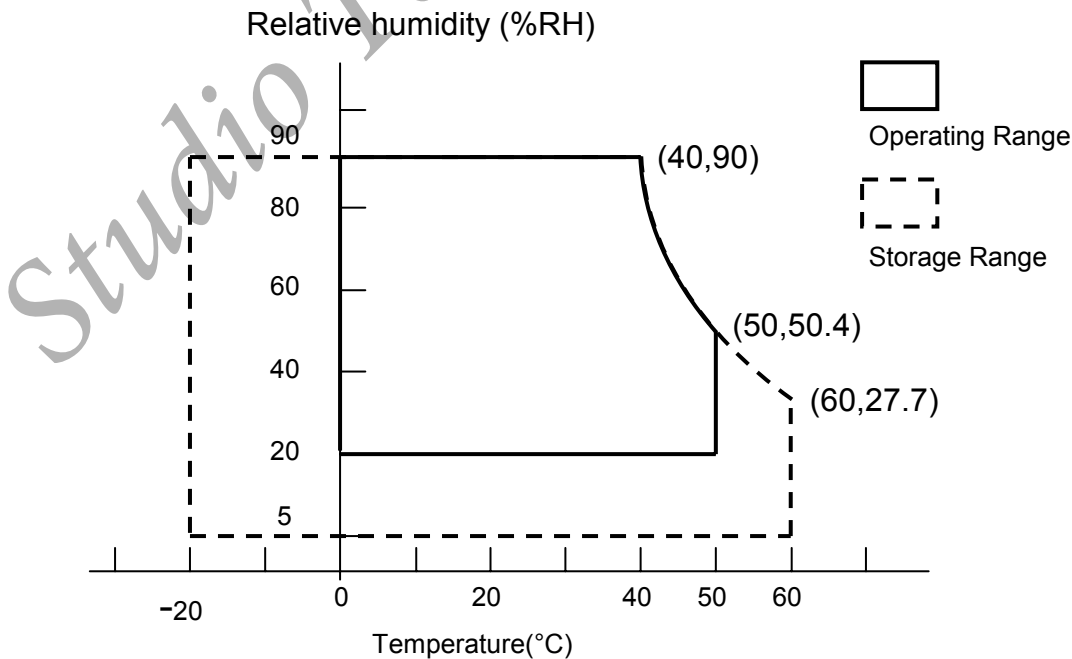

### 3. ELECTRICAL CHARACTERISTICS

#### 3.1 TFT-LCD

Ta=25°C

TEM	SYMBOL	MIN	TYP	MAX	UNIT	REMARK
LCD POWER VOLTAGE	VCC	3.0	3.3	3.6	V	[Note 1]
LCD POWER CURRENT	ICC	-	500	600	mA	[Note 2]
Rush CRRENT	Irush	-	-	3	A	[Note 4]
LOGIC INPUT VOLTAGE (LVDS: IN+,IN-) [Note 3]	INPUT VOLTAGE	VIN	0	-	VCC	V
	COMMON VOLTAGE	VCM	1.125	1.25	1.375	V
	DIFFERENTIAL INPUT VOLTAGE	VID	250	350	450	mV
	THRESHOLD VOLTAGE (HIGH)	VTH	-	-	100	mV
	THRESHOLD VOLTAGE (LOW)	VTL	-100	-	-	mV
DIFFERENTIAL INPUT VOLTAGE TOLERANCE	$\Delta$ VID	-	-	35	mV	When VCM = +1.2V
COMMON VOLTAGE TOLERANCE	$\Delta$ VCM	-	-	35	mV	

#### [Note]

\*1)

- Power sequence(VCC turn on conditions) :

$$\begin{array}{ll}
 t1 \leq 10 \text{ ms} & 1\text{sec} \leq t5 \\
 0.01\text{ms} < t2 \leq 50\text{ms} & 200\text{ms} \leq t6 \\
 0.01\text{ms} < t3 \leq 50\text{ms} & 200\text{ms} \leq t7 \\
 0.01\text{ms} < t4 \leq 10 \text{ ms} & -
 \end{array}$$

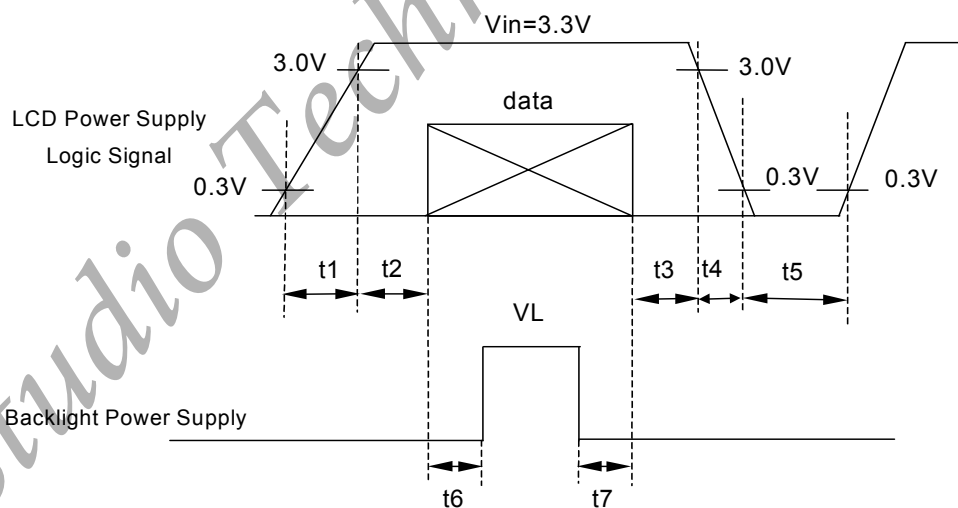

Data: RGB DATA, DCLK, HD, VD, DENA

- VCC dip conditions:
  - 1) When  $3.0 > VCC \geq 2.7V$ ,  $t_d \leq 10 \text{ ms}$
  - 2) When  $VCC < 2.7V$ , it works abnormal that must reset power.  
VCC dip conditions should follow VCC turn on conditions.

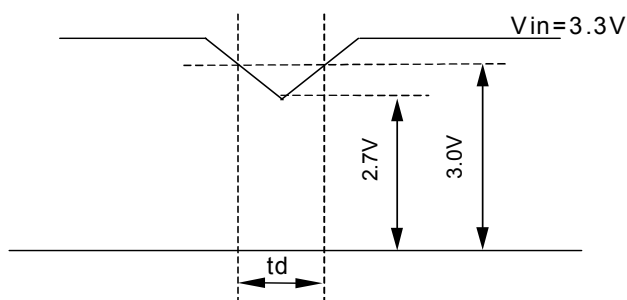

\*2) Typical value is 0~63 gray level.(horizontal line Pattern)  
 900 line mode ,  $VCC= +3.3V$   
 Circuit condition(Typ.)  
 $VCC=3.3 V$  ,  $f_V=60 Hz$   $f_H=55.56 kHz$  ,  $f_{CLK}=44.375 MHz$

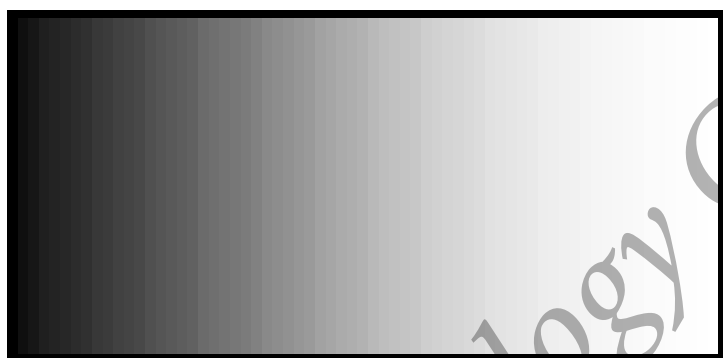

64-Gray :  
 0 ~ 63Gray

- Maximum value is measured when displaying horizontal gray scale line pattern

$VCC=3.3 V$  ,  $f_V=60 Hz$   $f_H=55.56 kHz$  ,  $f_{CLK}=44.375 MHz$

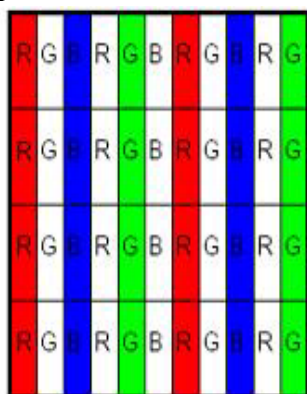
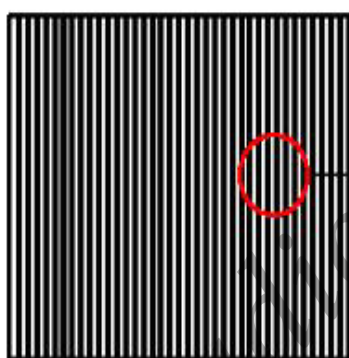

\*3) Irush Measurement Condition

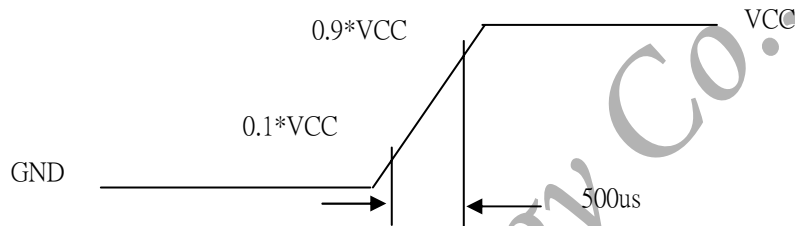
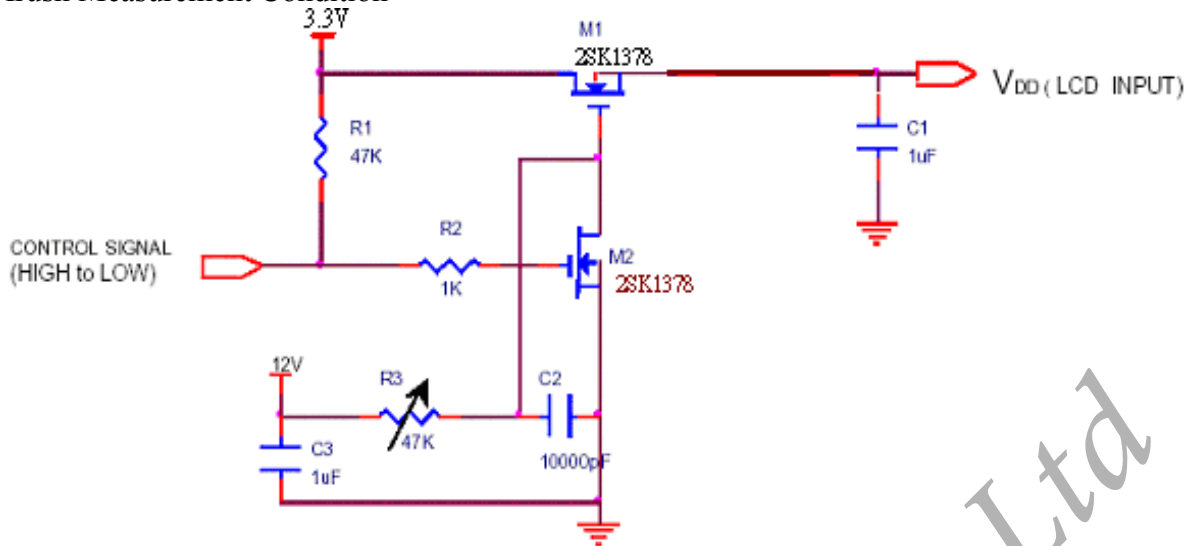

\*4) LVDS Signal definition :

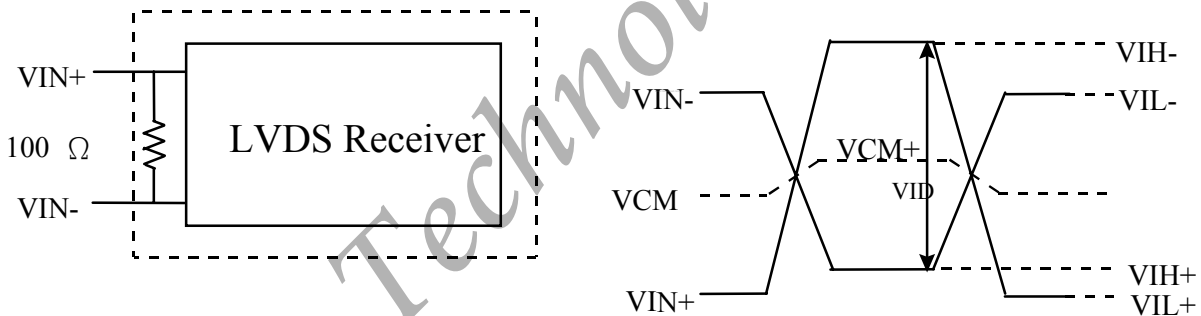

$$\begin{aligned}
 VID &= VIN_+ - VIN_- \\
 \Delta VCM &= |VCM_+ - VCM_-| \\
 \Delta VID &= |VID_+ - VID_-| \\
 VID_+ &= |VIH_+ - VIH_-| \\
 VID_- &= |VIL_+ - VIL_-| \\
 VCM &= (VIN_+ + VIN_-) / 2 \\
 VCM_+ &= (VIH_+ + VIH_-) / 2 \\
 VCM_- &= (VIL_+ + VIL_-) / 2
 \end{aligned}$$

VIN<sub>+</sub> = Positive differential DATA & CLK Input  
 VIN<sub>-</sub> = Negative differential DATA & CLK Input

3.2 Backlight \*1)

(A) Electrical Characteristics

Ta=25°C

ITEM	SYMBOL	MIN	TYP	MAX	UNIT	REMARK
Lamp Voltage	VL	657	730	803	Vrms	IL=6.0mA
Lamp Current	IL	5.5	6.0	6.5	mArms	*2)
Inverter Frequency	FI	50		80	kHz	*3)
Starting Lamp Voltage	VS	1460			Vrms	Ta=25°C
		1730			Vrms	Ta=0°C

(B) Lamp Life Time

ITEM	IL at 3.0 mA	IL at 6.0 mA	IL at 6.5 mA	UNIT	REMARK
Lamp Life Time	--	Min. 10,000	--	hr	Continuous Operation*4)
Turn-on and Turn-off Operation	--	Min.100,000	--	time	Continuous Operation*5)

[Note]

\*1) Invert vender : SUMIDA , mode : IV11145T

If the waveform of light up-driving is asymmetric, the distribution of mercury inside the lamp tube will become unequally or will deplete the Ar gas in it. Then it may cause the abnormal phenomenon of lighting-up. Therefore, designers have to try their best to fulfill the conditions under the inverter designing-stage as below:

- The degrees of unbalance : < 10%
- The ratio of wave height : <  $\sqrt{2} \pm 10\%$

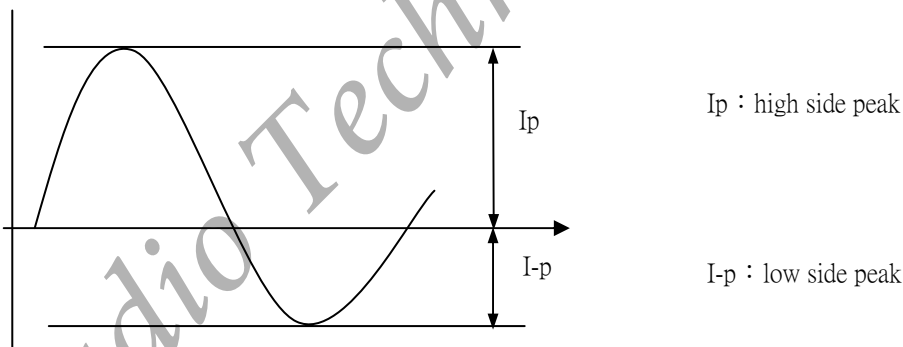

A : The degrees of unbalance =  $| Ip - I-p | / Irms \times 100 (\%)$

B : The ratio of wave height =  $Ip \text{ (or } I-p) / Irms$

\*2) Lamp Current measurement method (The current meter is inserted in cold line)

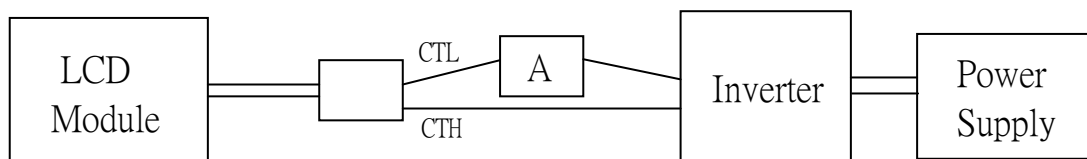

\*3)

- Frequency in this range can mala the characteristics of electric and optics maintain in +/- 10% except hue.

- b. Under optimum operate frequency range (50~60 kHz), have better electrical and optical characterics.
- c. Lamp frequency of inverter may produce interference with horizontal synchronous frequency, and this may cause horizontal beat on the display. Therefore, please adjust lamp frequency, and keep inverter as far from module as possible or use electronic shielding between inverter and module to avoid the interference.
- d. Under optimum operate frequency range (40~80 kHz), will not effect panel life-time and reliability .

\*4) Definition of the lamp life time :

- a. Luminance (L) under 50% of specification starting lamp voltage
- b. Starting Lamp Voltage > 130 % \* initial value (the room temperature)

\*5) The condition of Turn-on and Turn-off operation is as below:

- a. Lamp current is 6.0mA
- b. Frequency is 10 sec.(on)/10 sec.(off)
- c. Repeat it for 100,000 times
- d. The lamp hue variation must smaller than 0.03
- e. It should not have motion fail when starting lamp voltage is lower than 130% of the initial value.
- f. the lamp luminance > initial value\* 50%

Studio Technology Co., Ltd



## 4. INTERFACE PIN CONNECTION

### 4.1 CN1

Outlet connector: FI-XB30SL-HF10 (JAE)

Plug connector: FI-X30H (JAE)

Pin No.	REMARK	FUNCTION
1	GND	Ground
2	VIN	+3.3V Power
3	VIN	+3.3V Power
4	V_EDID	EDID VCC
5	NC	Not Connection
6	CLK_EDID	EDID Clock
7	DATA_EDID	EDID Data
8	RO0N	minus signal of Odd channel 0(LVDS)
9	RO0P	plus signal of Odd channel 0(LVDS)
10	Vss	Ground
11	RO1N	minus signal of Odd channel 1(LVDS)
12	RO1P	plus signal of Odd channel 1(LVDS)
13	Vss	Ground
14	RO2N	minus signal of Odd channel 2(LVDS)
15	RO2P	plus signal of Odd channel 2(LVDS)
16	Vss	Ground
17	ROCLKN	minus signal of Odd clock channel (LVDS)
18	ROCLKP	plus signal of Odd clock channel (LVDS)
19	Vss	Ground
20	RE0N	minus signal of Even channel 0(LVDS)
21	RE0P	plus signal of Even channel 0(LVDS)
22	Vss	Ground
23	RE1N	minus signal of Even channel 1(LVDS)
24	RE1P	plus signal of Even channel 1(LVDS)
25	Vss	Ground
26	RE2N	minus signal of Even channel 2(LVDS)
27	RE2P	plus signal of Even channel 2(LVDS)
28	Vss	Ground
29	RECLKN	minus signal of Even clock channel (LVDS)
30	RECLKP	plus signal of Even clock channel (LVDS)

### 4.2 CN2 (BACKLIGHT)

Backlight-side connector: BHSR-02VS-1 (JST)

Inverter-side connector: SM02B-BHSS-1 (JST)

PIN #	SYMBOL	FUNCTION
1	CTH	VBLH (High voltage)
2	CTL	VBLL (Low voltage)

[Note] : VBLH-VBLL=VL

### 5. INTERFACE TIMING

#### 5.1 LVDS input time sequence

##### (a) Horizontal sequence

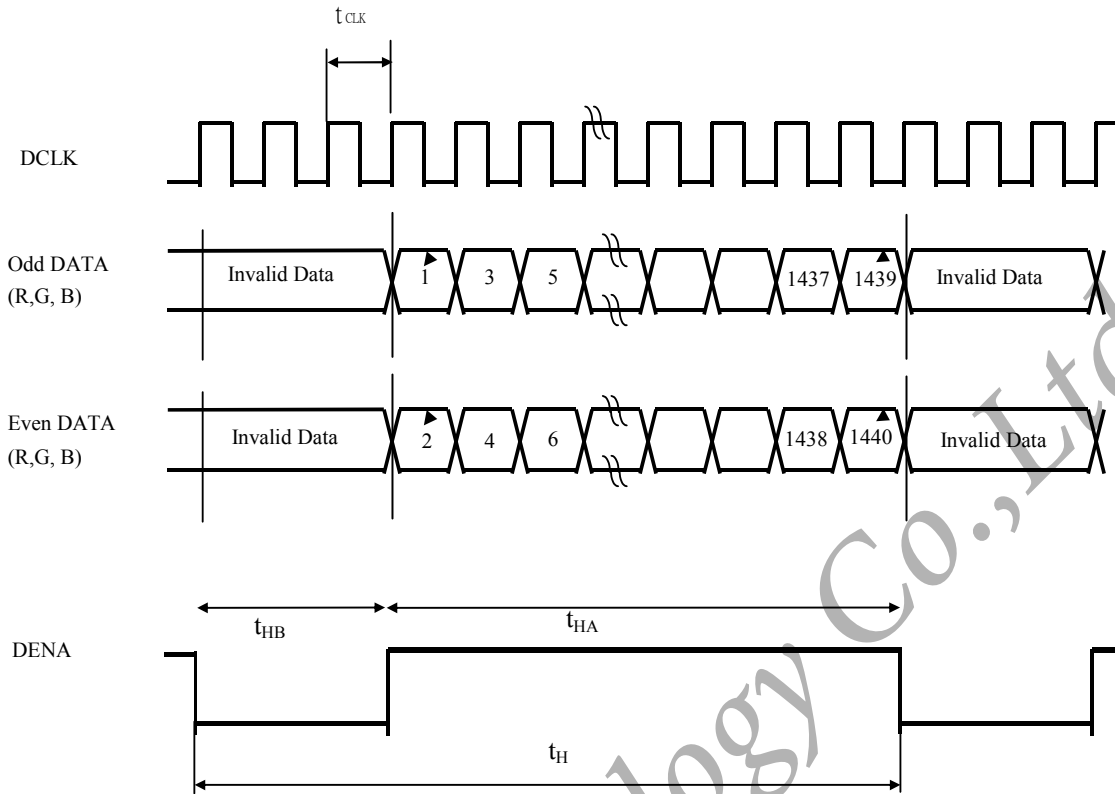

##### (b) Vertical sequence

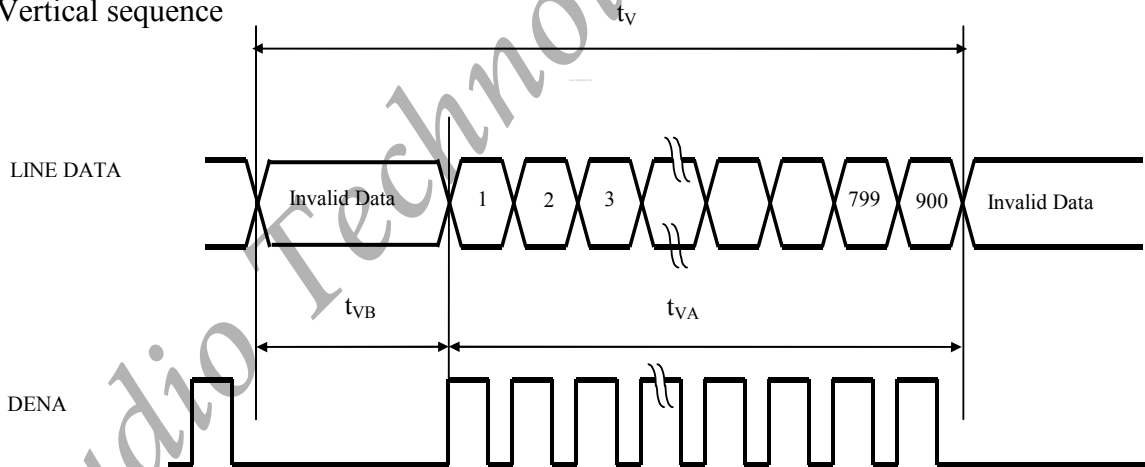

#### 5.2 Timing Chart

ITEM		SYMBOL	MIN	TYP	MAX	UNIT		
LCD Timing	DCLK	Frequency	$f_{CLK}$	41.5	44.375	54.00	MHz	
		Period	$t_{CLK}$	24.09	22.53	18.51	ns	
	DENA	Horizontal	Horizontal total time	$t_H$	760	800	900	$t_{CLK}$
			Horizontal Active time	$t_{HA}$	720	720	720	$t_{CLK}$
			Horizontal Blank time	$t_{HB}$	40	80	180	$t_{CLK}$
	DENA	Vertical	Vertical total time	$t_v$	910	926	1000	$t_H$
			Vertical Active time	$t_{vA}$	900	900	900	$t_H$
Vertical Blank time			$t_{vB}$	10	26	100	$t_H$	

[Note]

\*1) DENA (DATA ENABLE) usually is positive.

\*2) During the whole blank period, DCLK should keep input.

5.3 COLOR DATA ASSIGNMENT

Color	Input Data	R DATA						G DATA						B DATA					
		R5	R4	R3	R2	R1	R0	G5	G4	G3	G2	G1	G0	B5	B4	B3	B2	B1	B0
		MS B					LS B	MS B					LS B	MS B					LS B
Basic Color	Black	0	0	0	0	0	0	0	0	0	0	0	0	0	0	0	0	0	0
	Red(63)	1	1	1	1	1	1	0	0	0	0	0	0	0	0	0	0	0	0
	Green(63)	0	0	0	0	0	0	1	1	1	1	1	1	0	0	0	0	0	0
	Blue(63)	0	0	0	0	0	0	0	0	0	0	0	0	1	1	1	1	1	1
	Cyan	0	0	0	0	0	0	1	1	1	1	1	1	1	1	1	1	1	1
	Magenta	1	1	1	1	1	1	0	0	0	0	0	0	1	1	1	1	1	1
	Yellow	1	1	1	1	1	1	1	1	1	1	1	1	0	0	0	0	0	0
	White	1	1	1	1	1	1	1	1	1	1	1	1	1	1	1	1	1	1
RED	RED(0)	0	0	0	0	0	0	0	0	0	0	0	0	0	0	0	0	0	0
	RED(1)	0	0	0	0	0	1	0	0	0	0	0	0	0	0	0	0	0	0
	RED(2)	0	0	0	0	1	0	0	0	0	0	0	0	0	0	0	0	0	0
	RED(62)	1	1	1	1	1	0	0	0	0	0	0	0	0	0	0	0	0	0
	RED(63)	1	1	1	1	1	1	0	0	0	0	0	0	0	0	0	0	0	0
	Green	Green(0)	0	0	0	0	0	0	0	0	0	0	0	0	0	0	0	0	0
Green(1)		0	0	0	0	0	0	0	0	0	0	0	1	0	0	0	0	0	0
Green(2)		0	0	0	0	0	0	0	0	0	0	1	0	0	0	0	0	0	0
Green(62)		0	0	0	0	0	0	1	1	1	1	1	0	0	0	0	0	0	0
Green(63)		0	0	0	0	0	0	1	1	1	1	1	1	0	0	0	0	0	0
Blue		Blue(0)	0	0	0	0	0	0	0	0	0	0	0	0	0	0	0	0	0
	Blue(1)	0	0	0	0	0	0	0	0	0	0	0	0	0	0	0	0	0	1
	Blue(2)	0	0	0	0	0	0	0	0	0	0	0	0	0	0	0	0	1	0
	Blue(62)	0	0	0	0	0	0	0	0	0	0	0	0	1	1	1	1	1	0
	Blue(63)	0	0	0	0	0	0	0	0	0	0	0	0	1	1	1	1	1	1

[Note]

\*1) Definition of gray scale:

Color (n): n indicates gray scale level; larger n means brighter level.

\*2) Data: 1-High, 0-Low.

### 6. BLOCK DIAGRAM

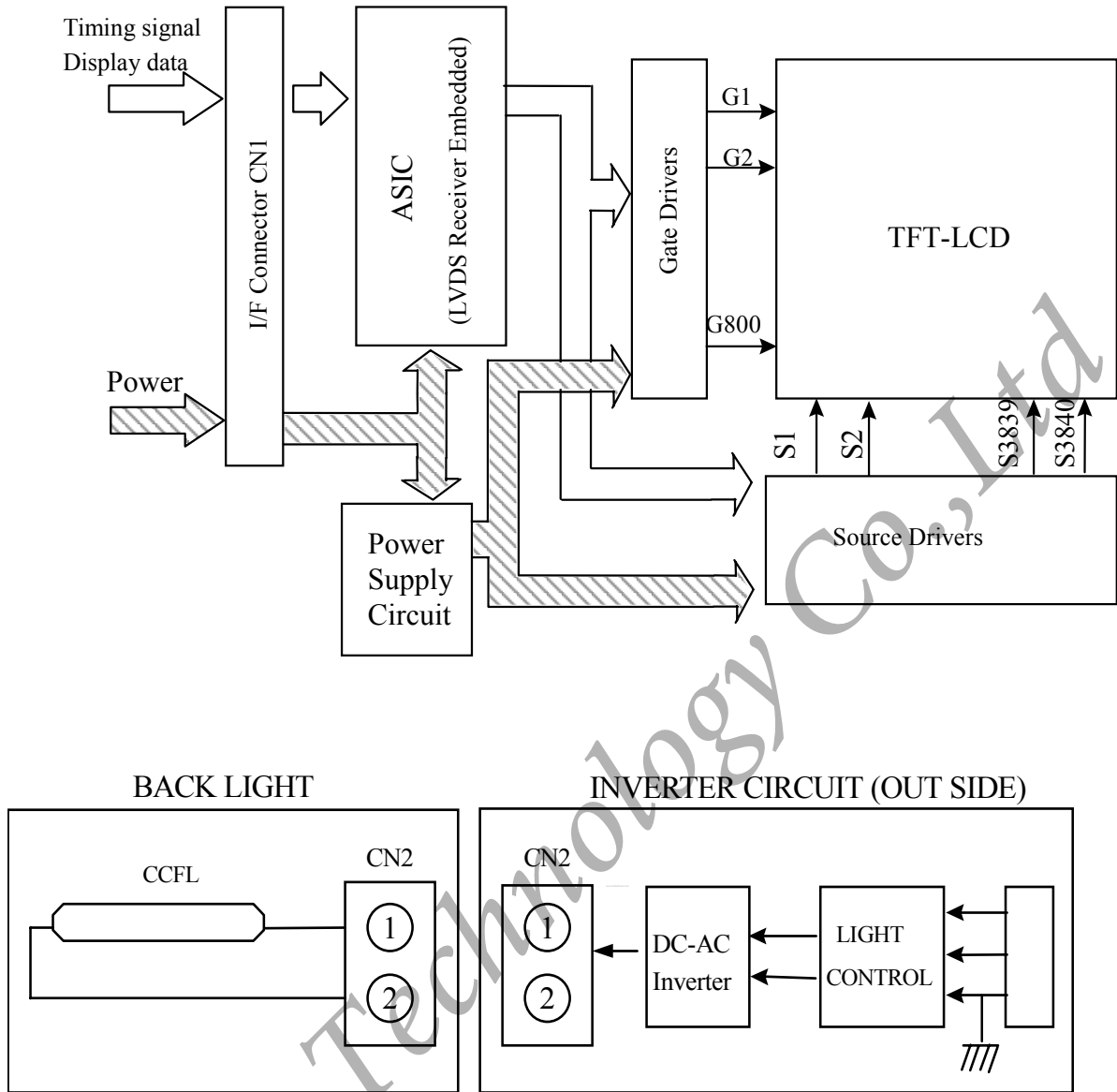



7.2 Rear side (Tolerance is  $\pm 0.5\text{mm}$  unless noted)

[Unit: mm]

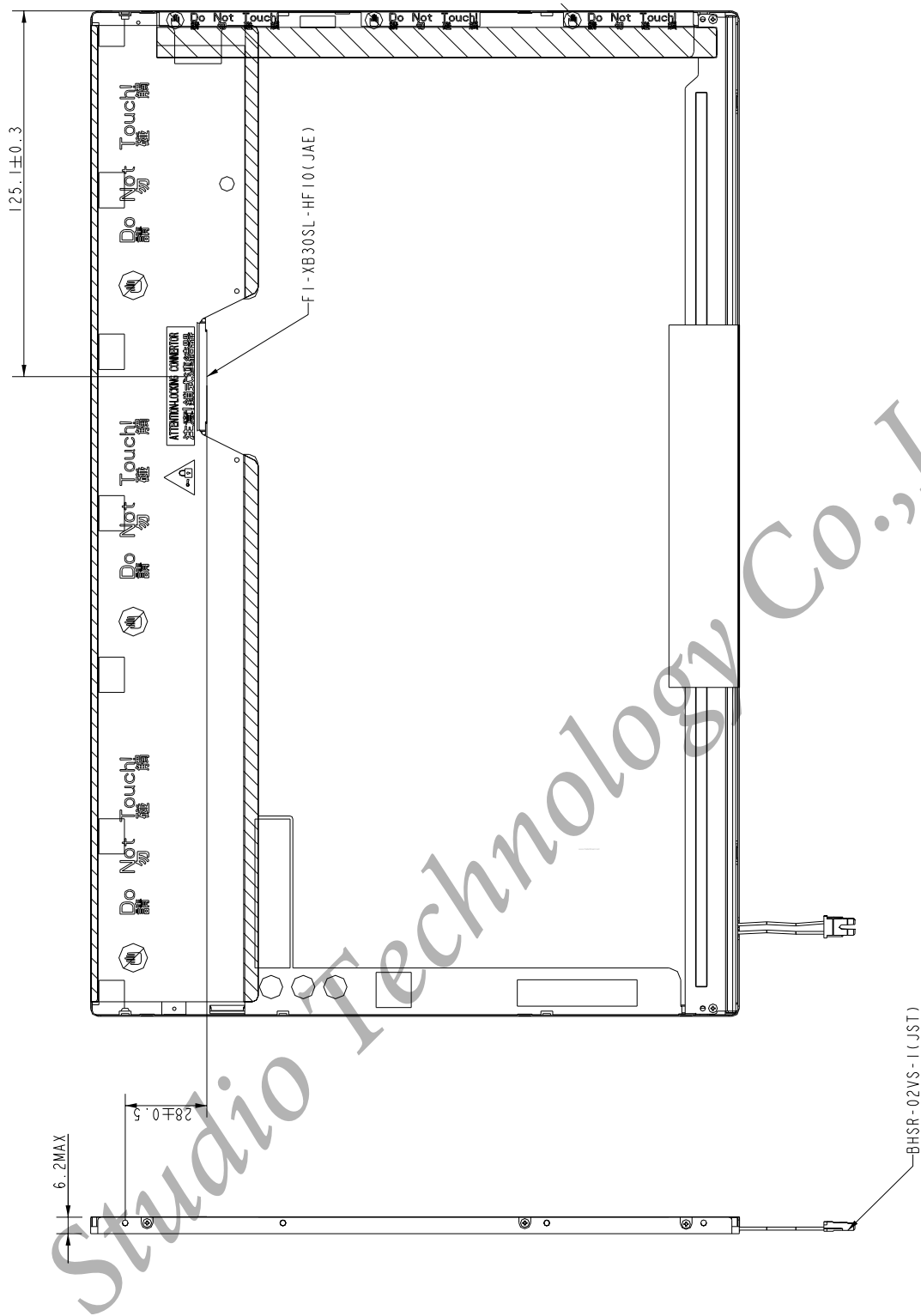

## 8.OPTICAL CHARACTERISTICS

Ta = 25°C, VCC=5.0V

ITEM	SYMBOL	CONDITION	MIN.	TYP.	MAX.	UNIT	REMARK	
Contrast (CEN)	CR	$\theta = \psi = 0^\circ$	300	500	--	--	*1)	
5P Luminance (AVG)	L	$\theta = \psi = 0^\circ$	150	185	--	cd/m <sup>2</sup>	*2)	
5P Uniformity	$\Delta L$	$\theta = \psi = 0^\circ$	80		--	%	*2)	
Response Time	Tr	$\theta = \psi = 0^\circ$	--	4	6	ms	*4)	
	Tf	$\theta = \psi = 0^\circ$	--	6	10	ms		
Image sticking	Tis	2 hours	--	--	2	sec	*5)	
View angle	Horizontal	$\psi$	$CR \geq 10$	35/-35	40/-40	--	Deg.	*3)
	Vertical	$\theta$		15/-35	20/-40	--	Deg.	
Color Coordinates	White	X	$\theta = \psi = 0^\circ$	0.283	0.313	0.343	--	--
		Y		0.299	0.329	0.359		
	Red	X		0.556	0.586	0.616		
		Y		0.316	0.346	0.376		
	Green	X		0.281	0.311	0.341		
		Y		0.534	0.564	0.594		
	Blue	X		0.124	0.154	0.184		
		Y		0.101	0.131	0.161		

**[Note]**

These items are measured using BM-5A (TOPCON) under the dark room condition (no ambient light).

Measurement Condition: IL=6.0mA

Inverter: SUMIDA / IV11145T.

Definition of these measurement items is as follows:

\*1) Definition of Contrast Ratio

CR=ON (White) Luminance/OFF (Black) Luminance

\*2) Definition of Luminance and Luminance uniformity

Central luminance: The white luminance is measured at the center position “5” on the screen, see Fig.1 below.

5P Luminance (AVG): The white luminance is measured at measuring points 1,2,3,4,5.

5P Uniformity:  $\Delta L = (L_{MIN} / L_{MAX}) \times 100\%$

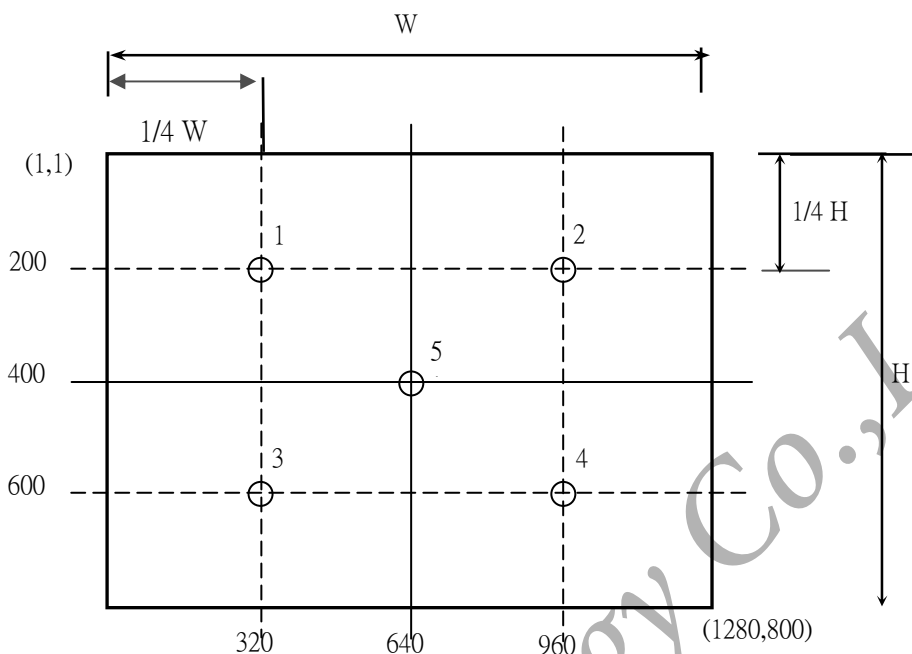

\*3) Definition of Viewing Angle( $\theta, \psi$ )

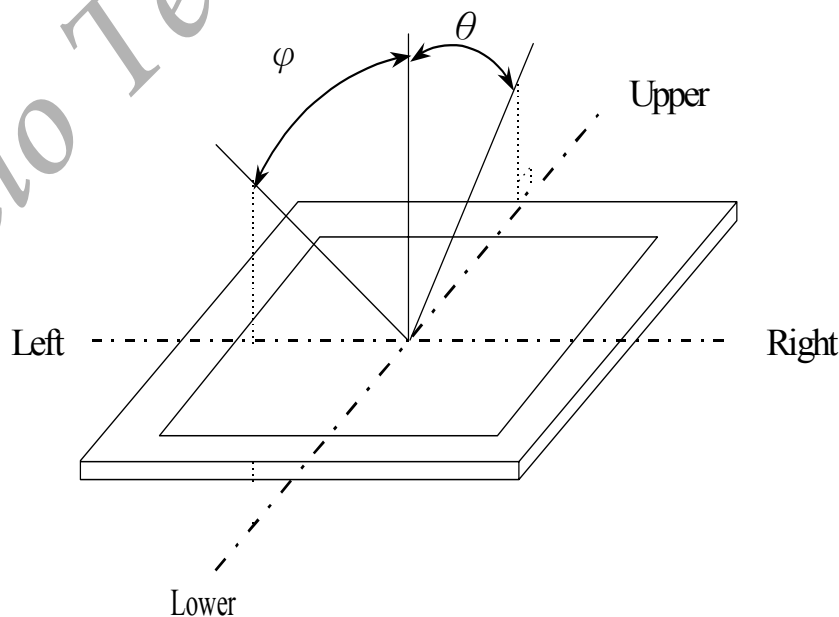



\*4) Definition of Response Time

Change the module frame to Black/white pattern and use Westar TDR-100 to measure  $t_r$  and  $t_f$  at room temperature (25°C) .

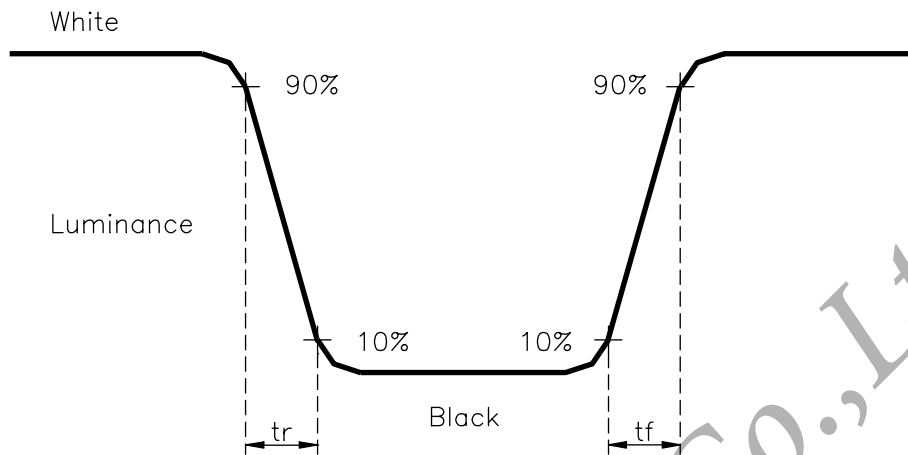

\*5) Image sticking:

Continuously display the test pattern shown in the figure below for two-hours. Then switch to full white screen. It changes from test pattern to white pattern. The previous image should not persist more than two seconds at 25°C .

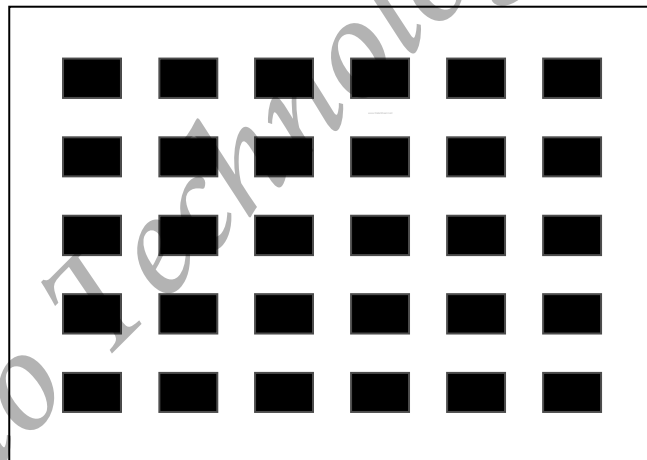

## 9.RELIABILITY TEST CONDITIONS

### (1)Temperature and Humidity

TEST ITEMS	CONDITIONS
High Temperature High Humidity Operation	50°C ; 90%RH; 240hrs (No condensation)
High Temperature High Humidity Storage	60°C ; 90%RH; 48hrs (No condensation)
High Temperature Operation	50°C ; 240hrs
High Temperature Storage	60°C ; 240hrs
Low Temperature Operation	0°C ; 240hrs
Low Temperature Storage	-20°C ; 240hrs
Thermal Shock	Between -20°C (1hr) and 60°C (1hr);100 Cycles

### (2) Shock & Vibration

ITEMS	CONDITIONS
Shock (Non-Operation)	Shock level: 2450m/s <sup>2</sup> (250G) Waveform: half sinusoidal wave, 2ms Number of shocks: one shock input in each direction of three mutually perpendicular axes for a total of six shock inputs (±X, ±Y, ±Z)
Vibration (Non-Operation)	Vibration level: 14.7m/s <sup>2</sup> (1.5G) zero to peak Waveform: sinusoidal wave Frequency range: 5 to 500 Hz Frequency sweep rate: 0.5 octave/min Duration: one sweep from 5 to 500Hz in each of three mutually perpendicular axis(each x,y,z axis: 1 hour, total 3 hours)

### (3)ESD test

Test Item	Test statements
Connector	200 pF , 0 Ω , ±250 V By using contact-mode to discharge each pin one time and then check the module frame.
module	150pF , 330Ω , ±15KV 1. Under test conditions, by using air-mode to discharge each test point 25 times continuously and then check the module frame. 2. Under test conditions, by using contact-mode to discharge each test point of panel frame 25 times continuously and then check the module frame.

### (4) Judgment standard

The judgment of the above test should be made as follow:

Pass: Normal display image with no obvious non-uniformity and no line defect.

Partial transformation of the module parts should be ignored.

Fail: No display image, obvious non-uniformity, or line defects.

## 10. HANDLING PRECAUTIONS FOR TFT-LCD MODULE

Please pay attention to the followings in handling- TFT-LCD products;

### 10.1 ASSEMBLY PRECAUTION

- (1) Please use the mounting hole on the module side in installing and do not beading or wrenching LCD in assembling. And please do not drop, bend or twist LCD module in handling.
- (2) Please design display housing in accordance with the following guidelines.
  - Housing case must be destined carefully so as not to put stresses on LCD all sides and not to wrench module. The stresses may cause non-uniformity even if there is no non-uniformity statically.
  - Keep sufficient clearance between LCD module back surface and housing when the LCD module is mounted. Approximately 1.0 mm of the clearance in the design is recommended taking into account the tolerance of LCD module thickness and mounting structure height on the housing.
  - When some parts, such as, FPC cable and ferrite plate, are installed underneath the LCD module, still sufficient clearance is required, such as 0.5mm. This clearance is, especially, to be reconsidered when the additional parts are implemented for EMI countermeasure.
  - Design the inverter location and connector position carefully so as not to give stress to lamp cable, or not to interface the LCD module by the lamp cable.
  - Keep sufficient clearance between LCD module and the others parts, such as inverter and speaker so as not to interface the LCD module. Approximately 1.0mm of the clearance in the design is recommended.
- (3) Please do not push or scratch LCD panel surface with any-thing hard. And do not soil LCD panel surface by touching with bare hands. (Polarizer film, surface of LCD panel is easy to be flawed.)
- (4) Please do not press any parts on the rear side such as source TCP, gate TCP, control circuit board and FPCs during handling LCD module. If pressing rear part is unavoidable, handle the LCD module with care not to damage them.
- (5) Please wipe out LCD panel surface with absorbent cotton or soft clothe in case of it being soiled.
- (6) Please wipe out drops of adhesives like saliva and water on LCD panel surface immediately. They might damage to cause panel surface variation and color change.
- (7) Please do not take a LCD module to pieces and reconstruct it. Resolving and reconstructing modules may cause them not to work well.
- (8) Please do not touch metal frames with bare hands and soiled gloves. A color change of the metal frames can happen during a long preservation of soiled LCD modules.
- (9) Please pay attention to handling lead wire of backlight so that it is not tugged in connecting with inverter.

### 10.2 OPERATING PRECAUTIONS

- (1) Please be sure to turn off the power supply before connecting and disconnecting signal input cable.
- (2) Please do not change variable resistance settings in LCD module. They are adjusted to the most suitable value. If they are changed, it might happen LCD does not satisfy the characteristics specification.
- (3) Please consider that LCD backlight takes longer time to become stable of radiation characteristics in low temperature than in room temperature.
- (4) A condensation might happen on the surface and inside of LCD module in case of sudden change of ambient temperature.
- (5) Please pay attention to displaying the same pattern for very long time. Image might stick on LCD. If then, time going on can make LCD work well.
- (6) Please obey the same caution descriptions as ones that need to pay attention to ordinary electronic parts.

### 10.3 PRECAUTIONS WITH ELECTROSTATICS

- (1) This LCD module use CMOS-IC on circuit board and TFT-LCD panel, and so it is easy to be affected by electrostatics. Please be careful with electrostatics by the way of your body connecting to the ground and so on.
- (2) Please remove protection film very slowly on the surface of LCD module to prevent from electrostatics occurrence.

#### 10.4 STORAGE PRECAUTIONS

- (1) When you store LCDs for a long time, it is recommended to keep the temperature between 0°C ~40°C without the exposure of sunlight and to keep the humidity less than 90%RH.
- (2) Please do not leave the LCDs in the environment of high humidity and high temperature such as 60°C 90%RH.
- (3) Please do not leave the LCDs in the environment of low temperature; below -20°C.

#### 10.5 SAFETY PRECAUTIONS

- (1) When you waste LCDs, it is recommended to crush damaged or unnecessary LCDs into pieces and wash them off with solvents such as acetone and ethanol, which should later be burned.
- (2) If any liquid leaks out of a damaged-glass cell and comes in contact with the hands, wash off thoroughly with soap and water.

#### 10.6 OTHERS

- (1) A strong incident light into LCD panel might cause display characteristics' changing inferior because of polarizer film, color filter, and other materials becoming inferior. Please do not expose LCD module direct sunlight and strong UV rays.
- (2) Please pay attention to a panel side of LCD module not to contact with other materials in preserving it alone.
- (3) For the packaging box, please pay attention to the followings:
  - Packaging box and inner case for LCD are designed to protect the LCDs from the damage or scratching during transportation. Please do not open except picking LCDs up from the box.
  - Please do not pile them up more than 3 boxes. (They are not designed so.) And please do not turn over.
  - Please handle packaging box with care not to give them sudden shock and vibrations. And also please do not throw them up.
  - Packing box and inner case for LCDs are made of cardboard. So please pay attention not to get them wet. (Such like keeping them in high humidity or wet place can occur getting them wet.)