



Chunghwa Picture Tubes, Ltd.

Technical Specification

To : **SCL**
Date : **2011/11/17**

CPT TFT-LCD
CLAA156WA12

ACCEPTED BY :

APPROVED BY	CHECKED BY	PREPARED BY
Ronald Huang	Alan Shih	Carol Shen

Prepared by : TFT-LCD Product Planning Management Division

CHUNGHWA PICTUER TUBES, LTD.

1127 Hopin Rd., Padeh, Taoyuan, Taiwan 334, R.O.C.

TEL: +886-3-3675151 FAX: +886-3-377-3003

Doc. No:	CLAA156WA12-SCL-V1-20111117	Issue Date:	2011/11/17
----------	-----------------------------	-------------	------------

Modification Record List

Revision No.	Date	Modification Index
V1	2011/11/17	

Table Of Content

1. VERVIEW.....	3
2. ABSOLUTE MAXIMUN RATINGS.....	4
3. ELECTRICAL CHARACTERISTICS.....	5
4. CONNECTER INTERFACE PIN & DUNCTION.....	10
5. INTERFACE TIMING CHART.....	12
6. BLOCK UAGRAM.....	15
7. MECHANICAL DIMENSION.....	16
8. OPTICAL CHARACTERISTICS.....	18
9. RELIABILITY TEST CONDITIONS.....	22
10. HANDLING PRECAUTIONS FOR TFT-LCD MODULE.....	23

1. OVERVIEW

CLAA156WA12 is 15.6" color (16 : 9) TFT-LCD (Thin Film Transistor Liquid Crystal Display) module composed of LCD panel, LVDS driver ICs, control circuit and backlight. By applying 6 bit digital data, 1366xRGB (3) x768, 262K-color images are displayed on the 15.6" diagonal screen. general specifications are summarized in the following table :

ITEM	SPECIFICATION
Display Area	344.232 (H)x193.536 (V)(mm) (15.6-inch diagonal)
Number of Pixels	1366 x3(H)x768 (V)
Pixel Pitch	0.252 (H)x0.252(V) (mm)
Color Pixel Arrangement	RGB vertical stripe
Display Mode	Normally white
Number of Colors	262,144(6bits)(LVDS)
Gamut	56%(Min)/60%(Typ)
Optimum Viewing Angle	6 o'clock
Response Time	8ms (Typ)
Surface Treatment	Anti Glare
Viewing Angle	40°、40°/15°、30°(Min.)
Brightness	220 cd/m ² (5point)/20 mA (Typ.) 200 cd/m ² (5point)/20 mA (Min.)
Uniformity	5point : 80%, 13point : 65%
Consumption of Power	5.8W (Max)
Module Size	359.8(W)x210(H)x5.5(D) (mm) (Max)
Module Weight	450g (Max)

The LCD Products listed on this document are not suitable for use of aerospace equipment, submarine cable, and nuclear reactor control system and life support systems. If customers intend to use these LCD products for applications listed above or those not included in the "Standard" list as follows, please contact our sales in advance.

Standard : Computer, Office equipment, Communication equipment, Test and Measurement equipment, Machine tool, Industrial robot, Audio and Visual equipment, Other consumer products.

2. ABSOLUTE MAXIMUM RATINGS

The following are maximum value, which if exceeded, may cause faulty operation or damage to the unit.

ITEM	SYMBOL	MIN.	MAX.	UNIT	NOTE
LCD Power Voltage	VCC	0	4.0	V	
LED Driver Input Voltage	VBL+	0	21	V	
Operation Temperature	Top	0	50	°C	*1).*2).*3).*4)
Storage Temperature	Tstg	-25	65	°C	*1).*2).*3)

【Note】

- *1) The relative temperature and humidity range are as below sketch, 90%RH Max. ($T_a \leq 40^\circ\text{C}$)
- *2) The maximum wet bulb temperature $\leq 39^\circ\text{C}$ ($T_a > 40^\circ\text{C}$) and without dewing.
- *3) If product in environment which over the definition of the relative temperature and humidity out of range too long, it will affect visual of LCD.
- *4) If you operate LCD in normal temperature range, the center surface of panel should be under 50°C .

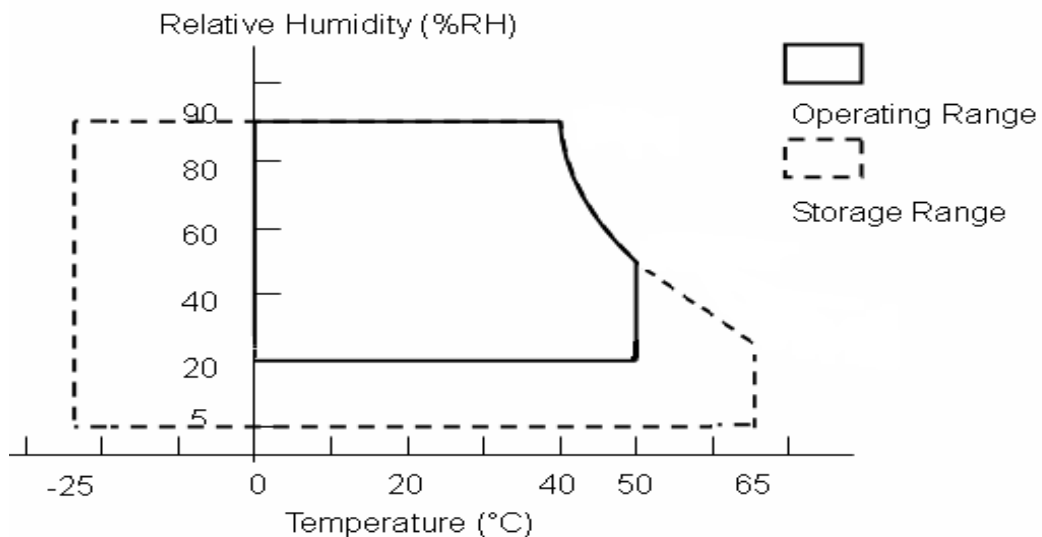

3. ELECTRICAL CHARACTERISTICS

(A) TFT LCD

TEM	SYMBOL	MIN	TYP	MAX	UNIT	REMARK
LCD POWER VOLTAGE	VCC	3.0	3.3	3.6	V	[Note 1]
LCD POWER CURRENT	ICC	-	350	400	mA	[Note 2]
Rush CRRENT	Irush	-	-	2	A	[Note 3]

DisplayPort Signal Definite :

The VESA DisplayPort related AC specification is compliant with the specification in the VESA DisplayPort Standard v1.1a

[Note 1] Power Sequence :

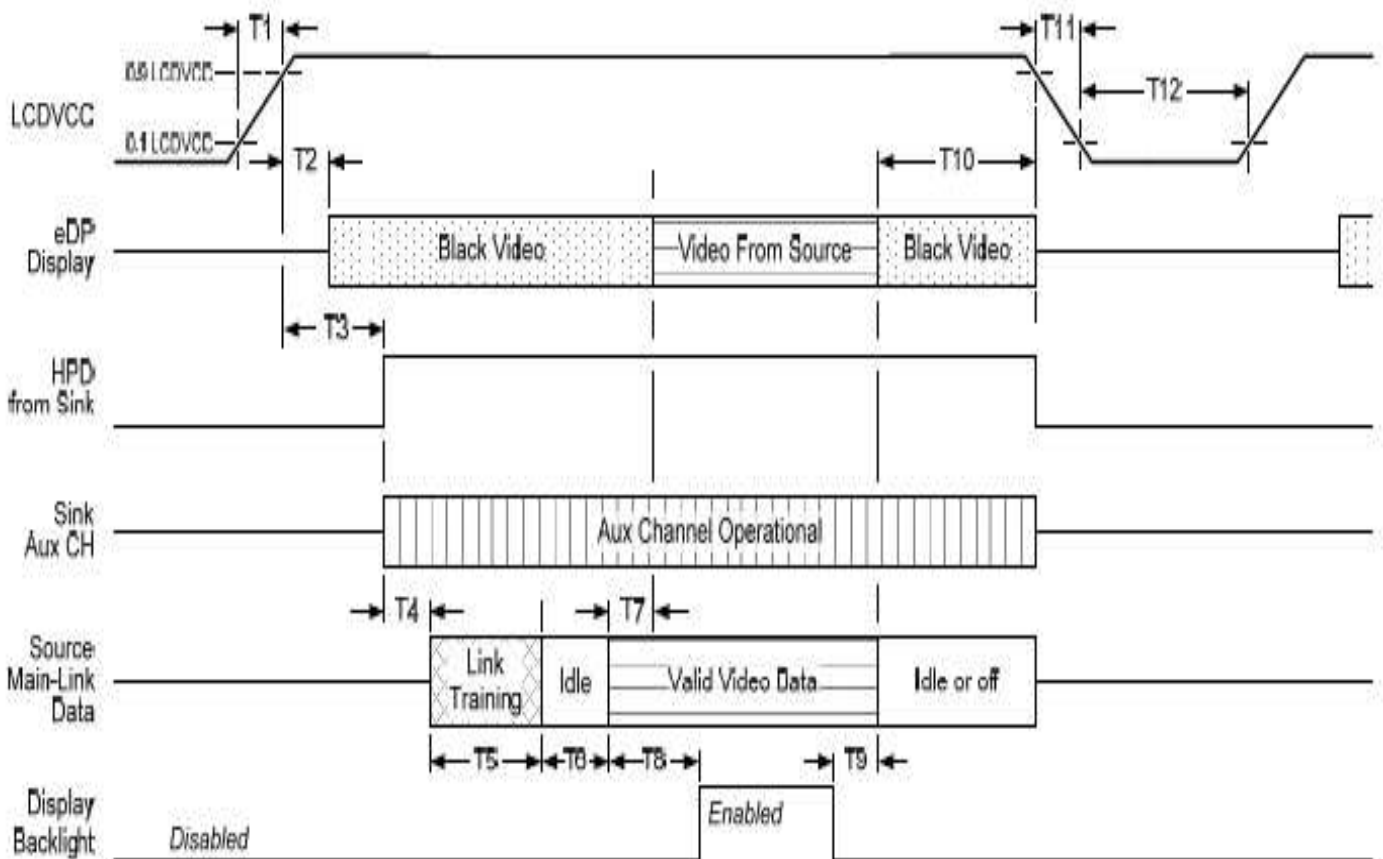

Timing Parameter	Description	Reqd. By	Limits		Notes
			Min	Max	
T1	Power rail rise time, 10% to 90%	Source	0.5ms	10ms	
T2	Delay from LCDVCC to black video generation	Sink	0ms	200ms	Prevents display noise until valid video data is received from the Source (see note 1 below)
T3	Delay from LCDVCC to HPD high	Sink	0ms	200ms	Sink Aux Channel must be operational upon HPD high
T4	Delay from HPD high to link training initialization	Source	-	-	Allows for Source to read Link capability and initialize
T5	Link training duration	Source	-	-	Dependant on Source link training protocol
T6	Link idle	Source	-	-	Min accounts for required BS-Idle pattern. Max allows for Source frame synchronization.
T7	Delay from valid video data from Source to video on display	Sink	0ms	50ms	Max allows Sink validate video data and timing
T8	Delay from valid video data from Source to backlight enable	Source	-	-	Source must assure display video is stable
T9	Delay from backlight disable to end of valid video data	Source	-	-	Source must assure backlight is no longer illuminated (see note 1 below)
T10	Delay from end of valid video data from Source to power off	Source	0ms	500ms	
T11	Power rail fall time, 90% to 10%	Source	-	10ms	
T12	Power off time	Source	500ms	-	

VCC-dip state

(1) when $3.0 > VCC \geq 2.7V$ & $t_d \leq 10$ ms module works well.

(2) when $VCC < 2.7V$, VCC-dip condition should be the same as the VCC-turn-off condition.

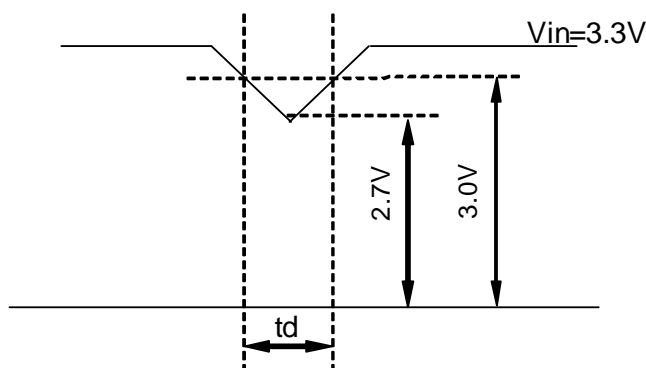

[Note 2] Typical value is Mosaic (32*36 Checker board) Pattern : 768 line mode ◦

Circuit condition (Typ.) :

VCC=3.3 V , fV=60 Hz fH=48.36 kHz , fCLK=75.44 MHz

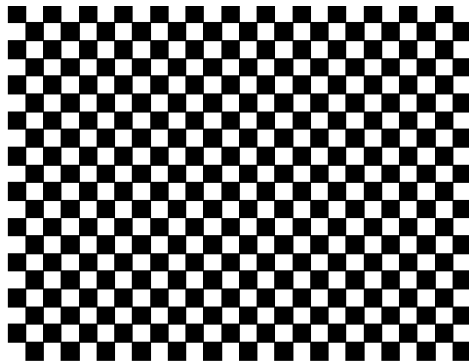

Max value is Black Pattern : 768 line mode ◦

Circuit condition (Max.) : VCC=3.3 V , fV=60 Hz fH=48.36 kHz , fCLK=75.44 MHz

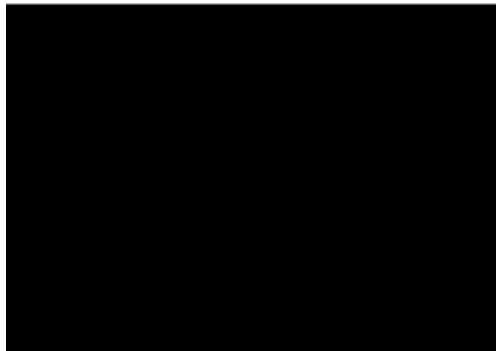

[Note 3] Irush measure condition

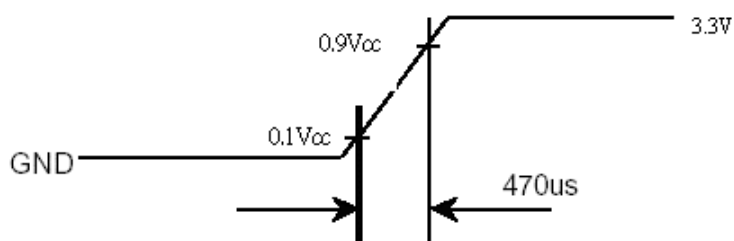
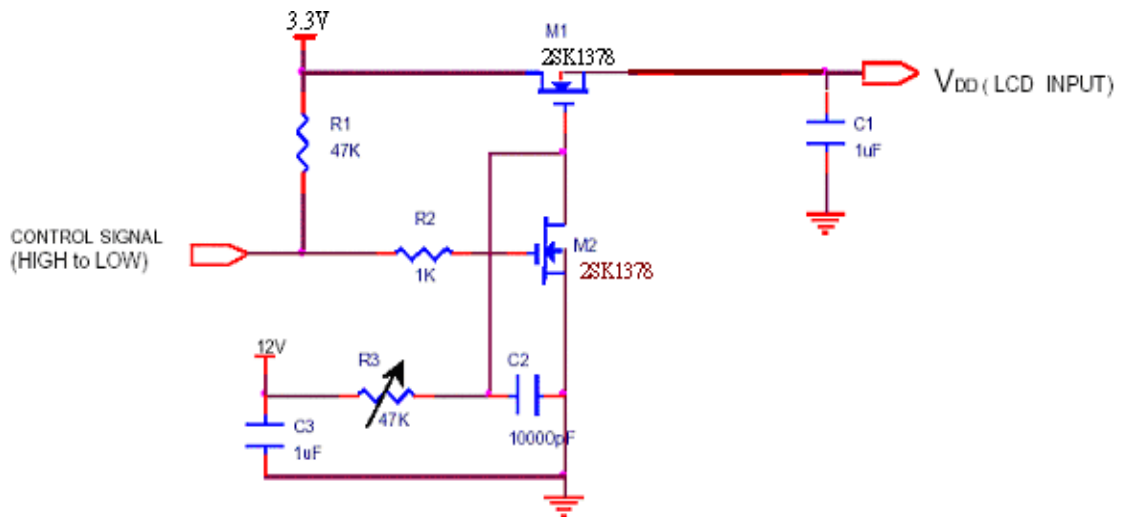

(B) BACK LIGHT

(a.) ELECTRICAL CHARACTERISTICS

Ta=25°C

ITEM	SYMBOL	MIN	TYP	MAX	UNIT	NOTE
LED Driver Input Voltage	VBL+	7	12	21	V	
LED Driver Input Current	IBL+	-	-	650	mA	*1)
Forward Voltage	VF	3.0	3.2	3.5	V	*2) I _F =20mA
Forward Current	IF	18	20	22	mA	*2) I _F =20mA
Power consumption	PLED	-	4	4.55	W	*2)*3) I _F =20mA
PWM Frequency	PWM_BL	180	200	220	Hz	
Duty ratio	Dim	10	-	100	%	

(b.) LED LIFE – TIME

ITEM	Condition	min	typ	max	UNIT	NOTE
LIFE TIME	I _F =20mA、Ta=25°C	15000	-	-	hrs	*4)

(c.) LED ON/OFF Sequence :

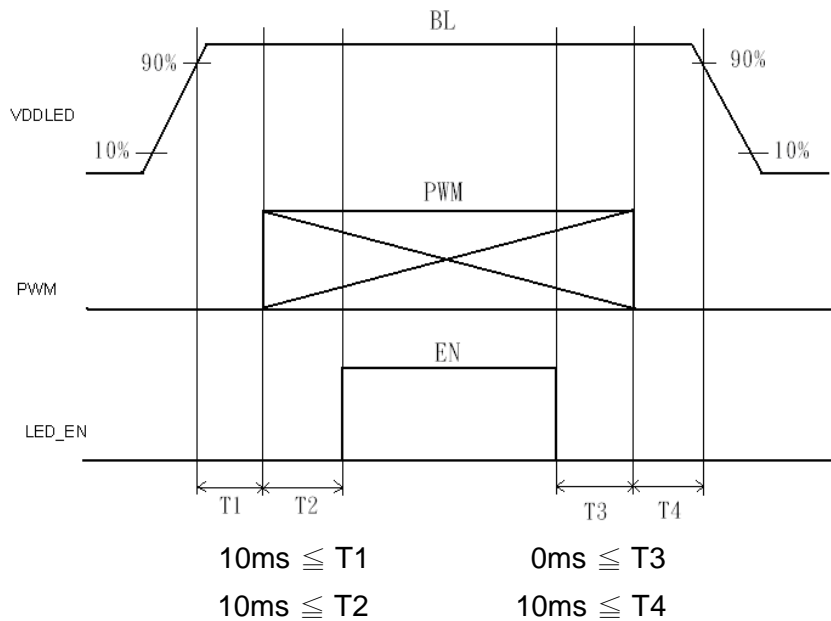

Note : The duty of LED dimming signal should be more than 20% in T2 and T3

【Note】

- *1) Maximum LED Driver Input Current at 7V Input Voltage/PWM Duty 100%.
- *2) Measure method : a. LED current is measured by utilizing a current meter as show below.
b. System power PLED is measured at input voltage 12V.

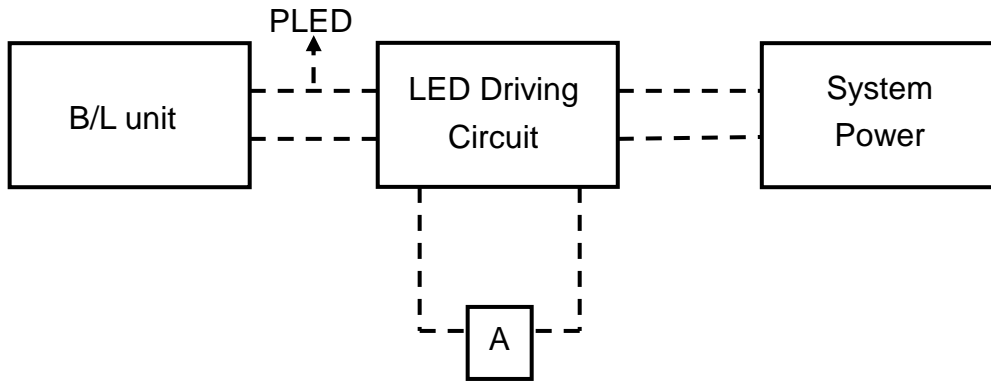

- *3) Calculator value for reference $I_F \times V_F \times N = P_{LED}$
- *4) Life time means that estimated time to 50% degradation of initial luminous intensity.

4. Connector Interface PIN & Function

(a) CN1 (Interface signal)

Outlet connector: 20455-030E-12 (I-PEX)

Pin No.	SYMBOL	FUNCTION
1	NC	Reserved
2	H_GND	High Speed Ground
3	NC	Reserved
4	NC	Reserved
5	H_GND	High Speed Ground
6	LAN0_N	Complement Signal Link Lane 0
7	LAN0_P	True Signal Link Lane 1
8	H_GND	High Speed Ground
9	AUX_P	True Signal Auxiliary Ch.
10	AUX_N	Complement Signal Auxiliary Ch.
11	H_GND	High Speed Ground
12	LCD_VCC	LCD logic and driver power
13	LCD_VCC	LCD logic and driver power
14	NC	Reserved
15	LCD_GND	LCD logic and driver ground
16	LCD_GND	LCD logic and driver ground
17	NC or HPD	HPD signal pin (Optional in sink device)
18	BL_GND	Backlight ground
19	BL_GND	Backlight ground
20	BL_GND	Backlight ground
21	BL_GND	Backlight ground
22	BL_ENABLE	Backlight On/Off
23	BL_PWM_DIM	System PWM signal input for dimming
24	SMBUS_CLK	Backlight Control Clk
25	SMBUS_DATA	Backlight Control Data
26	BL_PWR	Backlight power 7V-21V
27	BL_PWR	Backlight power 7V-21V
28	BL_PWR	Backlight power 7V-21V
29	BL_PWR	Backlight power 7V-21V
30	NC	Reserved

5. INTERFACE TIMING CHART

(a). DisplayPort input time sequence

Horizontal sequence

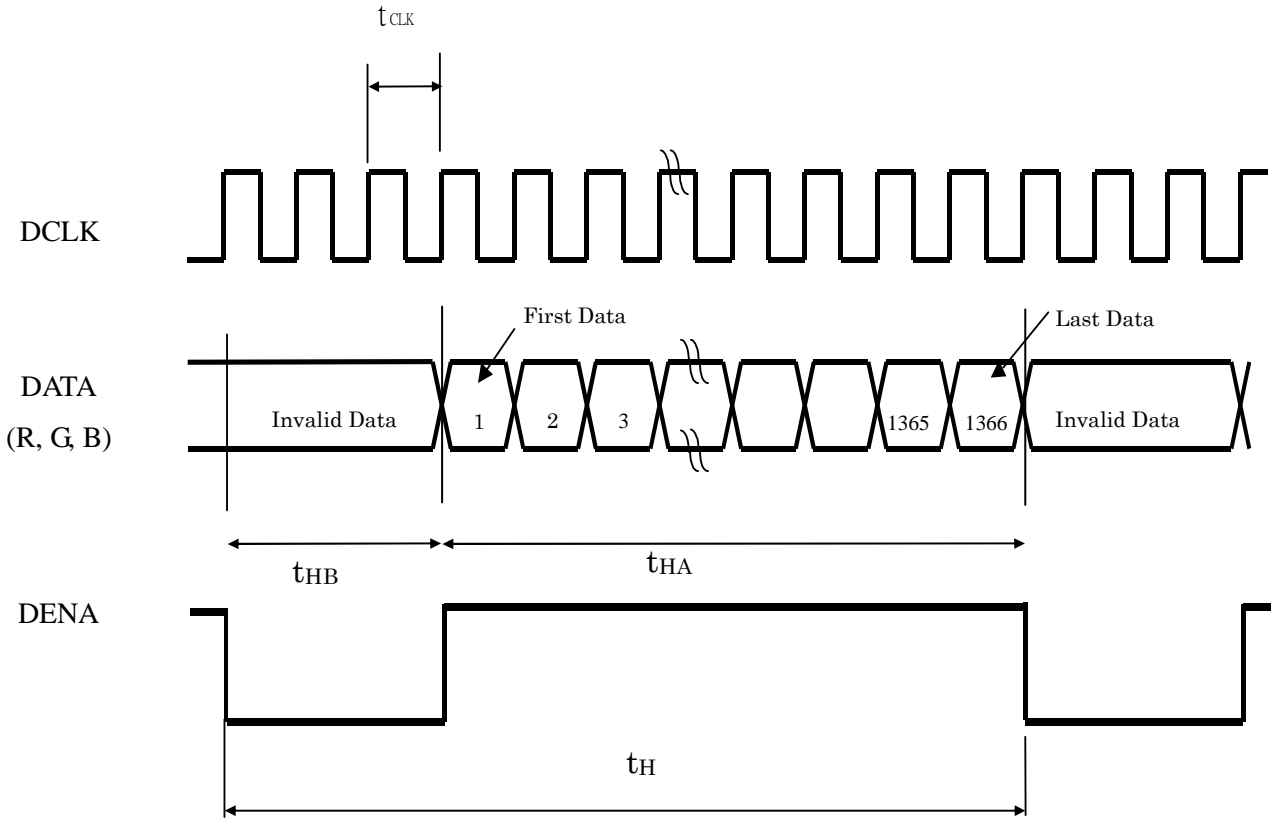

(b) LCD input time sequence

Vertical sequence

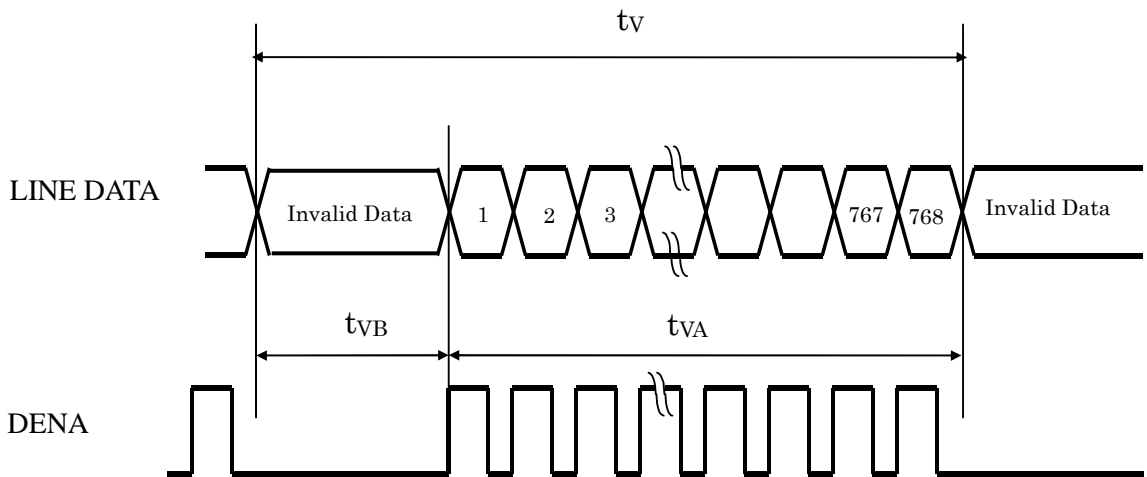

(2) Timing Chart

ITEM			SYMBOL	MIN	TYP	MAX	UNIT	
LCD Timing	Frame Rate		-	60			Hz	
	DCLK		Frequency	f_{CLK}	65.83	75.44	88.74	MHz
			Period	t_{CLK}	11.26	13.25	15.19	ns
	DENA	Horizontal	Horizontal total time	t_H	1414	1560	1700	t_{CLK}
			Horizontal Active time	t_{HA}	1366	1366	1366	t_{CLK}
			Horizontal Blank time	t_{HB}	48	194	334	t_{CLK}
		Vertical	Vertical total time	t_V	776	806	870	t_H
			Vertical Active time	t_{VA}	768	768	768	t_H
			Vertical Blank time	t_{VB}	8	38	102	t_H

(3) DATA mapping

Color	Input Data	R DATA						G DATA						B DATA					
		R5	R4	R3	R2	R1	R0	G5	G4	G3	G2	G1	G0	B5	B4	B3	B2	B1	B0
		MS B					LS B	MS B					LS B	MS B					LS B
Basic Color	Black	0	0	0	0	0	0	0	0	0	0	0	0	0	0	0	0	0	0
	Red(63)	1	1	1	1	1	1	0	0	0	0	0	0	0	0	0	0	0	0
	Green(63)	0	0	0	0	0	0	1	1	1	1	1	1	0	0	0	0	0	0
	Blue(63)	0	0	0	0	0	0	0	0	0	0	0	0	1	1	1	1	1	1
	Cyan	0	0	0	0	0	0	1	1	1	1	1	1	1	1	1	1	1	1
	Magenta	1	1	1	1	1	1	0	0	0	0	0	0	1	1	1	1	1	1
	Yellow	1	1	1	1	1	1	1	1	1	1	1	1	0	0	0	0	0	0
	White	1	1	1	1	1	1	1	1	1	1	1	1	1	1	1	1	1	1
RED	RED(0)	0	0	0	0	0	0	0	0	0	0	0	0	0	0	0	0	0	0
	RED(1)	0	0	0	0	0	1	0	0	0	0	0	0	0	0	0	0	0	0
	RED(2)	0	0	0	0	1	0	0	0	0	0	0	0	0	0	0	0	0	0
	RED(62)	1	1	1	1	1	0	0	0	0	0	0	0	0	0	0	0	0	0
	RED(63)	1	1	1	1	1	1	0	0	0	0	0	0	0	0	0	0	0	0
	Green	Green(0)	0	0	0	0	0	0	0	0	0	0	0	0	0	0	0	0	0
Green(1)		0	0	0	0	0	0	0	0	0	0	0	1	0	0	0	0	0	0
Green(2)		0	0	0	0	0	0	0	0	0	0	1	0	0	0	0	0	0	0
Green(62)		0	0	0	0	0	0	1	1	1	1	1	0	0	0	0	0	0	0
Green(63)		0	0	0	0	0	0	1	1	1	1	1	1	0	0	0	0	0	0
Blue		Blue(0)	0	0	0	0	0	0	0	0	0	0	0	0	0	0	0	0	0
	Blue(1)	0	0	0	0	0	0	0	0	0	0	0	0	0	0	0	0	0	1
	Blue(2)	0	0	0	0	0	0	0	0	0	0	0	0	0	0	0	0	1	0
	Blue(62)	0	0	0	0	0	0	0	0	0	0	0	0	1	1	1	1	1	0
	Blue(63)	0	0	0	0	0	0	0	0	0	0	0	0	1	1	1	1	1	1

【Note】

1) Gray level:

Color(n) : n is level order; higher n means brighter level.

2) DATA:

1: high , 0: low

6. BLOCK DIAGRAM

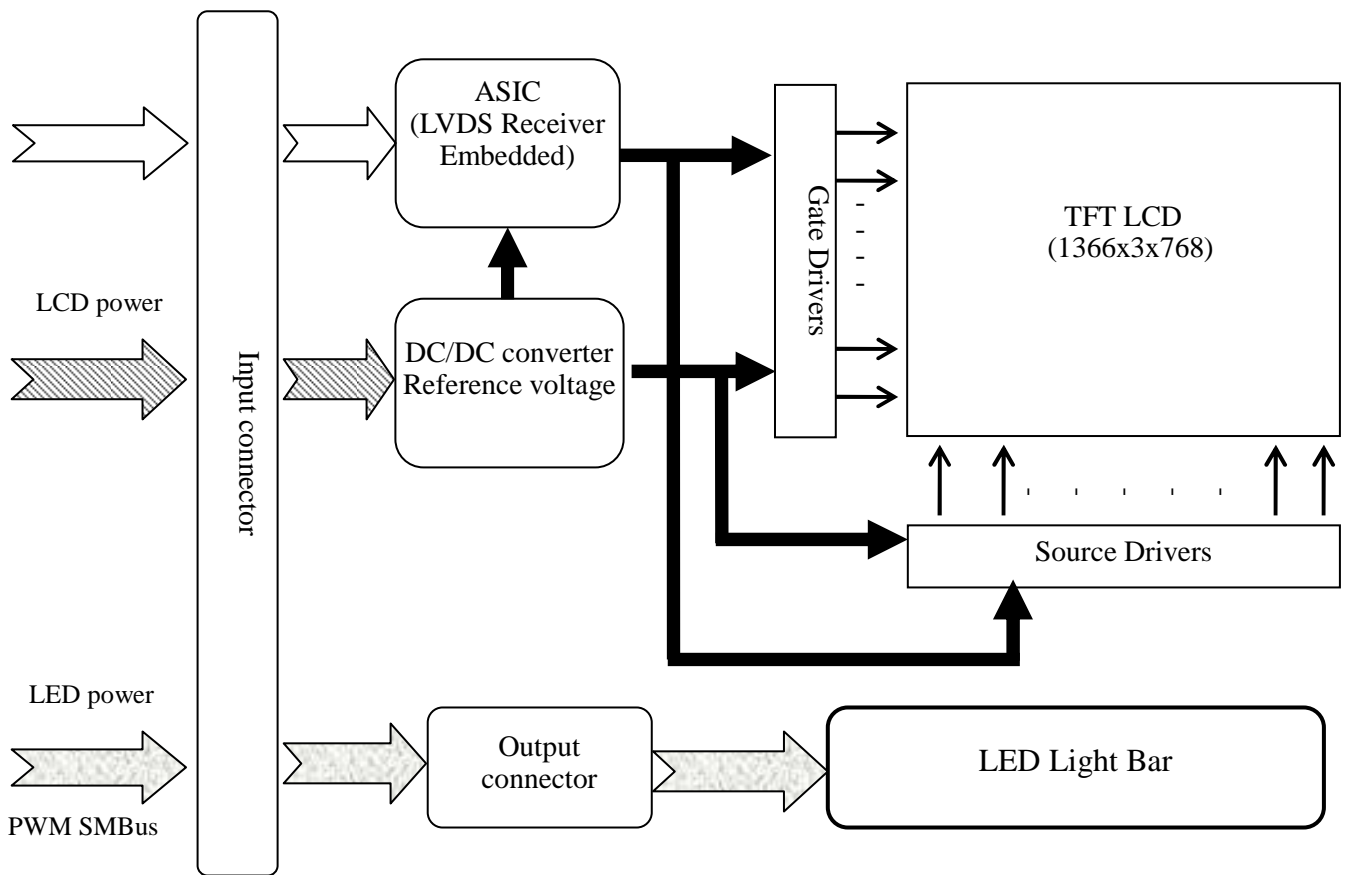

7. MECHANICAL SPECIFICATION

(1) Front side

The tolerance, not show in the figure, is $\pm 0.5\text{mm}$.

[Unit : mm]

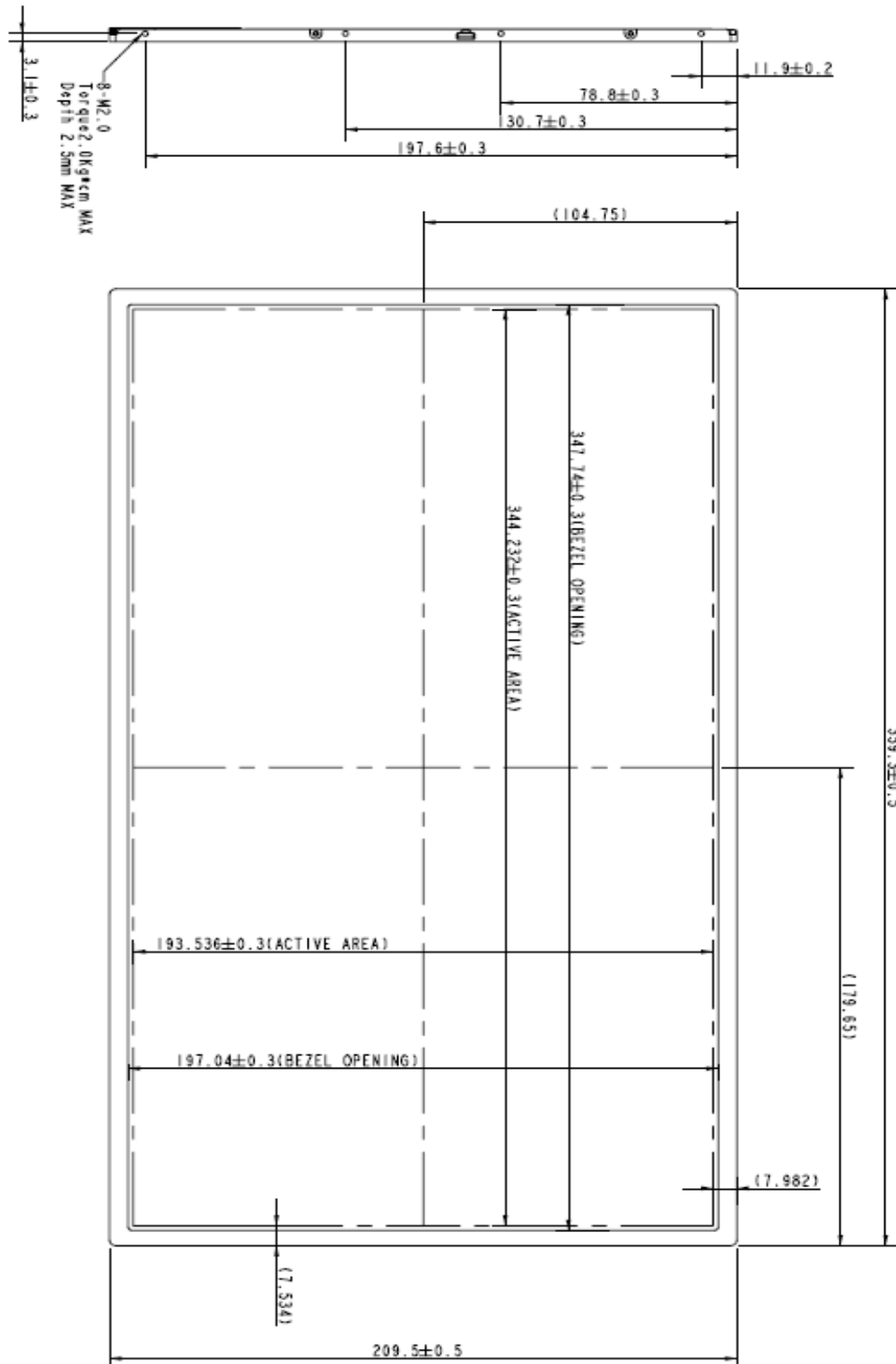

2) Rear side

The tolerance, not show in the figure, is $\pm 0.5\text{mm}$.

[Unit : mm]

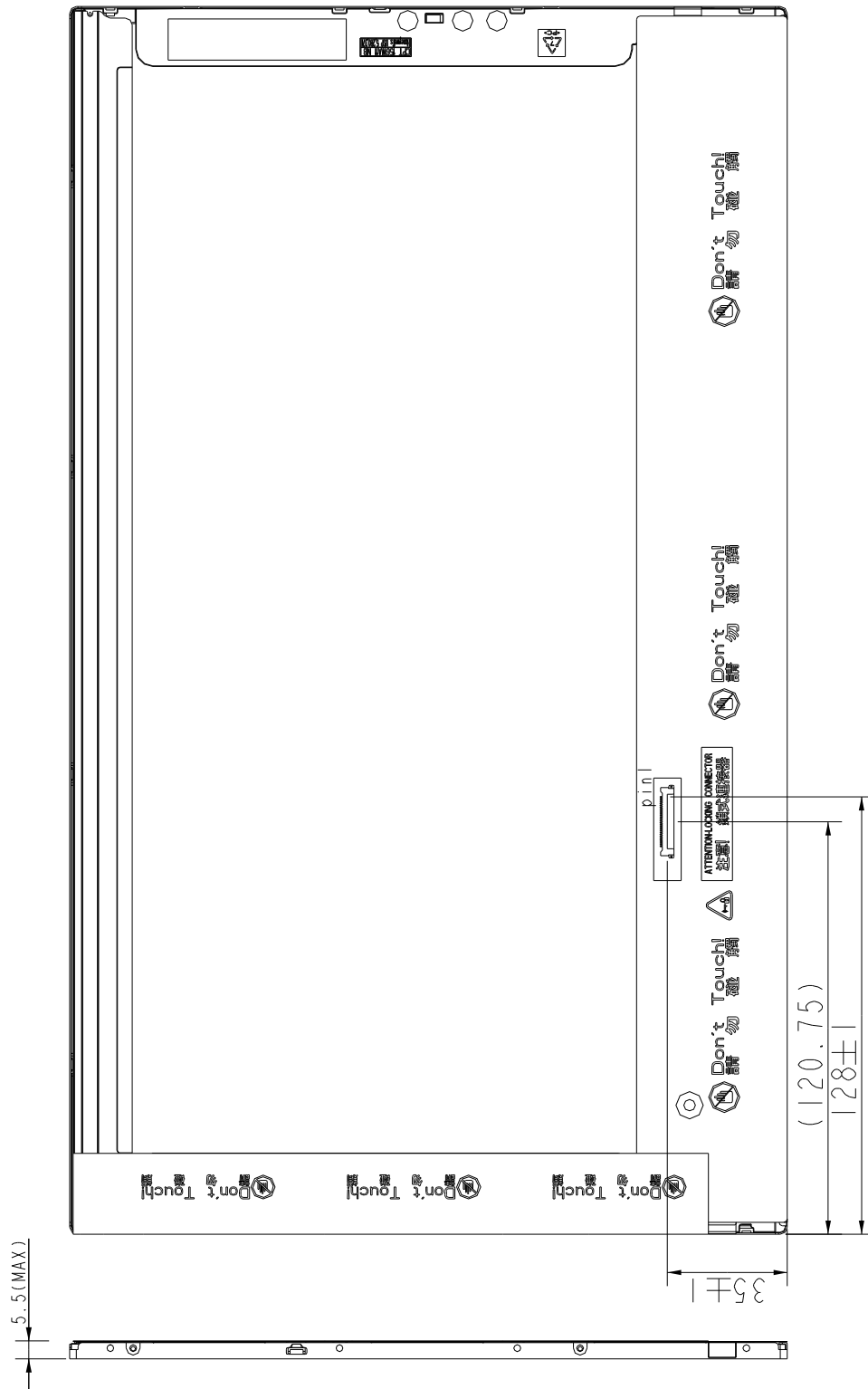

8. OPTICAL CHARACTERISTICS

Ta=25°C , VDD=3.3V

ITEM		SYMBOL	CONDITION	MIN	TYP	MAX	UNIT	NOTE
Contrast Ratio		CR	$\theta = \psi = 0^\circ$	400	500	-	--	*1) 2)
Luminance (5P)		L	$\theta = \psi = 0^\circ$	200	220	-	cd/m ²	*1) 3)
Uniformity(5P)		ΔL	$\theta = \psi = 0^\circ$	80	-	-	%	*1) 3)
Response Time		Tr	$\theta = \psi = 0^\circ$	-	3	6	ms	*5)
		Tf	$\theta = \psi = 0^\circ$	-	5	10	ms	*5)
Cross talk		CT	$\theta = \phi = 0^\circ$ ^{*3}	-	-	1	%	*6)
View angle	Horizontal	Ψ	$CR \geq 10$	40/-40	45/-45	-	°	*4)
	Vertical	θ		15/-30	20/-35	-	°	*4)
Color Temperature Coordinate	W	X	$\theta = \psi = 0^\circ$	0.283	0.313	0.343	--	*3)
		Y		0.299	0.329	0.359		
	R	X		0.590	0.620	0.650	--	
		Y		0.310	0.340	0.370		
	G	X		0.300	0.330	0.360	--	
		Y		0.540	0.570	0.600		
B	X	0.120	0.150	0.180	--			
	Y	0.030	0.060	0.090				
Gamut			$\theta = \psi = 0^\circ$	56%	60%	-	--	--
Gamma		γ	GL	2.0	2.2	2.4	--	*7)

Color coordinate and color gamut are measured by SRUL1R, response time is measured by TRD-100, and all the other items are measured by BM-5A (TOPCON). All these items are measured under the dark room condition (no ambient light).

Measurement Condition: IL=20mA(each LED)

Definition of these measurement items is as follows:

*1) Setup of Measurement Equipment

The LCD module should be turn-on to a stable luminance level to be reached. The measurement should be

executed after lighting Backlight for 20 minutes and in a dark room.

***2) Definition of Contrast Ratio**

CR=ON (White) Luminance/OFF (Black) Luminance

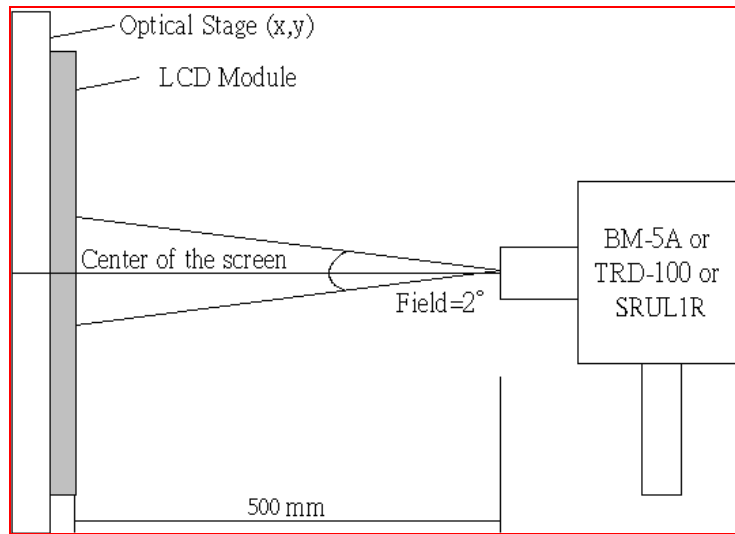

***3) Definition of Luminance and Luminance uniformity**

Central luminance: The white luminance is measured at the center position "5" on the screen, see Fig.1 below.

5P Luminance (AVG): The white luminance is measured at measuring points 1、2、3、4、5, see Fig.1 below.

5P Uniformity: $\Delta L = (L_{min} / L_{max}) \times 100\%$

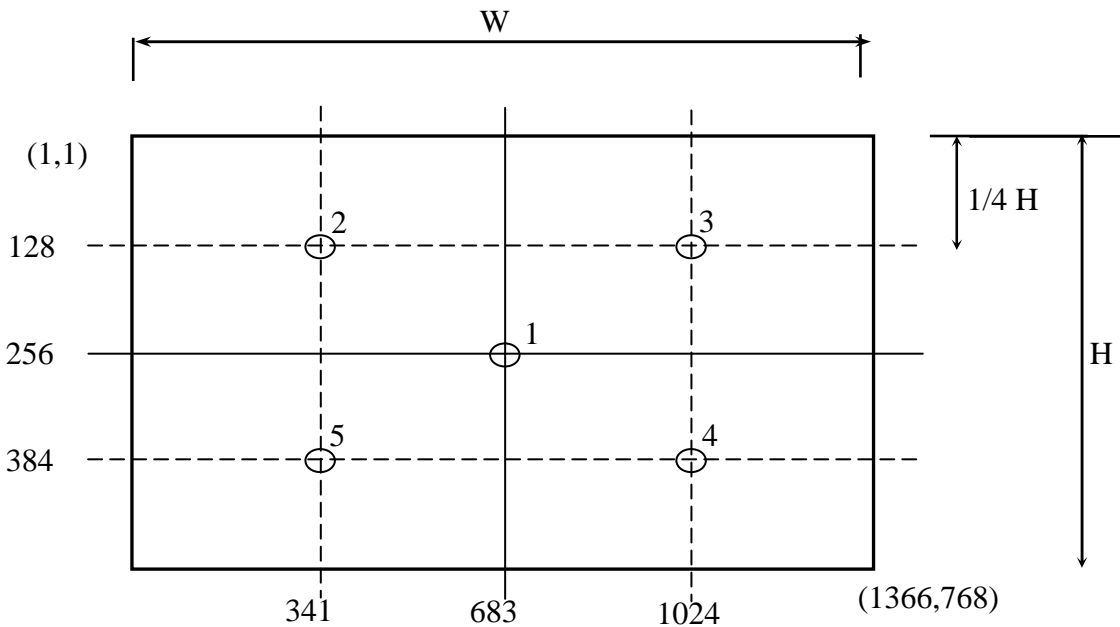

***4) Definition of view angle(θ , ψ)**

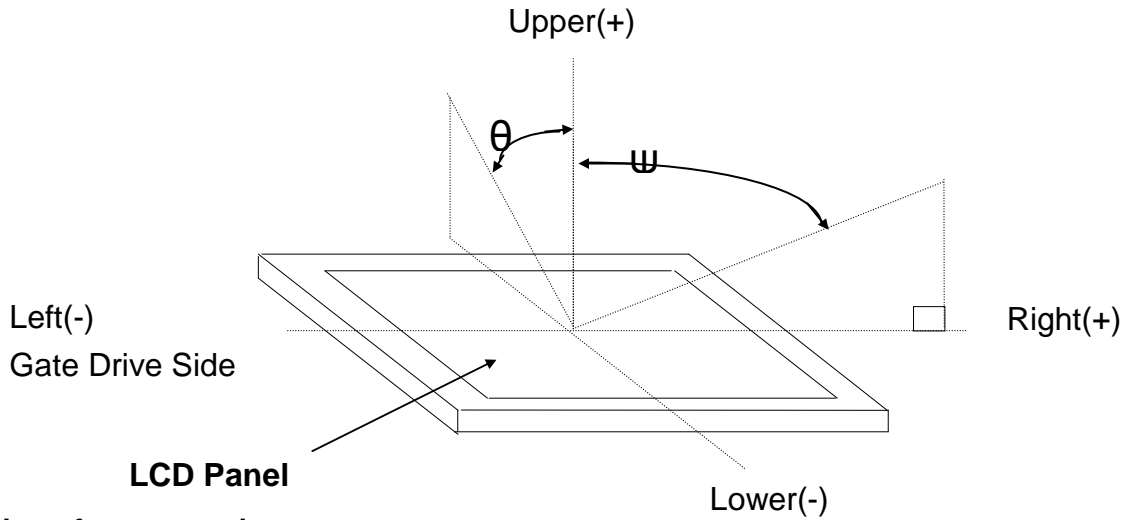

***5) Definition of response time**

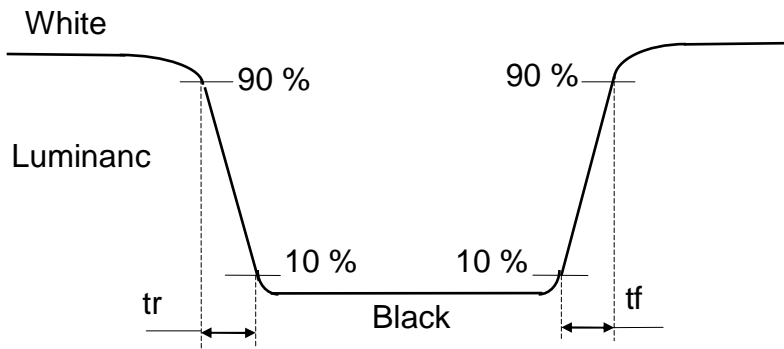

***6) Crosstalk Modulation Ratio**

$$CT = | Y_B - Y_A | / Y_{Ax} \times 100\%$$

Y_A , Y_B measure position and definition

Y_A means luminance at gray level 31(exclude gray level 0 pattern)

Y_B means luminance at gray level 31(include gray level 0 pattern)

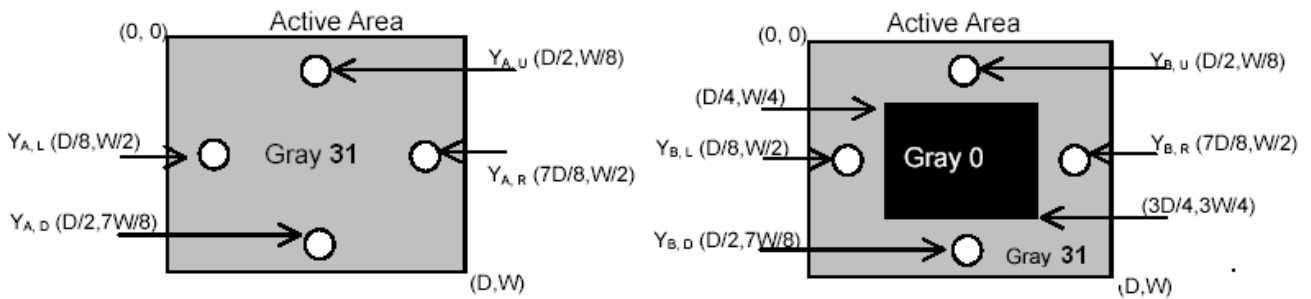

***7) Definition of Gamma (VESA)**

Based on Customer Sample, take the average value as a standard center value and the variation range of gamma value caused by loop voltage error should be between +/- 0.2. the bellow figure shows how to obtain the gamma curve and γ (from gray level: 0、4、8-----60、63).

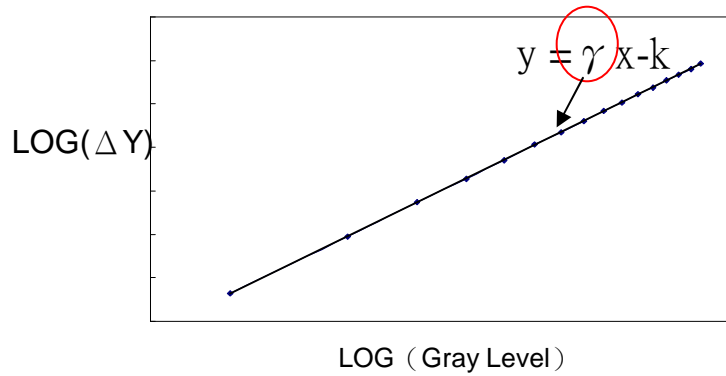

9. RELIABILITY TEST CONDITIONS

(1) Temperature and Humidity

TEST ITEMS	CONDITIONS
High Temperature Operation	50° C ; 250Hrs
High Temperature Storage	65° C ; 250Hrs
High Temperature High Humidity Operation	40° C ; 95%RH ; 250Hrs
High Temperature High Humidity Storage	60° C ; 90%RH ; 48 Hrs
Low Temperature Operation	0° C ; 250 Hrs
Low Temperature Storage	-30° C ; 250 Hrs
Thermal Shock	-40° C (0.5 Hr) ~ 65° C (0.5 Hr) , Ramp < 20° C , 100 Cycles
Temperature and pressure Storage	-0° C ; 24 Hrs ; 260hPa

(3) ESD

	Surface discharge(Panel display area · Frame · PWB · Panel back side)		Electrics capacity of Connector
	Contact	Air	Contact
Capacity	150 pF	150 pF	200 pF
Resistance	330 Ω	330 Ω	0 Ω
Voltage	±8kV	±8kV/±15kV	±250 V
Interval	1 sec	1 sec	1 sec
Times(single point)	25	25	1

(4) MTBF without B/L: 200,000 Hrs (min) lifetimes.

(5) Judgment standard

The judgment of the above test should be made as follow:

Pass : Normal display image with no obvious non-uniformity and no line defect.

Partial transformation of the module parts should be ignored.

Fail : No display image, obvious non-uniformity, or line defects

10. HANDLING PRECAUTIONS FOR TFT-LCD MODULE

Please pay attention to the followings in handling- TFT-LCD products.

10.1 ASSEMBLY PRECAUTION

- (1) Please use the mounting hole on the module side in installing and do not beading or wrenching LCD in assembling. And please do not drop, bend or twist LCD module in handling.
- (2) Please design display housing in accordance with the following guidelines.
 - Housing case must be destined carefully so as not to put stresses on LCD all sides and not to wrench module. The stresses may cause non-uniformity even if there is no non-uniformity statically.
 - Keep sufficient clearance between LCD module back surface and housing when the LCD module is mounted. Approximately 1.0 mm of the clearance in the design is recommended taking into account the tolerance of LCD module thickness and mounting structure height on the housing.
 - When some parts, such as, FPC cable and ferrite plate, are installed underneath the LCD module, still sufficient clearance is required, such as 0.5mm. This clearance is, especially, to be reconsidered when the additional parts are implemented for EMI countermeasure.
 - Keep sufficient clearance between LCD module and the others parts, such as speaker so as not to interface the LCD module. Approximately 1.0mm of the clearance in the design is recommended.
- (3) Please do not push or scratch LCD panel surface with any-thing hard. And do not soil LCD panel surface by touching with bare hands. (Polarizer film, surface of LCD panel is easy to be flawed.)
- (4) Please do not press any parts on the rear side such as source TCP, gate TCP, control circuit board and FPCs during handling LCD module. If pressing rear part is unavoidable, handle the LCD module with care not to damage them.
- (5) Please wipe out LCD panel surface with absorbent cotton or soft clothe in case of it being soiled.
- (6) Please wipe out drops of adhesives like saliva and water on LCD panel surface immediately. They might damage to cause panel surface variation and color change.
- (7) Please do not take a LCD module to pieces and reconstruct it. Resolving and reconstructing modules may cause them not to work well.
- (8) Please do not touch metal frames with bare hands and soiled gloves. A color change of the metal frames can happen during a long preservation of soiled LCD modules.

10.2 OPERATING PRECAUTIONS

- (1) Please be sure to turn off the power supply before connecting and disconnecting signal input cable.
- (2) Please do not change variable resistance settings in LCD module. They are adjusted to the most suitable value. If they are changed, it might happen LCD does not satisfy the characteristics specification.
- (3) Please consider that LCD backlight takes longer time to become stable of radiation

characteristics in low temperature than in room temperature.

- (4) A condensation might happen on the surface and inside of LCD module in case of sudden change of ambient temperature.
- (5) Please pay attention to displaying the same pattern for very long time. Image might stick on LCD. If then, time going on can make LCD work well.
- (6) Please obey the same caution descriptions as ones that need to pay attention to ordinary electronic parts.

10.3 PRECAUTIONS WITH ELECTROSTATICS

- (1) This LCD module use CMOS-IC on circuit board and TFT-LCD panel, and so it is easy to be affected by electrostatics. Please be careful with electrostatics by the way of your body connecting to the ground and so on.
- (2) Please remove protection film very slowly on the surface of LCD module to prevent from electrostatics occurrence.

10.4 STORAGE PRECAUTIONS

- (1) When you store LCDs for a long time, it is recommended to keep the temperature between 0°C ~40°C without the exposure of sunlight and to keep the humidity less than 90%RH.
- (2) Please do not leave the LCDs in the environment of high humidity and high temperature such as 60°C 90%RH.
- (3) Please do not leave the LCDs in the environment of low temperature; below -20°C.

10.5 SAFETY PRECAUTIONS

- (1) When you waste LCDs, it is recommended to crush damaged or unnecessary LCDs into pieces and wash them off with solvents such as acetone and ethanol, which should later be burned.
- (2) If any liquid leaks out of a damaged-glass cell and comes in contact with the hands, wash off thoroughly with soap and water.

10.6 OTHERS

- (1) A strong incident light into LCD panel might cause display characteristics' changing inferior because of polarizer film, color filter, and other materials becoming inferior. Please do not expose LCD module direct sunlight and strong UV rays.
- (2) Please pay attention to a panel side of LCD module not to contact with other materials in preserving it alone.
- (3) For the packaging box, please pay attention to the followings:
 - Packaging box and inner case for LCD are designed to protect the LCDs from the damage or scratching during transportation. Please do not open except picking LCDs up from the box.
 - Please do not pile them up more than 3 boxes. (They are not designed so.) And please do not turn over.
 - Please handle packaging box with care not to give them sudden shock and vibrations. And also please do not throw them up.

Packing box and inner case for LCDs are made of cardboard. So please pay attention not to get them wet. (Such like keeping them in high humidity or wet place can occur getting them wet.)