



Chunghwa Picture Tubes, Ltd.

Technical Specification

To : SCL
Date : 2011/08/01

TFT LCD
CLAA156WB13A



APPROVED BY	CHECKED BY	PREPARED BY
Ronald Huang	Alan Shih	Carol Shen

Prepared by :
 FAE Division
 VD Business Unit
 CHUNGHWA PICTURE TUBES, LTD.
 1127 Hopin Rd., Padeh, Taoyuan, Taiwan 334, R.O.C.
 TEL: +886-3-3675151 FAX: +886-3-377-3003

Doc.No:	CLAA156WB11A-Wistron-V1-2011/02/12	Issue Date:	2011/02/12
---------	------------------------------------	-------------	------------

1. OVERVIEW

CLAA156WB13A is 15.6" color (16 : 9) TFT-LCD (Thin Film Transistor Liquid Crystal Display) module composed of LCD panel, LVDS driver ICs, control circuit and backlight. By applying 6 bit digital data, 1366×RGB (3) ×768, 262K-color images are displayed on the 15.6" diagonal screen. General specifications are summarized in the following table :

ITEM	SPECIFICATION
Display Area	344.232(H) x 193.536(V) (mm) (15.6-inch diagonal)
Number of Pixels	1366 x 3 (RGB) x 768
Pixel Pitch	0.252(H) x 0.252(V) (mm)
Color Pixel Arrangement	RGB vertical stripe
Display Mode	Normally white
Number of Colors	262,144(6bits) (LVDS)
Gamut	56%(min)/60% (Typ)
Optimum Viewing Angle	6 o'clock
Response Time	16ms (Typ)
Surface Treatment	Glare
Viewing Angle	40°、-40°/15°、-30° (MIN.)
Brightness	220 cd/m ² (5point) (Typ)
Uniformity	5point : 80%
Consumption of Power	5W (Max)
Module Size	359.8(W)×210(H)×5.5(D) (mm) (Max)
Module Weight (g)	450 g (Max)

The LCD Products listed on this document are not suitable for use of aerospace equipment, submarine cable, and nuclear reactor control system and life support systems. If customers intend to use these LCD products for applications listed above or those not included in the "Standard" list as follows, please contact our sales in advance.

Standard : Computer, Office equipment, Communication equipment, Test and Measurement equipment, Machine tool, Industrial robot, Audio and Visual equipment, Other consumer products.

2. ABSOLUTE MAXIMUM RATINGS

The following are maximum value, which if exceeded, may cause faulty operation or damage to the unit.

ITEM	SYMBOL	MIN	MAX	UNIT	NOTE
LCD Power Voltage	VCC	0	4.0	V	
LED Driver Input Voltage	VBL+	7	21	V	
Operation Temperature	Top	0	50	°C	*1).*2).*3).*4).
Storage Temperature	Tstg	-25	65	°C	*1).*2).*3).

【Note】

- *1) The relative temperature and humidity range are as below sketch, 90%RH Max. ($T_a \leq 40^\circ\text{C}$)
- *2) The maximum wet bulb temperature $\leq 39^\circ\text{C}$ ($T_a > 40^\circ\text{C}$) and without dewing.
- *3) If product in environment which over the definition of the relative temperature and humidity out of range too long, it will affect visual of LCD.
- *4) If you operate LCD in normal temperature range, the center surface of panel should be under 50°C .

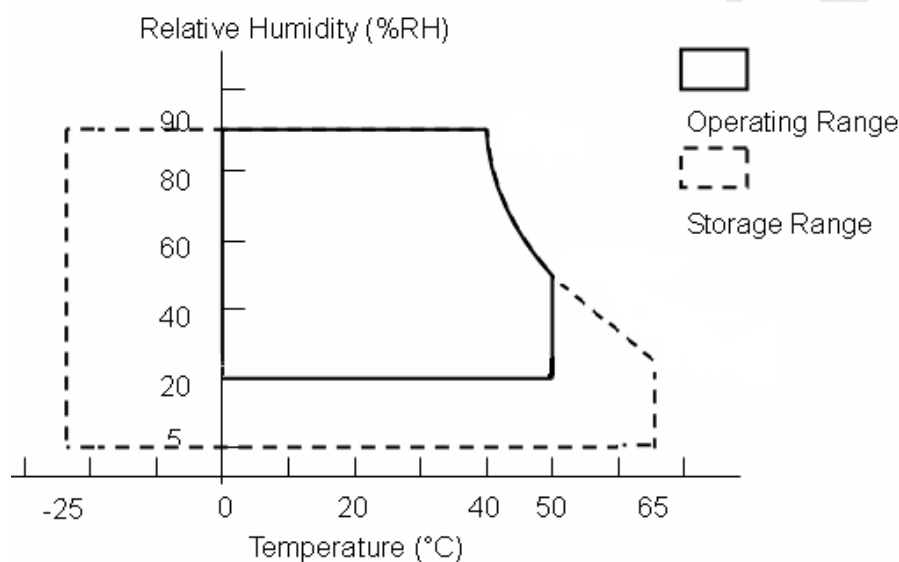

3. ELECTRICAL CHARACTERISTICS

(A) TFT LCD

ITEM	SYMBOL	MIN	TYP	MAX	UNIT	NOTE	
LCD Power Voltage	VCC	3.0	3.3	3.6	V	*1)	
LCD Power Current	ICC	-	303	333	mA	*2)	
Rush Current	Irush	-	-	2	A	*4)	
Logic Input Voltage (LVDS: IN+,IN-)	Common Voltage	VCM	1.125	1.25	1.375	V	*3)
	Differential Input Voltage	VID	250	350	450	mV	*3)
	Threshold Voltage (HIGH)	VTH	-	-	100	mV	*3)
	Threshold Voltage (LOW)	VTL	-100	-	-	mV	When VCM = +1.2V

【Note】

*1) Power Sequence :

$$0.50 \text{ ms} \leq t1 \leq 10 \text{ ms}$$

$$0.01 \text{ ms} < t2 \leq 50 \text{ ms}$$

$$0.01 \text{ ms} < t3 \leq 50 \text{ ms}$$

$$500 \text{ ms} \leq t4$$

$$200 \text{ ms} \leq t5$$

$$200 \text{ ms} \leq t6$$

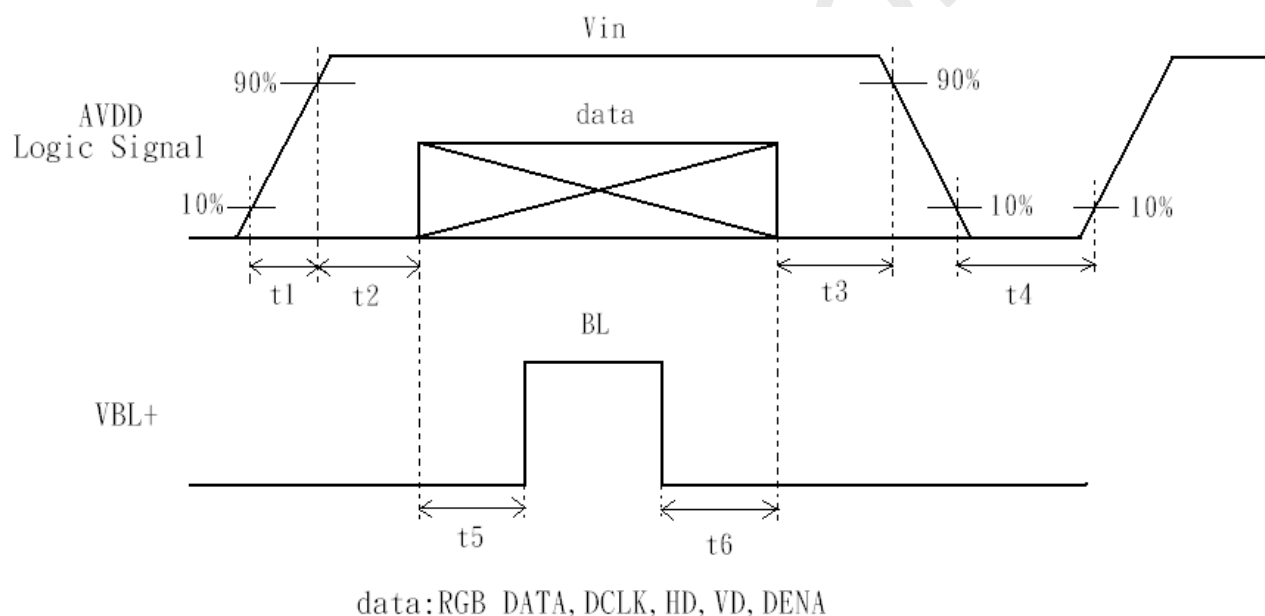

VCC-dip state

(1) when $3.0\text{V} > \text{VCC} \geq 2.7\text{V}$, $t_d \leq 10 \text{ ms}$.

(2) when $\text{VCC} < 2.7\text{V}$, VCC-dip condition should as the VCC-turn-off condition.

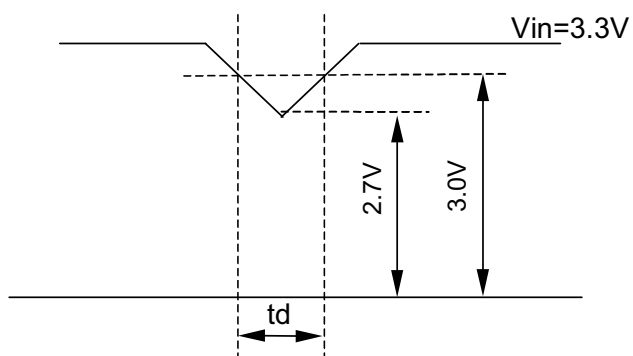

*2) Typical value is Mosaic (32*36 Checker board) Pattern : 768 line mode.

Circuit condition (Typ) : $V_{CC}=3.3 V$, $f_V=60 Hz$ $f_H=48.36 kHz$, $f_{CLK}=75.44 MHz$

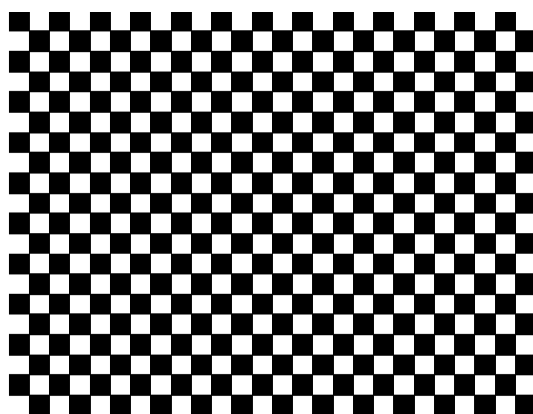

Max value is Black Pattern : 768 line mode.

Circuit condition (Max) : $V_{CC}=3.3 V$, $f_V=60 Hz$ $f_H=48.36 kHz$, $f_{CLK}=75.44 MHz$

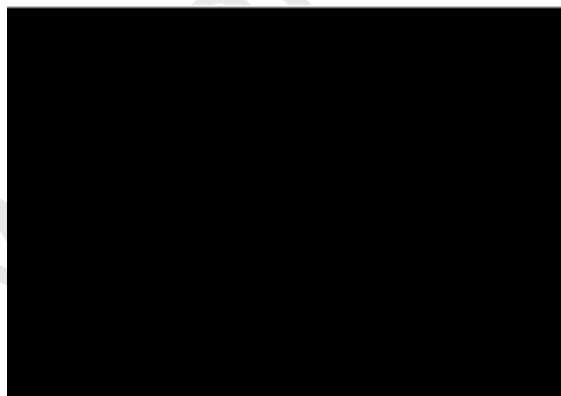

*3) LVDS Signal Definite :

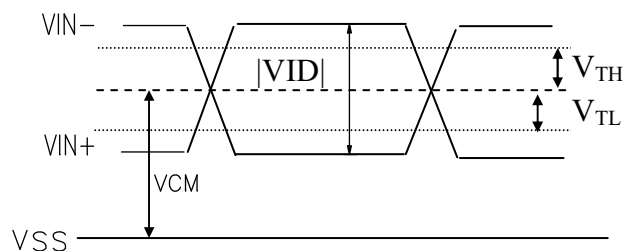
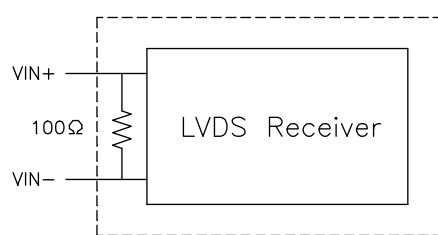

VIN+ : Positive differential DATA & CLK Input

VIN- : Negative differential DATA & CLK Input

*4) Irush measure condition

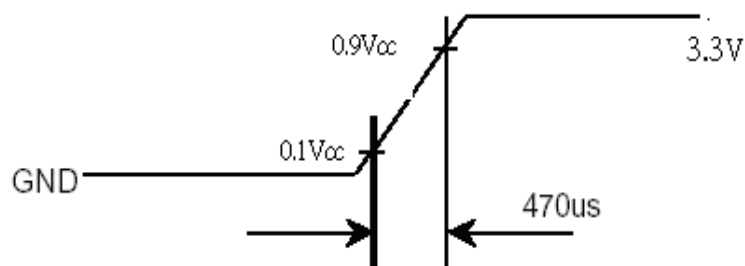
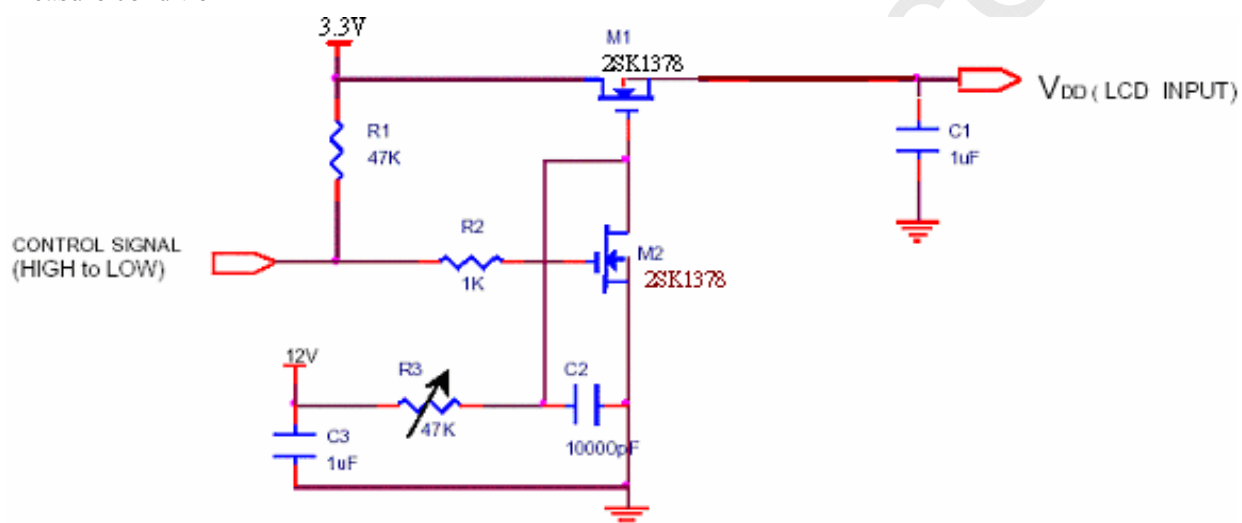

(B) BACK LIGHT

(a.) ELECTRICAL CHARACTERISTICS

Ta=25°C

ITEM	SYMBOL	MIN	TYP	MAX	UNIT	NOTE
LED Driver Input Voltage	VBL+	7	12	21	V	
LED Driver Input Current	IBL+			650	mA	*1)
Forward Voltage	V _F	2.9	3.2	3.5	V	*2) I _F =20mA
Forward Current	I _F	19.5	20	20.5	mA	*2)
Power Consumption	PLED	-	3.614	3.953	W	*2)*3) I _F =20mA
PWM Frequency	PWM_BL	180	200	1k	Hz	*2)I _F =20mA
Duty ratio	Dim	5		100	%	

(b.) LED LIFE – TIME

ITEM	CONDITION	MIN	TYP	MAX	UNIT	NOTE
Life Time	I _F =20mA · Ta=25°C	15000			hrs	*4)

(c.) LED ON/OFF Sequence :

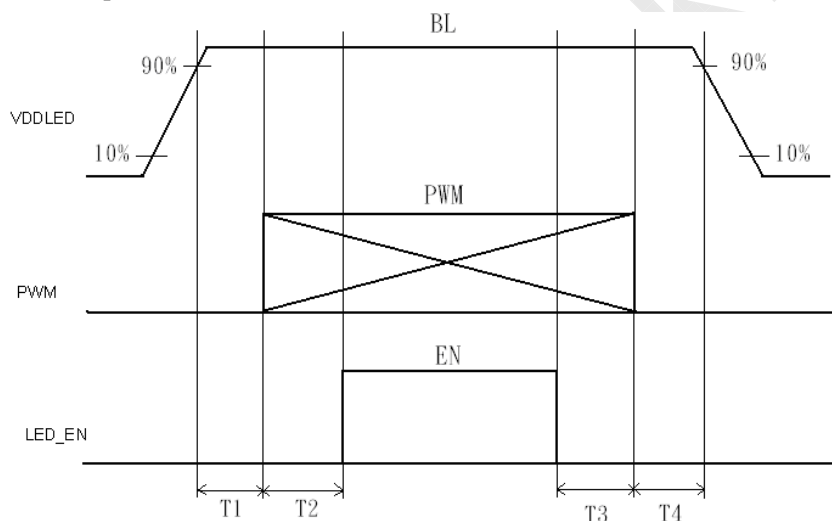

$$10\text{ms} \leq T1$$

$$0\text{ms} \leq T3$$

$$10\text{ms} \leq T2$$

$$10\text{ms} \leq T4$$

- *1) Maximum LED Driver Input Current at 7V Input Voltage/PWM Duty 100%.
- *2) Measure method : a. LED current is measured by utilizing a current meter as show below.
b. System power PLED is measured at input voltage 12V.

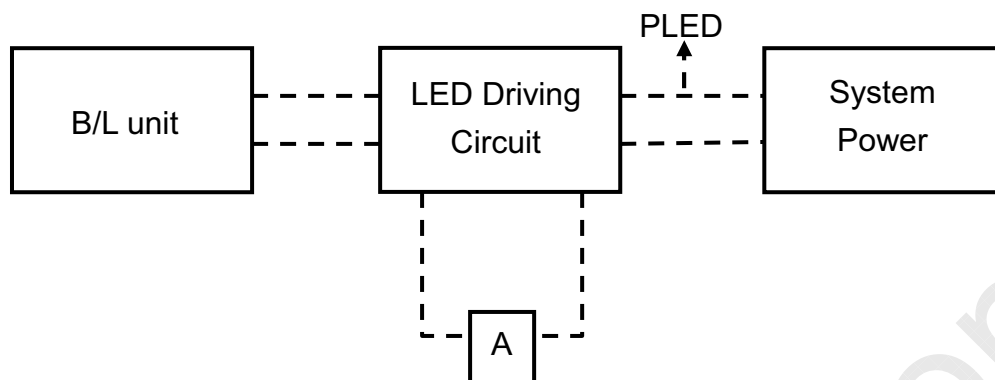

- *3) Calculator value for reference $I_F \times V_F \times N = PLED$
- *4) Life time means that estimated time to 50% degradation of initial luminous intensity.

4. Connector Interface PIN & Function

CN (Interface signal)

Outlet connector: 5-2069716-3 (TYCO) or compatible

Pin No.	SYMBOL	FUNCTION
1	NC	No connection
2	VDD	Power Supply, 3.3 V (typical)
3	VDD	Power Supply, 3.3 V (typical)
4	V EEDID	DDC 3.3V power
5	NC	No connection
6	Cik EEDID	DDC Clock
7	DATA EEDID	DDC Data
8	Odd_Rin0-	- LVDS differential data input (R0-R5, G0) (odd pixels)
9	Odd_Rin0+	+ LVDS differential data input (R0-R5, G0) (odd pixels)
10	VSS	Ground – Shield
11	Odd_Rin1-	- LVDS differential data input (G1-G5, B0-B1) (odd pixels)
12	Odd_Rin1+	+ LVDS differential data input (G1-G5, B0-B1) (odd pixels)
13	VSS	Ground – Shield
14	Odd_Rin2-	- LVDS differential data input (B2-B5, HS, VS, DE) (odd pixels)
15	Odd_Rin2+	+ LVDS differential data input (B2-B5, HS, VS, DE) (odd pixels)
16	VSS	Ground – Shield
17	Odd_CikIN-	- LVDS differential clock input (odd pixels)
18	Odd_CikIN+	+ LVDS differential clock input (odd pixels)
19	NC	No connection
20	NC	No connection
21	NC	No connection
22	NC	No connection
23	NC	No connection
24	NC	No connection
25	NC	No connection
26	NC	No connection
27	NC	No connection
28	NC	No connection
29	NC	No connection
30	NC	No connection
31	VSSLED	Ground – LED
32	VSSLED	Ground – LED
33	VSSLED	Ground – LED
34	NC	No connection
35	PWM	System PWM Signal Input (+3.3V Swing)
36	LED_EN	LED enable pin (+3.3V Input)
37	NC	No connection
38	VDDLED	7V – 21V LED power
39	VDDLED	7V – 21V LED power
40	VDDLED	7V – 21V LED power

5. INTERFACE TIMING CHART

(1)(a). LVDS input time sequence

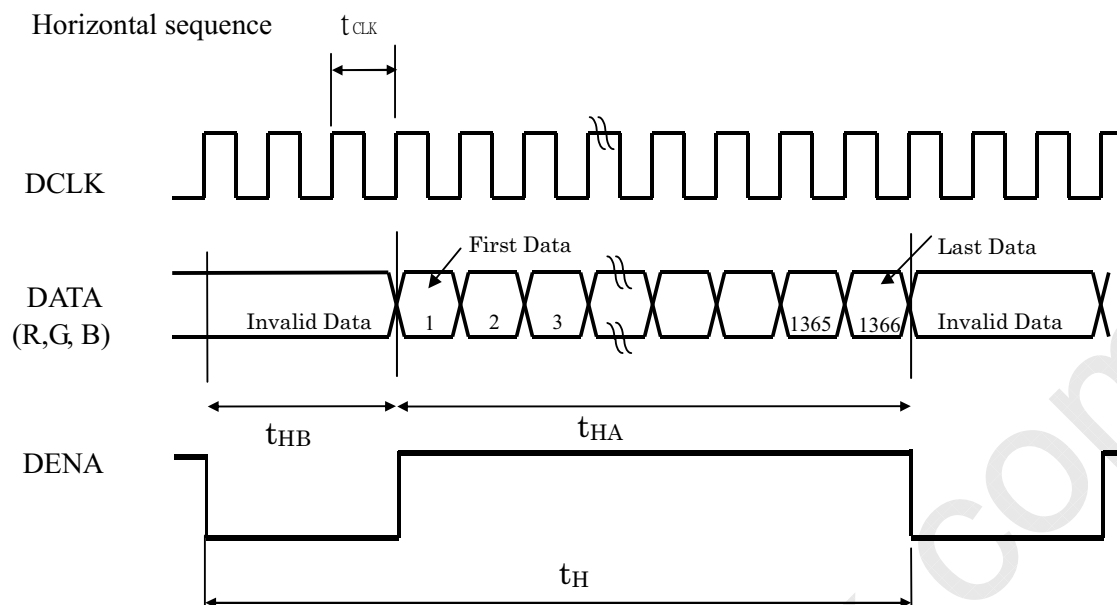

(b) LCD input time sequence

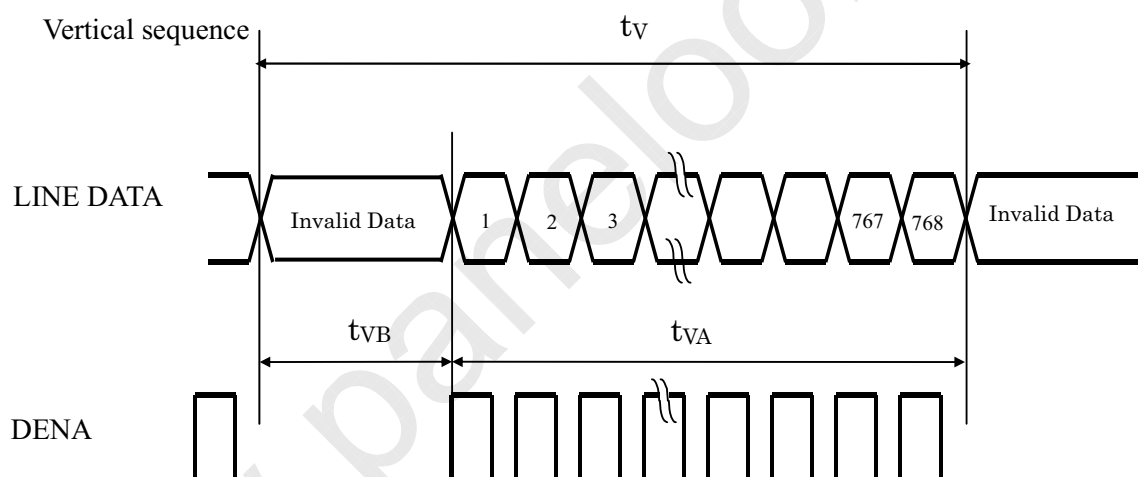

(2) Timing Chart

ITEM			SYMBOL	MIN	TYP	MAX	UNIT	
LCD Timing	Frame Rate		-	--	60	--	Hz	
	DCLK		Frequency	f_{CLK}	65.93	75.44	80.00	MHz
			Period	t_{CLK}	11.26	13.25	15.17	ns
	DENA	Horizontal	Horizontal total time	t_H	1498	1560	1667	t_{CLK}
			Horizontal Active time	t_{HA}	1366	1366	1366	t_{CLK}
			Horizontal Blank time	t_{HB}	132	194	301	t_{CLK}
		Vertical	Vertical total time	t_V	800	806	870	t_H
			Vertical Active time	t_{VA}	768	768	768	t_H
			Vertical Blank time	t_{VB}	32	38	102	t_H
LVDS spread spectrum range *3)				-2		2	%	

【Note】

- *1) DENA (DATA ENABLE) usually is positive.
- *2) During the whole blank period, DCLK should keep input.
- *3) LVDS input clock is 85MHz and modulation rate is fixed 100KHz.
- *4) MAX set conditions: H-total / V-total can not set the max for the same time

(3) DATA mapping

Color	Input Data	R DATA						G DATA						B DATA					
		R5	R4	R3	R2	R1	R0	G5	G4	G3	G2	G1	G0	B5	B4	B3	B2	B1	B0
		MS B					LS B	MS B					LS B	MS B					LS B
Basic Color	Black	0	0	0	0	0	0	0	0	0	0	0	0	0	0	0	0	0	0
	Red(63)	1	1	1	1	1	1	0	0	0	0	0	0	0	0	0	0	0	0
	Green(63)	0	0	0	0	0	0	1	1	1	1	1	1	0	0	0	0	0	0
	Blue(63)	0	0	0	0	0	0	0	0	0	0	0	0	1	1	1	1	1	1
	Cyan	0	0	0	0	0	0	1	1	1	1	1	1	1	1	1	1	1	1
	Magenta	1	1	1	1	1	1	0	0	0	0	0	0	1	1	1	1	1	1
	Yellow	1	1	1	1	1	1	1	1	1	1	1	1	0	0	0	0	0	0
	White	1	1	1	1	1	1	1	1	1	1	1	1	1	1	1	1	1	1
RED	RED(0)	0	0	0	0	0	0	0	0	0	0	0	0	0	0	0	0	0	0
	RED(1)	0	0	0	0	0	1	0	0	0	0	0	0	0	0	0	0	0	0
	RED(2)	0	0	0	0	1	0	0	0	0	0	0	0	0	0	0	0	0	0
	RED(62)	1	1	1	1	1	0	0	0	0	0	0	0	0	0	0	0	0	0
	RED(63)	1	1	1	1	1	1	0	0	0	0	0	0	0	0	0	0	0	0
	Green	Green(0)	0	0	0	0	0	0	0	0	0	0	0	0	0	0	0	0	0
Green(1)		0	0	0	0	0	0	0	0	0	0	0	1	0	0	0	0	0	0
Green(2)		0	0	0	0	0	0	0	0	0	0	1	0	0	0	0	0	0	0
Green(62)		0	0	0	0	0	0	1	1	1	1	1	0	0	0	0	0	0	0
Green(63)		0	0	0	0	0	0	1	1	1	1	1	1	0	0	0	0	0	0
Blue	Blue(0)	0	0	0	0	0	0	0	0	0	0	0	0	0	0	0	0	0	0
	Blue(1)	0	0	0	0	0	0	0	0	0	0	0	0	0	0	0	0	0	1
	Blue(2)	0	0	0	0	0	0	0	0	0	0	0	0	0	0	0	0	1	0
	Blue(62)	0	0	0	0	0	0	0	0	0	0	0	0	1	1	1	1	1	0
	Blue(63)	0	0	0	0	0	0	0	0	0	0	0	0	1	1	1	1	1	1

【Note】

1) Gray level:

Color(n) : n is level order; higher n means brighter level.

2) DATA:

1: high , 0: low

6. BLOCK DIAGRAM

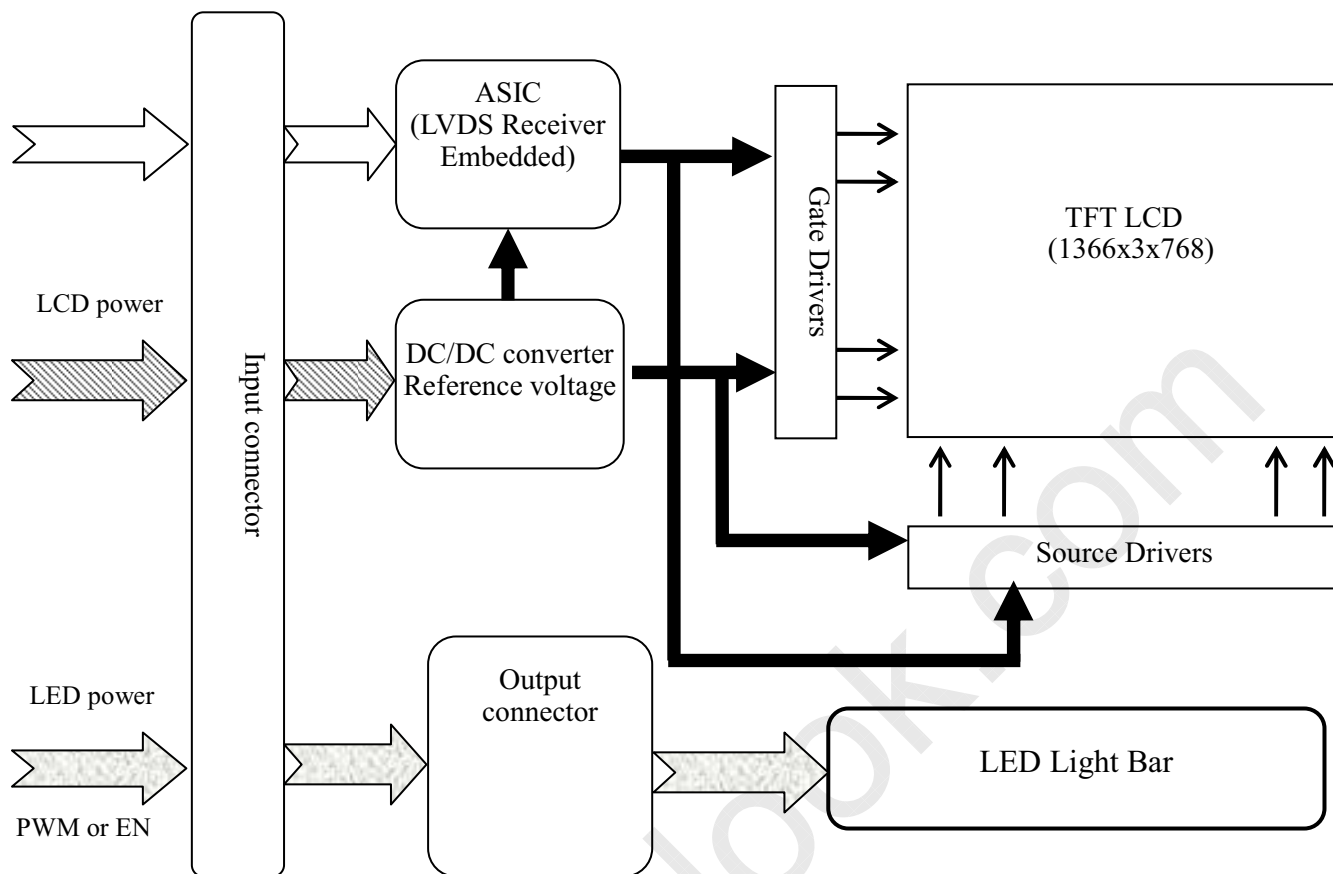

7. MECHANICAL SPECIFICATION

(1) Front side

The tolerance, not show in the figure, is ± 0.5 mm.

[Unit : mm]

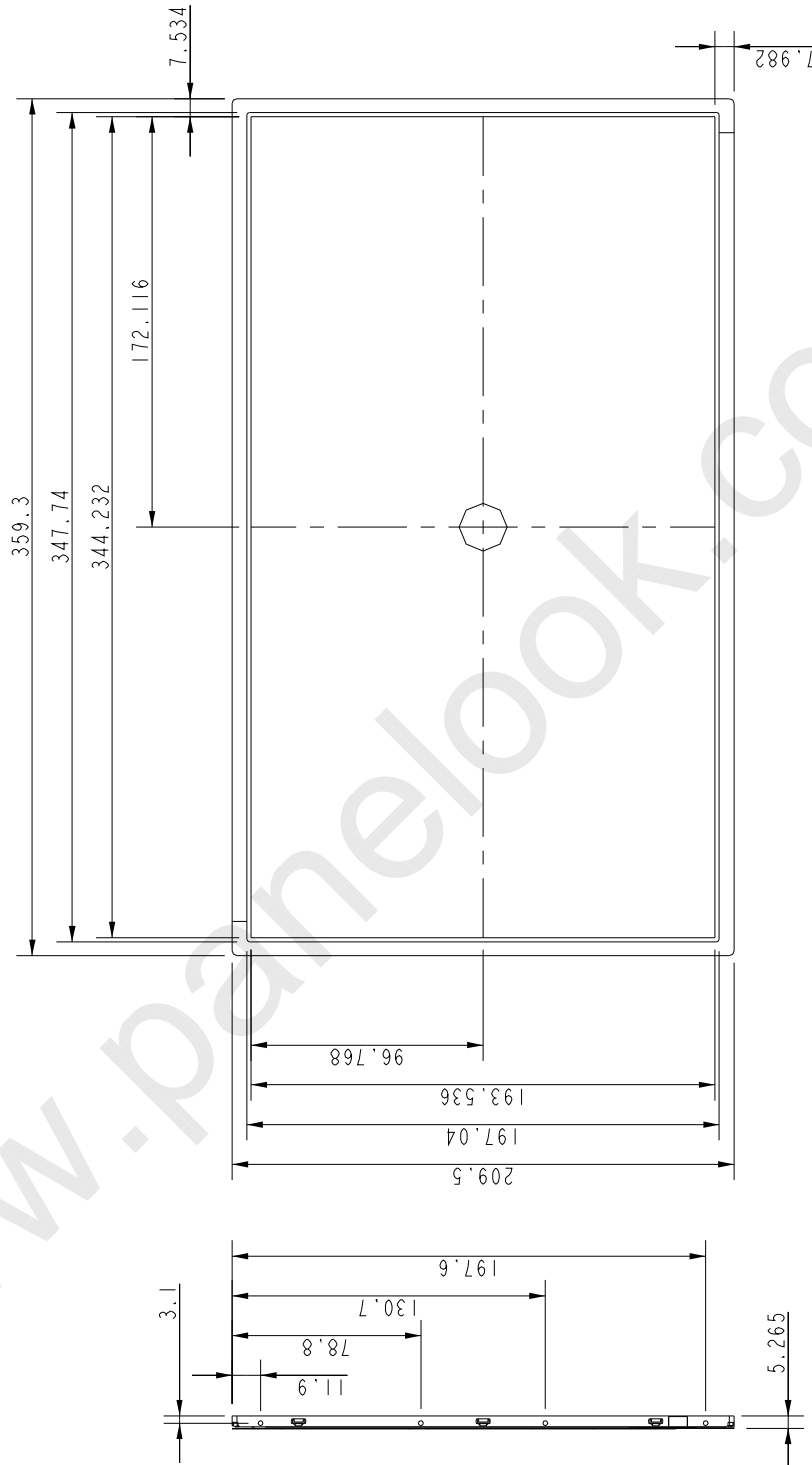

(2) Rear side

The tolerance, not show in the figure, is ± 0.5 mm.

[Unit : mm]

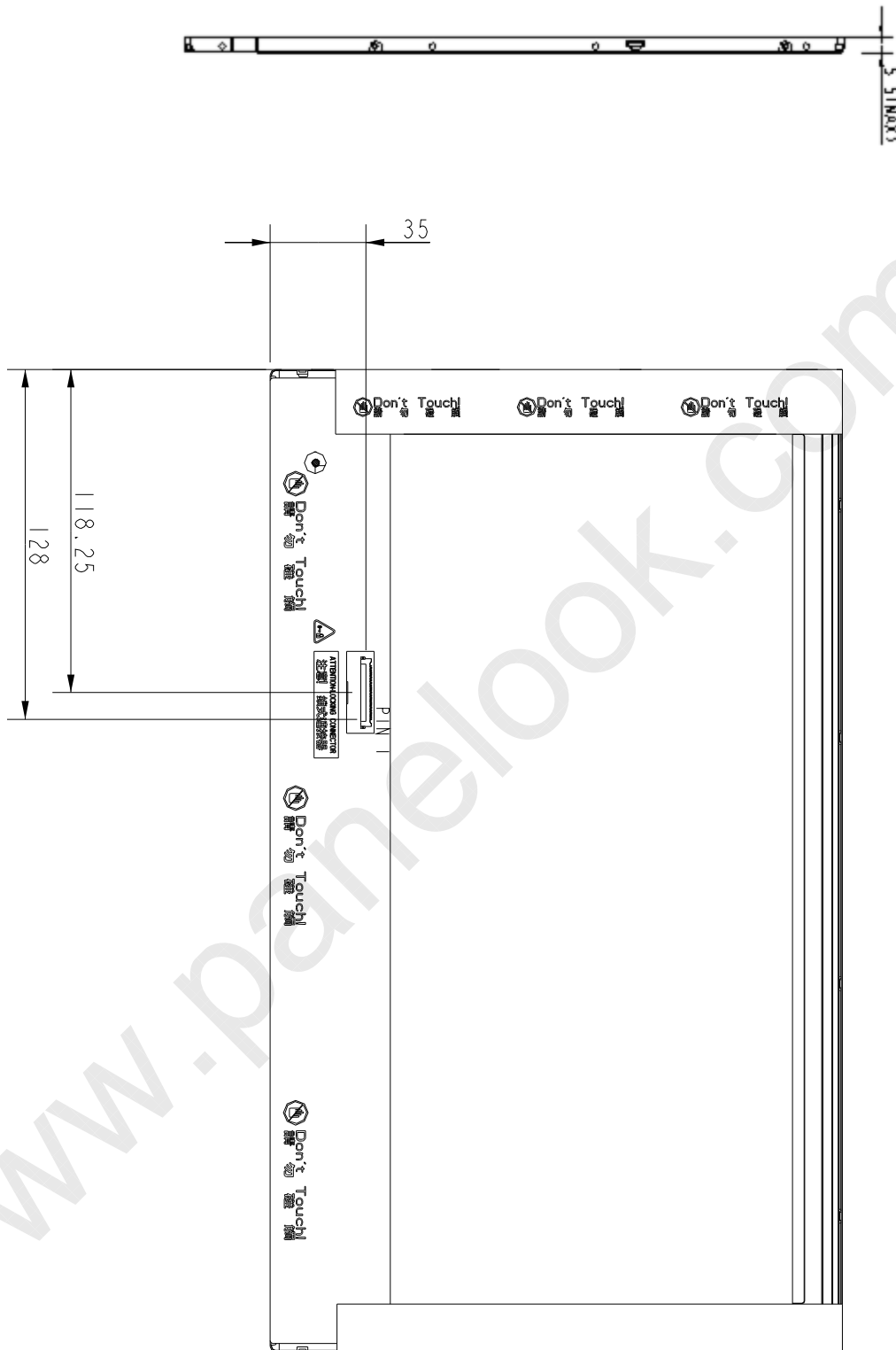

8. OPTICAL CHARACTERISTICS

Ta=25°C , VDD=3.3V

ITEM		SYMBOL	CONDITION	MIN	TYP	MAX	UNIT	NOTE
Contrast Ratio		CR	$\theta = \psi = 0^\circ$	500	600		--	*1) 2)
Luminance (5P)		L	$\theta = \psi = 0^\circ$	200	220		cd/m ²	*1) 3)
Uniformity(5P)		ΔL	$\theta = \psi = 0^\circ$	80			%	*1) 3)
Response Time		Tr	$\theta = \psi = 0^\circ$		6	9	ms	*5)
		Tf	$\theta = \psi = 0^\circ$		10	16	ms	*5)
Cross Talk		CT	$\theta = \psi = 0^\circ$			1	%	*6)
View Angle	Horizontal	ψ	$CR \geq 10$	40/-40			°	*4)
	Vertical	θ		15/-30			°	*4)
Color Temperature Coordinate	W	X	$\theta = \psi = 0^\circ$	0.293	0.313	0.333		*3)
		Y		0.309	0.329	0.349		
	R	X		0.590	0.620	0.650		
		Y		0.310	0.340	0.370		
	G	X		0.300	0.330	0.360		
		Y		0.540	0.570	0.600		
	B	X		0.120	0.150	0.180		
Y		0.030	0.060	0.090				
Gamut			$\theta = \psi = 0^\circ$	56%	60%			
Gamma		γ	GL	2.0	2.2	2.4		*7)

Color coordinate and color gamut are measured by SRUL1R, response time is measured by TRD-100, and all the other items are measured by BM-5A (TOPCON). All these items are measured under the dark room condition (no ambient light).

Measurement Condition: IL= 20mA (each LED)

Definition of these measurement items is as follows:

***1) Setup of Measurement Equipment**

The LCD module should be turn-on to a stable luminance level to be reached. The measurement should be executed after lighting Backlight for 20 minutes and in a dark room.

***2) Definition of Contrast Ratio**

CR=ON (White) Luminance/OFF (Black) Luminance

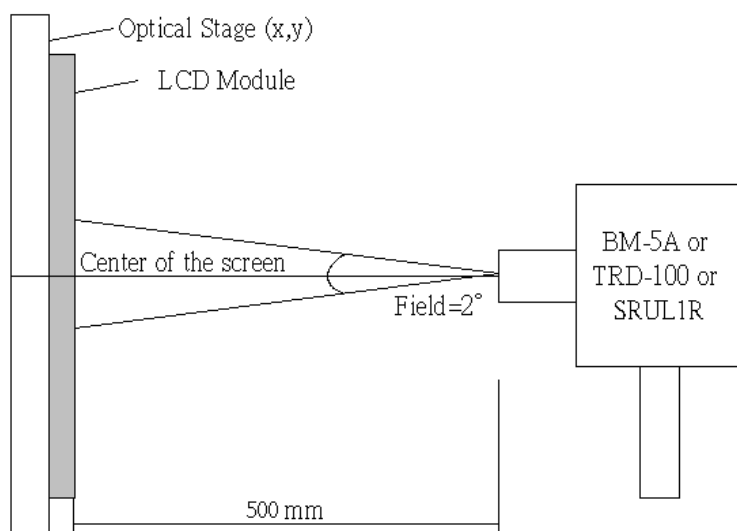

*3) Definition of Luminance and Luminance uniformity

Central luminance: The white luminance is measured at the center position "5" on the screen, see Fig.1 below.

5P Luminance (AVG): The white luminance is measured at measuring points 5 · 10 · 11 · 12 · 13, see Fig.1 below.

5P Uniformity: $\Delta L = (L_{min} / L_{max}) \times 100\%$

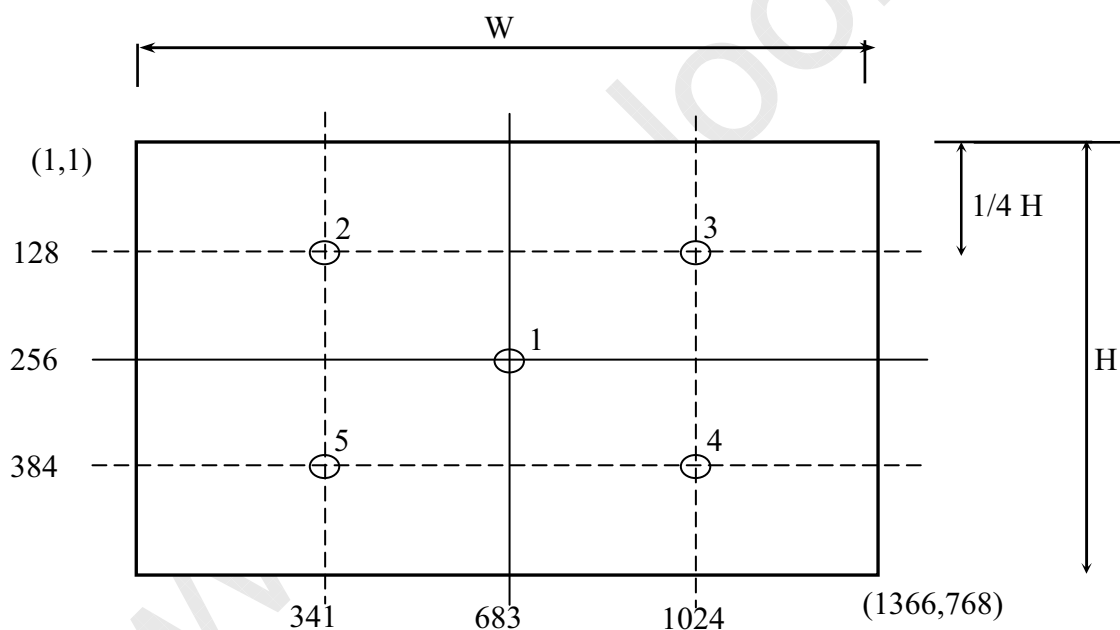

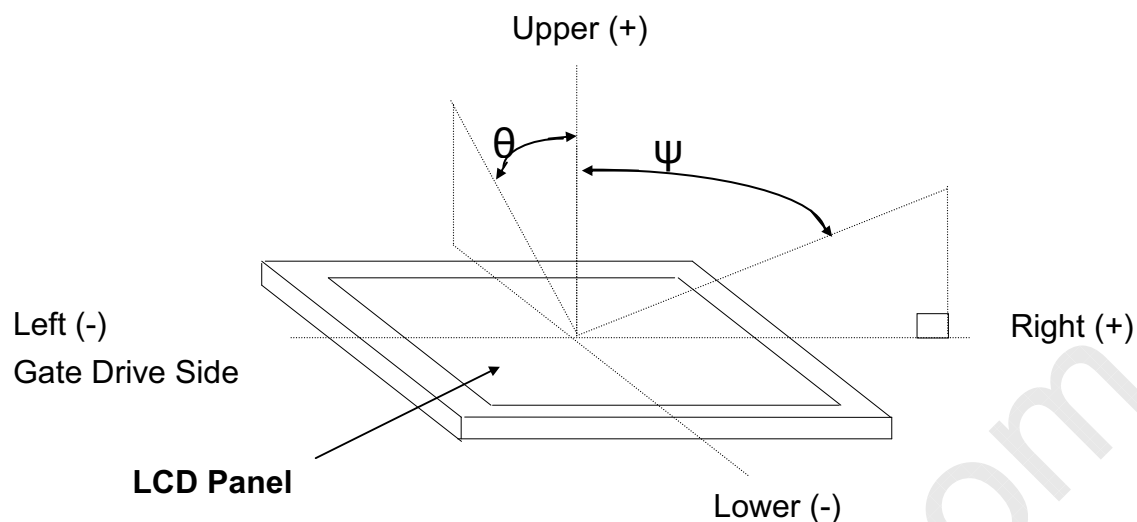
*4) Definition of view angle(θ , ψ)

*5) Definition of response time

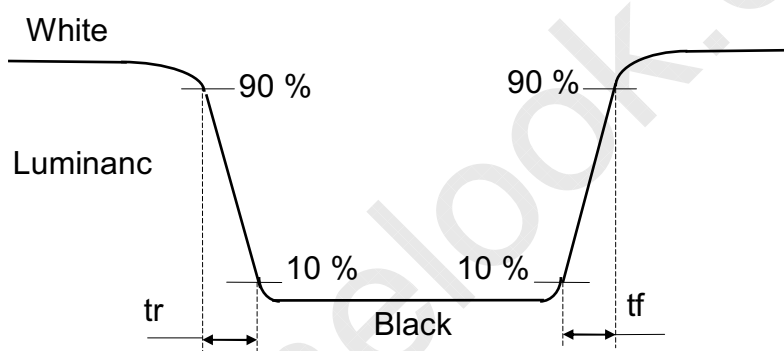

*6) Crosstalk Modulation Ratio:

$$CT = |Y_B - Y_A| / Y_A \times 100\%$$

Y_A 、 Y_B measure position and definition

Y_A means luminance at gray level 31(exclude gray level 0 pattern)

Y_B means luminance at gray level 31(include gray level 0 pattern)

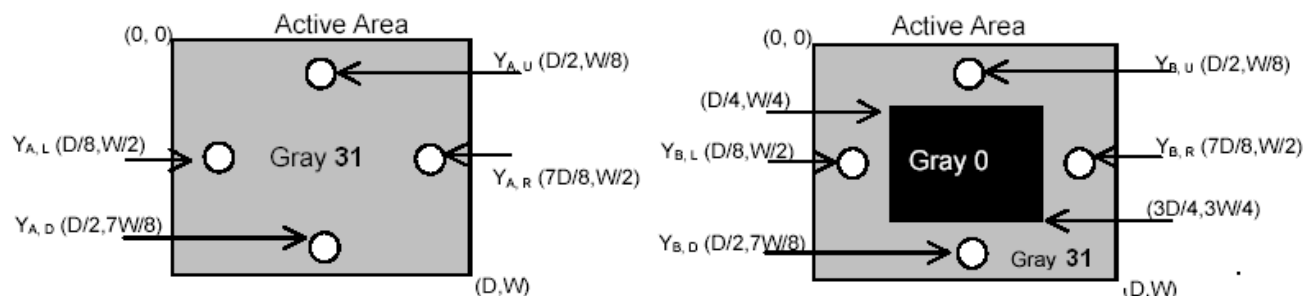

***7) Definition of Gamma (VESA)**

Based on Customer Sample, take the average value as a standard center value and the variation range of gamma value caused by loop voltage error should be between +/- 0.2. the bellow figure shows how to obtain the gamma curve and γ (from gray level: 0、4、8-----60、63).

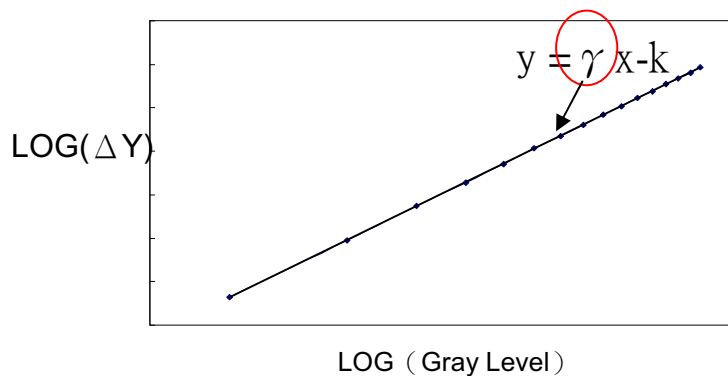

9. RELIABILITY TEST CONDITIONS

(1) Temperature and Humidity

TEST ITEMS	CONDITIONS
High Temperature Operation	50° C ; 250Hrs
High Temperature Storage	65° C ; 250Hrs
High Temperature High Humidity Operation	40° C ; 95% RH ; 250Hrs
High Temperature High Humidity Storage	60° C ; 90% RH ; 48 Hrs
Low Temperature Operation	0° C ; 250 Hrs
Low Temperature Storage	-30° C ; 250 Hrs
Thermal Shock	-40° C (0.5 Hr)~65° C (0.5 Hr), Ramp<20° C , 100 CYCLES
Temperature & Pressure Storage	-30° C ; 260hPa , 24 Hrs

(2) Shock & Vibration

TEST ITEMS	CONDITIONS
Shock (Non-Operation)	210G, 3ms, half sine wave, ± X,± Y,± Z 1time each
Vibration (Non-Operation)	Vibration level : 14.7m/s ² (1.5G), sinusoidal wave (each x, y, z axis : 1hr, total 3hrs) Frequency range : 5~500 Hz Sweep speed : 0.5 Octave/min.

(3) ESD

	Surface discharge(Panel display area · Frame · PWB · Panel back side)		Electrics capacity of Connector
	Contact	Air	Contact
Capacity	150 pF	150 pF	200 pF
Resistance	330 Ω	330 Ω	0 Ω
Voltage	±8kV	±15kV	±250 V
Interval	1 sec	1 sec	1 sec
Times(single point)	25	25	1

(4) MTBF without B/L: 200,000 Hrs (min) lifetimes.

(5) Judgment standard

The judgment of the above test should be made as follow:

Pass : Normal display image with no obvious non-uniformity and no line defect.

Partial transformation of the module parts should be ignored.

Fail : No display image, obvious non-uniformity, or line defects.