



Chunghwa Picture Tubes, Ltd.

Technical Specification

To : General
Date : 2012/12/17

TFT LCD
CLAA184FP01 XG

ACCEPTED BY :

APPROVED BY	CHECKED BY	PREPARED BY
		Product Planning Management Division

Prepared by :
Product Planning Management Division
VD Business Unit

CHUNGHWA PICTURE TUBES, LTD.

1127 Hopin Rd., Padeh, Taoyuan, Taiwan 334, R.O.C.
TEL: +886-3-3675151 FAX: +886-3-377-3003

Doc.No:	CLAA184FP01-General-V1-2012/12/17	Issue Date:	2012/12/17
---------	-----------------------------------	-------------	------------

Modification Record List

NO.	Issue Date	Modification Index
1	2012/12/17	Final version
2		
3		
4		
5		
6		
7		
8		
9		
10		

1. OVERVIEW

CLAA184FP01 is 18.4" color (16 : 9) TFT-LCD (Thin Film Transistor Liquid Crystal Display) module composed of LCD panel, LVDS driver ICs, control circuit and backlight. By applying 6 bit digital data, 1920×RGB (3) ×1080, 16.2M-color images are displayed on the 18.4" diagonal screen. General specifications are summarized in the following table :

ITEM	SPECIFICATION
Display Area	408.96 (H)×230.04(V)(mm) (18.4-inch diagonal)
Number of Pixels	1920 x 3 (RGB) x 1080
Pixel Pitch	0.213(H)×0.213(V) (mm)
Color Pixel Arrangement	RGB vertical stripe
Display Mode	Normally black
Number of Colors	16.2M(6bits+FRC)
Gamut	60% (Typ)
Optimum Viewing Angle	whole view
Response Time	40 (Typ) 、 50 (Max.)
Surface Treatment	Glare
Viewing Angle	80° 、 -80° /80° 、 -80° (Min.)
Brightness	350 cd/m ² (center) (Typ) 300 cd/m ² (center) (Min)
Uniformity	5point : 80%
Consumption of Power	8.8W (MAX)@White pattern
Module Size	422.5(W)×248(H)×6(D) (mm) (TYP)
Module Weight	650(g) (Max)

The LCD Products listed on this document are not suitable for use of aerospace equipment, submarine cable, and nuclear reactor control system and life support systems. If customers intend to use these LCD products for applications listed above or those not included in the "Standard" list as follows, please contact our sales in advance.

Standard : Computer, Office equipment, Communication equipment, Test and Measurement equipment, Machine tool, Industrial robot, Audio and Visual equipment, Other consumer products.

2. ABSOLUTE MAXIMUM RATINGS

The following are maximum value, which if exceeded, may cause faulty operation or damage to the unit.

ITEM	SYMBOL	MIN	MAX	UNIT	NOTE
Operation Temperature	Top	0	50	°C	*1).*2).*3).*4).
Storage Temperature	Tstg	-20	60	°C	*1).*2).*3).
LCD Power Voltage	VCC	0	4.0	V	
Forward Current (per LED)	If		30	mA	*5).
Reverse Voltage (per LED)	VR		5	V	
Pulse forward current (per LED)	Ifp		80	mA	*6).

【Note】

- *1) The relative temperature and humidity range are as below sketch, 90%RH Max. ($T_a \leq 40^\circ\text{C}$)
- *2) The maximum wet bulb temperature $\leq 39^\circ\text{C}$ ($T_a > 40^\circ\text{C}$) and without dewing.
- *3) If product in environment which over the definition of the relative temperature and humidity out of range too long, it will affect visual of LCD.
- *4) If you operate LCD in normal temperature range, the center surface of panel should be under 50°C .

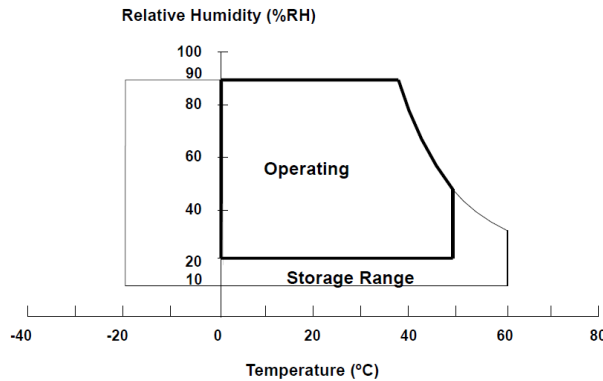

- *5) Each one of LED operation must be follow diagram of Ambient Temperature and Allowable Forward Current.

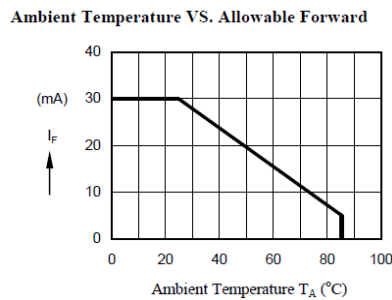

- *6) Ifp Conditions : Pulse Width $\leq 10\text{msec}$, Duty $\leq 1/10$ °

3. ELECTRICAL CHARACTERISTICS

(A) TFT LCD

ITEM	SYMBOL	MIN	TYP	MAX	UNIT	NOTE	
LCD Power Voltage	VCC	3.0	3.3	3.6	V	*1)	
LCD Power Current	ICC	-	700	830	mA	*2)	
Rush Current	Irush	-	-	2	A	*4)	
Logic Input Voltage (LVDS: IN+,IN-)	Common Voltage	VCM	1.125	1.25	1.375	V	*3)
	Differential Input Voltage	VID	250	350	450	mV	*3)
	Threshold Voltage (HIGH)	VTH	-	-	100	mV	*3) When VCM = +1.2V
	Threshold Voltage (LOW)	VTL	-100	-	-	mV	

【Note】

*1) Power Sequence :

$$0.50 \text{ ms} \leq t1 \leq 10 \text{ ms} \qquad 500 \text{ ms} \leq t4$$

$$0.01 \text{ ms} < t2 \leq 50 \text{ ms} \qquad 200 \text{ ms} \leq t5$$

$$0.01 \text{ ms} < t3 \leq 50 \text{ ms} \qquad 200 \text{ ms} \leq t6$$

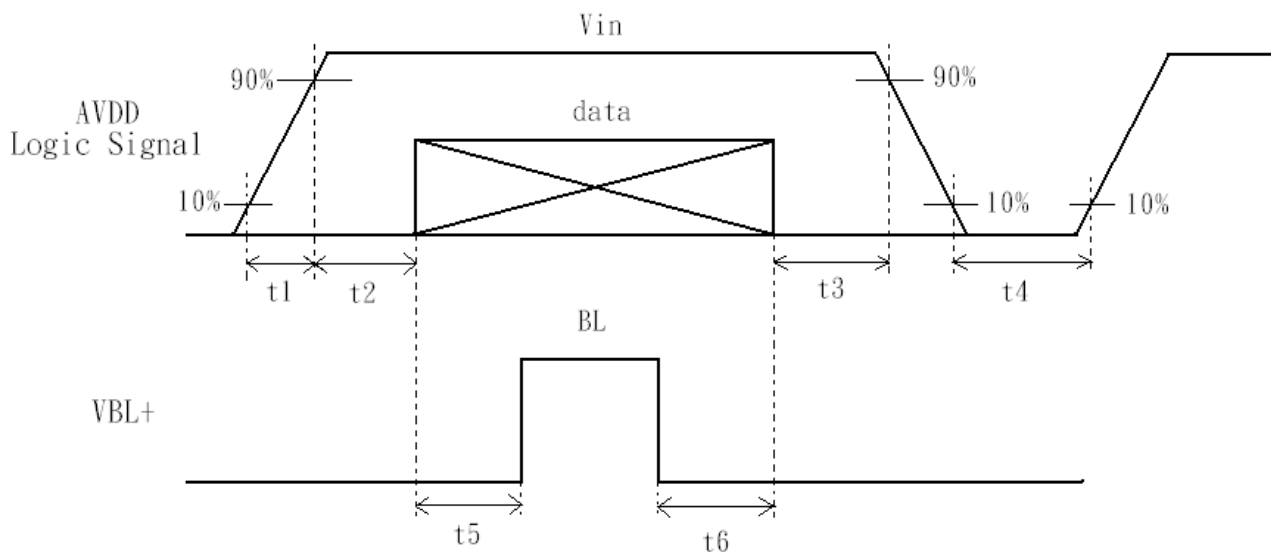

data:RGB DATA, DCLK, HD, VD, DENA

VCC-dip state

(1) when $3.0V > VCC \geq 2.7V$, $t_d \leq 10$ ms.

(2) when $VCC < 2.7V$, VCC-dip condition should as the VCC-turn-off condition.

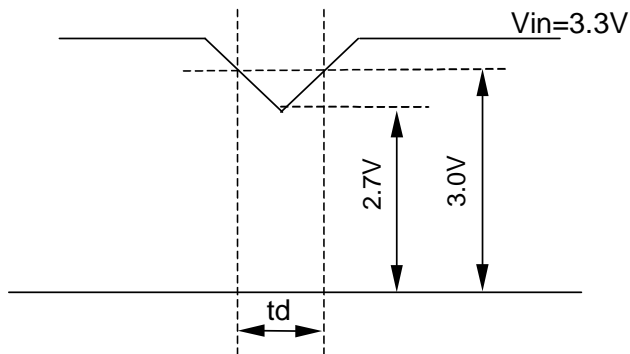

*2) Typical value is Mosaic (32*36 Checker board) Pattern : 1080 line mode.

Circuit condition (Typ) : $VCC=3.3$ V , $f_V=60$ Hz , $f_H=67.5$ kHz , $f_{CLK}=74.25$ MHz (one of LVDS dual port).

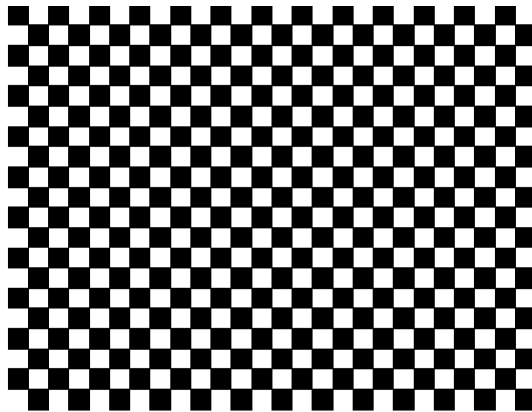

Max value is White Pattern : 1080 line mode.

Circuit condition (Max) : $VCC=3.3$ V , $f_V=60$ Hz , $f_H=67.5$ kHz , $f_{CLK}=74.25$ (one of LVDS dual port).

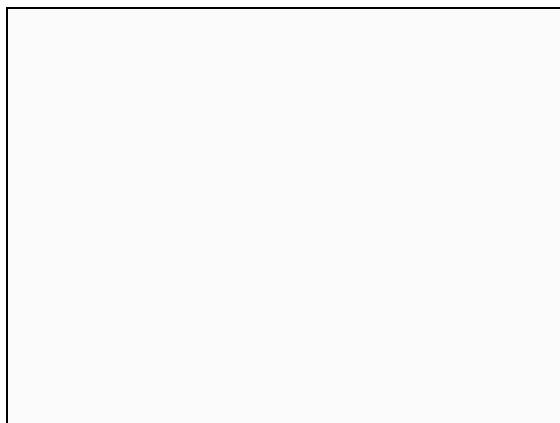

*3) LVDS Signal Definite :

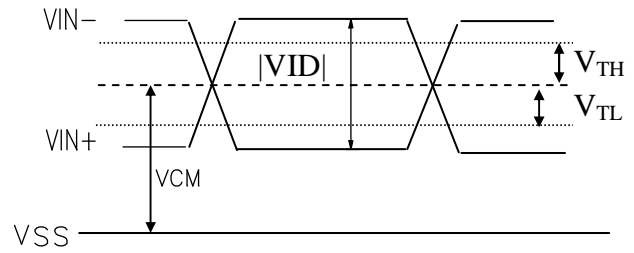
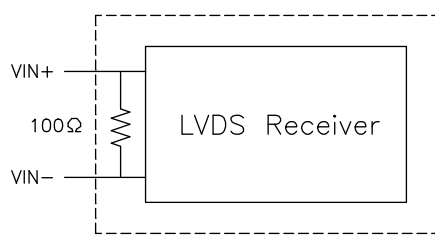

VIN+ : Positive differential DATA & CLK Input

VIN- : Negative differential DATA & CLK Input

*4) Irush measure condition

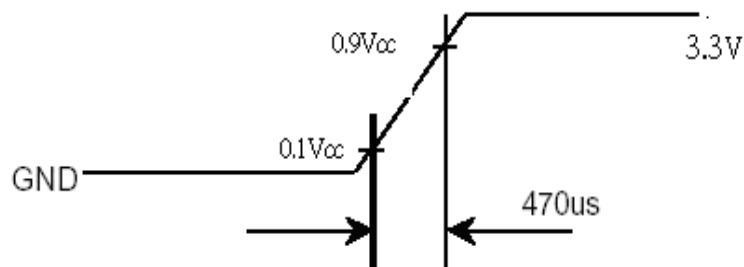
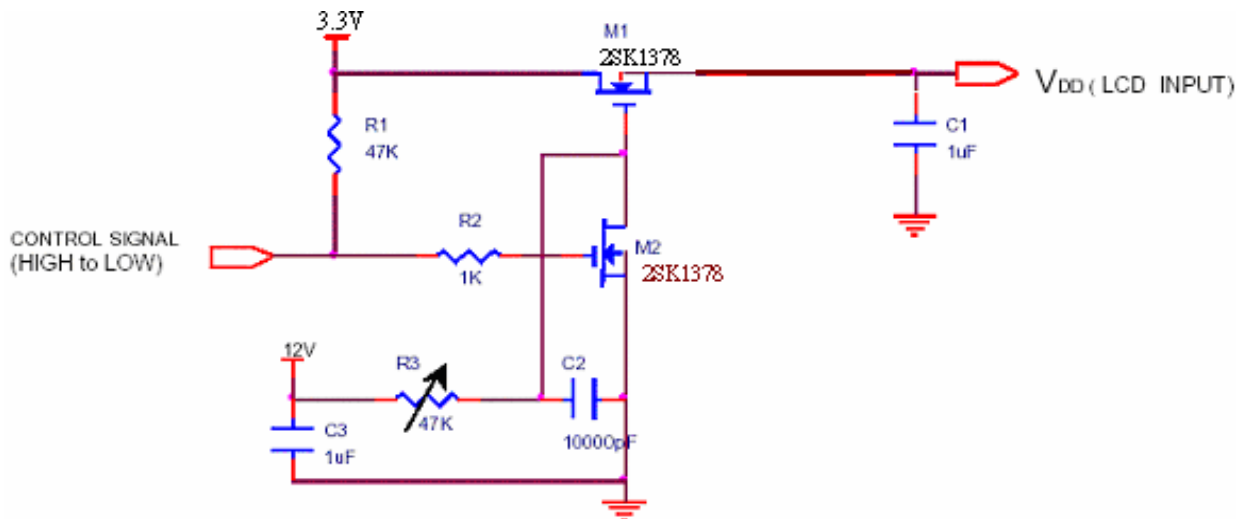

(B) BACK LIGHT

(a.) ELECTRICAL CHARACTERISTICS

ITEM	SYMBOL	MIN	TYP	MAX	UNIT	NOTE	
LED String Voltage	V_{LED}	26.1	28.8	31.5	V	*1) $I_F=20mA$	
LED String Current	I_{LED}	19.5	20	20.5	mA	*1)	
Power Consumption	PLED	5.22	5.76	6.3	W	*1)*2)	
PWM	Frequency	PWM_BL	180	200	1000	Hz	
	Duty ratio	Dim	10	-	100	%	
	Input Voltage	VH	2		2.7	V	
VL		0		0.8	V		

Ta=25°C

(b.) LED LIFE – TIME

ITEM	CONDITION	MIN	TYP	MAX	UNIT	NOTE
Life Time	$I_F=20mA$ · Ta=25°C	15000			hrs	*3)

*1) Measure method : LED current is measured by utilizing a current meter as show below.

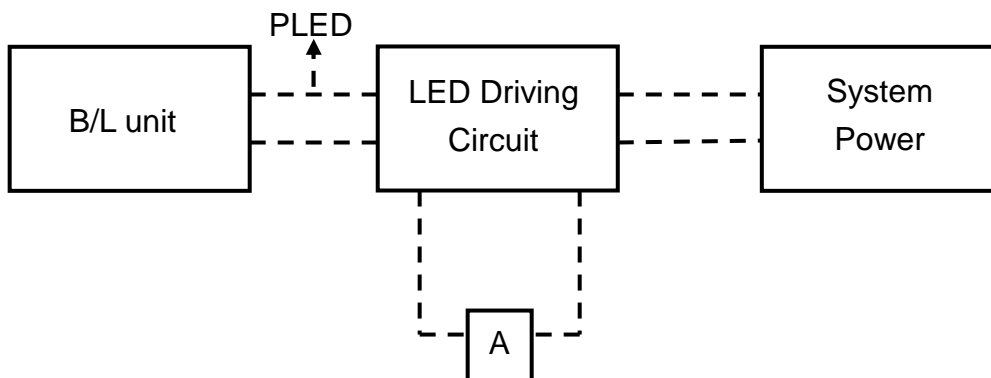

*2) Calculator value for reference $PLED = I_{LED} \times V_{LED} \times N$ (number of string), $N=10$ string.

*3) Life time means that estimated time to 50% degradation of initial luminous intensity.

4. Connector Interface PIN & Function

CN (Interface signal)

Outlet connector: 5-2069716-3 (TYCO) or equivalent

Pin No.	SYMBOL	FUNCTION
1	VCCS	Power Supply (3.3V+/- 0.3V)
2	VCCS	Power Supply (3.3V+/- 0.3V)
3	VCCS	Power Supply (3.3V+/- 0.3V)
4	VEDID	EDID Power(3.3V+/- 0.3V)
5	NC	No Connection (Reserved for CPT test)
6	CLKEDID	EDID Clock
7	DATAEDID	EDID Data
8	RXO0-	LVDS Differential Data Input (Odd)
9	RXO0+	LVDS Differential Data Input (Odd)
10	VSS	Ground
11	RXO1-	LVDS Differential Data Input (Odd)
12	RXO1+	LVDS Differential Data Input (Odd)
13	VSS	Ground
14	RXO2-	LVDS Differential Data Input (Odd)
15	RXO2+	LVDS Differential Data Input (Odd)
16	VSS	Ground
17	RXOC-	LVDS Clock Data Input (Odd)
18	RXOC+	LVDS Clock Data Input (Odd)
19	VSS	Ground
20	RXO3-	LVDS Differential Data Input (Odd)
21	RXO3+	LVDS Differential Data Input (Odd)
22	VSS	Ground
23	RXE0-	LVDS Differential Data Input (Even)
24	RXE0+	LVDS Differential Data Input (Even)
25	VSS	Ground
26	RXE1-	LVDS Differential Data Input (Even)
27	RXE1+	LVDS Differential Data Input (Even)
28	VSS	Ground
29	RXE2-	LVDS Differential Data Input (Even)
30	RXE2+	LVDS Differential Data Input (Even)
31	VSS	Ground
32	RXEC-	LVDS Clock Data Input (Even)
33	RXEC+	LVDS Clock Data Input (Even)
34	VSS	Ground
35	RXE3-	LVDS Differential Data Input (Even)
36	RXE3+	LVDS Differential Data Input (Even)
37	VSS	Ground
38	NC	No Connection (Reserved for CPT test)
39	NC	No Connection (Reserved for CPT test)
40	NC	No Connection (Reserved for CPT test)

B/L (LED) pin assignment:

Pin No.	FUNCTION
1	Power Supply (voltage out)(+28.8V)
2	Power Supply (voltage out) (+ 28.8V)
3	LED1 (-)
4	LED2 (-)
5	LED3 (-)
6	LED4 (-)
7	LED5 (-)
8	LED6 (-)
9	LED7 (-)
10	LED8 (-)
11	LED9 (-)
12	LED10 (-)

5. INTERFACE TIMING CHART

(1) Time Sequence

(a) LVDS input time sequence

Horizontal Signal

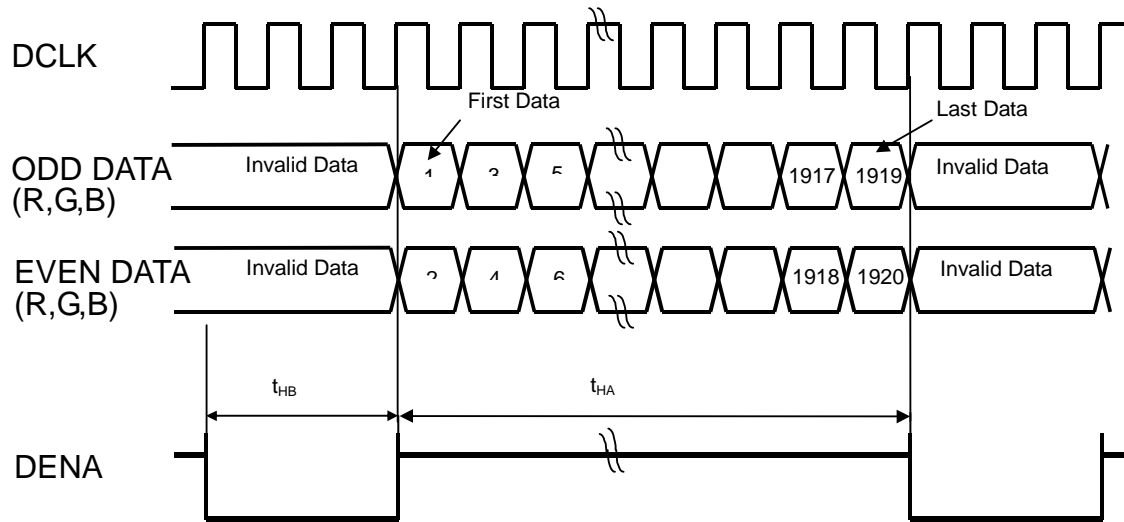

(b) LCD input time sequence

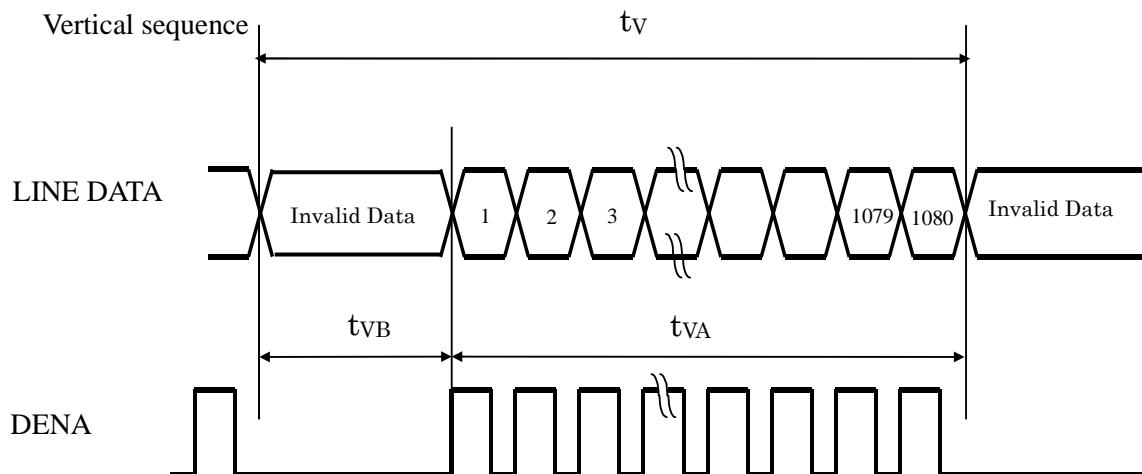

(2) Timing Chart

ITEM		SYMBOL	MIN	TYP	MAX	UNIT		
LCD Timing	Frame Rate		-	60	60	60	Hz	
	DCLK	Frequency	f_{CLK}	70.54	74.25	77.97	MHz	
		Period	t_{CLK}	14.17	13.47	12.82	ns	
	DENA	Horizontal	Horizontal Total time	t_H	1050	1100	1150	tCLK
			Horizontal Active time	t_{HA}	960	960	960	tCLK
			Horizontal Blank time	t_{HB}	90	140	190	tCLK
		Vertical	Vertical Total time	t_V	1120	1125	1130	tH
			Vertical Active time	t_{VA}	1080	1080	1080	tH
			Vertical Blank time	t_{VB}	40	45	50	tH
	LVDS Spread Spectrum Range *3)				-2		2	%

【Note】

- *1) DENA (DATA ENABLE) usually is positive.
- *2) During the whole blank period, DCLK should keep input.
- *3) LVDS input clock is 85MHz and modulation rate is fixed 100KHz

(3) DATA mapping

COLOR	INPUT DATA	R DATA								G DATA								B DATA							
		R7	R6	R5	R4	R3	R2	R1	R0	G7	G6	G5	G4	G3	G2	G1	G0	B7	B6	B5	B4	B3	B2	B1	B0
		MSB							LSB	MSB							LSB	MSB							LSB
BASIC COLOR	BLACK	0	0	0	0	0	0	0	0	0	0	0	0	0	0	0	0	0	0	0	0	0	0	0	0
	RED(255)	1	1	1	1	1	1	1	1	0	0	0	0	0	0	0	0	0	0	0	0	0	0	0	0
	GREEN(255)	0	0	0	0	0	0	0	0	1	1	1	1	1	1	1	1	0	0	0	0	0	0	0	0
	BLUE(255)	0	0	0	0	0	0	0	0	0	0	0	0	0	0	0	0	1	1	1	1	1	1	1	1
	CYAN	0	0	0	0	0	0	0	0	1	1	1	1	1	1	1	1	1	1	1	1	1	1	1	1
	MAGENTA	1	1	1	1	1	1	1	1	0	0	0	0	0	0	0	0	1	1	1	1	1	1	1	1
	YELLOW	1	1	1	1	1	1	1	1	1	1	1	1	1	1	1	1	0	0	0	0	0	0	0	0
	WHITE	1	1	1	1	1	1	1	1	1	1	1	1	1	1	1	1	1	1	1	1	1	1	1	1
RED	RED(0)	0	0	0	0	0	0	0	0	0	0	0	0	0	0	0	0	0	0	0	0	0	0	0	0
	RED(1)	0	0	0	0	0	0	0	1	0	0	0	0	0	0	0	0	0	0	0	0	0	0	0	0
	RED(2)	0	0	0	0	0	0	1	0	0	0	0	0	0	0	0	0	0	0	0	0	0	0	0	0
	RED(254)	1	1	1	1	1	1	1	0	0	0	0	0	0	0	0	0	0	0	0	0	0	0	0	0
	RED(255)	1	1	1	1	1	1	1	1	0	0	0	0	0	0	0	0	0	0	0	0	0	0	0	0
GREEN	GREEN(0)	0	0	0	0	0	0	0	0	0	0	0	0	0	0	0	0	0	0	0	0	0	0	0	0
	GREEN(1)	0	0	0	0	0	0	0	0	0	0	0	0	0	0	1	0	0	0	0	0	0	0	0	0
	GREEN(2)	0	0	0	0	0	0	0	0	0	0	0	0	0	1	0	0	0	0	0	0	0	0	0	0
	GREEN(254)	0	0	0	0	0	0	0	0	1	1	1	1	1	1	0	0	0	0	0	0	0	0	0	0
	GREEN(255)	0	0	0	0	0	0	0	0	1	1	1	1	1	1	1	0	0	0	0	0	0	0	0	0
BLUE	BLUE(0)	0	0	0	0	0	0	0	0	0	0	0	0	0	0	0	0	0	0	0	0	0	0	0	0
	BLUE(1)	0	0	0	0	0	0	0	0	0	0	0	0	0	0	0	0	0	0	0	0	0	0	0	1
	BLUE(2)	0	0	0	0	0	0	0	0	0	0	0	0	0	0	0	0	0	0	0	0	0	0	1	0
	BLUE(254)	0	0	0	0	0	0	0	0	0	0	0	0	0	0	0	1	1	1	1	1	1	1	1	0
	BLUE(255)	0	0	0	0	0	0	0	0	0	0	0	0	0	0	0	1	1	1	1	1	1	1	1	1

【Note】

1) Gray level:

Color(n) : n is level order; higher n means brighter level.

2) DATA:

1: high , 0: low

6. BLOCK DIAGRAM

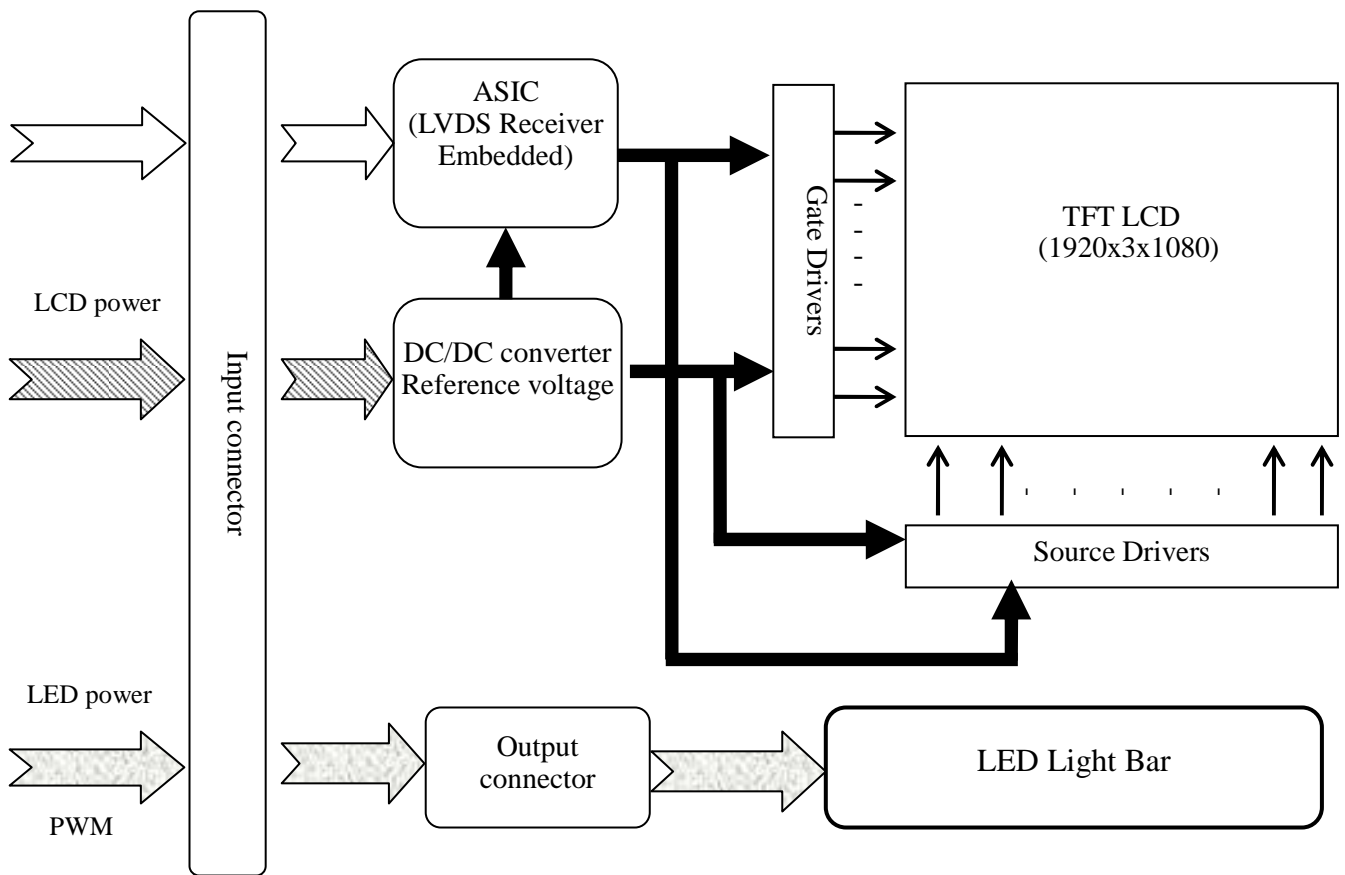

7. MECHANICAL SPECIFICATION

(1) Front side

The tolerance, not show in the figure, is ± 0.5 mm.

[Unit : mm]

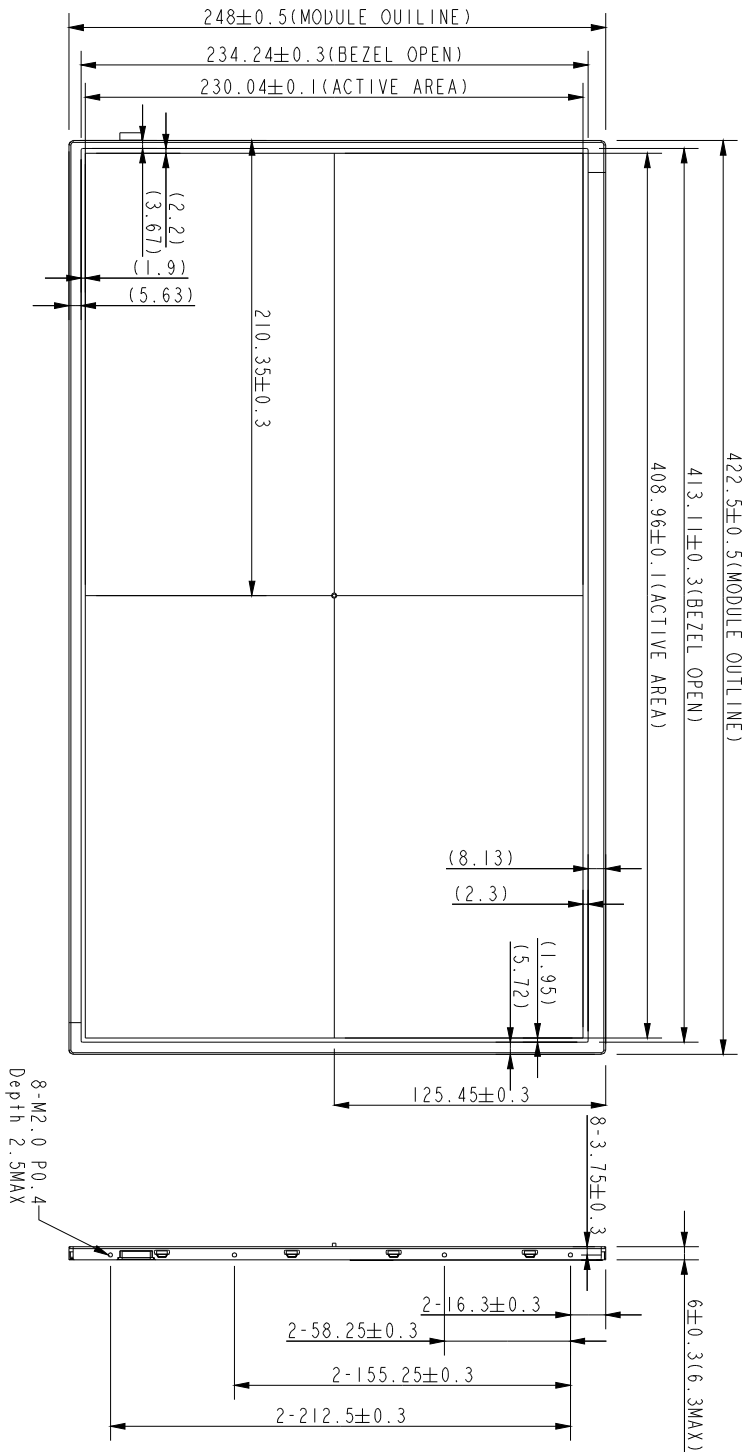

8. OPTICAL CHARACTERISTICS

Ta=25°C , VDD=3.3V

ITEM	SYMBOL	CONDITION	MIN	TYP	MAX	UNIT	NOTE	
Contrast Ratio	CR	$\theta = \psi = 0^\circ$	600	800		--	*1) 2)	
Luminance (CENTER)	L	$\theta = \psi = 0^\circ$	300	350		cd/m ²	*1) 3)	
Uniformity(5P)	ΔL	$\theta = \psi = 0^\circ$	80			%	*1) 3)	
Uniformity(13P)	ΔL	$\theta = \psi = 0^\circ$	65			%	*1) 3)	
Response Time	Tr	$\theta = \psi = 0^\circ$		40	50	ms	*5)	
	Tf	$\theta = \psi = 0^\circ$				ms	*5)	
Cross Talk	CT	$\theta = \psi = 0^\circ$			1	%	*6)	
View Angle	Horizontal	ψ	CR \geq 10	80/-80	89/-89		°	*4)
	Vertical	θ		80/-80	89/-89		°	*4)
Color Coordinate	W	x	$\theta = \psi = 0^\circ$	0.283	0.313	0.343	Color Coordinates	*3)
		y		0.299	0.329	0.359		
	R	x		0.545	0.595	0.645		
		y		0.290	0.340	0.390		
	G	x		0.267	0.317	0.367		
		y		0.563	0.613	0.663		
	B	x		0.106	0.156	0.206		
		y		0.049	0.099	0.149		
Gamut		$\theta = \psi = 0^\circ$	54	60		%		
Gamma	γ	GL	2.0	2.2	2.4		*7)	
Image Sticking	Tis	15 min			5	sec	*8)	

Color coordinate and color gamut are measured by SRUL1R, response time is measured by TRD-100, and all the other items are measured by BM-5A (TOPCON). All these items are measured under the dark room condition (no ambient light).

Measurement Condition: IL= 20mA (each LED)

Definition of these measurement items is as follows:

*1) Setup of Measurement Equipment

The LCD module should be turn-on to a stable luminance level to be reached. The measurement should be executed after lighting Backlight for 20 minutes and in a dark room.

***2) Definition of Contrast Ratio**

CR=ON (White) Luminance/OFF (Black) Luminance

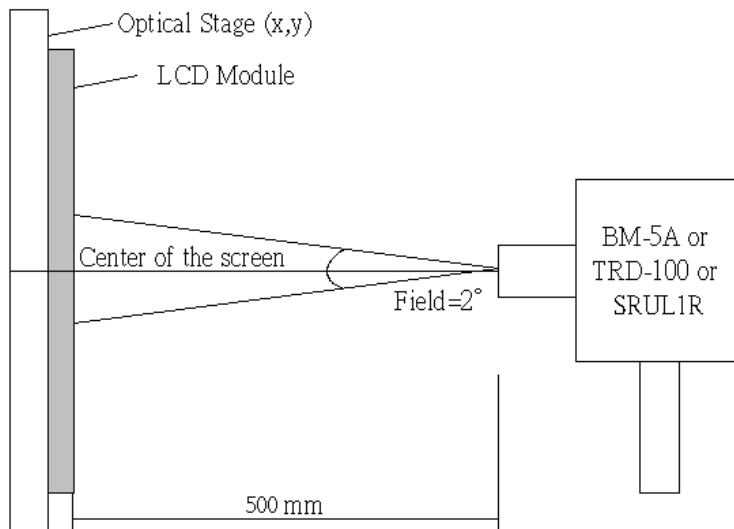

***3) Definition of Luminance and Luminance uniformity**

Central luminance: The white luminance is measured at the center position "5" on the screen, see Fig.1 below.

5P(5,10,11,12,13) Uniformity: $\Delta L = (L_{min} / L_{max}) \times 100\%$

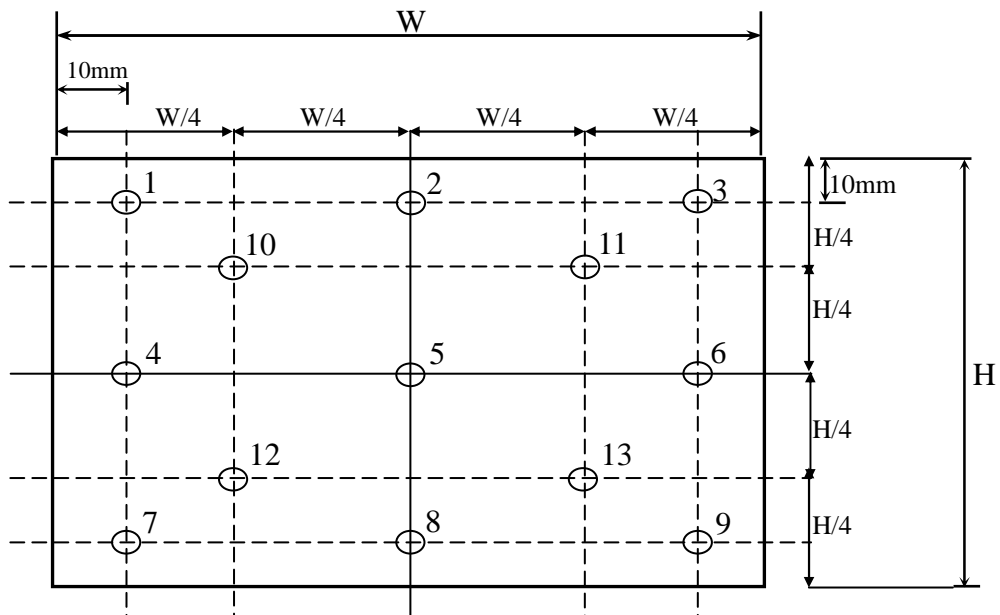
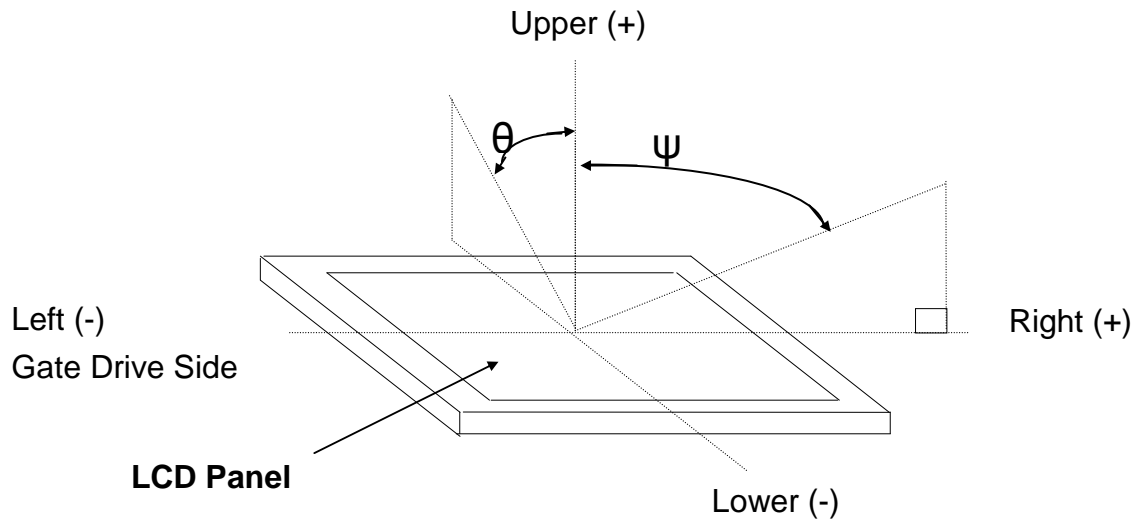
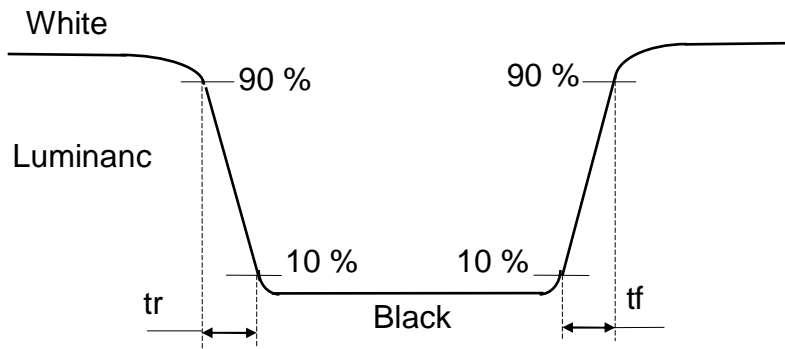

Fig.1 Measure point (Active area)

***4) Definition of view angle(θ , ψ)**



***5) Definition of response time**



***6) Crosstalk Modulation Ratio**

$$CT = | Y_B - Y_A | / Y_{A \times} \times 100\%$$

Y_A 、 Y_B measure position and definition

Y_A means luminance at gray level 31(exclude gray level 0 pattern)

Y_B means luminance at gray level 31(include gray level 0 pattern)

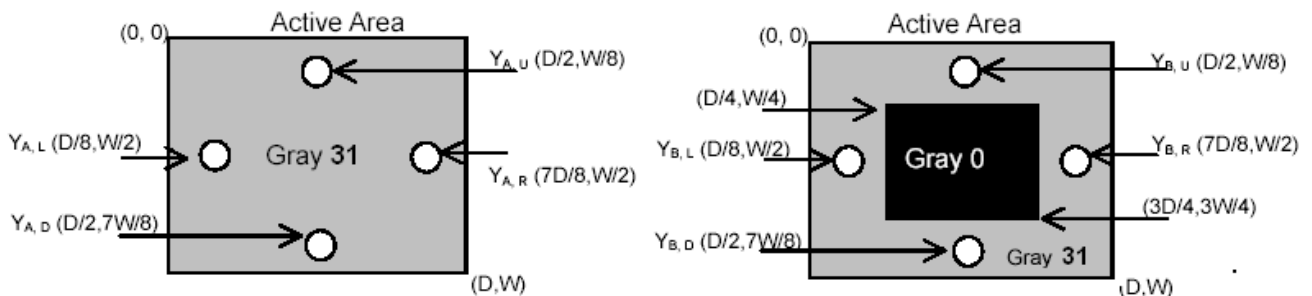

***7) Definition of Gamma (VESA)**

Based on Customer Sample, take the average value as a standard center value and the variation range of gamma value caused by loop voltage error should be between +/- 0.2. the bellow figure shows how to obtain the gamma curve and γ (from gray level: 0、4、8-----60、63).

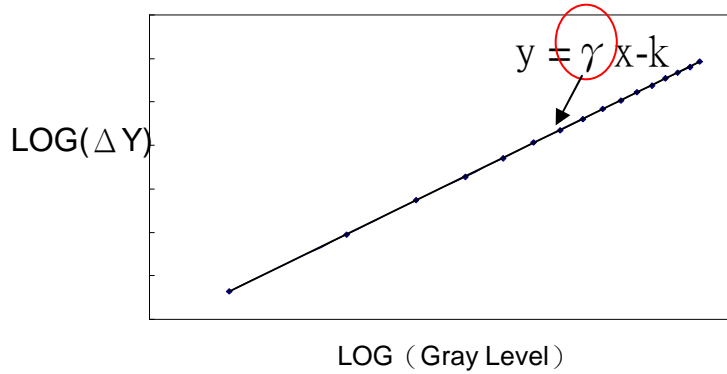

***8) Definition of image sticking**

Continuously display the test pattern shown in the figure below for 30mins. At 25°C.

To change the picture to gray pattern (gray 31 pattern), and the previous image shall not persist during 2 secs.

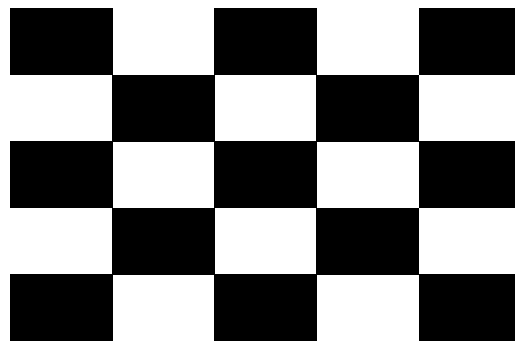

White : 63 Gray
 Black : 0 Gray

9. RELIABILITY TEST CONDITIONS

(1) Temperature and Humidity

TEST ITEMS	CONDITIONS
High Temperature Operation	50° C ; 240Hrs
High Temperature Storage	60° C ; 240Hrs
High Temperature High Humidity Operation	40° C ; 90% RH ; 240Hrs
High Temperature High Humidity Storage	60° C ; 90% RH ; 48 Hrs
Low Temperature Operation	0° C ; 240 Hrs
Low Temperature Storage	-20° C ; 240 Hrs
Thermal Shock	-20° C (0.5 Hr)~60° C (0.5 Hr), Ramp<20° C , 100 CYCLES
Low Temperature Low Pressure storage	0° C 、 260hPa 、 24 Hrs

(2) Shock & Vibration

TEST ITEMS	CONDITIONS
Shock (Non-Operation)	210G, 2ms, half sin wave, ± X,± Y,± Z 1time each
Vibration (Non-Operation)	Random 1.5G, 5~500Hz, 0.5oct/min,each X·Y·Z axis: 60mins (total 180mins)

(3) ESD

	Surface discharge(Panel display area·Frame·PWB·Panel back side)		Electrics capacity of Connector
	Contact	Air	Contact
Capacity	150 pF	150 pF	200 pF
Resistance	330 Ω	330 Ω	0 Ω
Voltage	±8kV	±15kV	±250 V
Interval	1 sec	1 sec	1 sec
Times(single point)	25	25	1

APPENDIX-1: Label Information:

