



Chunghwa Picture Tubes, Ltd.

Technical Specification

To : **Diboss Co., LTD.**

Date : 2006/11/21

CPT TFT-LCD

CLAA201VA07 C

ACCEPTED BY :

APPROVED BY	CHECKED BY	PREPARED BY
		TFT-LCD Product Planning Management General Division

Product Planning management General Division

CHUNGHWA PICTURE TUBES, LTD.

1127 Hopin Rd., Padeh, Taoyuan, Taiwan 334, R.O.C.

TEL: +886-3-3675151 FAX: +886-3-377-3001

Doc.No:	CPT-CLAA201VA07C-Tentative-Ver1.0-2006/11/21	Issue Date:	2006/11/21
---------	--	-------------	------------

T- 3650002- 000- A NEW

RECORD OF REVISIONS

Version	Page	Description	Date
1.0	--	The first edition issued.	2006/10/17

CONTENTS

1.OVERVIEW	3
2. ABSOLUTE MAXIMUM RATINGS	4
3. ELECTRICAL CHARACTERISTICS	5
3.1 TFT-LCD	
3.2 Backlight	
4. INTERFACE PIN CONNECTION	8
4.1 CN1 (TFT-LCD Signal)	
4.2 CN2~7 (Backlight)	
5. INTERFACE TIMING(DE only mode)	9
5.1 Timing Specification	
5.2 Timing Chart	
5.3 Color data assignment	
6. BLOCK DIAGRAM	11
6.1 TFT LCD Module	
7. MECHANICAL SPECIFICATION	12
7.1 Front side	
7.2 Rear side	
8.OPTICAL CHARACTERISTICS	14
9.RELIABILITY TEST CONDITIONS	16
9.1 Temperature and Humidity	
9.2 Shock & Vibration	
9.3 Judgment standard	
10. HANDLING PRECAUTIONS FOR TFT-LCD MODULE	17
10.1 Assembly Precautions	
10.2 Operating Precautions	
10.3 Precautions With Electrostatics	
10.4 Storage Precautions	
10.5 Safety Precautions	
10.6 Others	

1. OVERVIEW

CLAA201VA07C is 20.1" color TFT-LCD (Thin Film Transistor Liquid Crystal Display) module composed of LCD Panel, Driver ICs, and Backlight. By applying 6 bit + FRC digital data, 640 *480, 16.2M-color images are displayed on the 20.1" diagonal screen. Input power voltage is 5.0V for driving LCD module. General specifications are summarized in the following table:

ITEM	SPECIFICATION
Display Area(mm)	408.0 (H) × 306.0 (V) (20.1 inch diagonal)
Number of Pixels	640×3 (H) × 480 (V)
Pixel Pitch(mm)	0.6375 (H) × 0.6375 (V)
Color Pixel Arrangement	RGB vertical strip
Display Mode	Normally White, TN
Number of Colors	16.2M (6bit + FRC)
Brightness(cd/m ²)	450 (cd/m ²) @6.5mA
Response Time	8ms
Viewing Angle (CR ≥ 10)	-80~80(H), 65~70(V)
Wide Viewing Angle Technology	Super Wide View Film
Surface Treatment	Hard coating: 3H; Anti-glare
Electrical Interface	1CH -TTL interface
Total Module Power(W)	33.7W (Typ), BL 32W, Circuit 1.7W
Module Size(mm)	448.0(W) × 347.0(H) × 23.0(Max)(D)
Module Weight(g)	3800 (Typ.)
Backlight Unit	6 CCFLs Side-Lighting

The LCD Products listed on this document are not suitable for use of aerospace equipment, submarine cables, nuclear reactor control system and life support systems. If customers intend to use these LCD products for above application or not listed in "Standard" as follows, please contact with our sales person in advance.

Standard: Computer, Office equipment, Communication equipment, Test and Measurement equipment, Machine tool, Industrial robot, Audio & Visual equipment, and other consumer products.

2. ABSOLUTE MAXIMUM RATINGS

ITEM	SYMBOL	MIN.	MAX.	UNIT	REMARK
Power Supply Voltage For LCD	VCC	-0.3	6	V	
ESD	VESD _c	-250	250	V	*1)
	VESD _m	-15K	15K	V	
Lamp Current	IL	2.0	6.5	mArms	
Lamp Frequency	FL	40	80	kHz	
Operation Temperature	T _{op}	0	50	°C	
Storage Temperature	T _{stg}	-20	60	°C	

[Note]

*1) The test condition is base on IEC 1000-4-2.

VESD_c: Discharge to Input-Connector; VESD_m: Discharge to Module

3. ELECTRICAL CHARACTERISTICS

3.1 TFT-LCD

Ta=25°C

ITEM	SYMBOL	MIN	TYP	MAX	UNIT	REMARK
Power Supply Voltage For LCD	VCC	4.5	5.0	5.5	V	*1)
Rush Current For LCD	Irush	--	--	2	A	*2)
Power Supply Current For LCD	ICC	--	300	500	mA	*3)
Permissible Ripple Voltage	VRP	--	--	100	mVp-p	VCC=5.0V
Logic Input Voltage	High	VIH	3.0	3.3	V	
	Low	VIL	0	--	0.5	V

[Note]

*1) Power And Signal Sequence

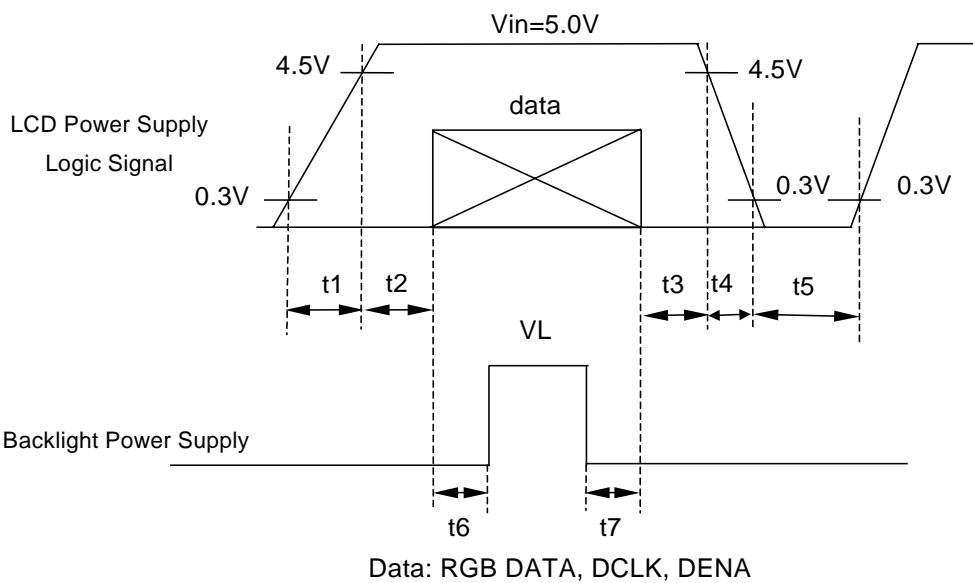

- 0.5ms <math>< t1 \leq 10ms</math> 500ms $\leq t5$
- 0 <math>< t2 \leq 50ms</math> 200ms $\leq t6$
- 0 <math>< t3 \leq 50ms</math> 200ms $\leq t7$
- 0 <math>< t4 \leq 10ms</math>

*2) The system of measure Input Rush Current as below.

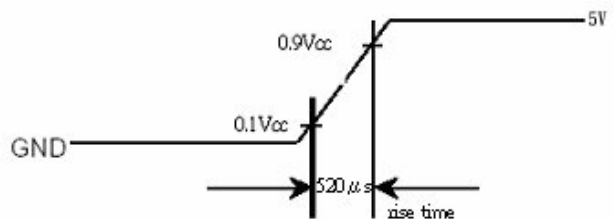
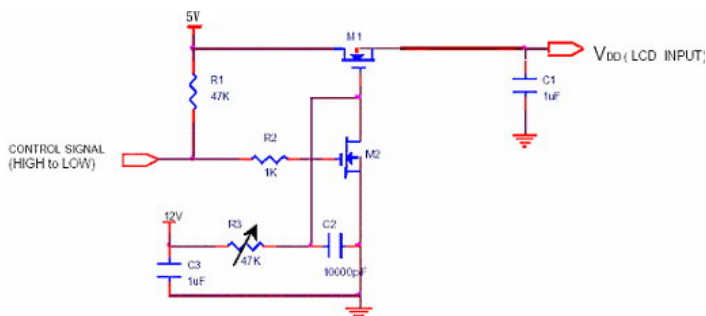

*3) Power Supply Current For LCD

Test Conditional: $V_{CC}=5.0\text{ V}$, $f_H=31.5\text{ kHz}$, $f_V=60\text{ Hz}$, $f_{CLK}=25\text{ MHz}$

Test pattern: (a) 256 gray level (b) 2*1 pixel

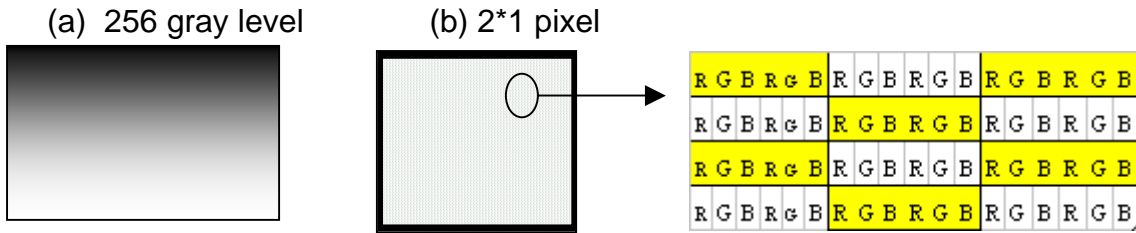

3.2 BACKLIGHT

$T_a=25^\circ\text{C}$

ITEM	SYMBOL	MIN	TYP	MAX	UNIT	REMARK
Lamp Voltage	VL	--	790	--	Vrms	IL=6.5mA
Lamp Current	IL	2.0	6.5	6.5	mArms	*1)
Inverter Frequency	FI	50	55	60	kHz	*2)
Starting Lamp Voltage	VS	--	--	1670	Vrms	$T_a= 0^\circ\text{C}$
		--	--	1500	Vrms	$T_a= 25^\circ\text{C}$
Lamp life Time	LT	40,000	--	--	hr	*3) IL=6.5mA Continuous Operation

[Note]

If the driving waveform of lamp is asymmetric, the distribution of mercury inside the lamp tube will become unequally or will deplete the Ar gas in it. Then it may cause the abnormal phenomenon when lighting the lamp up. Therefore, designers have to try their best to for fill the conditions under the inverter designing-stage as below:

The degrees of unbalance: less than 10%
 The ratio of wave height: less than $\sqrt{2} \pm 10\%$

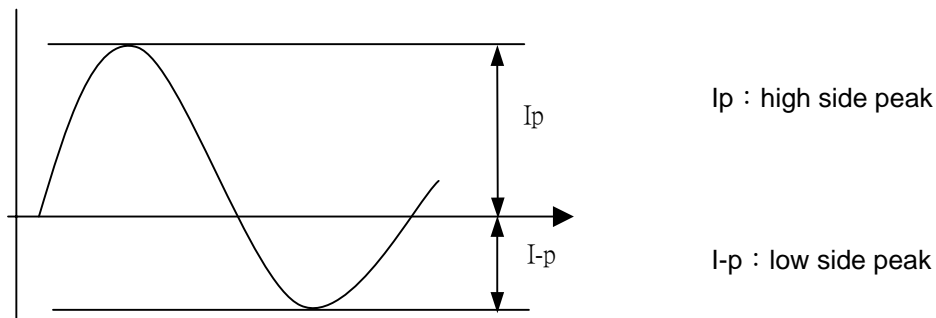

A: The degrees of unbalance = $| I_p - I-p | / I_{rms} \times 100 (\%)$

B: The ratio of wave height = $I_p \text{ (or } I-p) / I_{rms}$

And need feedback for safe of protection hypothesis

*1) Measurement Method of Lamp Current (the current meter is inserted in low voltage line)

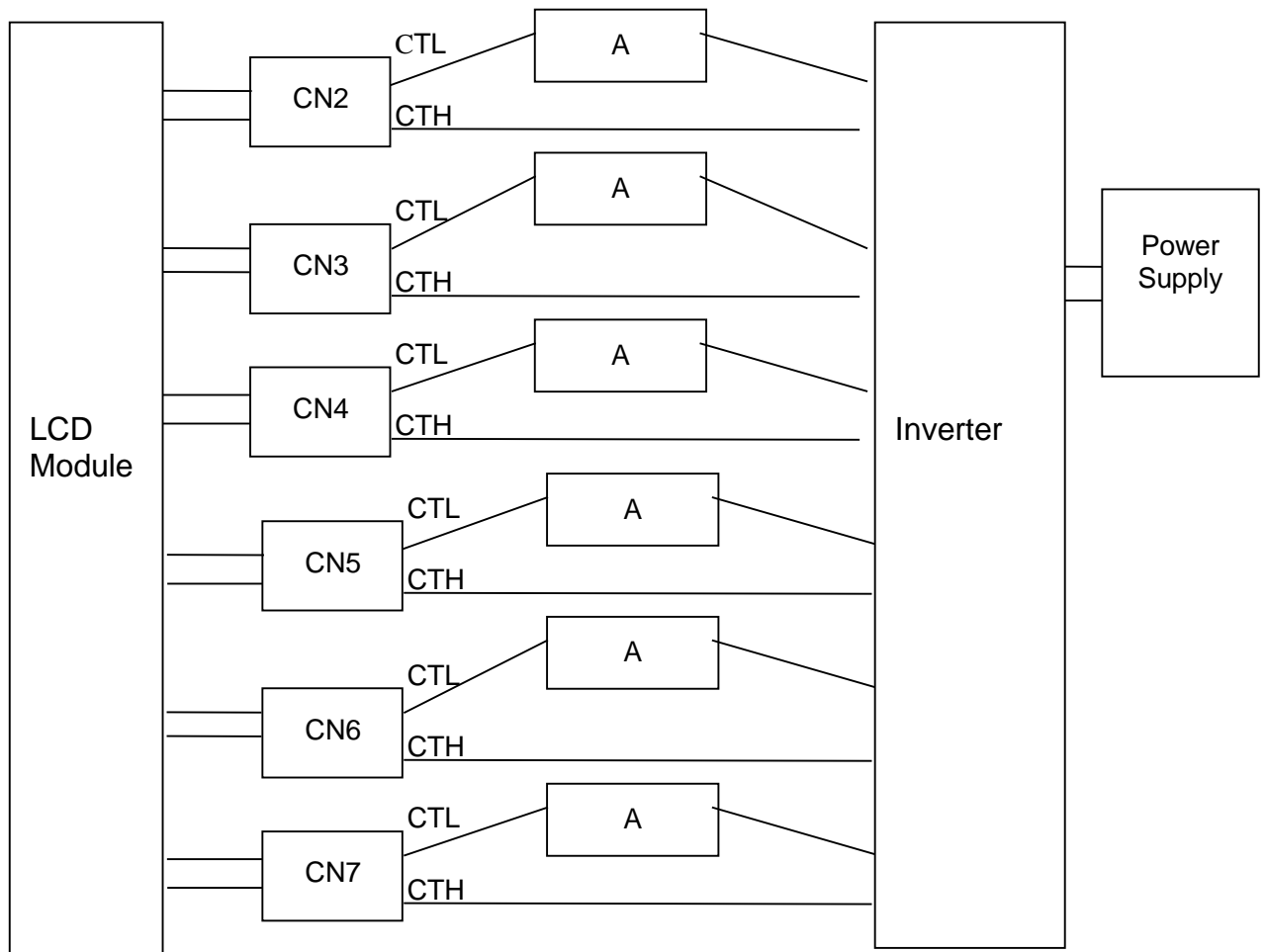

*2) The influence of lamp frequency

This frequency range can keep the electrical and optical character within $\pm 10\%$ variation. Lamp frequency may interfere with horizontal synchronous frequency (or vertical synchronous frequency), and then cause ripple noise on the display. Therefore, please adjust the frequency of lamp input, be removed inverter from module as possible, or use electronic shielding between inverter and module to avoid the interference.

*3) Definition of the lamp life: the luminance reduced to 50% of initial value.

*4) Definition of lamp(center) wire color: the lamp(center) wire color shown as below:

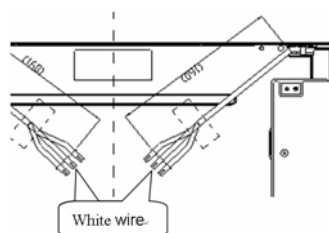

4. INTERFACE PIN CONNECTION

4.1 CN1 (TFT-LCD Signal)

Used connector: AF7506-N2G11

Number	Symbol	Function
1	TEST	Should be open during operation (Internal test only)
2	TEST	Should be open during operation (Internal test only)
3	TEST	Should be open during operation (Internal test only)
4	GND	Ground
5	GND	Ground
6	VCC	5V
7	VCC	5V
8	VCC	5V
9	VCC	5V
10	GND	Ground
11	HD	Horizontal sync
12	VD	Vertical sync
13	GND	Ground
14	DENA	Data Enable
15	GND	GND
16	CLK	Dot Clock
17	GND	Ground
18	R7	Red data (MSB)
19	R6	Red data
20	R5	Red data
21	R4	Red data
22	GND	Ground
23	R3	Red data
24	R2	Red data
25	R1	Red data
26	R0	Red data
27	GND	Ground
28	G7	Green data
29	G6	Green data
30	G5	Green data
31	G4	Green data
32	GND	Ground
33	G3	Green data
34	G2	Green data
35	G1	Green data
36	G0	Green data
37	GND	Ground
38	B7	Blue data
39	B6	Blue data
40	B5	Blue data
41	B4	Blue data
42	GND	Ground
43	B3	Blue data
44	B2	Blue data
45	B1	Blue data
46	B0	Blue data (LSB)
47	GND	Ground
48	GND	Ground
49	NC	NC
50	NC	NC

4.2 CN2~7 (Backlight)

Backlight-side connector CN2,3,4,5,6,7: BHSR-02VS-1(JST)
 Inverter-side connector: SM02B-BHSS-1(JST)

Pin No.	Symbol	Function
1	CTH	VLH (High voltage)
2	CTL	VL (Low voltage)

[Note] VLH-VL=VL

5. INTERFACE TIMING

5.1 TIMING SPECIFICATION

	ITEM	SYMBOL	MIN	TYP	MAX	UNIT	Note
Clock	Frequency	1/Tclk	20	25	30.5	MHz	
	Frame Rate	Fr	50	60	72	Hz	
Vertical Section	Vertical Total	Tv	495	525	570	Th	Tv= Tvd+ Tvb
	Vertical Valid	Tvd	480	480	480	Th	
	Vertical Blank	Tvb	15	45	90	Th	
Horizontal Section	Horizontal Total	Th	718	800	850	Tclk	Th= Thd+ Thb
	Horizontal Valid	Thd	640	640	640	Tclk	
	Horizontal Blank	Thb	78	160	210	Tclk	

[Note] This module is operated by DE only mode.

5.2 TIMING CHART

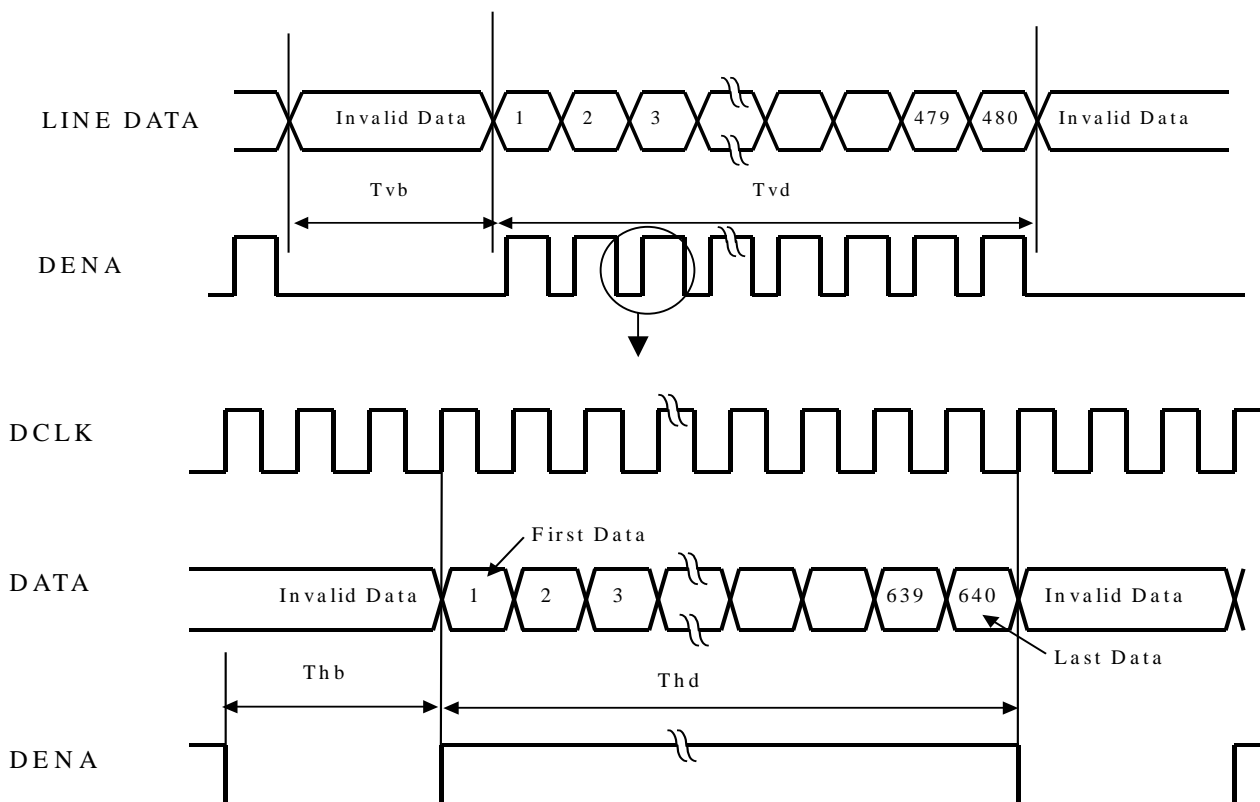

5.3 COLOR DATA ASSIGNMENT

COLOR	INPUT DATA	R DATA								G DATA								B DATA							
		R7	R6	R5	R4	R3	R2	R1	R0	G7	G6	G5	G4	G3	G2	G1	G0	B7	B6	B5	B4	B3	B2	B1	B0
		MSB				LSB				MSB				LSB				MSB				LSB			
BASIC COLOR	BLACK	0	0	0	0	0	0	0	0	0	0	0	0	0	0	0	0	0	0	0	0	0	0	0	0
	RED(255)	1	1	1	1	1	1	1	1	0	0	0	0	0	0	0	0	0	0	0	0	0	0	0	
	GREEN(255)	0	0	0	0	0	0	0	0	1	1	1	1	1	1	1	0	0	0	0	0	0	0	0	
	BLUE(255)	0	0	0	0	0	0	0	0	0	0	0	0	0	0	0	1	1	1	1	1	1	1	1	
	CYAN	0	0	0	0	0	0	0	0	1	1	1	1	1	1	1	1	1	1	1	1	1	1	1	
	MAGENTA	1	1	1	1	1	1	1	1	0	0	0	0	0	0	0	1	1	1	1	1	1	1	1	
	YELLOW	1	1	1	1	1	1	1	1	1	1	1	1	1	1	1	0	0	0	0	0	0	0	0	
	WHITE	1	1	1	1	1	1	1	1	1	1	1	1	1	1	1	1	1	1	1	1	1	1	1	
RED	RED(0)	0	0	0	0	0	0	0	0	0	0	0	0	0	0	0	0	0	0	0	0	0	0	0	
	RED(1)	0	0	0	0	0	0	0	1	0	0	0	0	0	0	0	0	0	0	0	0	0	0	0	
	RED(2)	0	0	0	0	0	0	1	0	0	0	0	0	0	0	0	0	0	0	0	0	0	0	0	
	RED(254)	1	1	1	1	1	1	1	0	0	0	0	0	0	0	0	0	0	0	0	0	0	0	0	
	RED(255)	1	1	1	1	1	1	1	1	0	0	0	0	0	0	0	0	0	0	0	0	0	0	0	
GREEN	GREEN(0)	0	0	0	0	0	0	0	0	0	0	0	0	0	0	0	0	0	0	0	0	0	0	0	
	GREEN(1)	0	0	0	0	0	0	0	0	0	0	0	0	0	0	1	0	0	0	0	0	0	0	0	
	GREEN(2)	0	0	0	0	0	0	0	0	0	0	0	0	0	0	1	0	0	0	0	0	0	0	0	
	GREEN(254)	0	0	0	0	0	0	0	0	1	1	1	1	1	1	0	0	0	0	0	0	0	0	0	
	GREEN(255)	0	0	0	0	0	0	0	0	1	1	1	1	1	1	1	0	0	0	0	0	0	0	0	
BLUE	BLUE(0)	0	0	0	0	0	0	0	0	0	0	0	0	0	0	0	0	0	0	0	0	0	0	0	
	BLUE(1)	0	0	0	0	0	0	0	0	0	0	0	0	0	0	0	0	0	0	0	0	0	0	1	
	BLUE(2)	0	0	0	0	0	0	0	0	0	0	0	0	0	0	0	0	0	0	0	0	0	1	0	
	BLUE(254)	0	0	0	0	0	0	0	0	0	0	0	0	0	0	0	1	1	1	1	1	1	1	0	
	BLUE(255)	0	0	0	0	0	0	0	0	0	0	0	0	0	0	0	1	1	1	1	1	1	1	1	

[Note]

- 1) Definition of gray scale:
Color(n): "n" indicates gray scale level.
Higher "n" means brighter level.
- 2) Data:1-High,0-Low.
- 3) This assignment is applied to both odd and even data.

(d) DATA MAPPING

D(1, 1)	D(2, 1)	---	D(X, 1)	---	D(639, 1)	D(640, 1)
D(1, 2)	D(2, 2)	---	D(X, 2)	---	D(639, 2)	D(640, 2)
		+		+		
D(1, Y)	D(2, Y)	---	D(X, Y)	---	D(639, Y)	D(640, Y)
		+		+		
D(1,479)	D(2,479)	---	D(X,479)	---	D(639,479)	D(640,479)
D(1,480)	D(2,480)	---	D(X,480)	---	D(639,480)	D(640,480)

6. BLOCK DIAGRAM

6.1 TFT-LCD MODEL

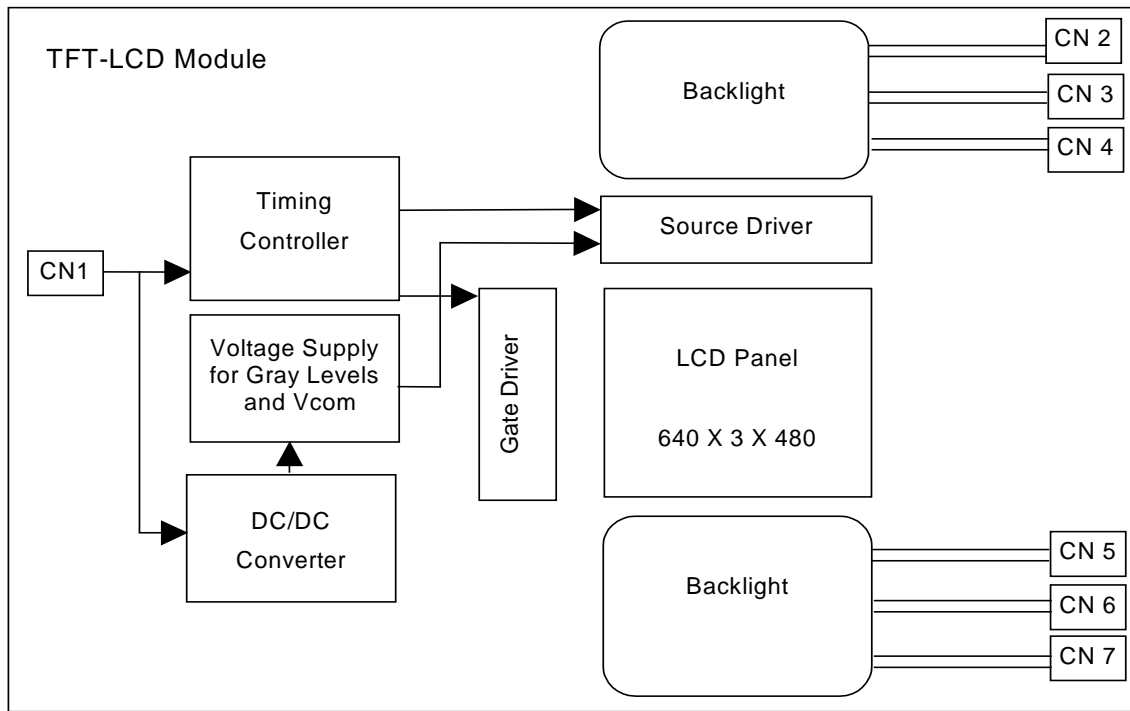

BACKLIGHT

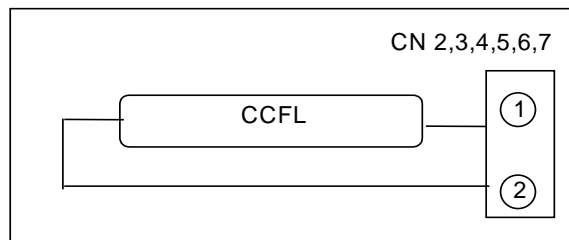

7. MECHANICAL SPECIFICATION

7.1 FRONT SIDE (Tolerance is ± 0.5mm unless noted)

Unit: mm

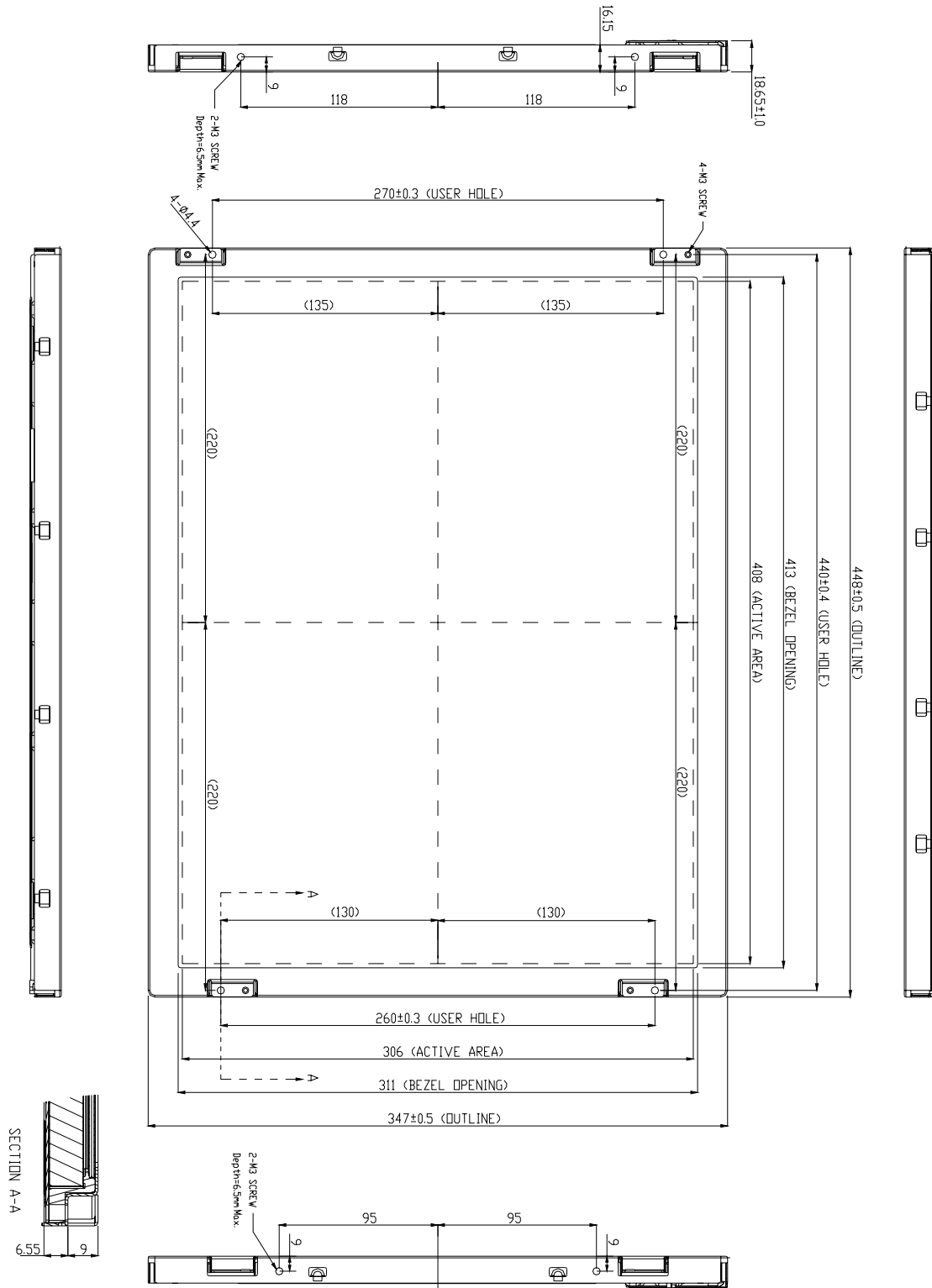

7.2 REAR SIDE

Unit: mm

1. Tolerance is $\pm 0.5\text{mm}$ unless noted.
2. The length of lamp wire(A) is $160\pm 15\text{mm}$.

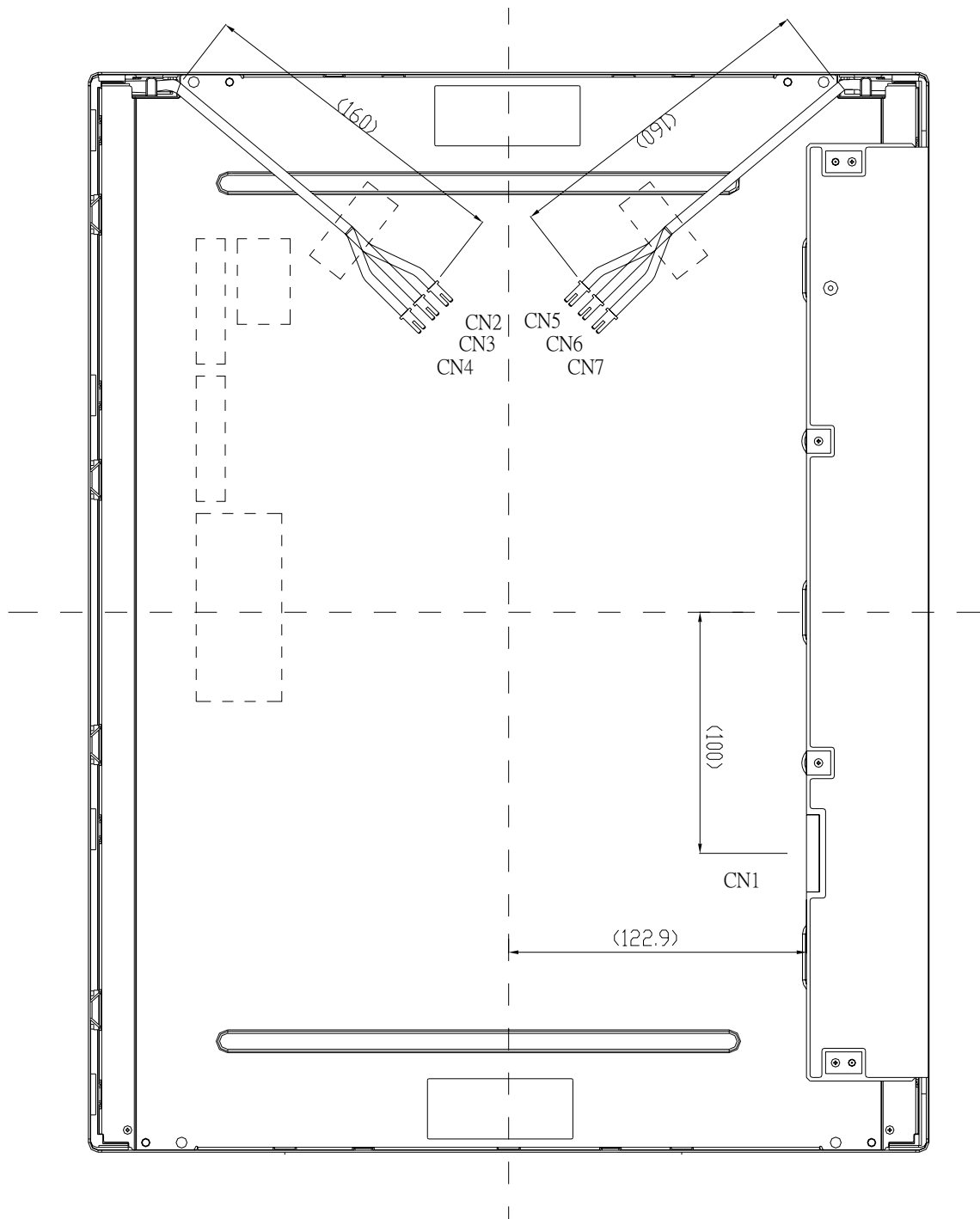

8. OPTICAL CHARACTERISTICS

Ta=25°C, VCC=5.0V

ITEM	SYMBOL	CONDITION	MIN.	TYP.	MAX.	UNIT	Remark
Contrast Ratio	CR	$\theta = \phi = 0^\circ$	450	500	--	--	*1)
Luminance (CEN)	L	$\theta = \phi = 0^\circ$	380	450	--	cd/m ²	*2)
Luminance (CEN)	5P Luminance(AVG)	$\theta = \phi = 0^\circ$	340	400		cd/m ²	*2)
	Uniformity	ΔL	75	--		%	*2)
Response Time	Tr	$\theta = \phi = 0^\circ$	--	3	4	ms	*4)
	Tf	$\theta = \phi = 0^\circ$	--	5	8	ms	*4)
Viewing Angle	Horizontal	$CR \geq 5$	-75~75	-80~80	--	°	*2), *3)
	Vertical		-65~65	-65~70		°	*2), *3)
Color Coordinates	White	x	0.253	0.283	0.313	--	*2), *3)
		y	0.267	0.297	0.327		
	Red	x	0.619	0.649	0.679		
		y	0.297	0.327	0.357		
	Green	x	0.246	0.276	0.306		
		y	0.583	0.613	0.643		
	Blue	x	0.114	0.144	0.174		
		y	0.047	0.077	0.107		

[Note]

These items are measured by BM-5A(TOPCON) and EZ-Contrast in the dark room (no ambient light)

Brightness condition: (IL=6.5 mA)

Inverter: Frequency 55kHz

Definition of these measurement items are as follows:

*1) Definition of Contrast Ratio

$$CR = \text{ON(White)Luminance} / \text{OFF(Black)Luminance}$$

*2) Definition of Luminance and Luminance uniformity:

[These items are measured using BM-5A (TOPCON) under the dark room condition (no ambient light).]

Central luminance: The white luminance is measured at the center position "5" on the screen, see Fig 1 below.

5P Luminance (AVG): The white luminance is measured at measuring points 1, 2, 3, 4, and 5, see Fig 1 below.

$$\text{Uniformity (5 point): } \Delta L = (L_{\text{MIN}} / L_{\text{MAX}}) \times 100\%$$

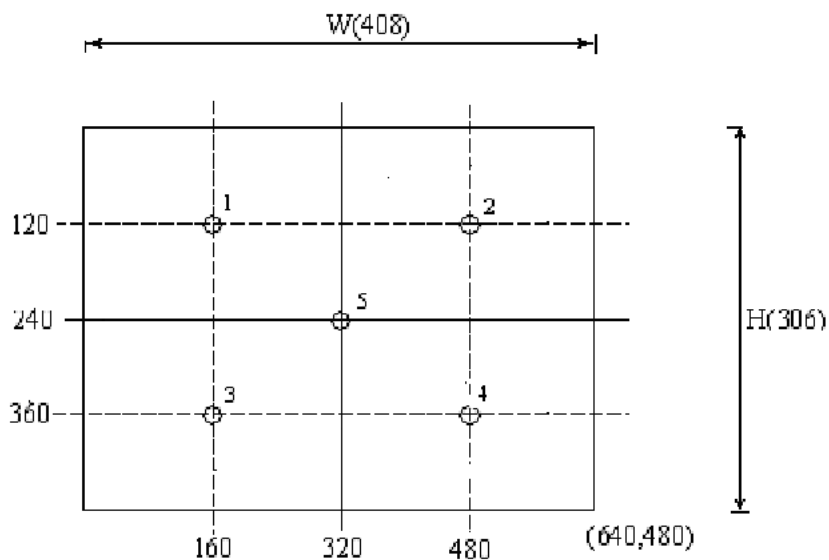

*3) Definition of Viewing Angle (θ, ϕ)

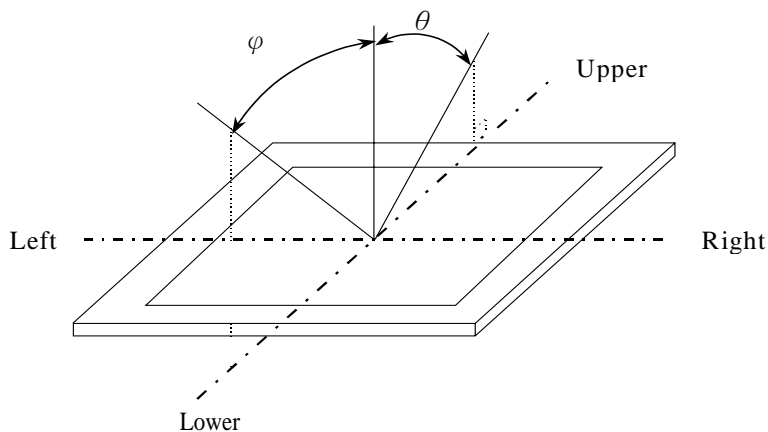

*4) Definition of Response Time (White - Black)

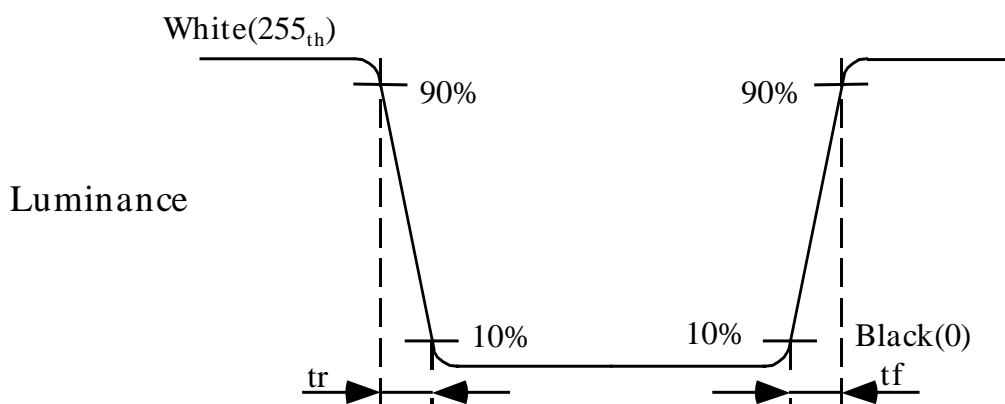

9. RELIABILITY TEST CONDITIONS

9.1 TEMPERATURE AND HUMIDITY

TEST ITEMS	CONDITIONS
High Temperature High Humidity Operation	50°C, 90%RH, 240h (No condensation)
High Temperature High Humidity Storage	60°C, 90% RH, 48h (No condensation)
High Temperature Operation	50°C, 240h
Low Temperature Storage	-20°C, 240h
High Temperature Storage	60°C, 240h
Low Temperature Operation	0°C, 240h

9.2 SHOCK AND VIBRATION

ITEMS	CONDITIONS
SHOCK (NON-OPERATION)	Shock level: 980m/s ² (100G) Waveform: half sinusoidal wave, 2ms Number of shocks: one shock input in each direction of three mutually perpendicular axes for a total of six shock inputs
VIBRATION (NON-OPERATION)	Vibration level: 9.8m/s ² (1.0G) zero to peak Waveform: sinusoidal Frequency range: 5 to 500 Hz Frequency sweep rate: 0.5 octave/min Duration: one sweep from 5 to 500 to 5 Hz in each of three mutually perpendicular axis (each x, y, z axis: 10 min, total 30 mins)

9.3 Judgment standard

The judgment of the above test should be made as follow:

Pass: Normal display image with no obvious non-uniformity and no line defect.

Partial transformation of the module parts should be ignored.

Fail: No display image, obvious non-uniformity, or line defects.

10. HANDLING PRECAUTIONS FOR TFT-LCD MODULE

Please pay attention to the followings in handling TFT-LCD products.

10.1 ASSEMBLY PRECAUTION

- (1) Please use the mounting hole on the module side in installing and do not beading or wrenching LCD in assembling. And please do not drop, bend or twist LCD module in handling.
- (2) Please design display housing in accordance with the following guidelines.
 - Housing case must be destined carefully and do not to put stresses on LCD all sides or wrench module. The stresses may cause non-uniformity even if there is no non-uniformity statically.
 - Keep sufficient clearance between LCD module back surface and housing when the LCD module is mounted. Approximately 1.0 mm of the clearance in the design is recommended taking into account the tolerance of LCD module thickness and mounting structure height on the housing.
 - When some parts, such as, FPC cable and ferrite plate, are installed underneath the LCD module, still sufficient clearance is required, such as 0.5mm. This clearance is, especially, to be reconsidered when the additional parts are implemented for EMI countermeasure.
 - Design the inverter location and connector position carefully so as not to put stress on lamp cable.
 - Keep sufficient clearance between LCD module and the other parts, such as inverter and speaker so as not to interface the LCD module. Approximately 1.0mm of the clearance in the design is recommended.
- (3) Please do not push or scratch LCD panel surface with any-thing hard. And do not soil LCD panel surface by touching with bare hands. (Polarizer film and surface of LCD panel are easy to be flawed.)
- (4) Please do not press any parts on the rear side such as source TCP, gate TCP, control circuit board and FPC during handling the LCD module. If pressing rear part could not be avoided, handle the LCD module with care not to damage them.
- (5) Please wipe out LCD panel surface with absorbent cotton or soft clothe in case of it being soiled.
- (6) Please wipe out drops of adhesives like saliva and water on LCD panel surface immediately. They might damage to cause panel surface variation and color change.
- (7) Please do not take a LCD module to pieces and reconstruct it. Resolving and reconstructing modules may cause them not to work well.
- (8) Please do not touch metal frames with bare hands and soiled gloves. A color change of the metal frames can happen during a long preservation of soiled LCD modules.

- (9) Please pay attention to handling lead wire of backlight so that it is not tugged in connecting with inverter.

10.2 OPERATING PRECAUTIONS

- (1) Please be sure to turn off the power supply before connecting and disconnecting signal input cable.
- (2) Please do not change variable resistance settings in LCD module. They are adjusted to the most suitable value. If they are changed, it might happen LCD does not satisfy the characteristics specification.
- (3) Please consider that LCD backlight takes longer time to become stable of radiation characteristics in low temperature than in room temperature.
- (4) A condensation might happen on the surface and inside of LCD module in case of sudden change of ambient temperature.
- (5) Please pay attention to displaying the same pattern for a very long time. Image might stick on LCD. If then, time going on can make LCD work well.
- (6) Please obey the same caution descriptions as ones that need to pay attention to ordinary electronic parts.

10.3 PRECAUTIONS WITH ELECTROSTATICS

- (1) This LCD module use CMOS-IC on circuit board and TFT-LCD panel, and so it is easy to be affected by electrostatics. Please be careful with electrostatics by the way of your body connecting to the ground and so on.
- (2) Please remove protection film very slowly on the surface of LCD module to prevent from electrostatics occurrence.

10.4 STORAGE PRECAUTIONS

- (1) When you store LCD for a long time, it is recommended to keep the temperature between 0°C ~40°C without the exposure of sunlight and keep the humidity less than 90%RH.
- (2) Please do not leave the LCD in the environment of high humidity and high temperature such as 60°C 90%RH.
- (3) Please do not leave the LCD in the environment of low temperature(can not lower than -20°C).

10.5 SAFETY PRECAUTIONS

- (1) When you waste LCD, it is recommended to crush damaged or unnecessary LCD into pieces and wash them off with solvents such as acetone and ethanol, which should later be burned.
- (2) If any liquid leaks out of a damaged-glass cell and comes in contact with the hands, wash off thoroughly with soap and water.

11.6 OTHERS

- (1) A strong incident light into LCD panel might cause display characteristics' changing inferior because of polarizer film, color filter, and other materials becoming inferior. Please do not expose LCD module direct sunlight and strong UV rays.
- (2) Please pay attention on the side of LCD module do not contact with other materials in preserving it alone.
- (3) For the packaging box, please pay attention to the followings:
 - Packaging box and inner case for LCD are designed to protect the LCD from the damage or scratching during transportation. Please do not open except picking LCD up from the box.
 - Please do not pile them up more than 3 boxes. (They are not designed so.) And please do not turn over.
 - Please handle packaging box with care not to give them sudden shock and vibrations. And also please do not throw them up.
 - Packing box and inner case for LCD are made of cardboard. So please pay attention not to get them wet. (Such as keep them away the high humidity or wet place.)