



# Chunghwa Picture Tubes, Ltd.

## Technical Specification

To : **Kuender**  
Date : 2011.05.18

*CPT TFT-LCD*  
**CLAA 215FA**                      **04**                      **(V4)**

**ACCEPTED BY :**

APPROVED BY	CHECKED BY	PREPARED BY
<b>Kevin Chen</b>	<b>Sean Lee</b>	<b>Product Planning Management General Division</b>

Prepared by : Design General Division

**CHUNGHWA PICTUER TUBES, LTD.**

No. 1, Huaying Rd., Sanho Tsun, Lungtan Shiang, Taoyuan, Taiwan, 325, R.O.C.  
TEL: +886-3-4805678    FAX: +886-3-4800589

Doc. No:	CLAA215FA04_V4-Kuender-SPEC-Ver.1-20110518	Issue Date:	2011/05/18
----------	--	-------------	------------

## 1. OVERVIEW

CLAA215FA04\_V4 is 21.5" color TFT-LCD (Thin Film Transistor Liquid Crystal Display) module composed of LCD panel, driver ICs, control circuit and backlight. By applying 6bits+Hi-FRC digital data, 1920×1080, 16.7M-color images are displayed on the 21.5" diagonal screen. Input power voltage is 5.0V for LCD driving. Converter for backlight is not included in this module. General specification is summarized in the following table:

ITEM	SPECIFICATION
Display Area(mm)	476.64 (H) × 268.11 (V) (21.53-inch diagonal)
Number of Pixels	1920 (H) × 1080(V)
Pixel Pitch(mm)	0.24825 (H) × 0.24825 (V)
Color Pixel Arrangement	RGB vertical stripe
Display Mode	Normally white, TN
Number of Colors	16.7M(6bits+Hi-FRC)
Brightness(cd/m <sup>2</sup> )	250cd/m <sup>2</sup> (Typ.)(center, 60mA)
Viewing Angle(H/V)	170/160 (Typ.)
Surface Treatment	Anti-glare, 3H
Power consumption(W)	17.5W Without Converter(Typ.)
Module Size(mm)	495.6 (W) × 292.2 (H) ×9.85(D) (Typ.)
Module Weight(g)	1730g(Typ.)
Backlight Unit	LED (White-LED)

## 2. ABSOLUTE MAXIMUM RATINGS

ITEM	SYMBOL	MIN.	MAX.	UNIT	REMARK
Power Supply Voltage for LCD	VCC	0	6	V	
LED Forward voltage	V <sub>F</sub>	2.9	3.6	V	1). 2)
LED Forward current	I <sub>F</sub>	57	63	mA	
Operation Temperature	Top	0	50	°C	3). 4). 5). 7)
Storage Temperature	Tstg	-20	60	°C	3). 4). 5). 7)

[Note]

- Product life-time relate to LED, please operate production follow statement at page 8 “(2)back light” .
- When LED current over the definition of operating current ,product life-time will decay rapidly or operate unusual.
- The relative temperature and humidity range are as below sketch, 90%RHMax.(Ta ≤ 40°C).
- The maximum wet bulb temperature ≤ 39°C (Ta > 40°C) and without dewing.
- If you use the product in an environment which over the definition of temperature and humidity too long to effect the result of eye-etching.
- Test Condition: IEC 1000-4-2 VESDt: Contact discharge to input connector; VESDc: Contact discharge to module
- If you operate the product in normal temperature range, the center surface of panel should be under 60°C.

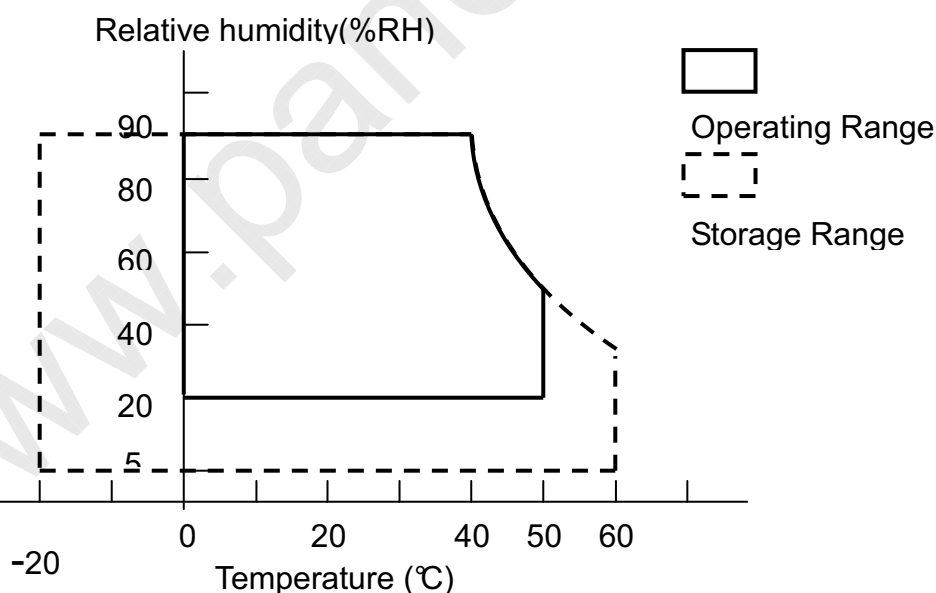

## 3. ELECTRICAL CHARACTERISTICS

## (1).TFT-LCD

Ta=25°C

ITEM	SYMBOL	MIN	TYP	MAX	UNIT	REMARK	
Power Supply Voltage for LCD	VCC	4.5	5.0	5.5	V	*1)	
Power Supply Current for LCD	ICC	--	1050	1950	mA	*2)	
Permissive Ripple Voltage for Logic	VRP	--	--	100	mVp-p	VCC=5.0V	
Differential Resistance	Zm	90	100	110	Ω		
LVDS: IN+ , IN-	The same motion input Voltage	VCM	1.125	1.25	1.375	V	*3)
	Differential input Voltage	VID	350	450	450	mV	
	High electric potential threshold voltage	VTH	-	-	100	mV	
	Low electric potential threshold voltage	VTL	-100	-	-	mV	
LCD Irush Current	Irush	-	-	4	A	*4)	
Power consumption	P	-	5	11	W	*2)	

[Note]

\*1)Power 、 data sequence

$$0.50\text{ms} \leq t1 \leq 10\text{ms}$$

$$t4 \geq 1 \text{ sec}$$

$$0.01\text{ms} < t2 \leq 50\text{ms}$$

$$t5 \geq 200\text{ms}$$

$$0.01\text{ms} < t3 \leq 50\text{ms}$$

$$t6 \geq 200\text{ms}$$

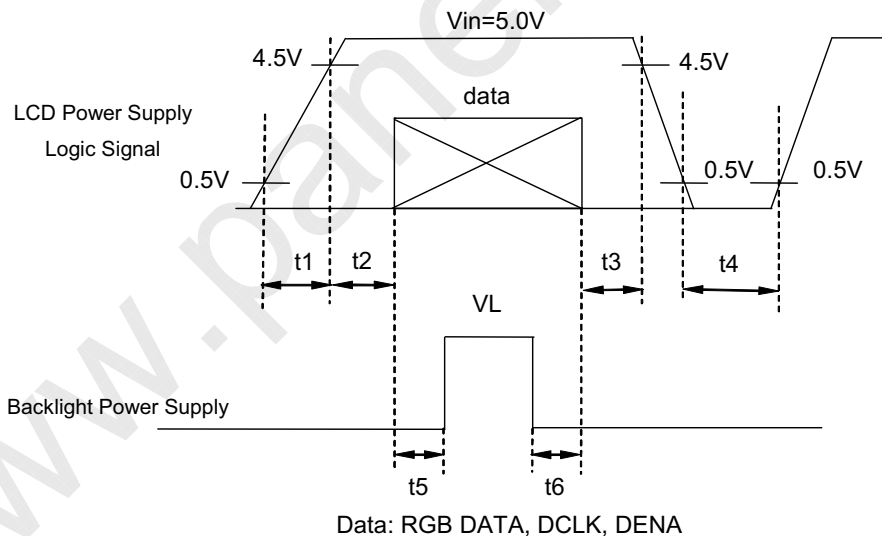

VCC-dip conditions:

- (1) When  $3.6\text{V} \leq V_{cc}(\text{min}) < 4.5\text{V}$ :  $t_d \leq 10\text{ ms}$
- (2) When  $V_{cc} < 3.6\text{ V}$ , VCC-dip conditions should also follow the VCC-turn-on conditions.

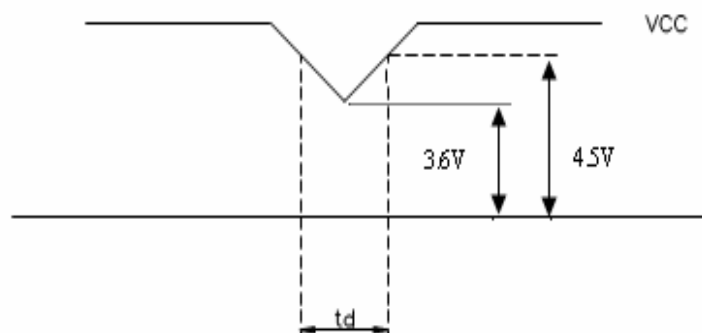

2). Typical value is measured when displaying horizontal gray scale line pattern:

64 gray level, 1920 line mode

$V_{CC}=5.0\text{ V}$ ,  $f_H=67.8\text{ kHz}$ ,  $f_V=60\text{ Hz}$ ,  $f_{CLK}=72\text{ MHz}$

Maximum value is measured when displaying 2 line pattern:

$V_{CC}=5.0\text{ V}$ ,  $f_H=66.9\text{ kHz}$ ,  $f_V=75\text{ Hz}$ ,  $f_{CLK}=90\text{ MHz}$

\*3) LVDS Signal definition

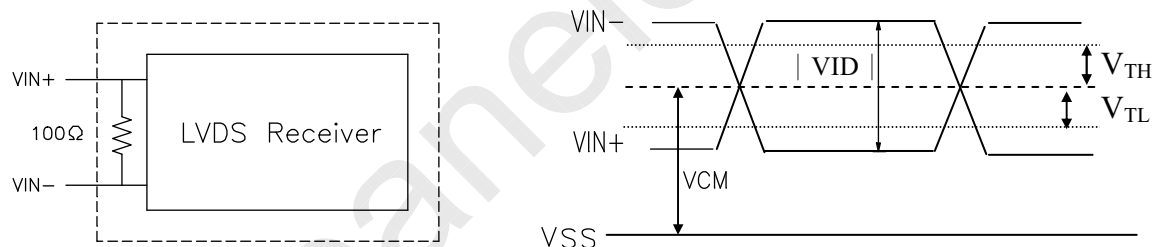

VIN+ : Positive differential DATA & CLK Input

VIN- : Negative differential DATA & CLK Input

\*4).Irush Measurement Condition

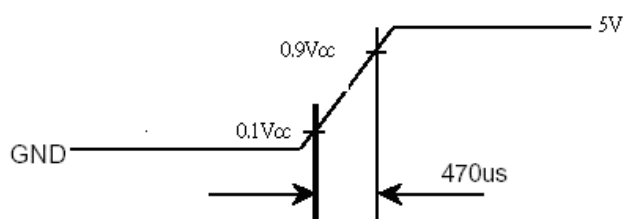
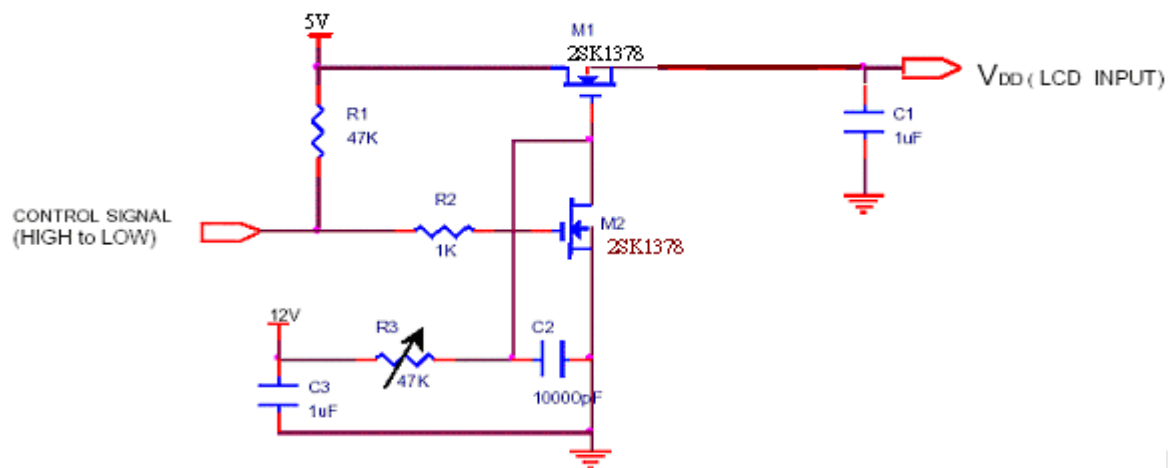

## (2).Backlight

## 1. Electrical specification

Ta=25°C (Ta: ambient temperature)

Symbol	Parameter	Min	TYP	MAX	UNIT	REMARK
$V_F$	LED Operation Voltage (for reference)	47.2	52	57.6	V	
$I_F$	LED Operation Current	57	60	63	mA	1)
$P_{out}$	BLU Power	10.76	12.48	14.52	W	

## 2. CN2

Type Part Number	CI1406M1HRE-NH(CviLux) / 116B06-100000-M1-R(Starconn) or compatible
Mating Housing Part Number	CI1406SL000-NH(CviLux) / H11620-1006-1R(Starconn)

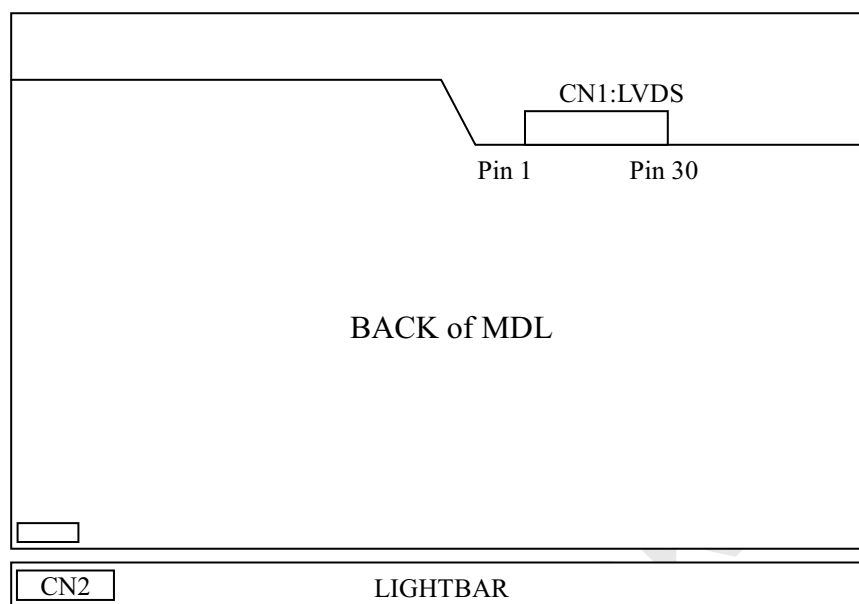

Pin 1 Pin 6

Pin	Name	Description
1	LED_04	String 16PcsLED , feedback 60mA
2	LED_03	String 16PcsLED , feedback 60mA
3	VLED+	VLED+ , 4Parallel 16String ; 64Pcs LED
4	VLED+	VLED+ , 4Parallel 16String ; 64Pcs LED
5	LED_02	String 16PcsLED , feedback 60mA
6	LED_01	String 16PcsLED , feedback 60mA

## 3. life time

ITEM	min	typ	max	UNIT	REMARK
LIFE TIME	30000	--	--	hrs	2) , 3) , 4) , 5)

[Note]

- 1).If dimming function is required, it is strongly recommended to adopt pulse width modulation (PWM).If not, linear decrease of the driving current will affect the optical characteristics
- 2).Parameter guideline for LED driving is under stable conditions at 25°C (Room Temperature) and  $I_F=60mA$
- 3). Definition of the lamp life time: Luminance (L) under 50% of specification.
- 4). When the ambient temperature  $T_a$  overstep 25°C, it will serious damage life time.
- 5). When the LED operation current  $I_F$  overstep 60mA, it will serious damage life time.

## 4. INTERFACE PIN CONNECTION

## (1) CNI

Type Part Number	093F30-0PT01A-M4(STARCONN) / MSCK2407P30H (STM) or compatible
Mating Housing Part Number	FI-X30HL(JAE) FI-X30H(JAE)

PIN NO.	REMARK	FUNCTION
1	RXO0-	minus signal of odd channel 0(LVDS)
2	RXO0+	plus signal of odd channel 0(LVDS)
3	RXO1-	minus signal of odd channel 1(LVDS)
4	RXO1+	plus signal of odd channel 1(LVDS)
5	RXO2-	minus signal of odd channel 2(LVDS)
6	RXO2+	plus signal of odd channel 2(LVDS)
7	GND	GND
8	RXOC-	minus signal of odd clock channel (LVDS)
9	RXOC+	plus signal of odd clock channel (LVDS)
10	RXO3-	minus signal of odd channel 3(LVDS)
11	RXO3+	plus signal of odd channel 3(LVDS)
12	RXE0-	minus signal of even channel 0(LVDS)
13	RXE0+	plus signal of even channel 0(LVDS)
14	GND	GND
15	RXE1-	minus signal of even channel 1(LVDS)
16	RXE1+	plus signal of even channel 1(LVDS)
17	GND	GND
18	RXE2-	minus signal of even channel 2(LVDS)
19	RXE2+	plus signal of even channel 2(LVDS)
20	RXEC-	minus signal of even clock channel (LVDS)
21	RXEC+	plus signal of even clock channel (LVDS)
22	RXE3-	minus signal of even channel 3(LVDS)
23	RXE3+	plus signal of even channel 3(LVDS)
24	GND	GND
25	NC	NC
26	NC	Test pin (Can't connect to GND)
27	NC	NC
28	VCC	Power supply input voltage(5.0 V)
29	VCC	Power supply input voltage(5.0 V)
30	VCC	Power supply input voltage(5.0 V)

1) Keep the NC Pin and don't connect it to GND or other signals.

2) GND Pin must connect to the ground, don't let it be a vacant pin.



## 5. INTERFACE TIMING

## (1) Timing Characteristic

ITEM		SYMBOL	MIN.	TYP.	MAX.	UNIT	
LCD Timing	DCLK	Freq.	$f_{CLK}$	55	72	90	MHz
		Cycle	$t_{CLK}$	18.18	13.89	11.11	ns
	Horizontal	Horizontal effective time	$t_{HA}$	960	960	960	$t_{CLK}$
		Horizontal blank time	$t_{HB}$	40	100	160	$t_{CLK}$
		Horizontal total time	$t_H$	1000	1060	1120	$t_{CLK}$
	Vertical	Vertical frame Rate	Fr	50	60	75	Hz
		Vertical total time	$t_V$	1090	1130	1230	$t_H$
		Vertical effective time	$t_{VA}$	1080	1080	1080	$t_H$
		Vertical blank time	$t_{VB}$	10	50	150	$t_H$

[Note]

- \*1) DENA (data enable) usually is positive
- \*2) DCLK still inputs during blanking
- \*3) DE mode only
- \*4) It maybe cause flicker at 50Hz.

## (2).Timing Chart

## a. Horizontal Signal

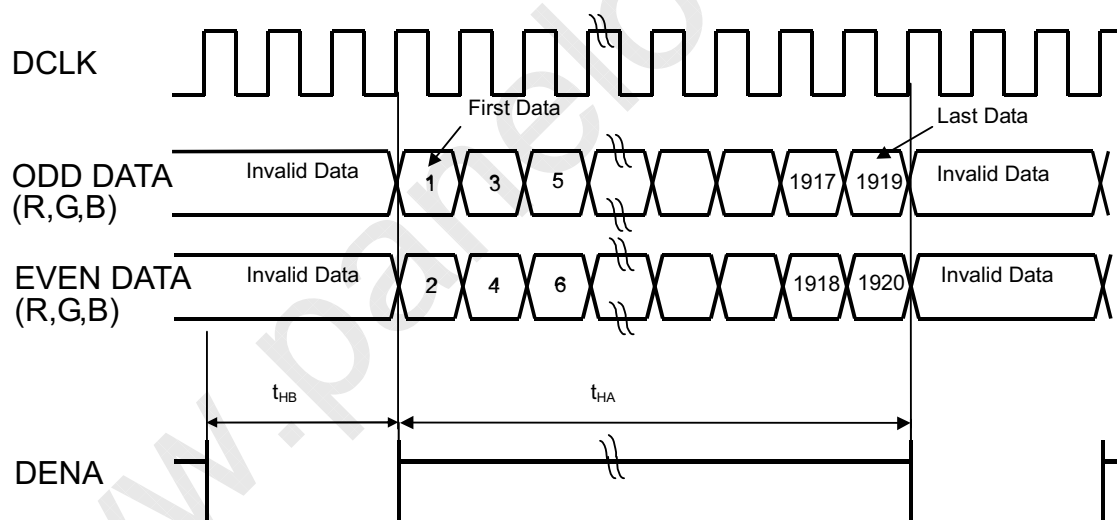

b. Vertical Signal

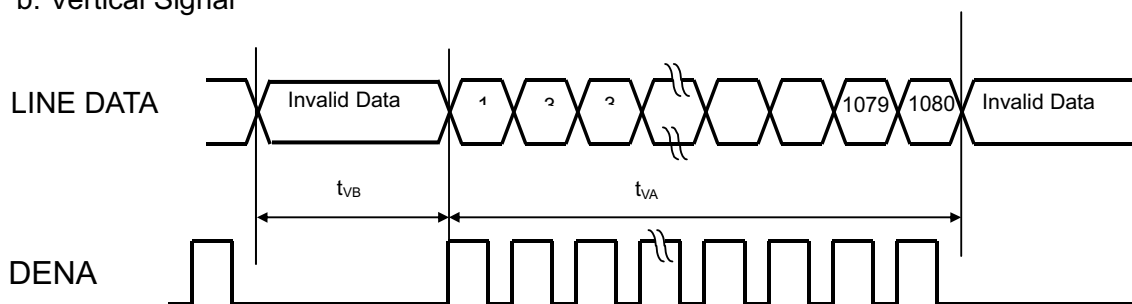

(3).LVDS Data

For 6Bit+Hi-FRC

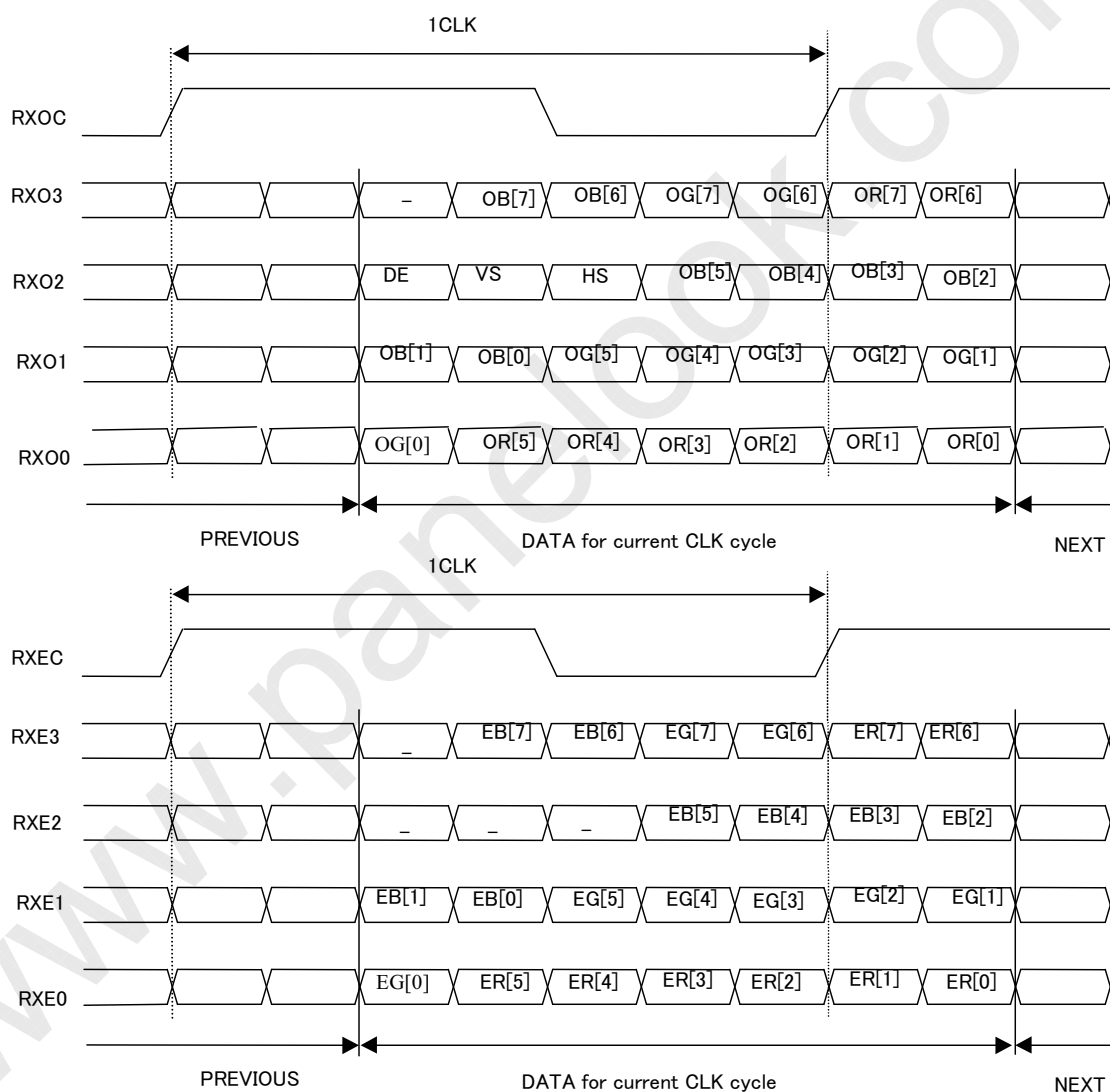

Color Data Assignment

COLOR	INPUT DATA	R DATA								G DATA								B DATA							
		R7	R6	R5	R4	R3	R2	R1	R0	G7	G6	G5	G4	G3	G2	G1	G0	B7	B6	B5	B4	B3	B2	B1	B0
		MSB							LSB	MSB							LSB	MSB							LSB
BASIC COLOR	BLACK	0	0	0	0	0	0	0	0	0	0	0	0	0	0	0	0	0	0	0	0	0	0	0	0
	RED(255)	1	1	1	1	1	1	1	1	0	0	0	0	0	0	0	0	0	0	0	0	0	0	0	0
	GREEN(255)	0	0	0	0	0	0	0	0	1	1	1	1	1	1	1	1	0	0	0	0	0	0	0	0
	BLUE(255)	0	0	0	0	0	0	0	0	0	0	0	0	0	0	0	0	1	1	1	1	1	1	1	1
	CYAN	0	0	0	0	0	0	0	0	1	1	1	1	1	1	1	1	1	1	1	1	1	1	1	1
	MAGENTA	1	1	1	1	1	1	1	1	0	0	0	0	0	0	0	0	1	1	1	1	1	1	1	1
	YELLOW	1	1	1	1	1	1	1	1	1	1	1	1	1	1	1	1	0	0	0	0	0	0	0	0
	WHITE	1	1	1	1	1	1	1	1	1	1	1	1	1	1	1	1	1	1	1	1	1	1	1	1
RED	RED(0)	0	0	0	0	0	0	0	0	0	0	0	0	0	0	0	0	0	0	0	0	0	0	0	0
	RED(1)	0	0	0	0	0	0	0	1	0	0	0	0	0	0	0	0	0	0	0	0	0	0	0	0
	RED(2)	0	0	0	0	0	0	1	0	0	0	0	0	0	0	0	0	0	0	0	0	0	0	0	0
	RED(254)	1	1	1	1	1	1	1	0	0	0	0	0	0	0	0	0	0	0	0	0	0	0	0	0
	RED(255)	1	1	1	1	1	1	1	1	0	0	0	0	0	0	0	0	0	0	0	0	0	0	0	0
GREEN	GREEN(0)	0	0	0	0	0	0	0	0	0	0	0	0	0	0	0	0	0	0	0	0	0	0	0	0
	GREEN(1)	0	0	0	0	0	0	0	0	0	0	0	0	0	0	1	0	0	0	0	0	0	0	0	0
	GREEN(2)	0	0	0	0	0	0	0	0	0	0	0	0	0	0	1	0	0	0	0	0	0	0	0	0
	GREEN(254)	0	0	0	0	0	0	0	0	1	1	1	1	1	1	1	0	0	0	0	0	0	0	0	0
	GREEN(255)	0	0	0	0	0	0	0	0	1	1	1	1	1	1	1	1	0	0	0	0	0	0	0	0
BLUE	BLUE(0)	0	0	0	0	0	0	0	0	0	0	0	0	0	0	0	0	0	0	0	0	0	0	0	0
	BLUE(1)	0	0	0	0	0	0	0	0	0	0	0	0	0	0	0	0	0	0	0	0	0	0	0	1
	BLUE(2)	0	0	0	0	0	0	0	0	0	0	0	0	0	0	0	0	0	0	0	0	0	0	1	0
	BLUE(254)	0	0	0	0	0	0	0	0	0	0	0	0	0	0	0	0	1	1	1	1	1	1	1	0
	BLUE(255)	0	0	0	0	0	0	0	0	0	0	0	0	0	0	0	0	1	1	1	1	1	1	1	1

- [Note] 1) Definition of gray scale: Color (n): n indicates gray scale level; higher n means brighter level.  
 2) Data: 1-High, 0-Low.  
 3)For odd & even data also.

(4).Color Data Distribution

D(1,1)	D(2,1)	..	D(X,1)	..	D(1919,1)	D(1920,1)
D(1,2)	D(2,2)	..	D(X,2)	..	D(1919,2)	D(1920,2)
..	..	+	..	+	..	..
D(1,Y)	D(2,Y)	..	D(X,Y)	..	D(1919,Y)	D(1920,Y)
..	..	+	..	+	..	..
D(1,1079)	D(2, 1079)	..	D(X, 1079)	..	D(1919, 1079)	D(1920, 1079)
D(1, 1080)	D(2, 1080)	..	D(X, 1080)	..	D(1919, 1080)	D(1920,1080)

6. BLOCK DIAGRAM

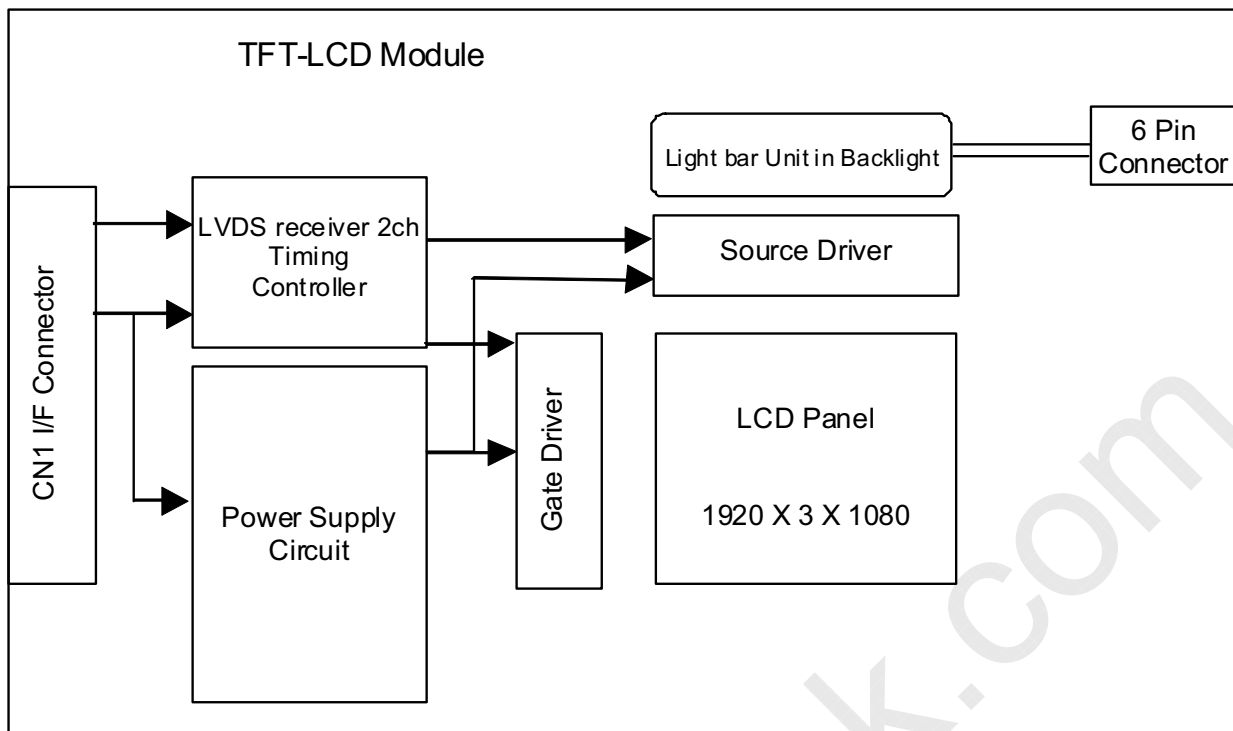

CPT

CHUNGHWA PICTURES TUBES, LTD.,

## 7. MECHANICAL SPECIFICATION

(1) Front side (Tolerance is  $\pm 0.5\text{mm}$  unless noted)

[Unit: mm]

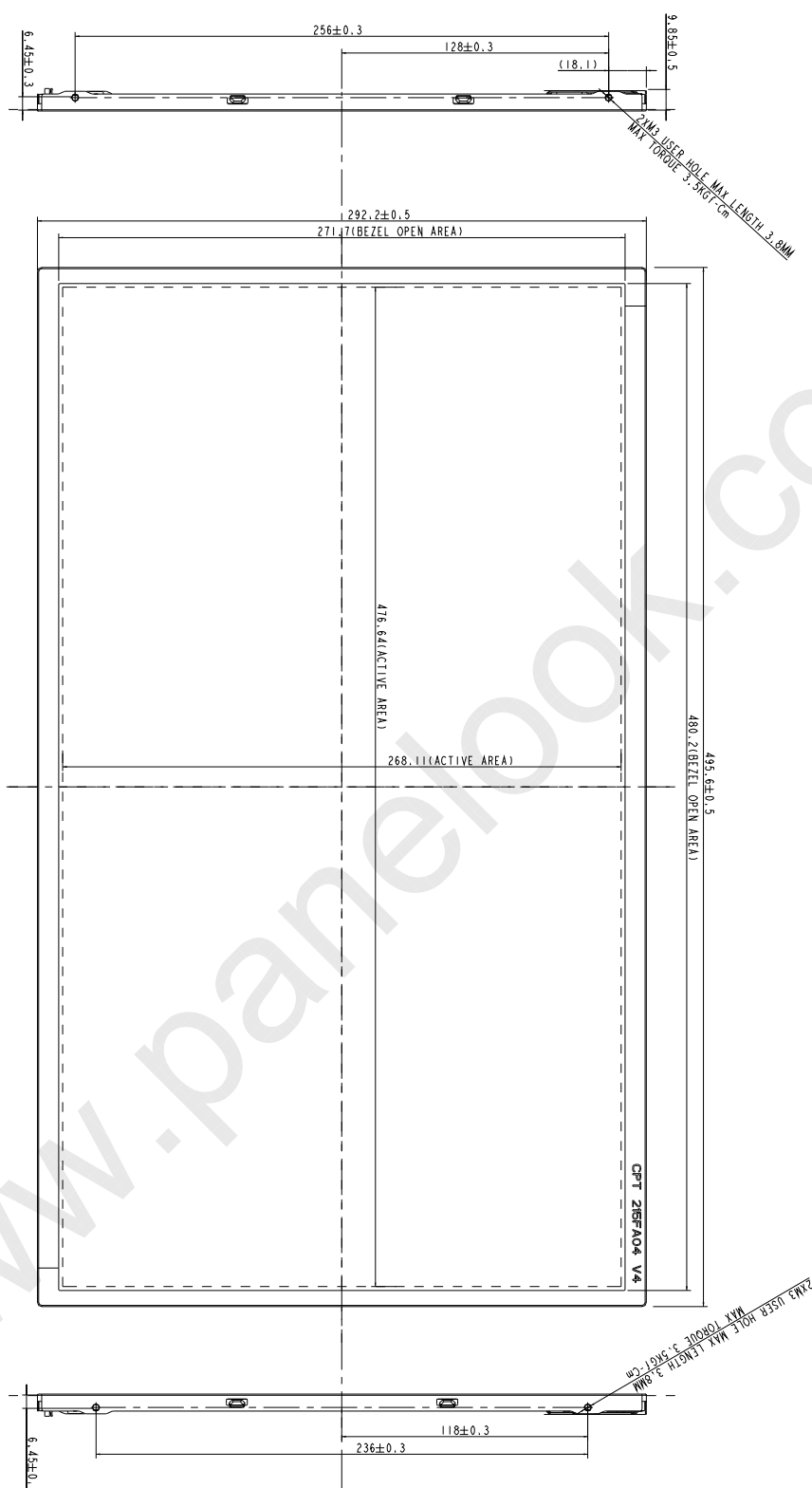
(2) Rear side (Tolerance is  $\pm 0.5\text{mm}$  unless noted)

[Unit: mm]

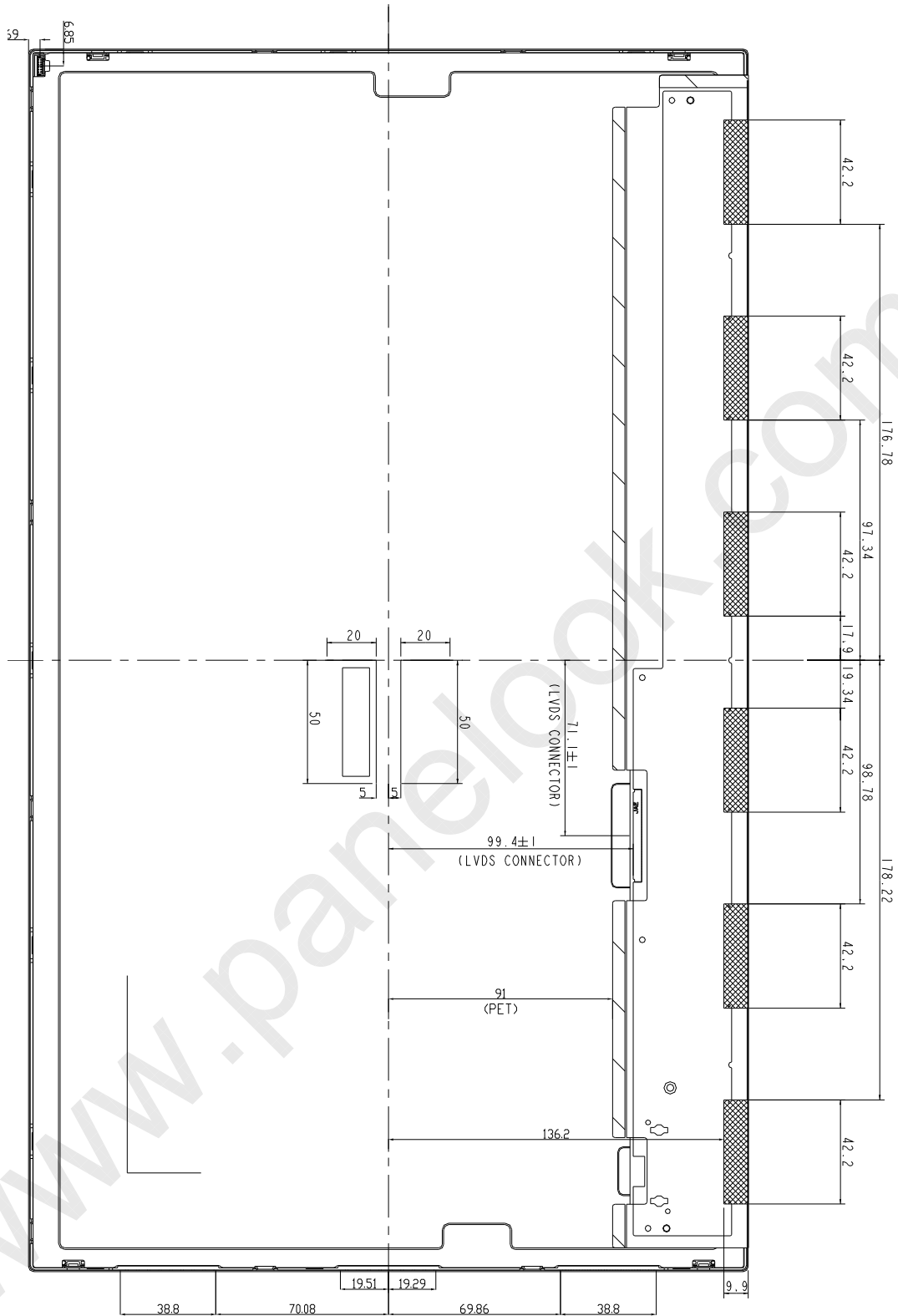

## 8. OPTICAL CHARACTERISTICS

Ta=25°C , VCC=5.0V

ITEM	SYMBOL	CONDITION	MIN.	TYP.	MAX.	UNIT	REMARK	
Contrast (CEN)	CR	$\theta=\psi= 0^\circ$	650	1000	--	--	*1) 2)	
Luminance (CEN)	L	$\theta=\psi= 0^\circ$	180	250	--	cd/m2	*1) 3)	
9P Uniformity	$\Delta L$	$\theta=\psi= 0^\circ$	70	--	--	%	*1) 3)	
Response Time	Tr+Tf	$\theta=\psi= 0^\circ$	--	5	10	ms	*5)	
Cross talk	CT	$\theta=\psi= 0^\circ$	--	--	1.5	%	*6)	
View angle	Horizontal	$\psi$	$CR \geq 10$	150	160	--	Deg.	*4)
	Vertical	$\theta$		140	160	--	Deg.	
	Horizontal	$\psi$	$CR \geq 5$	150	170	--	Deg.	
	Vertical	$\theta$		150	170	--	Deg.	
Color Coordinates	White	x	$\theta=\psi= 0^\circ$	0.283	0.313	0.343	Color Coordinates	*3)
		y		0.299	0.329	0.359		
	Red	x		0.613	0.643	0.673		
		y		0.323	0.353	0.383		
	Green	x		0.299	0.329	0.359		
		y		0.599	0.629	0.659		
	Blue	x		0.124	0.154	0.184		
		y		0.027	0.057	0.087		
Gamma	$\gamma$	VESA	2.0	2.2	2.4	--	*7)	

[Note]

Definition of these measurement items is as follows:

## 1) Setup of Measurement Equipment

The LCD module should be turn-on to a stable luminance level to be reached. The measurement should be executed after lighting Backlight for 20 minutes and in a dark room.

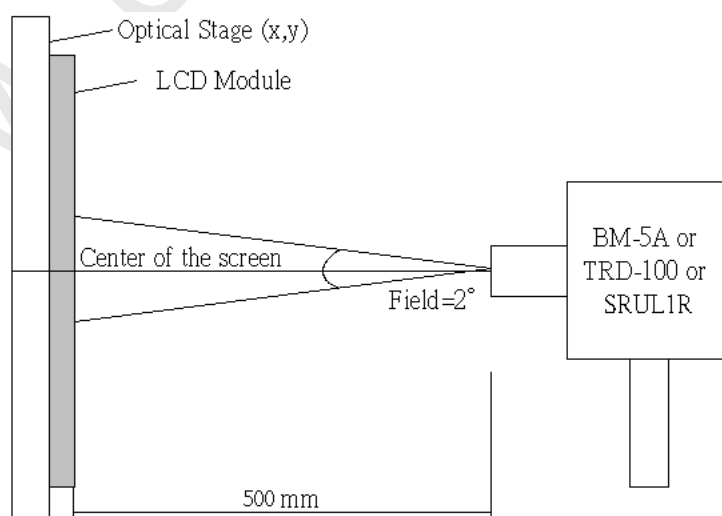

## 2) Definition of Contrast Ratio

CR=ON (White) Luminance/OFF (Black) Luminance

### 3) Definition of Luminance and Luminance uniformity

Central luminance: The white luminance is measured at the center position "5" on the screen, see Fig.1 below. And the measure time is 30 min after discharged.

9P Luminance (AVG): The white luminance is measured at measuring points 1 to 9, see Fig.1 below.

9P Uniformity:  $\Delta L = (L_{MIN} / L_{MAX}) \times 100\%$

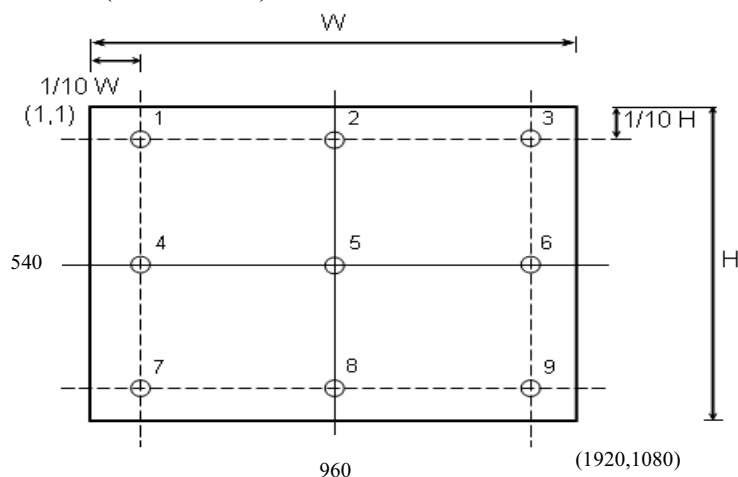

### 4).Definition of Viewing Angle ( $\theta, \psi$ ):

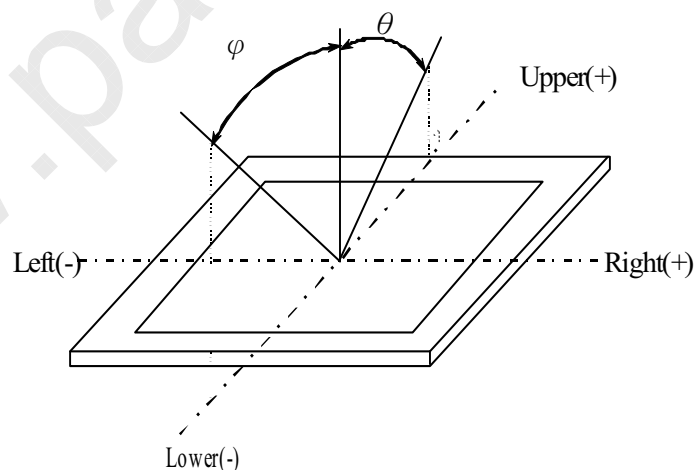

### 5) Definition of Response Time:



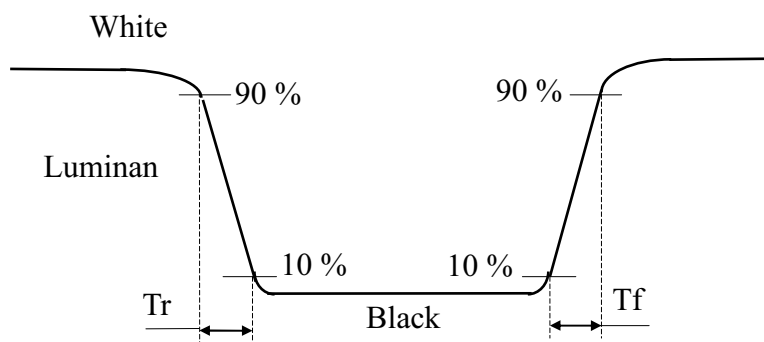

6) Definition of crosstalk:

$$CT = |Y_B - Y_A| / Y_A \times 100 (\%)$$

$Y_A$ : The luminance of measured position at pattern A

$Y_B$ : The luminance of measured position at pattern B with Gray level 0

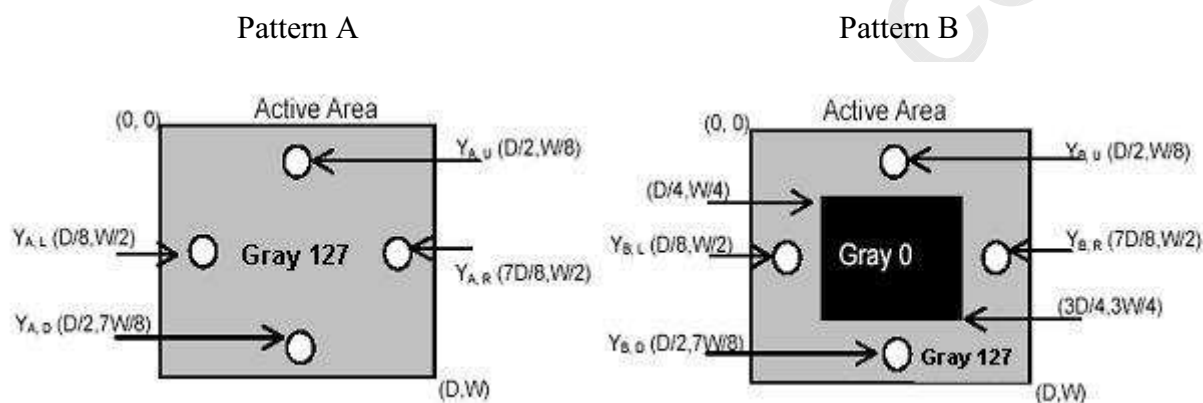

7) Definition of Gamma ( $\gamma$ ), follow VESA standard sampling every 16 gray level (0,16,32,.....224,240,255)

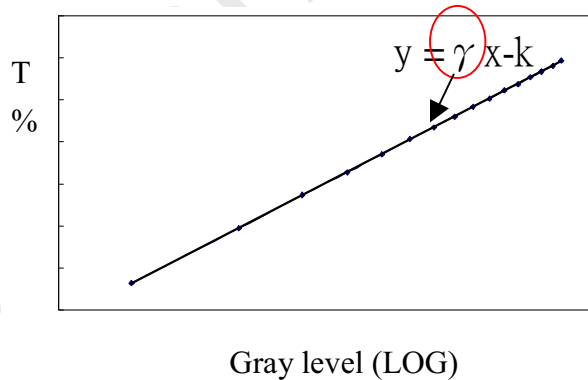

## 9. RELIABILITY TEST CONDITIONS

## (1) Temperature and Humidity

TEST ITEMS	CONDITIONS
HIGH TEMPERATURE HIGH HUMIDITY OPERATION	50°C ; 90%RH; 240h (No condensation)
HIGH TEMPERATURE HIGH HUMIDITY STORAGE	60°C ; 90%RH; 48h (No condensation)
HIGH TEMPERATURE OPERATION	50°C ; 240h
HIGH TEMPERATURE STORAGE	60°C ; 240h
LOW TEMPERATURE OPERATION	0°C ; 240h
LOW TEMPERATURE STORAGE	-20°C ; 240h
THERMAL SHOCK	BETWEEN -20°C (1hr) AND 60°C (1hr); 100 CYCLES

## (2) Shock &amp; Vibration

ITEMS	CONDITIONS
SHOCK (NON-OPERATION)	Shock level: 980m/s <sup>2</sup> (150G) Waveform: half sinusoidal wave, 2ms Number of shocks: one shock input in each direction of three mutually perpendicular axes for a total of six shock inputs
VIBRATION (NON-OPERATION)	Vibration level: 9.8m/s <sup>2</sup> (1.0G) zero to peak Waveform: sinusoidal Frequency range: 5 to 500 Hz Frequency sweep rate: 0.5 octave/min Duration: one sweep from 5 to 500Hz in each of three mutually perpendicular axis (each x,y,z axis: 1 hour, total 3 hours)

## (3) ESD

POSITION	CONDITION (MDL turn off)
Connector	1. 200 pF , 0 Ω , ±250 V 2. contact mode for each pin
Module	1. 150 pF , 330 Ω , ±15K V 2. Air mode, test 25 times for each test point 3. Contact mode, 25 times for each test point

## (4) Low Pressure test

TEST ITEM	CONDITION
Low Pressure test (storage)	260HPa (30000 ft.) ; 24 Hr

## (5) Judgment standard

The judgment of the above test should be made as follow:

Pass: Normal display image with no obvious non-uniformity and no line defect. Partial transformation of the module parts should be ignored.

Fail: No display image, obvious non-uniformity, or line defects.

## 10. HANDLING PRECAUTIONS FOR TFT-LCD MODULE

Please pay attention to the followings in handling- TFT-LCD products;

### 1. ASSEMBLY PRECAUTION

- (1) Please use the mounting hole on the module side in installing and do not beading or wrenching LCD in assembling. And please do not drop, bend or twist LCD module in handling.
- (2) Please design display housing in accordance with the following guide lines.
  - (2.1) Housing case must be destined carefully so as not to put stresses on LCD all sides and not to wrench module. The stresses may cause non-uniformity even if there is no non-uniformity statically.
  - (2.2) Keep sufficient clearance between LCD module back surface and housing when the LCD module is mounted. Approximately 1.0 mm of the clearance in the design is recommended taking into account the tolerance of LCD module thickness and mounting structure height on the housing.
  - (2.3) When some parts, such as, FPC cable and ferrite plate, are installed underneath the LCD module, still sufficient clearance is required, such as 0.5mm. This clearance is, especially, to be reconsidered when the additional parts are implemented for EMI countermeasure.
  - (2.4) Design the inverter location and connector position carefully so as not to give stress to lamp cable, or not to interface the LCD module by the lamp cable.
  - (2.5) Keep sufficient clearance between LCD module and the others parts, such as inverter and speaker so as not to interface the LCD module. Approximately 1.0mm of the clearance in the design is recommended.
- (3) Please do not push or scratch LCD panel surface with any-thing hard. And do not soil LCD panel surface by touching with bare hands. (Polarizer film, surface of LCD panel is easy to be flawed.)
- (4) Please do not press any parts on the rear side such as source TCP, gate TCP, control circuit board and FPCs during handling LCD module. If pressing rear part is unavoidable, handle the LCD module with care not to damage them.
- (5) Please wipe out LCD panel surface with absorbent cotton or soft cloth in case of it being soiled.
- (6) Please wipe out drops of adhesives like saliva and water on LCD panel surface immediately. They might damage to cause panel surface variation and color change.
- (7) Please do not take a LCD module to pieces and reconstruct it. Resolving and reconstructing modules may cause them not to work well.
- (8) Please do not touch metal frames with bare hands and soiled gloves. A color change of the metal frames can happen during a long preservation of soiled LCD modules.
- (9) Please pay attention to handling lead wire of backlight so that it is not tugged in connecting with inverter.

### 2. OPERATING PRECAUTIONS

- (1) Please be sure to turn off the power supply before connecting and disconnecting signal input

cable.

- (2) Please do not change variable resistance settings in LCD module. They are adjusted to the most suitable value. If they are changed, it might happen LCD does not satisfy the characteristics specification.
- (3) Please consider that LCD backlight takes longer time to become stable of radiation characteristics in low temperature than in room temperature.
- (4) A condensation might happen on the surface and inside of LCD module in case of sudden change of ambient temperature.
- (5) Please pay attention to displaying the same pattern for very long time. Image might stick on LCD. If then, time going on can make LCD work well.
- (6) Please obey the same caution descriptions as ones that need to pay attention to ordinary electronic parts.

### 3. PRECAUTIONS WITH ELECTROSTATICS

- (1) This LCD module use CMOS-IC on circuit board and TFT-LCD panel, and so it is easy to be affected by electrostatics. Please be careful with electrostatics by the way of your body connecting to the ground and so on.
- (2) Please remove protection film very slowly on the surface of LCD module to prevent from electrostatics occurrence.

### 4. STORAGE PRECAUTIONS

- (1) When you store LCDs for a long time, it is recommended to keep the temperature between 0°C ~40°C without the exposure of sunlight and to keep the humidity less than 90%RH.
- (2) Please do not leave the LCDs in the environment of high humidity and high temperature such as 60°C 90%RH.
- (3) Please do not leave the LCDs in the environment of low temperature; below -20°C.

### 5. SAFETY PRECAUTIONS

- (1) When you waste LCDs, it is recommended to crush damaged or unnecessary LCDs into pieces and wash them off with solvents such as acetone and ethanol, which should later be burned.
- (2) If any liquid leaks out of a damaged-glass cell and comes in contact with the hands, wash off thoroughly with soap and water.

### 6. OTHERS

- (1) A strong incident light into LCD panel might cause display characteristics' changing inferior because of polarizer film, color filter, and other materials becoming inferior. Please do not expose LCD module direct sunlight and strong UV rays.
- (2) Please pay attention to a panel side of LCD module not to contact with other materials in preserving it alone.
- (3) For the packaging box, please pay attention to the followings:

- (3.1) Packaging box and inner case for LCD are designed to protect the LCDs from the damage or scratching during transportation. Please do not open except picking LCDs up from the box.
- (3.2) Please do not pile them up more than 5 boxes. (They are not designed so.) And please do not turn over.
- (3.3) Please handle packaging box with care not to give them sudden shock and vibrations. And also please do not throw them up.
- (3.4) Packing box and inner case for LCDs are made of cardboard. So please pay attention not to get them wet. (Such like keeping them in high humidity or wet place can occur getting them wet.)