



Chunghwa Picture Tubes, Ltd.

Technical Specification

CPT TFT-LCD
CLAA 220UA01A

APPROVED BY	CHECKED BY	PREPARED BY

Prepared by: Design General Division

CHUNGHWA PICTUER TUBES, LTD.

No. 1, Huaying Rd., Sanho Tsun, Lungtan Shiang, Taoyuan, Taiwan, 325, R.O.C.
TEL: +886-3-4805678 FAX: +886-3-4800589

Doc. No:	CLAA220UA01A	Issue Date:	2008/07/15
----------	---------------------	-------------	------------



CHUNGHWA PICTUER TUBES, LTD.

TECHNICAL SPECIFICATION

Doc. No : _____
Version : A
Issue Date : 2008/07/15

Title : CLAA220UA01A Technical Specification

Modification Record List

NO.	Issue Date	Modification Index
A	2008/07/15	Tentative version for the customer

CHUNGHWA PICTUER TUBES, LTD.

TECHNICAL SPECIFICATION

Doc. No : _____

Version : AIssue Date : 2008/07/15**Title : CLAA220UA01A Technical Specification****Table Of Content**

NO	Table of Content	Note
1	OVERVIEW	P.4
2	ABSOLUTE MAXIMUM RATINGS	P.5
3	ELECTRICAL CHARACTERISTICS	P.6
4	INTERFACE PIN CONNECTION	P.10
5	INTERFACE TIMING	P.12
6	BLOCK DIAGRAM	P.15
7	MECHANICAL SPECIFICATION	P.16
8	OPTICAL CHARACTERISTICS	P.18
9	RELIABILITY TEST CONDITIONS	P.22
10	DESIGNATION OF LOT MARK	P.23
11	PACKING SPECIFICATION	P.25
12	HANDLING PRECAUTIONS FOR TFT-LCD MODULE	P.27

CHUNGHWA PICTUER TUBES, LTD.

TECHNICAL SPECIFICATION

Doc. No : _____

Version : AIssue Date : 2008/07/15**Title : CLAA220UA01A Technical Specification****1. OVERVIEW**

CLAA220UA01A is 21.6" color TFT-LCD (Thin Film Transistor Liquid Crystal Display) module composed of LCD panel, driver ICs, control circuit and backlight. By applying 6 bit digital data, 1680×1050, 16.7M-color images are displayed on the 21.6" diagonal screen. Input power voltage is 5.0V for LCD driving. General specification is summarized in the following table:

ITEM	SPECIFICATION
Display Area(mm)	464.94 (H) × 290.5875 (V) (22.0-inch diagonal)
Number of Pixels	1680 (H) × 1050(V)
Pixel Pitch(mm)	0.27675(H) × 0.27675(V)
Color Pixel Arrangement	RGB vertical stripe
Display Mode	Normally white, TN
Number of Colors	16.7M(6bits+Hi-FRC)
Brightness(cd/m ²)	280cd/m ² (Typ.)(center, 20mA)
Viewing Angle(H/V)	170/160 (Typ.)
Surface Treatment	glare, 3H
Power consumption(W)	23.4(Typ.) (w/o Inverter)
Module Size(mm)	493.7 (W) × 320.1(H) × 13.5(D) (Typ.)
Module Weight(g)	1850(Typ.)
Backlight Unit	LED, 228pcs white-LED

CHUNGHWA PICTUER TUBES, LTD.

TECHNICAL SPECIFICATION

Doc. No : _____

Version : AIssue Date : 2008/07/15**Title : CLAA220UA01A Technical Specification****2. ABSOLUTE MAXIMUM RATINGS**

ITEM	SYMBOL	MIN.	MAX.	UNIT	REMARK
Power Supply Voltage for LCD	VCC	0	6	V	
LED Forward voltage	AOT	3.0	3.5	V	1). 2).
	EL	2.9	3.6		
LED Forward current	AOT	--	30	mA	
	EL	--	30		
Operation Temperature	Top	(0)	(50)	°C	3). 4). 5). 6)
Storage Temperature	Tstg	(-20)	(60)	°C	3). 4). 5). 6)

[Note]

- Product life-time relate to LED, please operate production follow statement at page 9 "(b)back light" .
- When LED current over the definition of operating current (at 20mA), product life-time will decay rapidly or operate unusual.
- The relative temperature and humidity range are as below sketch, 90%RHMax. ($T_a \leq 40^\circ\text{C}$).
- The maximum wet bulb temperature $\leq 39^\circ\text{C}$ ($T_a > 40^\circ\text{C}$) and without dewing.
- If you use the product in an environment which over the definition of temperature and humidity too long to effect the result of eye-etching.
- If you operate the product in normal temperature range, the center surface of panel should be under 60°C .

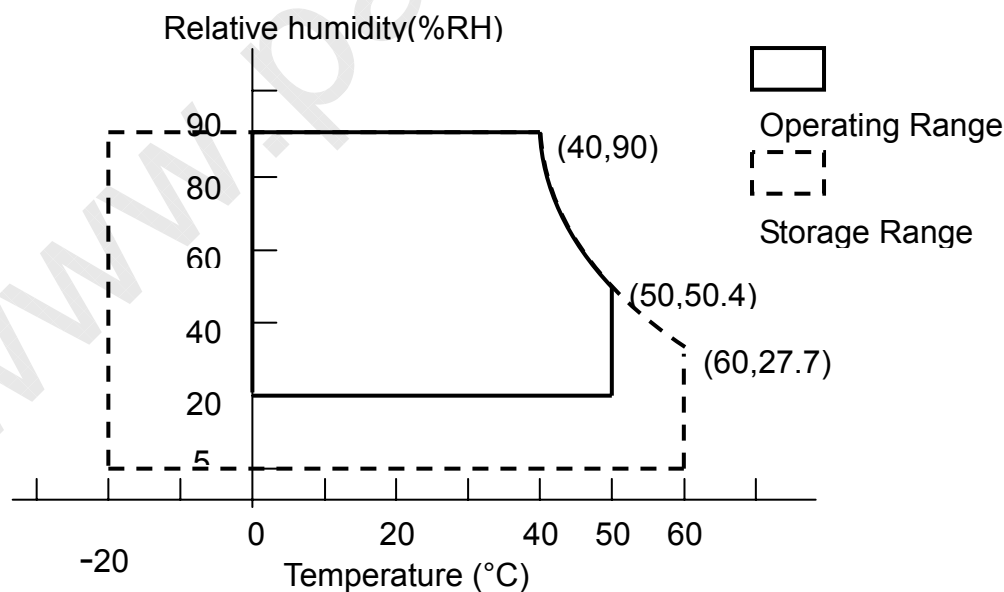

CHUNGHWA PICTUER TUBES, LTD.

TECHNICAL SPECIFICATION

Doc. No : _____

Version : AIssue Date : 2008/07/15**Title : CLAA220UA01A Technical Specification****3. ELECTRICAL CHARACTERISTICS****(1).TFT-LCD**

Ta=25°C

ITEM		SYMBOL	MIN	TYP	MAX	UNIT	REMARK
Power Supply Voltage for LCD		VCC	4.5	5.0	5.5	V	1).
Power Supply Current for LCD		ICC	--	900	1500	mA	2).
Permissible Ripple Voltage for Logic		VRP	--	--	100	mVp-p	VCC=5.0V
Differential Resistance		Zm	90	100	110	Ω	
LVDS: IN+ , IN-	The same motion input Voltage	VCM	1.125	1.25	1.375	V	3).
	Differential input Voltage	VID	250	350	450	mV	
	High electric potential threshold voltage	VTH	-	-	100	mV	
	Low electric potential threshold voltage	VTL	-100	-	-	mV	
LCD Irush Current		Irush	-	-	3	A	4).
Power consumption		P	-	4.5	7.5	W	2).

[Note]

1).Power 、 data sequence

$0.5\text{ms} < t1 < 10\text{ms}$

$0 < t2 < 50\text{ms}$

$t3 > 250\text{ms}$

$t4 > 200\text{ms}$

$0 < t5 < 50\text{ms}$

$0.01\text{ms} < t6 < 10\text{ms}$

$t7 > 1\text{sec}$

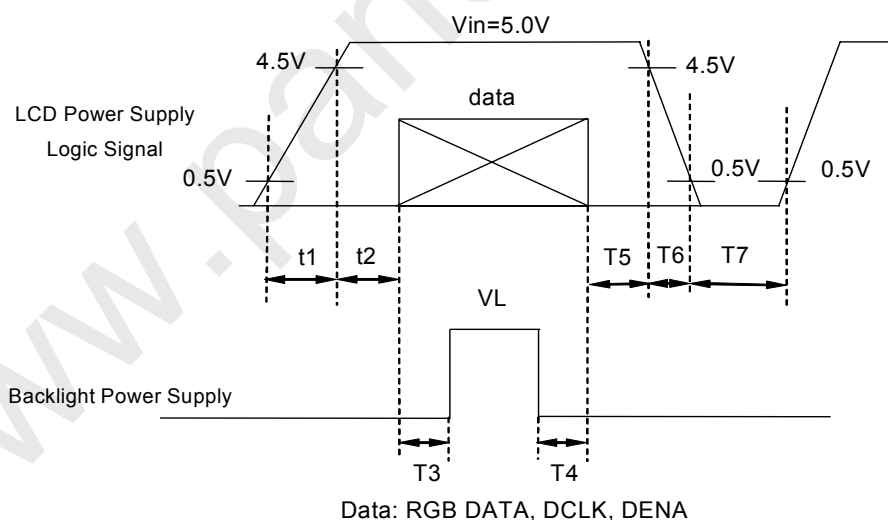

VCC-dip conditions:

(1) When $3.6\text{V} \leq V_{cc}(\text{min}) < 4.5\text{V}$: $t_d \leq 10\text{ms}$ (2) When $V_{cc} < 3.6\text{V}$, VCC-dip conditions should also follow the VCC-turn-on conditions.

CHUNGHWA PICTUER TUBES, LTD.

TECHNICAL SPECIFICATION

Doc. No : _____

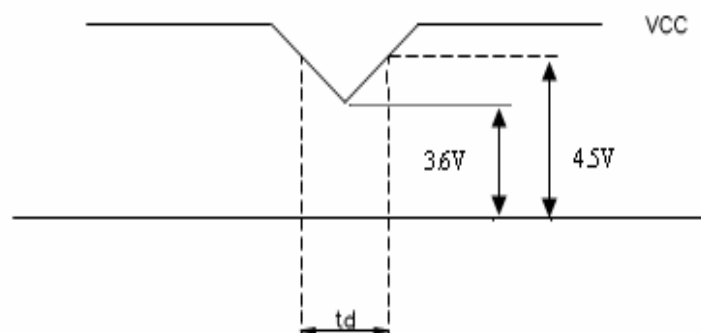
Version : AIssue Date : 2008/07/15**Title : CLAA220UA01A Technical Specification**

2). Typical value is measured when displaying horizontal gray scale line pattern:

64 gray level, 1680 line mode

$V_{CC}=5.0\text{ V}$, $f_H=65\text{ kHz}$, $f_V=60\text{ Hz}$, $f_{CLK}=73.5\text{ MHz}$

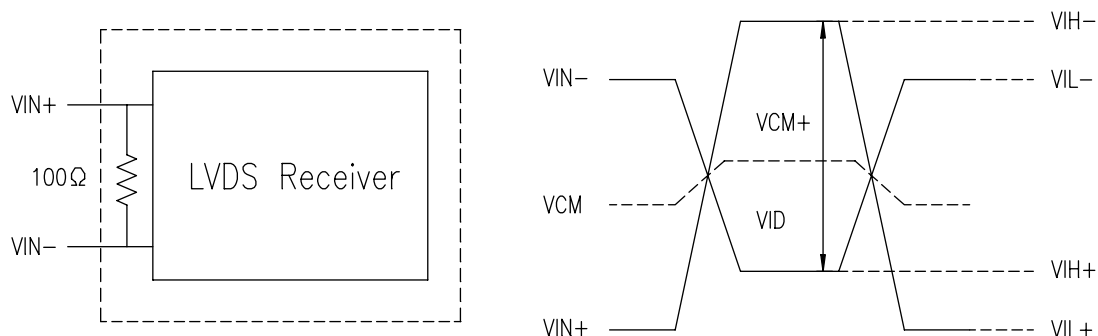

3).LVDS Signal definition:

VIN+ : Positive differential DATA & CLK Input

VIN- : Negative differential DATA & CLK Input

4).Irush Measurement Condition

CHUNGHWA PICTUER TUBES, LTD.

TECHNICAL SPECIFICATION

Doc. No : _____

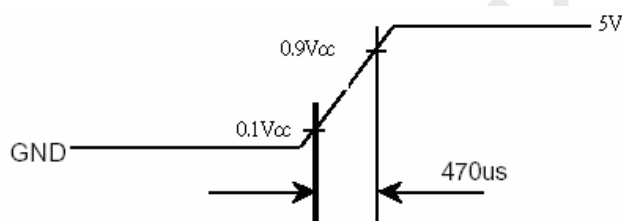
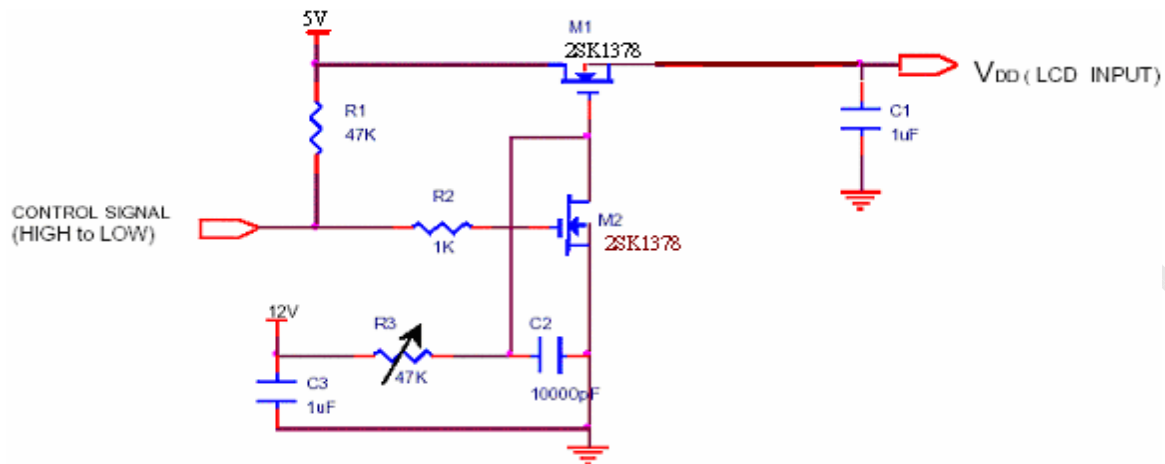
Version : A Issue Date : 2008/07/15 **Title : CLAA220UA01A Technical Specification****(2).Backlight**

1. Electrical specification

1) single LED

Ta=25°C (Ta: ambient temperature)

ITEM	SYMBOL	MIN	TYP	MAX	UNIT	REMARK	
Forward Voltage	V _F	AOT	3.0	3.3	3.5	V	I _F =20mA
		EL	2.9	3.3	3.6		
Forward Current	I _F	AOT	(18.98)	20	(21.4)	mA	1).
		EL	(18.98)	20	(21.4)		
Power consumption	W	AOT	(60)	(66)	(72)	mW	I _F =20mA
		EL	(58)	(66)	(70)		

CHUNGHWA PICTUER TUBES, LTD.

TECHNICAL SPECIFICATION

Doc. No : _____

Version : AIssue Date : 2008/07/15**Title : CLAA220UA01A Technical Specification**

2) Converter

LED AND DRIVER ELECTRICAL CHARACTERISTICS

ITEM	SYMBOL	MIN	TYP	MAX	UNIT	REMARK
Input Voltage of Inverter	VIN	10.8	12	13.2	V	
Input Current of Inverter	IIN	(1.38)	1.57	(1.71)	A	
PWM Dimming Control Voltage	HIGH	VPWMIN	3.0	--	5.0	V
	LOW		0	--	0.8	V
PWM Dimming Control Frequency	FPWMIN	--	16K	--	Hz	
Backlight on /off Control Voltage	ON	EN	3.0	--	5.0	V
	OFF		0	--	0.8	
Power Consumption (Backlight)	BLW	(16.6)	18.9	(20.52)	W	Vin=12V 4).

2. life-time

ITEM	Condition	MIN	TYP	MAX	UNIT	REMARK
LIFE TIME	AOT IF=20mA、Ta=25°C (15000)		--	--	hrs	2).3).
	EL IF=20mA、Ta=25°C (15000)		--	--		

[Note]

1). LED Current measurement method

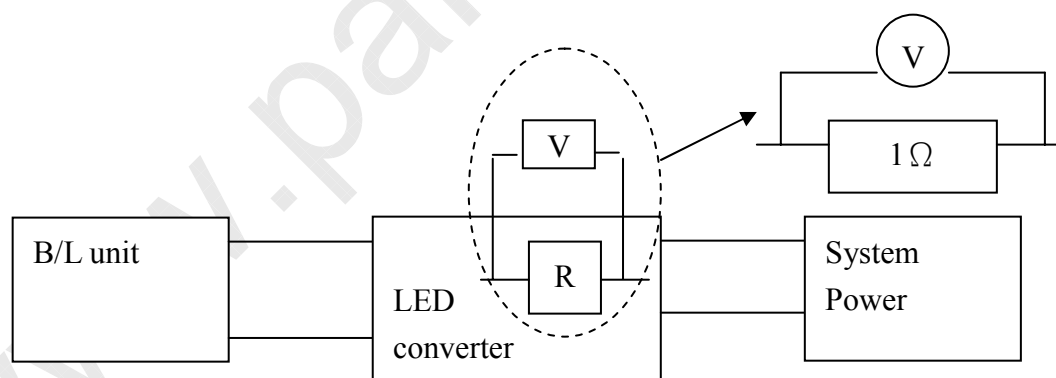

The 1Ω resistance were installed on LED converter. Using by $I=V/R$ can get the LED current.

- 2). Definition of the lamp life time: Luminance (L) under 50% of specification.
- 3). When the ambient temperature T_a overstep 25°C, it will serious damage life time.
- 4). Backlight Power Consumption $W=I_{in} * V_{in}$.

(V_{in} (converter input voltage) =12 V ; I_{in} (converter input current))

CHUNGHWA PICTUER TUBES, LTD.

TECHNICAL SPECIFICATION

Doc. No : _____

Version : AIssue Date : 2008/07/15**Title : CLAA220UA01A Technical Specification****4. INTERFACE PIN CONNECTION**

(1) CN1

Outlet connector: MSCKT2407P30C (STM) (or equivalent)

PIN NO.	REMARK	FUNCTION
1	RXO0-	minus signal of odd channel 0(LVDS)
2	RXO0+	plus signal of odd channel 0(LVDS)
3	RXO1-	minus signal of odd channel 1(LVDS)
4	RXO1+	plus signal of odd channel 1(LVDS)
5	RXO2-	minus signal of odd channel 2(LVDS)
6	RXO2+	plus signal of odd channel 2(LVDS)
7	GND	GND
8	RXOC-	minus signal of odd clock channel (LVDS)
9	RXOC+	plus signal of odd clock channel (LVDS)
10	RXO3-	minus signal of odd channel 3(LVDS)
11	RXO3+	plus signal of odd channel 3(LVDS)
12	RXE0-	minus signal of even channel 0(LVDS)
13	RXE0+	plus signal of even channel 0(LVDS)
14	GND	GND
15	RXE1-	minus signal of even channel 1(LVDS)
16	RXE1+	plus signal of even channel 1(LVDS)
17	GND	GND
18	RXE2-	minus signal of even channel 2(LVDS)
19	RXE2+	plus signal of even channel 2(LVDS)
20	RXEC-	minus signal of even clock channel (LVDS)
21	RXEC+	plus signal of even clock channel (LVDS)
22	RXE3-	minus signal of even channel 3(LVDS)
23	RXE3+	plus signal of even channel 3(LVDS)
24	GND	GND
25	NC	NC
26	NC	Test pin (Can't connect to GND)
27	NC	NC
28	VCC	Power supply input voltage(5.0 V)
29	VCC	Power supply input voltage(5.0 V)
30	VCC	Power supply input voltage(5.0 V)

1) Keep the NC Pin and don't connect it to GND or other signals.

2) GND Pin must connect to the ground, don't let it be a vacant pin.

CHUNGHWA PICTUER TUBES, LTD.

TECHNICAL SPECIFICATION

Doc. No : _____

Version : AIssue Date : 2008/07/15**Title : CLAA220UA01A Technical Specification**

(2) CN2 (BACKLIGHT)

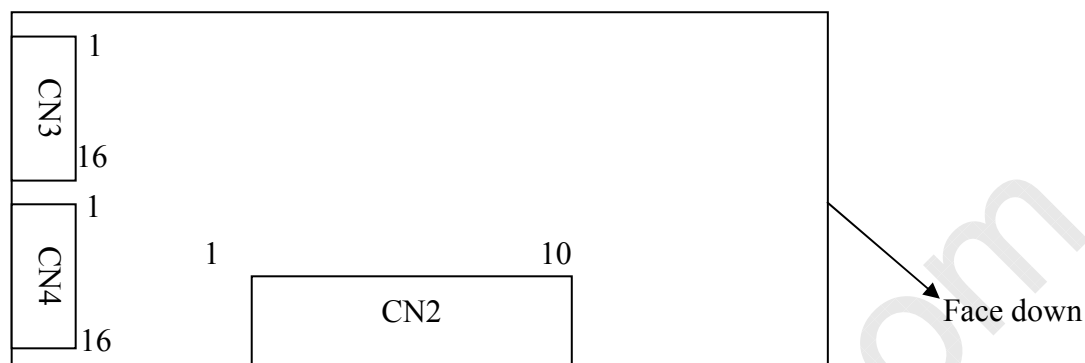

CN2 : CR03-P10H2B-2-E3500 (CONN-TEK) (or equivalent)

<Mating connector: CR03-S10C3 (CONN-TEK) (or equivalent) >

PIN NO.	REMARK	DESCRIPTION
1	Vin	Converter input voltage(12V)
2	Vin	Converter input voltage(12V)
3	Vin	Converter input voltage(12V)
4	Vin	Converter input voltage(12V)
5	Vgnd	Converter ground(Ground)
6	Vgnd	Converter ground(Ground)
7	Vgnd	Converter ground(Ground)
8	Vgnd	Converter ground(Ground)
9	PWMIN	LED Dimming pin
10	EN	Enable pin(3.3V)

CHUNGHWA PICTUER TUBES, LTD.

TECHNICAL SPECIFICATION

Doc. No : _____

Version : AIssue Date : 2008/07/15**Title : CLAA220UA01A Technical Specification****5. INTERFACE TIMING**

(1) Timing Characteristic

ITEM		SYMBOL	MIN.	TYP.	MAX.	UNIT	
LCD Timing	DCLK	Freq.	f_{CLK}	50	73.5	80	MHz
		Cycle	t_{CLK}	12	13.6	16.4	ns
	Horizontal	Horizontal total time	t_H	880	1135	1300	t_{CLK}
		Horizontal effective time	t_{HA}	840	840	840	t_{CLK}
		Horizontal blank time	t_{HB}	40	295	460	t_{CLK}
	Vertical	Vertical frame Rate	Fr	55	60	75	Hz
		Vertical total time	t_V	1060	1080	1300	t_H
		Vertical effective time	t_{VA}	1050	1050	1050	t_H
		Vertical blank time	t_{VB}	10	30	250	t_H

[Note]

- *1) DENA (data enable) usually is positive
- *2) DCLK still inputs during blanking
- *3) DE mode only
- *4) It maybe cause flicker at 55Hz

(2).Timing Chart

a. Horizontal Signal

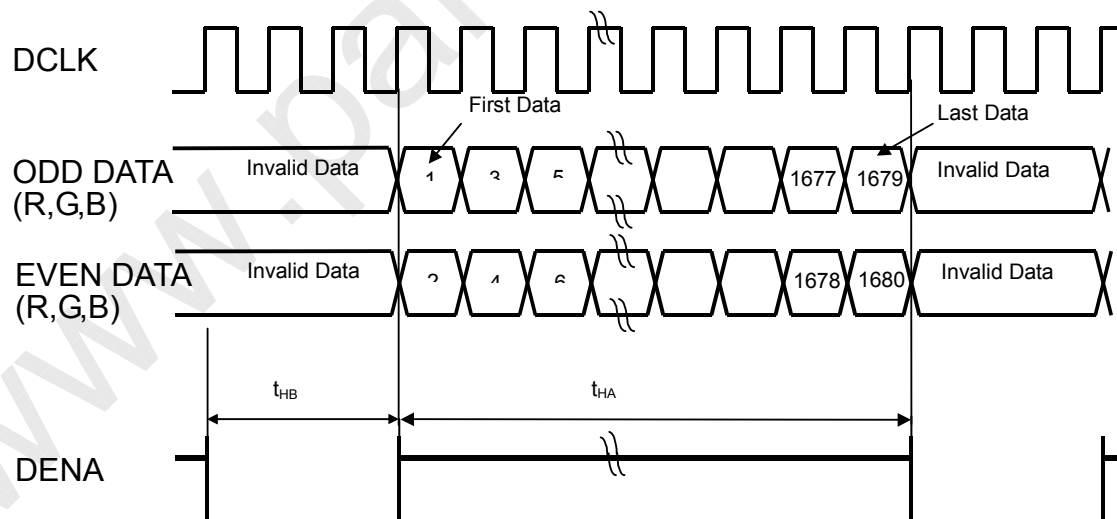

CHUNGHWA PICTUER TUBES, LTD.

TECHNICAL SPECIFICATION

Doc. No : _____
 Version : A
 Issue Date : 2008/07/15

Title : CLAA220UA01A Technical Specification

b. Vertical Signal

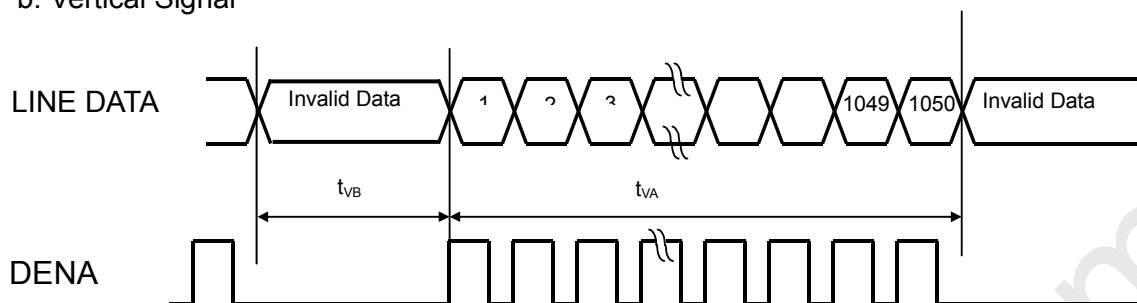

(3).LVDS Data
 For 6Bit+Hi-FRC

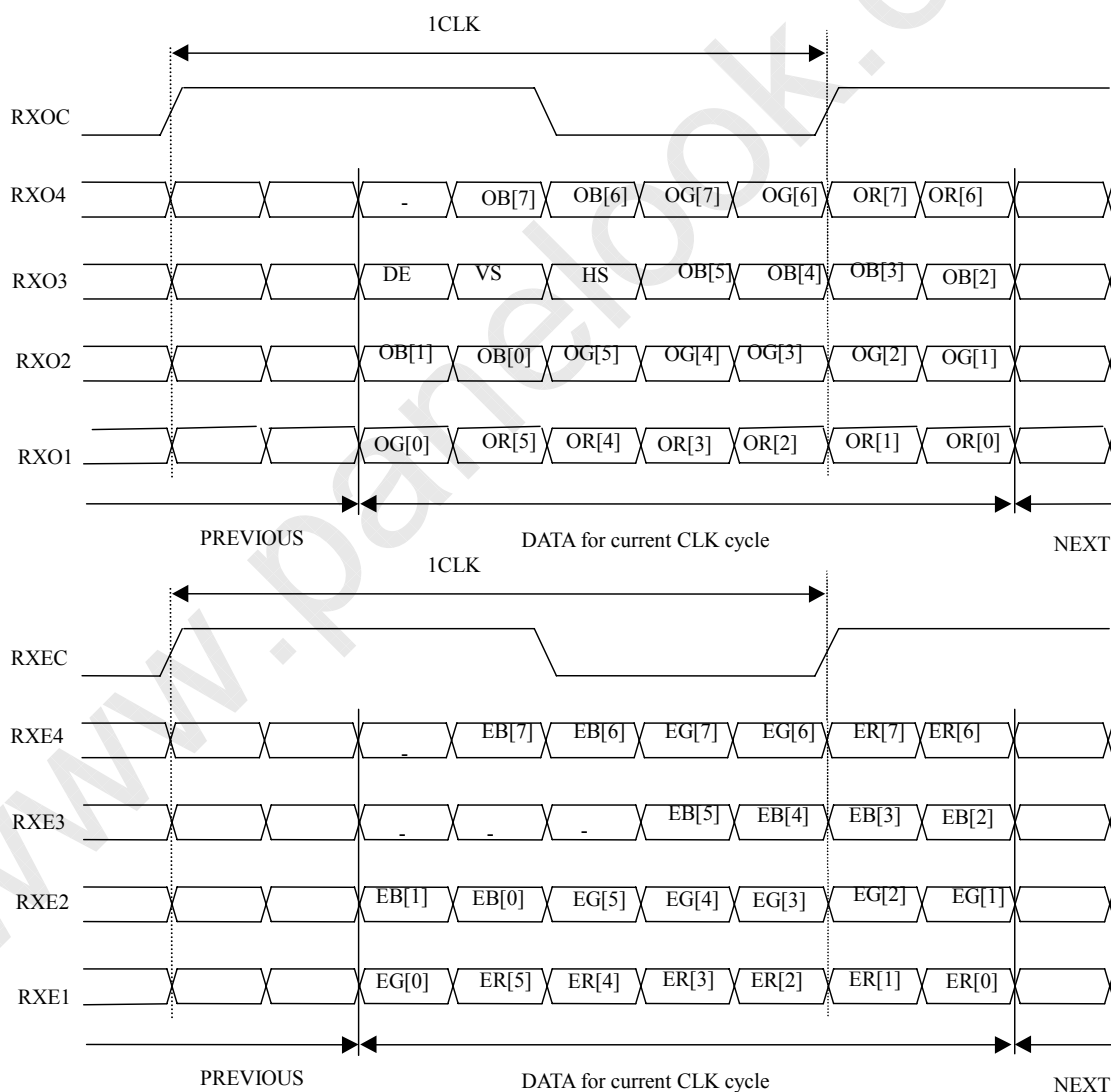

CHUNGHWA PICTUER TUBES, LTD.

TECHNICAL SPECIFICATION

Doc. No : _____
 Version : A
 Issue Date : 2008/07/15

Title : CLAA220UA01A Technical Specification

Color Data Assignment

COLOR	INPUT DATA	R DATA								G DATA								B DATA															
		R7	R6	R5	R4	R3	R2	R1	R0	G7	G6	G5	G4	G3	G2	G1	G0	B7	B6	B5	B4	B3	B2	B1	B0								
		MSB								LSB								MSB								LSB							
BASIC COLOR	BLACK	0	0	0	0	0	0	0	0	0	0	0	0	0	0	0	0	0	0	0	0	0	0	0	0								
	RED(255)	1	1	1	1	1	1	1	1	0	0	0	0	0	0	0	0	0	0	0	0	0	0	0									
	GREEN(255)	0	0	0	0	0	0	0	0	1	1	1	1	1	1	1	0	0	0	0	0	0	0	0									
	BLUE(255)	0	0	0	0	0	0	0	0	0	0	0	0	0	0	0	1	1	1	1	1	1	1	1									
	CYAN	0	0	0	0	0	0	0	0	1	1	1	1	1	1	1	1	1	1	1	1	1	1	1									
	MAGENTA	1	1	1	1	1	1	1	1	0	0	0	0	0	0	0	1	1	1	1	1	1	1	1									
	YELLOW	1	1	1	1	1	1	1	1	1	1	1	1	1	1	1	0	0	0	0	0	0	0	0									
	WHITE	1	1	1	1	1	1	1	1	1	1	1	1	1	1	1	1	1	1	1	1	1	1	1									
RED	RED(0)	0	0	0	0	0	0	0	0	0	0	0	0	0	0	0	0	0	0	0	0	0	0										
	RED(1)	0	0	0	0	0	0	0	1	0	0	0	0	0	0	0	0	0	0	0	0	0	0										
	RED(2)	0	0	0	0	0	0	1	0	0	0	0	0	0	0	0	0	0	0	0	0	0	0										
	RED(254)	1	1	1	1	1	1	1	0	0	0	0	0	0	0	0	0	0	0	0	0	0	0										
	RED(255)	1	1	1	1	1	1	1	0	0	0	0	0	0	0	0	0	0	0	0	0	0	0										
GREEN	GREEN(0)	0	0	0	0	0	0	0	0	0	0	0	0	0	0	0	0	0	0	0	0	0	0										
	GREEN(1)	0	0	0	0	0	0	0	0	0	0	0	0	0	1	0	0	0	0	0	0	0	0										
	GREEN(2)	0	0	0	0	0	0	0	0	0	0	0	0	1	0	0	0	0	0	0	0	0	0										
	GREEN(254)	0	0	0	0	0	0	0	1	1	1	1	1	1	0	0	0	0	0	0	0	0	0										
	GREEN(255)	0	0	0	0	0	0	0	1	1	1	1	1	1	1	0	0	0	0	0	0	0	0										
BLUE	BLUE(0)	0	0	0	0	0	0	0	0	0	0	0	0	0	0	0	0	0	0	0	0	0	0										
	BLUE(1)	0	0	0	0	0	0	0	0	0	0	0	0	0	0	0	0	0	0	0	0	0	1										
	BLUE(2)	0	0	0	0	0	0	0	0	0	0	0	0	0	0	0	0	0	0	0	0	1	0										
	BLUE(254)	0	0	0	0	0	0	0	0	0	0	0	0	0	0	1	1	1	1	1	1	1	0										
	BLUE(255)	0	0	0	0	0	0	0	0	0	0	0	0	0	0	1	1	1	1	1	1	1	1										

- [Note] 1) Definition of gray scale: Color (n): n indicates gray scale level; higher n means brighter level.
 2) Data: 1-High, 0-Low.
 3) For odd & even data also.

(4).Color Data Distribution

D(1,1)	D(2,1)	..	D(X,1)	..	D(1679,1)	D(1680,1)
D(1,2)	D(2,2)	..	D(X,2)	..	D(1679,2)	D(1680,2)
..	..	+	..	+
D(1,Y)	D(2,Y)	..	D(X,Y)	..	D(1679,Y)	D(1680,Y)
..	..	+	..	+
D(1,1049)	D(2,1049)	..	D(X,1049)	..	D(1679,1049)	D(1680,1049)
D(1,1050)	D(2,1050)	..	D(X,1050)	..	D(1679,1050)	D(1680,1050)

CHUNGHWA PICTUER TUBES, LTD.

TECHNICAL SPECIFICATION

Doc. No : _____

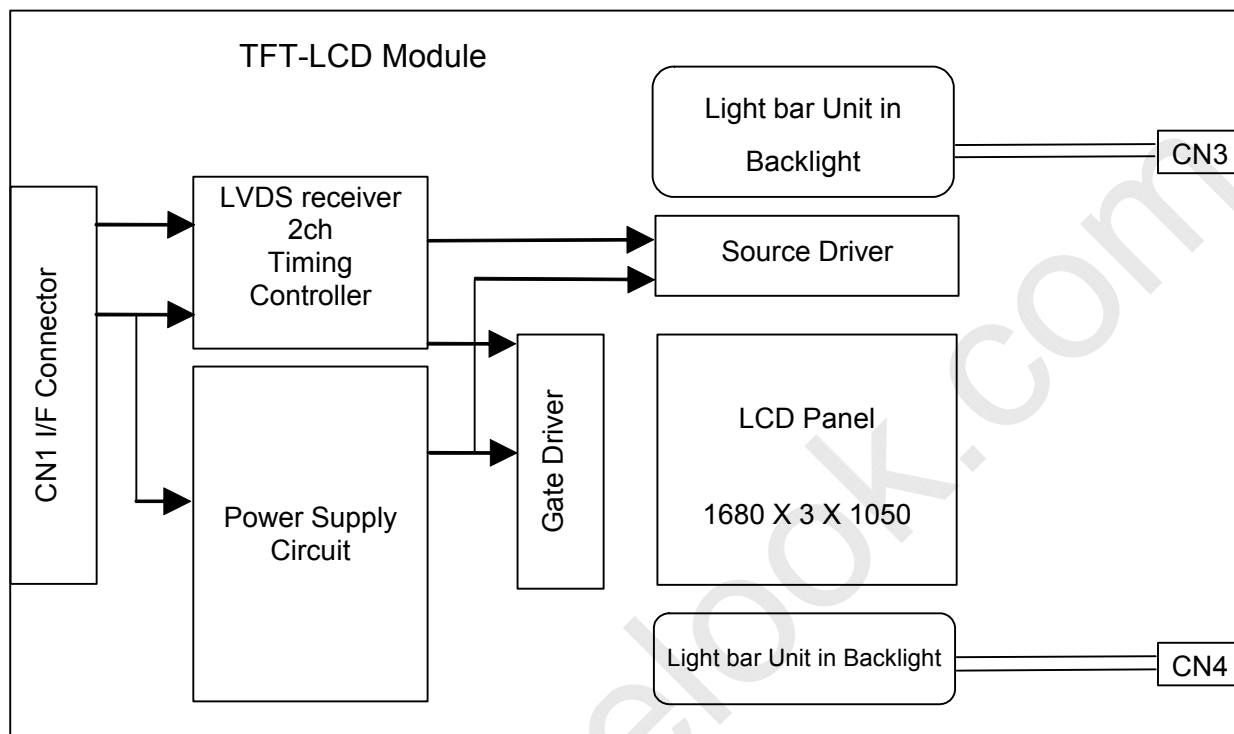
Version : AIssue Date : 2008/07/15**Title : CLAA220UA01A Technical Specification****6. BLOCK DIAGRAM**

Light bar Unit in Backlight

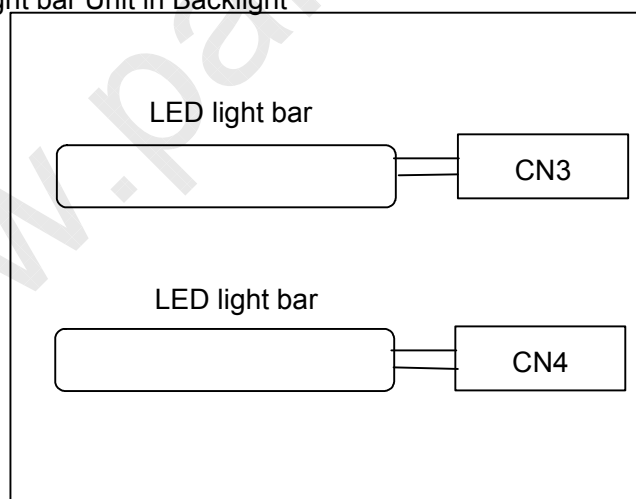



CHUNGHWA PICTUER TUBES, LTD.

TECHNICAL SPECIFICATION

Doc. No : _____
Version : A
Issue Date : 2008/07/15

Title : CLAA220UA01A Technical Specification

7. MECHANICAL SPECIFICATION

(1) Front side (Tolerance is ± 0.5mm unless noted)

[Unit:mm]

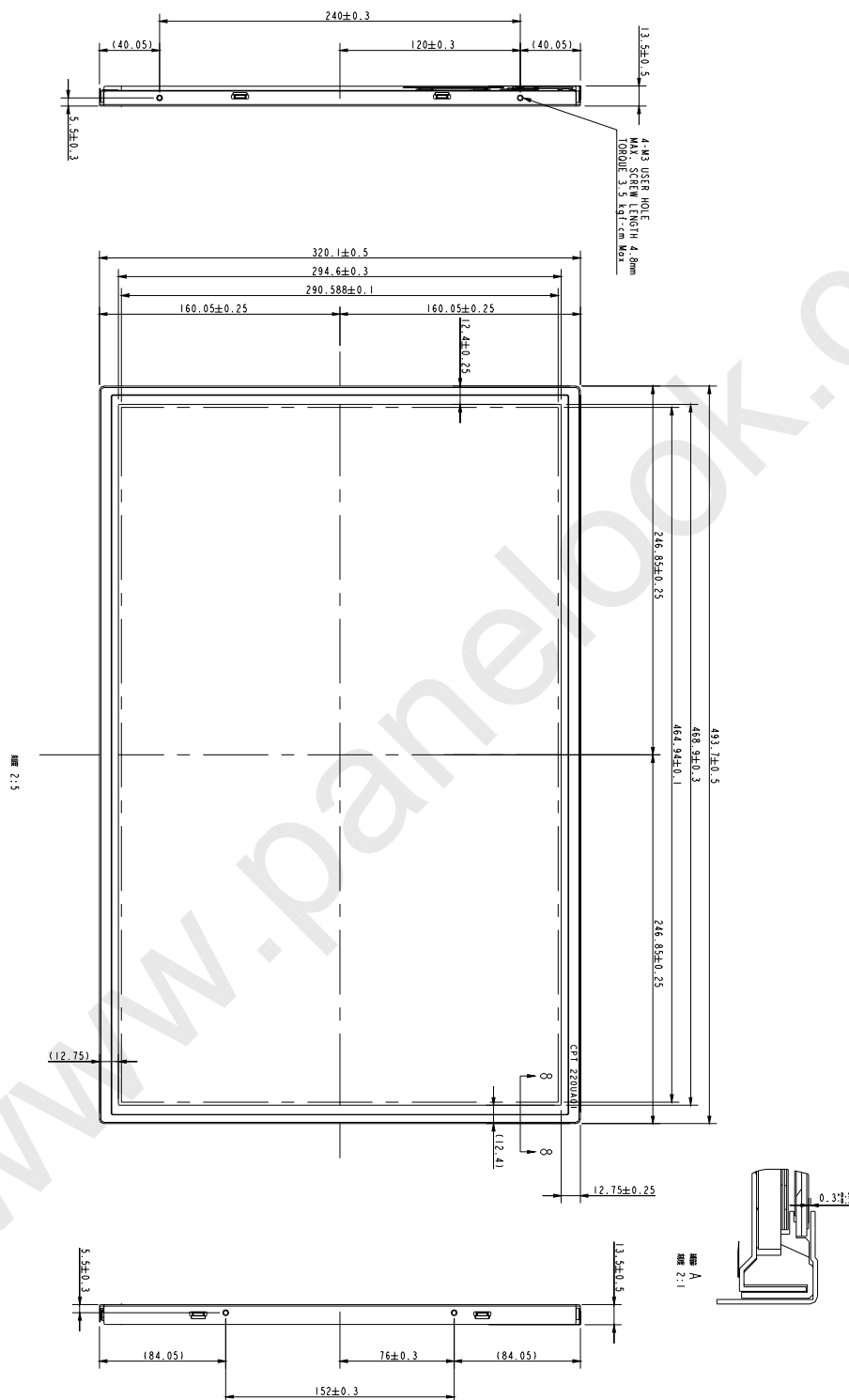



CHUNGHWA PICTUER TUBES, LTD.

TECHNICAL SPECIFICATION

Doc. No : _____

Version : A

Issue Date : 2008/07/15

Title : CLAA220UA01A Technical Specification

(2)Rear side (Tolerance is ±0.5mm unless noted)

[Unit: mm]

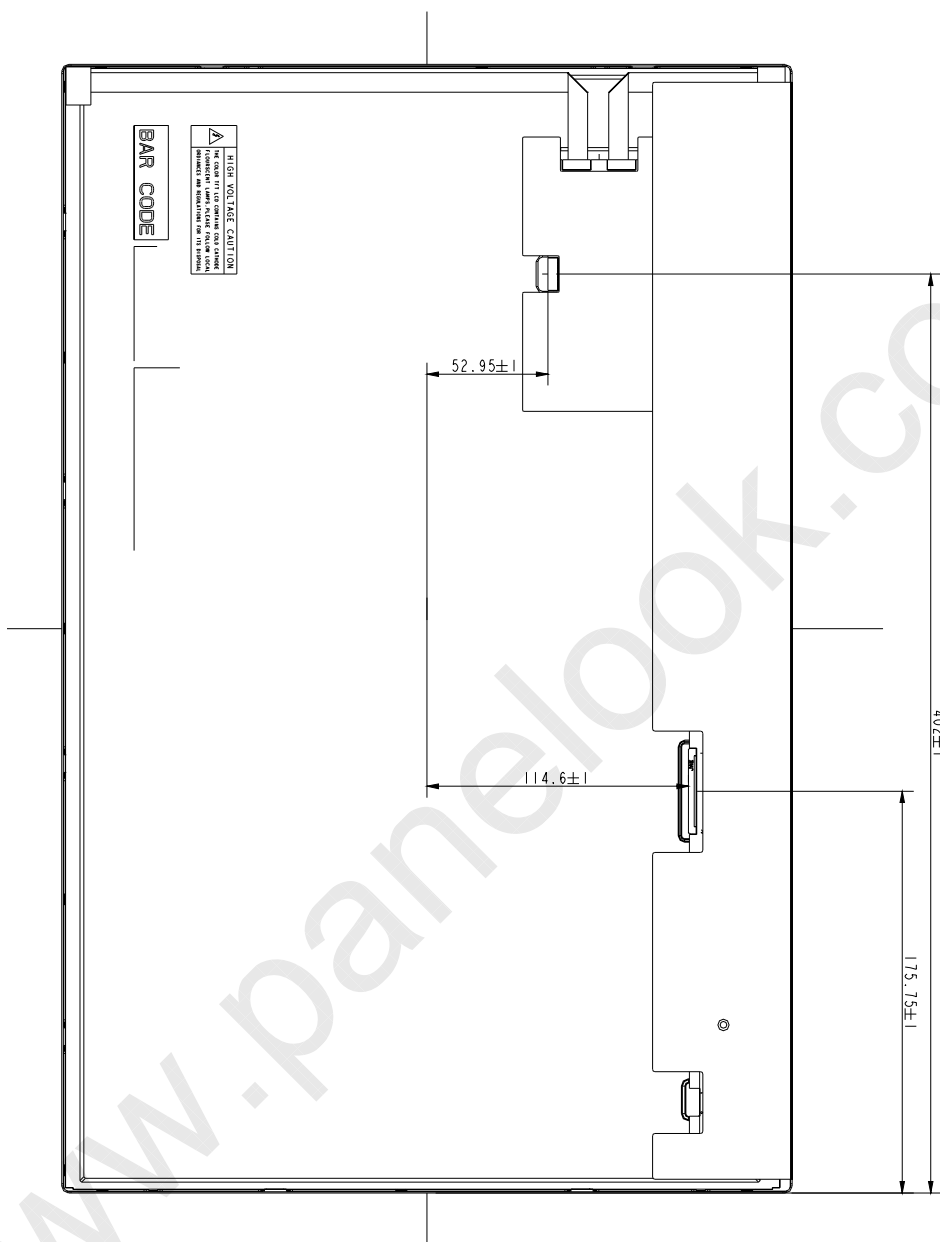

CHUNGHWA PICTUER TUBES, LTD.

TECHNICAL SPECIFICATION

Doc. No : _____

Version : AIssue Date : 2008/07/15**Title : CLAA220UA01A Technical Specification****8. OPTICAL CHARACTERISTICS**

Ta=25°C , VCC=5.0V

ITEM	SYMBOL	CONDITION	MIN.	TYP.	MAX.	UNIT	REMARK	
Contrast (CEN)	CR	$\theta=\psi= 0^\circ$		1000	--	--	*1) 2)	
Luminance (CEN)	L	$\theta=\psi= 0^\circ$		(280)	--	cd/m ²	*1) 3)	
9P Uniformity	ΔL	$\theta=\psi= 0^\circ$	75	--	--	%	*1) 3)	
Response Time	Tr+Tf	$\theta=\psi= 0^\circ$	--	5	8	ms	*5)	
Cross talk	CT	$\theta=\psi= 0^\circ$	--	--	1	%	*6)	
View angle	Horizontal	ψ	$CR \geq 10$	75/-75	85/-85	--	Deg.	*4)
	Vertical	θ		75/-65	85/-75	--	Deg.	
	Horizontal	ψ	$CR \geq 5$	75/-75	85/-85	--	Deg.	
	Vertical	θ		75/-75	85/-85	--	Deg.	
Color Coordinates	White	x	$\theta=\psi= 0^\circ$	0.283	0.313	0.343	Color Coordinates	*3)
		y		0.299	0.329	0.359		
	Red	x		(0.608)	(0.638)	(0.668)		
		y		(0.323)	(0.353)	(0.383)		
	Green	x		(0.306)	(0.336)	(0.366)		
		y		(0.588)	(0.618)	(0.648)		
Blue	x	(0.115)	(0.145)	(0.175)				
	y	(0.018)	(0.048)	(0.078)				
Gamut	CG	$\theta=\psi= 0^\circ$	--	70	--	%		
Gamma	γ	VESA	2.0	2.2	2.4	--	*7)	

[Note]

Color coordinate and color gamut are measured by CS-1000, and all the other items are measured by BM-5A (TOPCON). All these items are measured under the dark room condition (no ambient light).

Measurement Condition: IL=7.5mA × 4

Inverter: Sumida, model: TWS-400-9656 — — , Frequency=50kHz.

Definition of these measurement items is as follows:

1) Setup of Measurement Equipment

The LCD module should be turn-on to a stable luminance level to be reached. The measurement should be executed after lighting Backlight for 20 minutes and in a dark room.

CHUNGHWA PICTUER TUBES, LTD.

TECHNICAL SPECIFICATION

Doc. No : _____

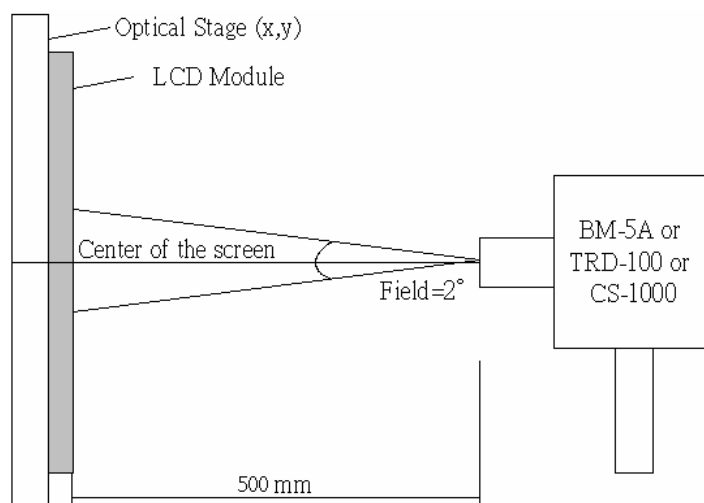
Version : A Issue Date : 2008/07/15 **Title : CLAA220UA01A Technical Specification**

2) Definition of Contrast Ratio

$$CR = \text{ON (White) Luminance} / \text{OFF (Black) Luminance}$$

3) Definition of Luminance and Luminance uniformity

Central luminance: The white luminance is measured at the center position "5" on the screen, see Fig.1 below. And the measure time is 30 min after discharged.

9P Luminance (AVG): The white luminance is measured at measuring points 1 to 9, see Fig.1 below.

9P Uniformity: $\Delta L = (L_{\text{MIN}} / L_{\text{MAX}}) \times 100\%$

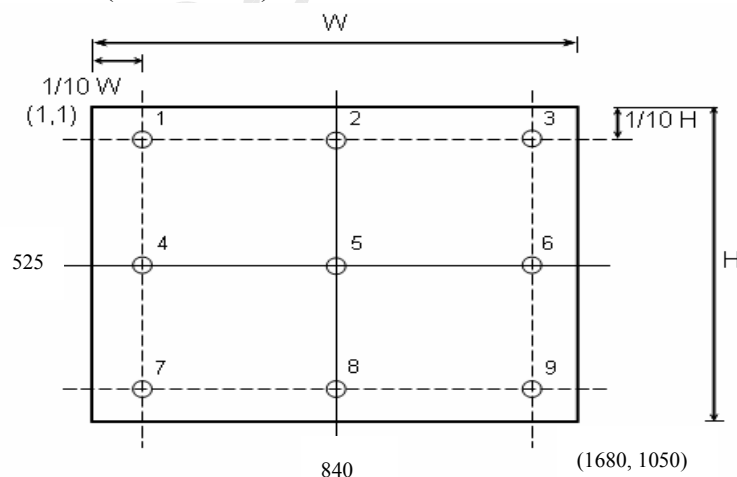

CHUNGHWA PICTUER TUBES, LTD.

TECHNICAL SPECIFICATION

Doc. No : _____
 Version : A
 Issue Date : 2008/07/15

Title : CLAA220UA01A Technical Specification

4).Definition of Viewing Angle (θ, ψ):

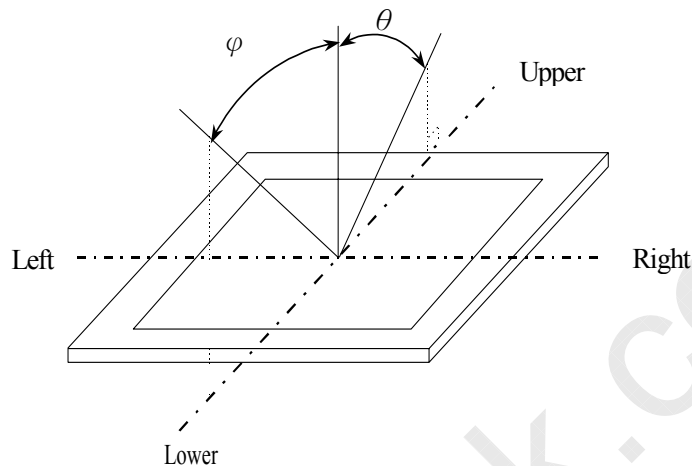

5) Definition of Response Time:

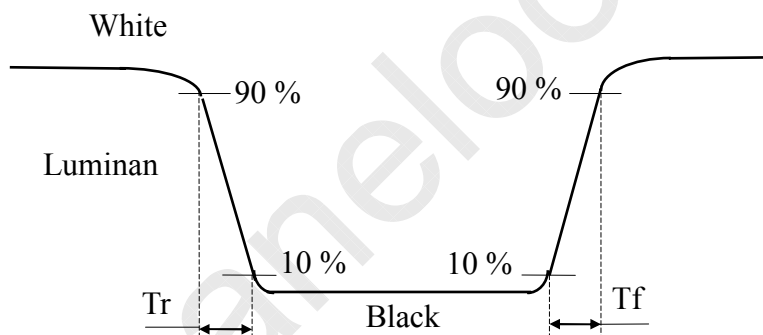

6) Definition of crosstalk:

$$CT = | Y_B - Y_A | / Y_A \times 100 (\%)$$

Y_A : The luminance of measured position at pattern A

Y_B : The luminance of measured position at pattern B with Gray level 0

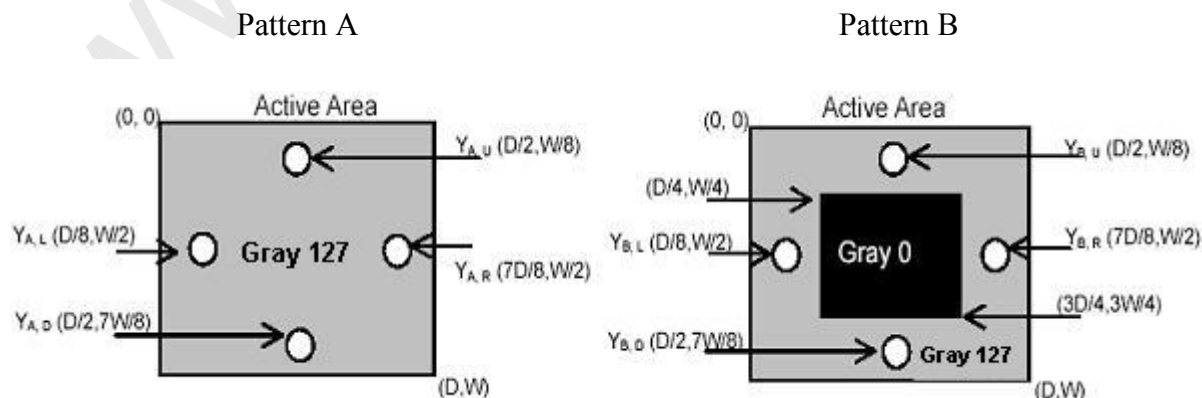

CHUNGHWA PICTUER TUBES, LTD.

TECHNICAL SPECIFICATION

Doc. No : _____

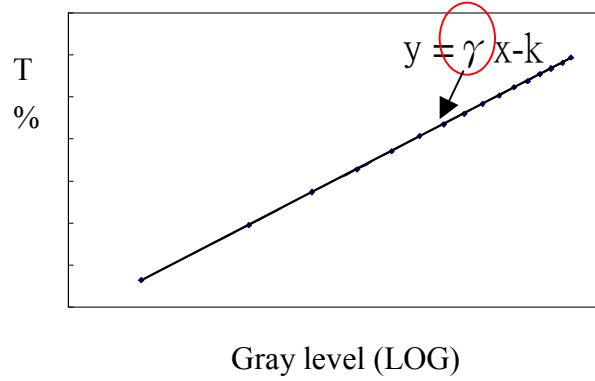
Version : AIssue Date : 2008/07/15**Title : CLAA220UA01A Technical Specification**7) Definition of Gamma (γ), follow VESA standard sampling every 16 gray level (0,16,32,.....224,240,255)

CHUNGHWA PICTUER TUBES, LTD.

TECHNICAL SPECIFICATION

Doc. No : _____

Version : AIssue Date : 2008/07/15**Title : CLAA220UA01A Technical Specification****9. RELIABILITY TEST CONDITIONS**

(1) Temperature and Humidity

TEST ITEMS	CONDITIONS
HIGH TEMPERATURE HIGH HUMIDITY OPERATION	50°C ; 90%RH; 240h (No condensation)
HIGH TEMPERATURE HIGH HUMIDITY STORAGE	60°C ; 90%RH; 48h (No condensation)
HIGH TEMPERATURE OPERATION	50°C ; 240h
HIGH TEMPERATURE STORAGE	60°C ; 240h
LOW TEMPERATURE OPERATION	0°C ; 240h
LOW TEMPERATURE STORAGE	-20°C ; 240h
THERMAL SHOCK	BETWEEN -20°C (1hr)AND 60°C (1hr); 100 CYCLES

(2) Shock & Vibration

ITEMS	CONDITIONS
SHOCK (NON-OPERATION)	Shock level:980m/s ² (100G) Waveform: half sinusoidal wave, 2ms Number of shocks: one shock input in each direction of three mutually perpendicular axes for a total of six shock inputs
VIBRATION (NON-OPERATION)	Vibration level: 9.8m/s ² (1.0G) zero to peak Waveform: sinusoidal Frequency range: 5 to 500 Hz Frequency sweep rate: 0.5 octave/min Duration: one sweep from 5 to 500Hz in each of three mutually perpendicular axis(each x,y,z axis: 1 hour, total 3 hours)

(3) ESD

POSITION	CONDITION(MDL turn off)
Connector	1. 200 pF , 0 Ω , ±250 V 2. contact mode for each pin
Module	1. 150 pF , 330 Ω , ±15K V 2. Air mode, test 25 times for each test point 3. Contact mode, 25 times for each test point

(4) Low Pressure test

TEST ITEM	CONDITION
Low Pressure test(storage)	260HPa (30000 ft.) ; 24 Hr

CHUNGHWA PICTUER TUBES, LTD.

TECHNICAL SPECIFICATION

Doc. No : _____
 Version : A
 Issue Date : 2008/07/15

Title : CLAA220UA01A Technical Specification

(5) Judgment standard

The judgment of the above test should be made as follow:

Pass: Normal display image with no obvious non-uniformity and no line defect. Partial transformation of the module parts should be ignored.

Fail: No display image, obvious non-uniformity, or line defects.

10. DESIGNATION OF LOT MARK

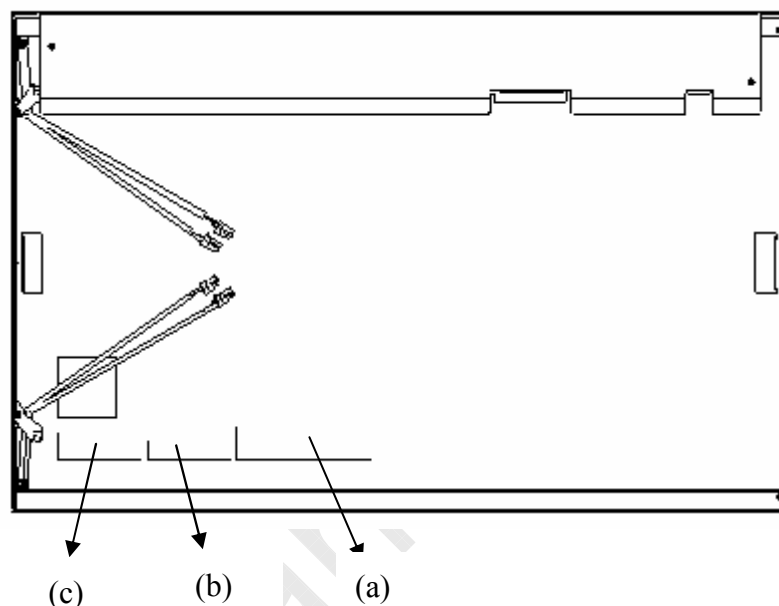

(a) 4_IN_1 LABEL: (Model Name: CLAA220UA01A)



A	B	C	D	E	F	G	H	I
---	---	---	---	---	---	---	---	---

CHUNGHWA PICTUER TUBES, LTD.

TECHNICAL SPECIFICATION

Doc. No : _____

Version : AIssue Date : 2008/07/15**Title : CLAA220UA01A Technical Specification**

A : Year

B、C : Week

D、E、F、G、H : Serial No.

I : Factory Code

[Note]

(1) Year

Year	2000	2001	2002	2003	2004	2005	2006	2007	2008	2009
Mark	0	1	2	3	4	5	6	7	8	9

(2) Week

Week	1	2	3	4	5	6	7	8	9	10	11	12
Mark	01	02	03	04	05	06	07	08	09	10	11	12

(3) Serial No.

Serial No.	1~99,999
Mark	00001~99999

(4) Factory Code

Factory Code	T2 Factory	L Factory	WJ1 Factory	WJ2 Factory	WJ3 Factory	SDT Factory	FDT Factory	CTOC Factory
Mark	R	S	U	V	A	Z	F	Q

(b) PANEL LABEL :



(c) B/L MAKER LABEL : (R220UA01xxxxxxxxxxxxxxxxxxxxxx)

R220UA01xxxxxxxxxxxxxxxxxxxxxx

(2) Location of Lot Mark

The label is attached to the backside of the LCD Module. This is subject to change without prior notice.

CHUNGHWA PICTUER TUBES, LTD.

TECHNICAL SPECIFICATION

Doc. No : _____

Version : AIssue Date : 2008/07/15**Title : CLAA220UA01A Technical Specification****11. PACKING SPECIFICATION****(1)Packing**

- 7 LCD IT modules (max.) / 1 Box
- 24 box (max.) / 1 pallet
- Box dimensions: 564(L)×244(W)×412(H)
- Weight: approximately 14.7Kg (7 modules per box)

(2)Packing Method

Figure (a) and (b) are the packing method

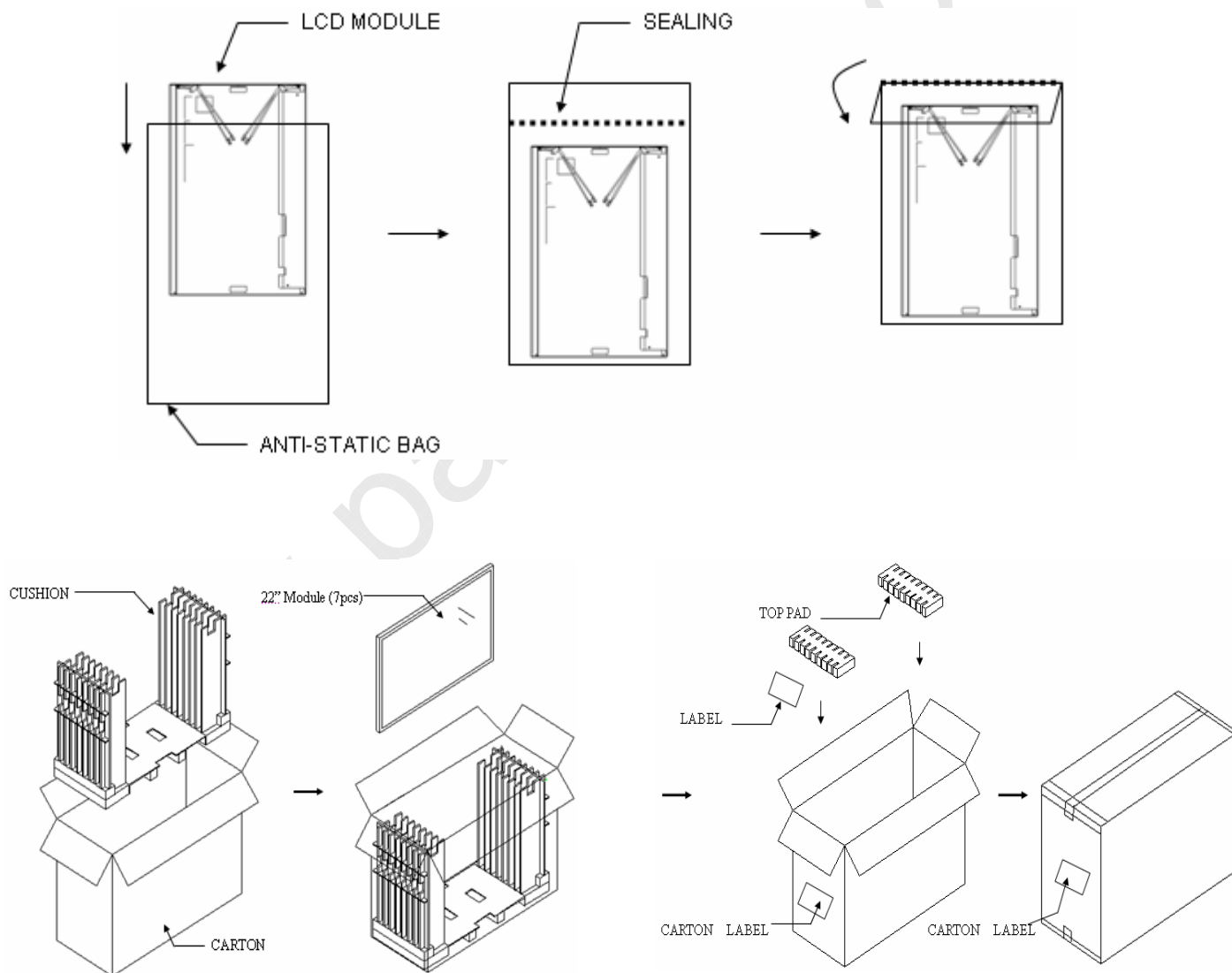

Figure (a) packing method

CHUNGHWA PICTUER TUBES, LTD.

TECHNICAL SPECIFICATION

Doc. No : _____

Version : AIssue Date : 2008/07/15**Title : CLAA220UA01A Technical Specification**

Cover Protector: L1230 × 50 × 50mm

Pallet: 1150(L) × 1000(W) × 130(H) mm

Top/Bottom Cap: L1150 × 1000 × 130mm

Pallet stack: 1150(L) × 1000(W) × 1386(H) mm

Gross Weight: 363Kg(±2Kg)

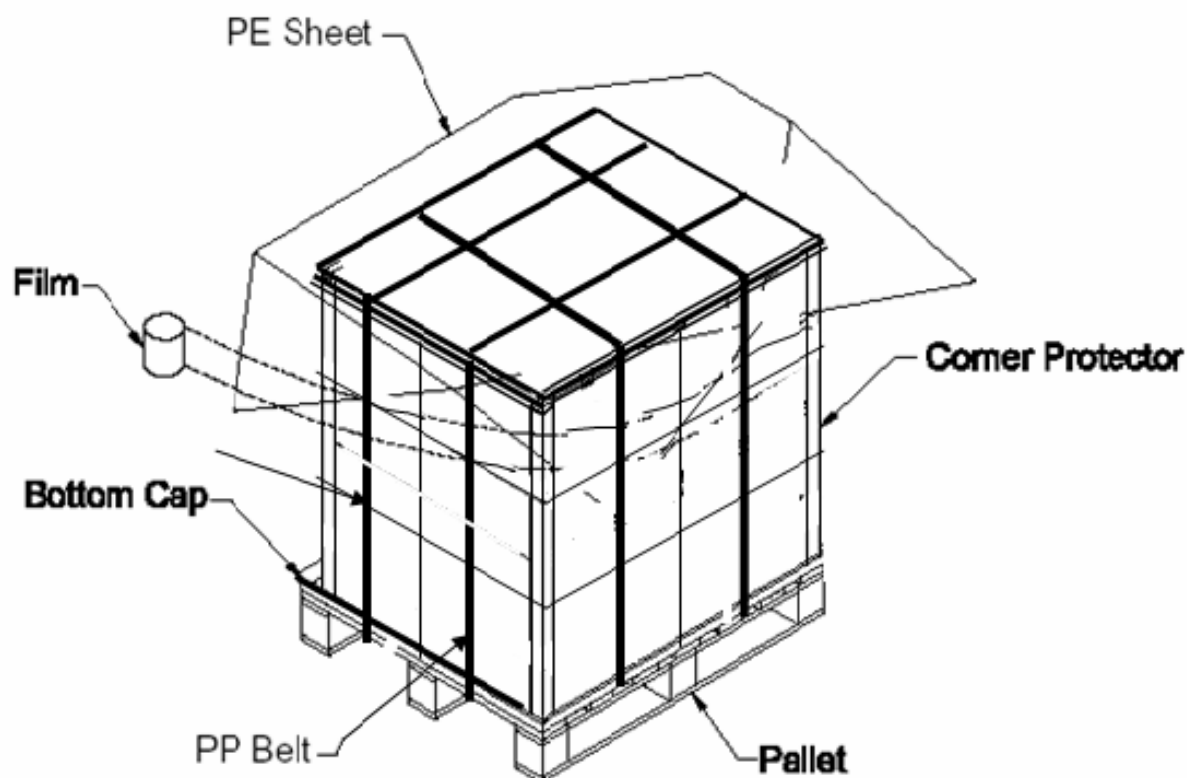

Figure (b) packing method

CHUNGHWA PICTUER TUBES, LTD.

TECHNICAL SPECIFICATION

Doc. No : _____

Version : AIssue Date : 2008/07/15**Title : CLAA220UA01A Technical Specification**

12. HANDLING PRECAUTIONS FOR TFT-LCD MODULE

Please pay attention to the followings in handling- TFT-LCD products;

1. ASSEMBLY PRECAUTION

- (1) Please use the mounting hole on the module side in installing and do not beading or wrenching LCD in assembling. And please do not drop, bend or twist LCD module in handling.
- (2) Please design display housing in accordance with the following guide lines.
 - (2.1) Housing case must be destined carefully so as not to put stresses on LCD all sides and not to wrench module. The stresses may cause non-uniformity even if there is no non-uniformity statically.
 - (2.2) Keep sufficient clearance between LCD module back surface and housing when the LCD module is mounted. Approximately 1.0 mm of the clearance in the design is recommended taking into account the tolerance of LCD module thickness and mounting structure height on the housing.
 - (2.3) When some parts, such as, FPC cable and ferrite plate, are installed underneath the LCD module, still sufficient clearance is required, such as 0.5mm. This clearance is, especially, to be reconsidered when the additional parts are implemented for EMI countermeasure.
 - (2.4) Design the inverter location and connector position carefully so as not to give stress to lamp cable, or not to interface the LCD module by the lamp cable.
 - (2.5) Keep sufficient clearance between LCD module and the others parts, such as inverter and speaker so as not to interface the LCD module. Approximately 1.0mm of the clearance in the design is recommended.
- (3) Please do not push or scratch LCD panel surface with any-thing hard. And do not soil LCD panel surface by touching with bare hands. (Polarizer film, surface of LCD panel is easy to be flawed.)
- (4) Please do not press any parts on the rear side such as source TCP, gate TCP, control circuit board and FPCs during handling LCD module. If pressing rear part is unavoidable, handle the LCD module with care not to damage them.
- (5) Please wipe out LCD panel surface with absorbent cotton or soft cloth in case of it being soiled.
- (6) Please wipe out drops of adhesives like saliva and water on LCD panel surface immediately. They might damage to cause panel surface variation and color change.
- (7) Please do not take a LCD module to pieces and reconstruct it. Resolving and

CHUNGHWA PICTUER TUBES, LTD.

TECHNICAL SPECIFICATION

Doc. No : _____

Version : AIssue Date : 2008/07/15**Title : CLAA220UA01A Technical Specification**

reconstructing modules may cause them not to work well.

- (8) Please do not touch metal frames with bare hands and soiled gloves. A color change of the metal frames can happen during a long preservation of soiled LCD modules.
- (9) Please pay attention to handling lead wire of backlight so that it is not tugged in connecting wit inverter.

2. OPERATING PRECAUTIONS

- (1) Please be sure to turn off the power supply before connecting and disconnecting signal input cable.
- (2) Please do not change variable resistance settings in LCD module. They are adjusted to the most suitable value. If they are changed, it might happen LCD does not satisfy the characteristics specification.
- (3) Please consider that LCD backlight takes longer time to become stable of radiation characteristics in low temperature than in room temperature.
- (4) A condensation might happen on the surface and inside of LCD module in case of sudden change of ambient temperature.
- (5) Please pay attention to displaying the same pattern for very long time. Image might stick on LCD. If then, time going on can make LCD work well.
- (6) Please obey the same caution descriptions as ones that need to pay attention to ordinary electronic parts.

3. PRECAUTIONS WITH ELECTROSTATICS

- (1) This LCD module use CMOS-IC on circuit board and TFT-LCD panel, and so it is easy to be affected by electrostatics. Please be careful with electrostatics by the way of your body connecting to the ground and so on.
- (2) Please remove protection film very slowly on the surface of LCD module to prevent from electrostatics occurrence.

4. STORAGE PRECAUTIONS

- (1) When you store LCDs for a long time, it is recommended to keep the temperature between 0°C ~40°C without the exposure of sunlight and to keep the humidity less than 90%RH.
- (2) Please do not leave the LCDs in the environment of high humidity and high temperature such as 60°C 90%RH.
- (3) Please do not leave the LCDs in the environment of low temperature; below -20°C.

CHUNGHWA PICTUER TUBES, LTD.

TECHNICAL SPECIFICATION

Doc. No : _____

Version : AIssue Date : 2008/07/15**Title : CLAA220UA01A Technical Specification**

5. SAFETY PRECAUTIONS

- (1) When you waste LCDS, it is recommended to crush damaged or unnecessary LCDs into pieces and wash them off with solvents such as acetone and ethanol, which should later be burned.
- (2) If any liquid leaks out of a damaged-glass cell and comes in contact with the hands, wash off thoroughly with soap and water.

6. OTHERS

- (1) A strong incident light into LCD panel might cause display characteristics' changing inferior because of polarizer film, color filter, and other materials becoming inferior. Please do not expose LCD module direct sunlight and strong UV rays.
- (2) Please pay attention to a panel side of LCD module not to contact with other materials in preserving it alone.
- (3) For the packaging box, please pay attention to the followings:
 - (3.1) Packaging box and inner case for LCD are designed to protect the LCDs from the damage or scratching during transportation. Please do not open except picking LCDs up from the box.
 - (3.2) Please do not pile them up more than 5 boxes. (They are not designed so.) And please do not turn over.
 - (3.3) Please handle packaging box with care not to give them sudden shock and vibrations. And also please do not throw them up.
 - (3.4) Packing box and inner case for LCDs are made of cardboard. So please pay attention not to get them wet. (Such like keeping them in high humidity or wet place can occur getting them wet.)