



Chunghwa Picture Tubes, Ltd.

Technical Specification

To	: AMCOM TECHNOLOGY INC.
Date	: 2009.11.11

CPT TFT-LCD

CLAA315WA01

ACCEPTED BY:

APPROVED BY	CHECKED BY	PREPARED BY
周廷縣	林永池	Product Planning Management General Division

Prepared by : Design General Division

CHUNGHWA PICTUER TUBES, LTD.

1127 Hopin Rd., Padeh, Taoyuan, Taiwan 334, R.O.C.
TEL: +886-3-3675151 FAX: +886-3-377-3001

Doc. No:	CLAA315WA01-SPEC-Eternal-V1-20091111	Issue Date:	2009.11.11
----------	--------------------------------------	-------------	------------

Title : CLAA315WA01 Technical Specification

RECORD OF REVISIONS

NO.	Issue Date	Modification Index	Modifier
1	Dec.08,2008	Preliminary Specification (First Draft)	

Title : CLAA315WA01 Technical Specification

CONTENTS

項次	Table of Content	page
1	OVERVIEW	4
2	ABSOLUTE MAXIMUM RATINGS	5
3	ELECTRICAL CHARACTERISTICS	6
4	INTERFACE PIN CONNECTION	12
5	INTERFACE TIMING	16
6	BLOCK DIAGRAM	18
7	MECHANICAL SPECIFICATION	19
8	OPTICAL CHARACTERISTICS	21
9	RELIABILITY TEST CONDITIONS	27

Title : CLAA315WA01 Technical Specification**1. OVERVIEW**

CLAA315WA01 is 31.5" color (80.04cm) TFT-LCD (Thin Film Transistor Liquid Crystal Display) module composed of LCD panel, LVDS driver ICs, control circuit and backlight. By applying 8 bit digital data, 1366*768, 16.7 million-color images are displayed on the 31.5" diagonal screen .Inverter for backlight is included in this module. General specifications are summarized in the following table:

Item		Specification	Unit
Display Area		697.648(H) × 392.256(V) (31.51 inch diagonal)	mm
Number of Pixels		1366(H) × 768(V)	16:9
Pixel Pitch		0.51075(H) × 0.51075(V)	mm
Bezel Opening Area		703.6 x 398.4	mm
Color Pixel Arrangement		RGB Vertical Strip	
Display Mode		Normally Black	
Number of Colors		16.7M (8bits)	color
Wide View Tech.		E-MVA	
Electrical Interface		LVDS	
Total Module Power		65 (Typ.) (B/L with inverter 58W)	W
Module Outline Dimension	Horizontal(H)		760 (Typ)
	Vertical(V)		450 (Typ)
	Depth(D)	without inverter	30.8 (Typ)
		with inverter	45 (Typ)
Module Weight		6200 (Typ)	g
Backlight Unit		4U-CCFL	
Surface Treatment		Hard coating , Anti-glare , Surface-hardness : 3H (Reflection : 4%)	

The LCD products listed on this document are not suitable for use of aerospace equipment, submarine cables, and nuclear reactor control system and life support systems. If customers intend to use these LCD products for above application or not listed in "Standard" as follows, please contact our sales people in advance.

Standard : Computer, Office equipment, Communication equipment, Test and Measurement equipment, Machine tool, Industrial robot, Audio and Visual equipment, Other consumer products.

Title : CLAA315WA01 Technical Specification

2. ABSOLUTE MAXIMUM RATINGS

The following are maximum values which, if exceeded, may cause faulty operation or damage to the Unit.

Item	Symbol	Min.	Max.	Unit	Note
Power Supply Voltage For LCD	VCC	-0.3	14.0	V	
Input voltage of inverter	VBL	-0.3	27	V	
Inverter dimming	VDIM	-0.3	3.5	Vdc	
Backlight on/off	VBLON	-0.3	5.5	Vdc	
ESD for Connector	VESD	-250	250	V	
ESD for Module	VESD	-15	15	KV	
Operation Ambient Temperature	T _{op}	0	50	°C	*1) *2) *3)
Storage Temperature	T _{stg}	-20	60	°C	*1) *2)

[Note 1] The relative temperature and humidity range are as below sketch

Humidity \leq 85%RH without condensation .Relative

Humidity \leq 90% (Ta \leq 40°C) , Wet Bulb Temperature \leq 39°C (Ta \geq 40°C)

[Note 2] If you use the product in an environment which's over the definition of temperature and humidity too long , it will effect the result of visual inspection.

[Note 3] If you operate the product in normal temperature range, the center surface of panel should be under 60°C .

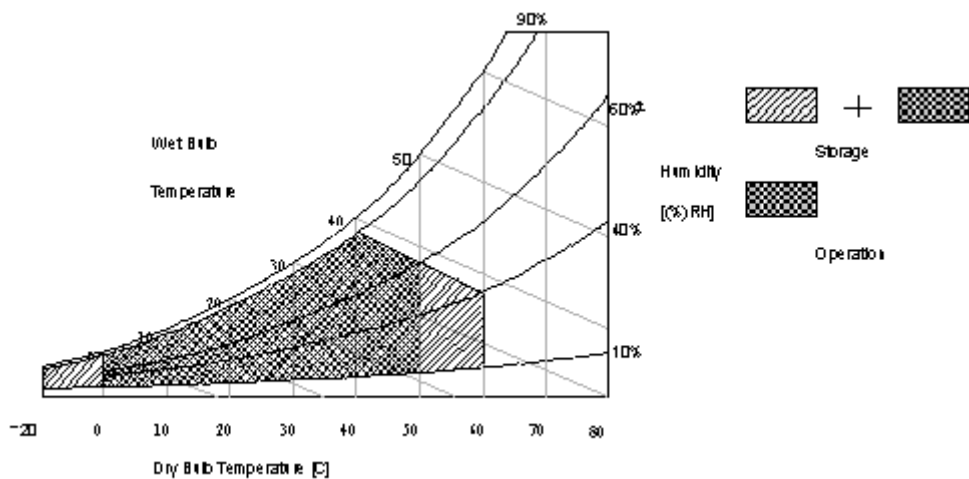

Title : CLAA315WA01 Technical Specification

3. ELECTRICAL CHARACTERISTICS

3.1 TFT-LCD MODULE

Ta=25°C

Item	Symbol	Min.	Typ.	Max.	Unit	Note
LCD Power Supply Voltage	VCC	10.8	12.0	13.2	V	*1)
Ripple Voltage	V _{ripd}	--	--	100	mVp-p	VCC=+12.0V
Rush current	I _{rush}	--	--	4	A	*2)
LCD Power Supply Current	White	--	450	--	mA	*3)
	Black	--	290			
	RGB stripe	--	530			
LCD power consumption	P _c	--	7.2	8.7	W	
High input voltage of LVDS	V _{IN+}	--	--	100	mV	*4)
Low input voltage of LVDS	V _{IN-}	100	--	--	mV	
Input common voltage of LVDS	V _{CM}	--	1.25	-	V	
Input terminal resistor of LVDS	R _T	--	100	--	ohm	

[Note 1] The module should be always operated within above ranges.

VCC-dip state :

1)When $9V \leq VCC < 10.8 V$, $t_d \leq 10$ ms.

$VCC > 10.8V$, VCC-dip condition should also follow the VCC-turn-off condition.

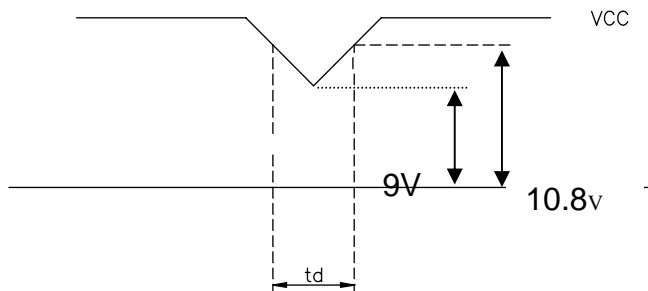

2) Measure conditions :

Title : CLAA315WA01 Technical Specification

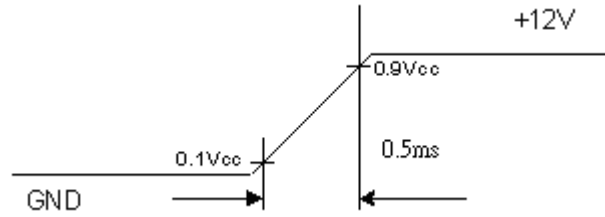

Vcc rising time is 0.5 ms

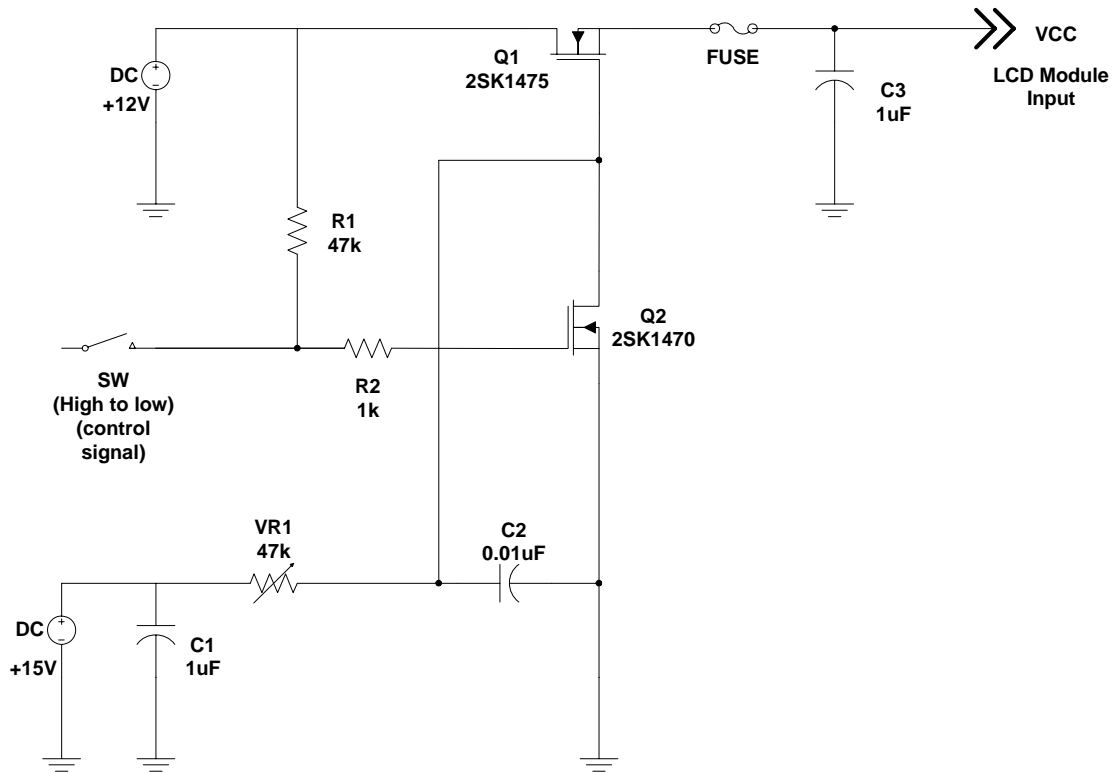

3) The specified power supply current is under condition at V_{cc}=12V, T_a=25+/-2°C, f_r=60Hz, whereas a power dissipation check pattern below is displayed.

a. White pattern

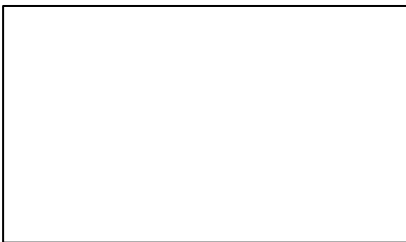

b. Black pattern

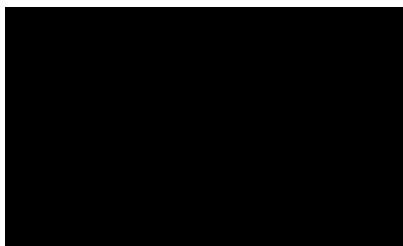

c. RGB Stripe pattern

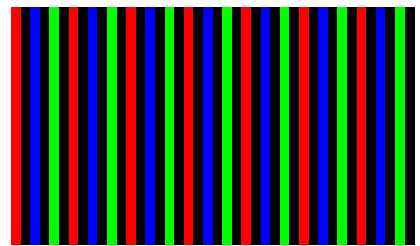

Title : CLAA315WA01 Technical Specification

4)LVDS signal definition :

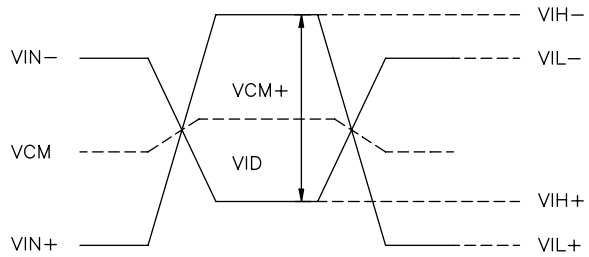
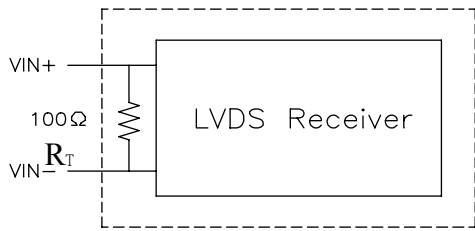

$$VID = VIN_+ - VIN_- , \Delta VCM = | VCM_+ - VCM_- | ,$$

$$\Delta VID = | VID_+ - VID_- | , VID_+ = | VIH_- - VIH_- | ,$$

$$VID_- = | VIL_+ - VIL_- | , VCM = (VIN_+ + VIN_-) / 2 ,$$

$$VCM_+ = (VIH_+ + VIH_-) / 2 , VCM_- = (VIL_+ + VIL_-) / 2$$

VIN+: Positive differential DATA & CLK input

VIN-: Negative differential DATA & CLK input

Title : CLAA315WA01 Technical Specification

POWER SEQUENCE

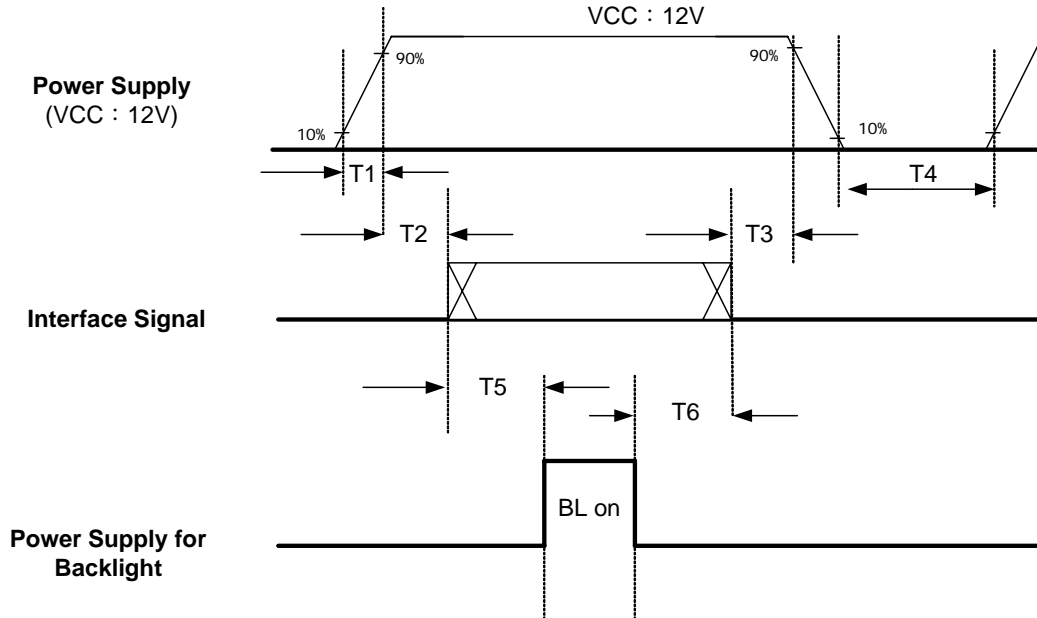

Parameter	Value			Unit
	Min	Typ	Max	
T1	0.5	---	30	ms
T2	0	---	50	ms
T3	0	---	50	ms
T4	2000	---		ms
T5	110	---		ms
T6	100	---		ms

[Note 1] Please avoid floating state of interface signal at invalid period.

[Note 2] When the interface signal is invalid, be sure to pull down the power supply of LCD to 0V.

[Note 3] Lamp power must be turn off after power supply of LCD which the interface signal is valid.

Title : CLAA315WA01 Technical Specification

3.3 Inverter and Lamp Specification for Back Lighting

Ta = 25°C, Turn on for 30 minutes

Item	Symbol	Min.	Typ.	Max.	Unit	Note	
Lamp Life Time	LT	50000	--	--	hr	*1)	
Input Voltage	VBL	21.6	24	26.4	V	*2)	
Input Current	IIN	--	2.41	2.66	A	*3)	
Internal PWM Dimming Control Voltage	PDIM	0	--	3.3	V	*4)	
Duty Ratio	D	20	--	100	%		
ON /OFF Control Voltage	ON	Von/off	2.0	--	5	V	
	OFF		0	--	0.8		
Power Consumption (Backlight)	BLW	--	58	64	W	*3)	

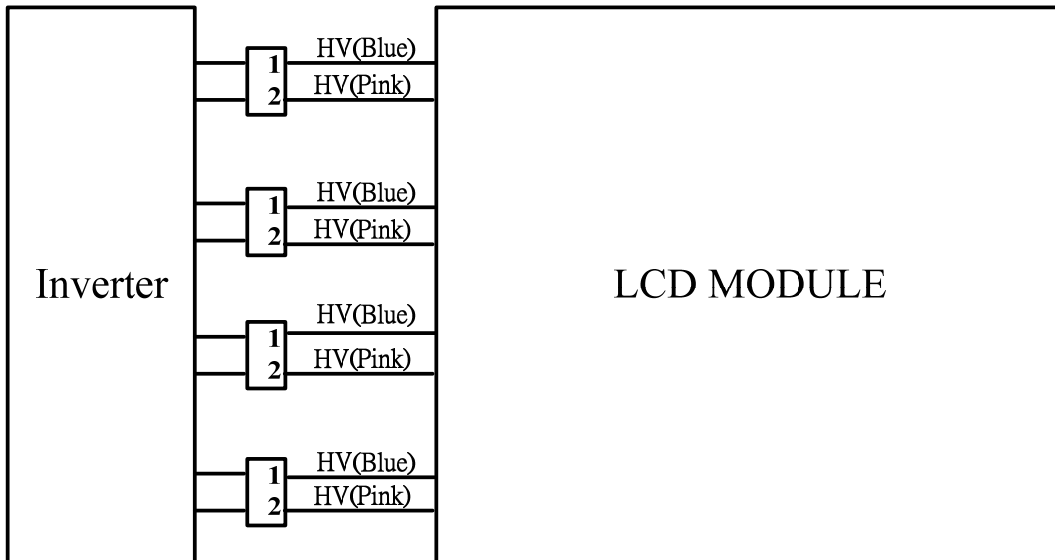

[Note 1] Definition of the lamp life time :

When lamp luminance reduce to 50% or lower than its initial value.

Title : CLAA315WA01 Technical Specification

[Note 2] Ripple voltage that occur at the instant of power-on can't exceed 27V.

[Note 3] 25°C; IPW=3.3V(Max.), after power on for 30 Minutes ; Max value of the power consumption and input current is measured at initial turn on of the backlight.

[Note 4] Internal PWM control with Analog input voltage.

Brightness is the darkest when IPW = 0V ;

Brightness is the brightest when IPW = 3.3V .

Title : CLAA315WA01 Technical Specification

4. INTERFACE PIN CONNECTION

4.1 TFT LCD MODULE

Connector Part No. : FI-E30S (JAE) or compatible

Pin NO	Symbol	Description	Note
1	NC	NC	*1)
2	NC	NC	*1)
3	NC	NC	*1)
4	GND	Ground	
5	RxIN0-	Data-	
6	RxIN0+	Data+	
7	GND	Ground	
8	RxIN1-	Data-	
9	RxIN1+	Data+	
10	GND	Ground	
11	RxIN2-	Data-	
12	RxIN2+	Data+	
13	GND	Ground	
14	RxCLKIN-	Clock-	
15	RxCLKIN+	Clock+	
16	GND	Ground	
17	RxIN3-	Data-	
18	RxIN3+	Data+	
19	GND	Ground	
20	NC	NC	*1)
21	DMS	LVDS Data Mapping Select	*1) *3)
22	Over Driving Select	Lookup table Selection(Ground / NC)	*1) *2)
23	GND	Ground	
24	GND	Ground	
25	GND	Ground	
26	VCC	Power supply: +12V	
27	VCC	Power supply: +12V	
28	VCC	Power supply: +12V	
29	VCC	Power supply: +12V	
30	VCC	Power supply: +12V	

[Note 1] NC : Must let it open

[Note 2] PAL/NTSC option

Over Driving Select (Pin22)	Frame Rate	Remark
GND	PAL (50Hz)	Lookup table is optimized for 50 Hz frame rate
NC	NTSC(60Hz)	Lookup table is optimized for 60 Hz frame rate

Title : CLAA315WA01 Technical Specification

[Note 3] LVDS OPTION :

DMS(Pin 21)	LVDS format	Remark
3.3V/NC	No-JEIDA	Refer to Page13
GND	JEIDA	Refer to Page13

4.2 LVDS Data Mapping

(1) Pin 21 : 3.3V/NC, Non-JEIDA mode

Non-JEIDA SPEC

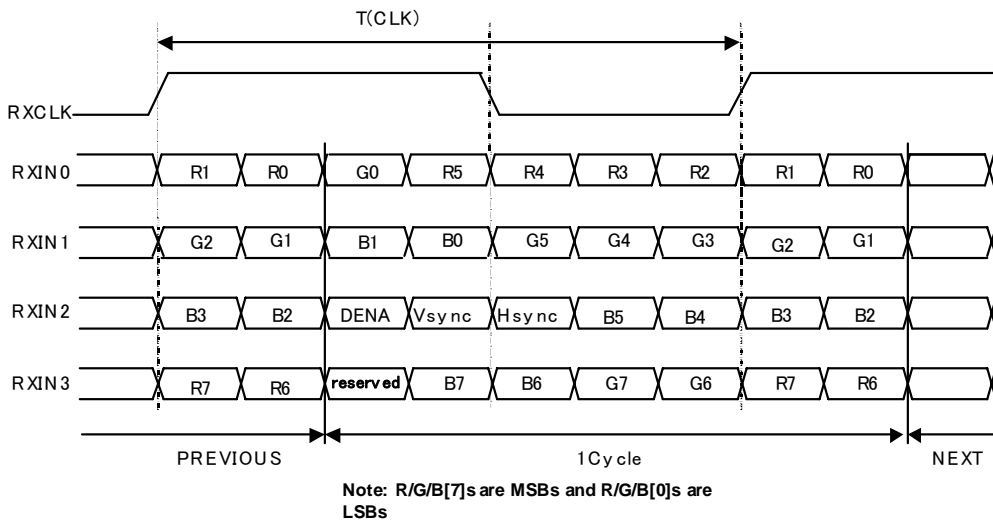

(2) Pin 21 : GND, JEIDA

JEIDA SPEC

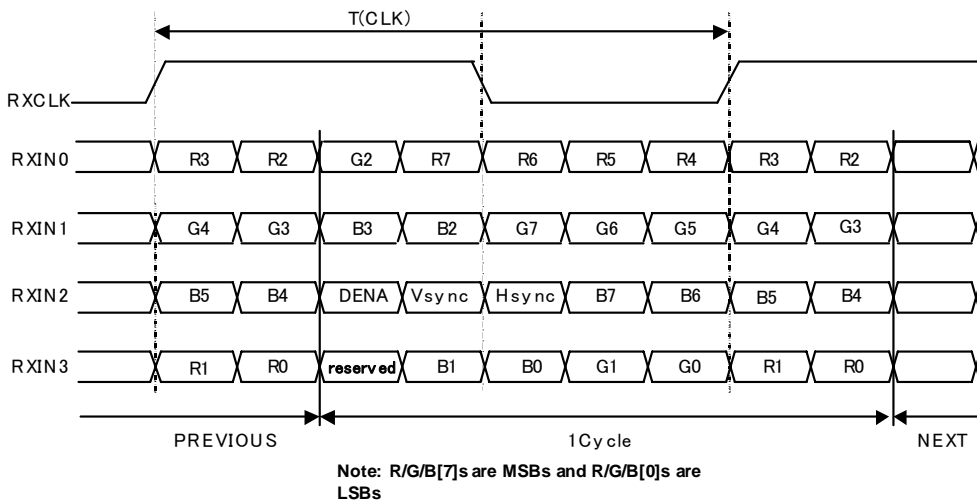

Title : CLAA315WA01 Technical Specification

4.3 LVDS Interface : LVDS Receiver : Tcon (LVDS Rx merged)

	LVDS pin	JEIDA-DATA	Non-JEIDA-DATA
TxOUT/RxIN0	TxIN/RxOUT0	R2	R0
	TxIN/RxOUT1	R3	R1
	TxIN/RxOUT2	R4	R2
	TxIN/RxOUT3	R5	R3
	TxIN/RxOUT4	R6	R4
	TxIN/RxOUT6	R7	R5
	TxIN/RxOUT7	G2	G0
TxOUT/RxIN1	TxIN/RxOUT8	G3	G1
	TxIN/RxOUT9	G4	G2
	TxIN/RxOUT12	G5	G3
	TxIN/RxOUT13	G6	G4
	TxIN/RxOUT14	G7	G5
	TxIN/RxOUT15	B2	B0
	TxIN/RxOUT18	B3	B1
TxOUT/RxIN2	TxIN/RxOUT19	B4	B2
	TxIN/RxOUT20	B5	B3
	TxIN/RxOUT21	B6	B4
	TxIN/RxOUT22	B7	B5
	TxIN/RxOUT24	Hsync	Hsync
	TxIN/RxOUT25	Vsync	Vsync
	TxIN/RxOUT26	DENA	DENA
TxOUT/RxIN3	TxIN/RxOUT27	R0	R6
	TxIN/RxOUT5	R1	R7
	TxIN/RxOUT10	G0	G6
	TxIN/RxOUT11	G1	G7
	TxIN/RxOUT16	B0	B6
	TxIN/RxOUT17	B1	B7
	TxIN/RxOUT23	Reserved	Reserved

Title : CLAA315WA01 Technical Specification

4.4 INVERTER

Inverter – Connector :

(1) Connector(Receptacle) : 20022WR-14AML (YEONHO) or compatible.

(2) Mating connector(Plug) : 20022HS-14L(YEONHO) or compatible.

Pin No.	Symbol	Description	Note
1	VBL	Supply Voltage 24V	
2	VBL	Supply Voltage 24V	
3	VBL	Supply Voltage 24V	
4	VBL	Supply Voltage 24V	
5	VBL	Supply Voltage 24V	
6	GND	Ground	
7	GND	Ground	
8	GND	Ground	
9	GND	Ground	
10	GND	Ground	
11	ERR	Normal :Low(GND) 0~0.5V Error: High(3~5V)	
12	ON/OFF	B/L On: NC /High(2.0~5.0V) B/L Off: GND (0~0.8V)	
13	IPWM	Internal PWM control	*1)
14	N.C	NC	

[Note 1] : Internal PWM is DC level signal using Saw Tooth Wave control.

Title : CLAA315WA01 Technical Specification

5. INTERFACE TIMING

5.1 TIMING SPECIFICATION

Signal	Item	Symbol	Min	Typ	Max	Unit	Note
Clock	Frequency	1/Tc	58.9	80	84	MHz	
Vertical Active Display Term	Frame Rate	Fr	47	60	63	Hz	
	Total	Tv	796	810	878	Th	Tv=Tvd+Tvb
	Display	Tvd	768	768	768	Th	
	Blank	Tvb	28	42	110	Th	
Horizontal Active Display Term	Total	Th	1575	1648	1936	Tc	Th=Thd+Thb
	Display	Thd	1366	1366	1366	Tc	
	Blank	Thb	209	282	570	Tc	

5.2 TIMING CHART

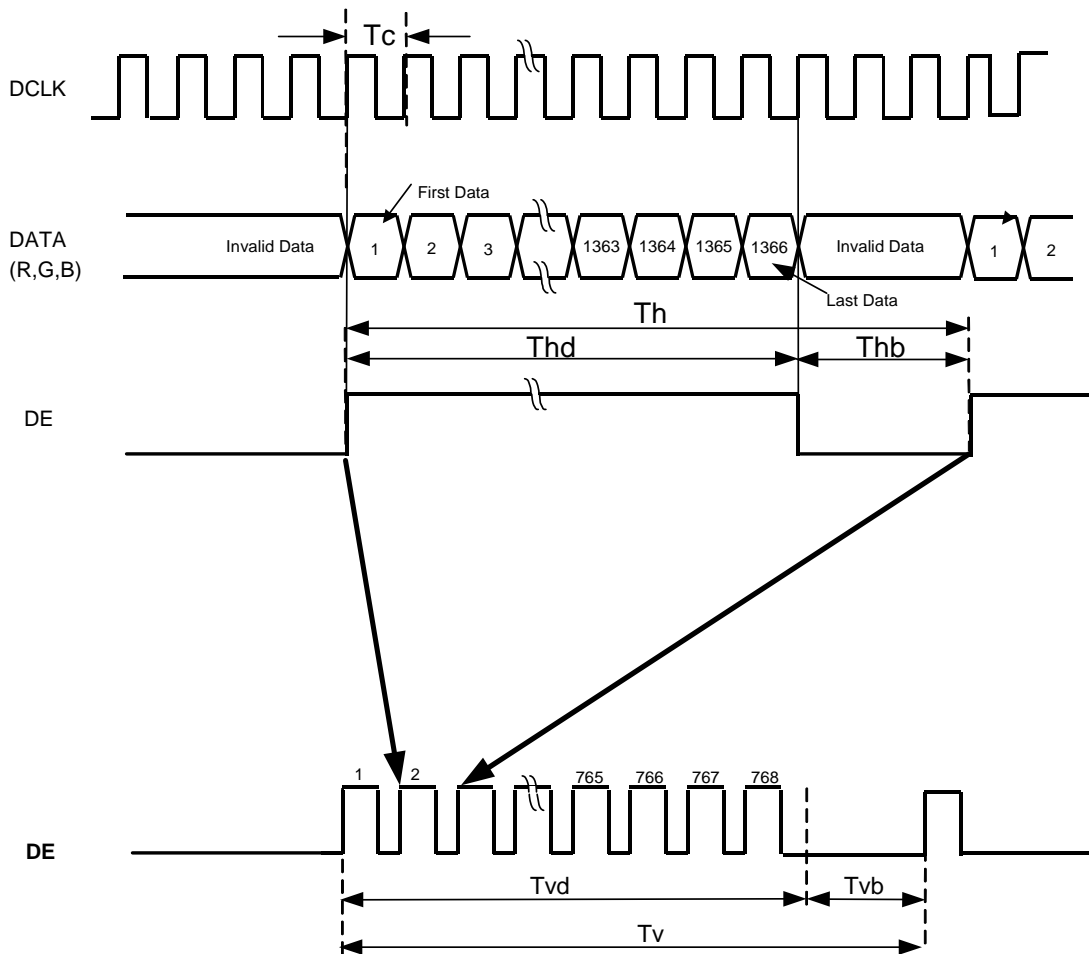

Title : CLAA315WA01 Technical Specification

5.3 COLOR DATA ASSIGNMENT

Data	INPUT Data	R Data								G Data								B Data							
		R7	R6	R5	R4	R3	R2	R1	R0	R7	R6	R5	R4	R3	R2	R1	R0	R7	R6	R5	R4	R3	R2	R1	R0
		MSB							LSB	MSB							LSB	MSB							LSB
BASIC COLOR	BLACK	0	0	0	0	0	0	0	0	0	0	0	0	0	0	0	0	0	0	0	0	0	0	0	0
	RED(255)	1	1	1	1	1	1	1	1	0	0	0	0	0	0	0	0	0	0	0	0	0	0	0	0
	GREEN(255)	0	0	0	0	0	0	0	0	1	1	1	1	1	1	1	1	0	0	0	0	0	0	0	0
	BLUE(255)	0	0	0	0	0	0	0	0	0	0	0	0	0	0	0	0	1	1	1	1	1	1	1	1
	CYAN	0	0	0	0	0	0	0	0	1	1	1	1	1	1	1	1	1	1	1	1	1	1	1	1
	MAGENTA	1	1	1	1	1	1	1	1	0	0	0	0	0	0	0	0	1	1	1	1	1	1	1	1
	YELLOW	1	1	1	1	1	1	1	1	1	1	1	1	1	1	1	1	0	0	0	0	0	0	0	0
	WHITE	1	1	1	1	1	1	1	1	1	1	1	1	1	1	1	1	1	1	1	1	1	1	1	1
RED	RED(0)	0	0	0	0	0	0	0	0	0	0	0	0	0	0	0	0	0	0	0	0	0	0	0	0
	RED(1)	0	0	0	0	0	0	0	1	0	0	0	0	0	0	0	0	0	0	0	0	0	0	0	0
	RED(2)	0	0	0	0	0	0	1	0	0	0	0	0	0	0	0	0	0	0	0	0	0	0	0	0
	RED(253)	1	1	1	1	1	1	0	1	0	0	0	0	0	0	0	0	0	0	0	0	0	0	0	0
	RED(254)	1	1	1	1	1	1	1	0	0	0	0	0	0	0	0	0	0	0	0	0	0	0	0	0
RED(255)	1	1	1	1	1	1	1	1	0	0	0	0	0	0	0	0	0	0	0	0	0	0	0	0	
GREEN	GREEN(0)	0	0	0	0	0	0	0	0	0	0	0	0	0	0	0	0	0	0	0	0	0	0	0	0
	GREEN(1)	0	0	0	0	0	0	0	0	0	0	0	0	0	0	1	0	0	0	0	0	0	0	0	0
	GREEN(2)	0	0	0	0	0	0	0	0	0	0	0	0	0	0	1	0	0	0	0	0	0	0	0	0
	GREEN(253)	0	0	0	0	0	0	0	0	1	1	1	1	1	1	0	1	0	0	0	0	0	0	0	0
	GREEN(254)	0	0	0	0	0	0	0	0	1	1	1	1	1	1	0	0	0	0	0	0	0	0	0	0
GREEN(255)	0	0	0	0	0	0	0	0	1	1	1	1	1	1	1	1	0	0	0	0	0	0	0	0	
BLUE	BLUE(0)	0	0	0	0	0	0	0	0	0	0	0	0	0	0	0	0	0	0	0	0	0	0	0	0
	BLUE(1)	0	0	0	0	0	0	0	0	0	0	0	0	0	0	0	0	0	0	0	0	0	0	0	1
	BLUE(2)	0	0	0	0	0	0	0	0	0	0	0	0	0	0	0	0	0	0	0	0	0	0	1	0
	BLUE(253)	0	0	0	0	0	0	0	0	0	0	0	0	0	0	0	1	1	1	1	1	1	1	0	1
	BLUE(254)	0	0	0	0	0	0	0	0	0	0	0	0	0	0	0	1	1	1	1	1	1	1	1	0
BLUE(255)	0	0	0	0	0	0	0	0	0	0	0	0	0	0	0	1	1	1	1	1	1	1	1	1	

[Note 1] Definition of gray scale

Color (n) : n indicates gray scale level , higher n means brighter level.

[Note 2] Data : 1-High level voltage , 0-Low level voltage ,

Title : CLAA315WA01 Technical Specification

6. BLOCK DIAGRAM

6.1 TFT LCD MODULE

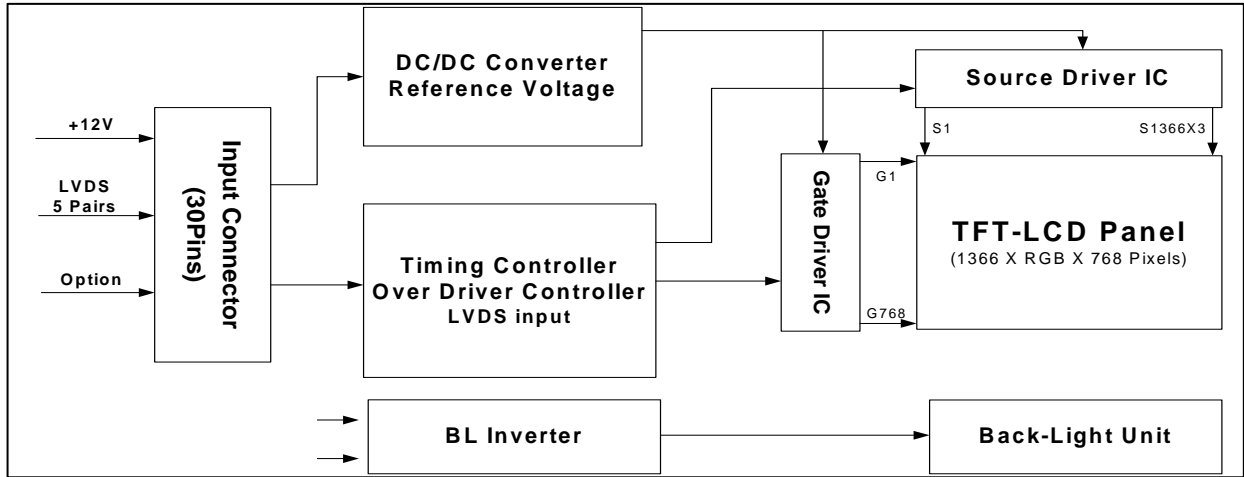

6.2 BACKLIGHT UNIT

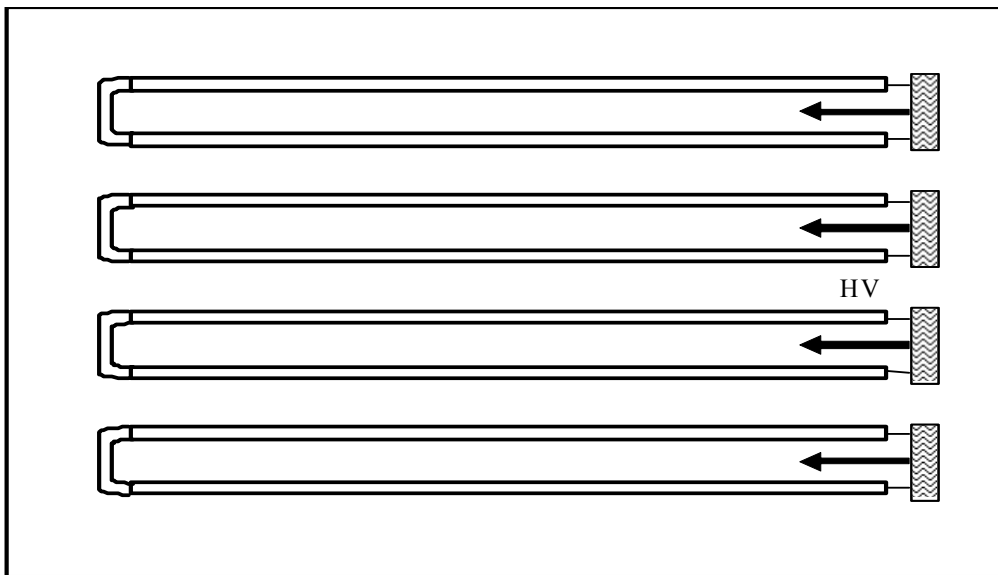

[Note 1] Lamp connector

HV : CP0404SL000(CVILUX)*4 or compatible

Mating connector : CP042CP1ML0-LF (CVILUX)*4 or compatible

Title : CLAA315WA01 Technical Specification

7. MECHANICAL SPECIFICATION

7.1 FRONT SIDE

(Including Inverter, if the dimension is not clear, please refer to the table.) [Unit: mm]

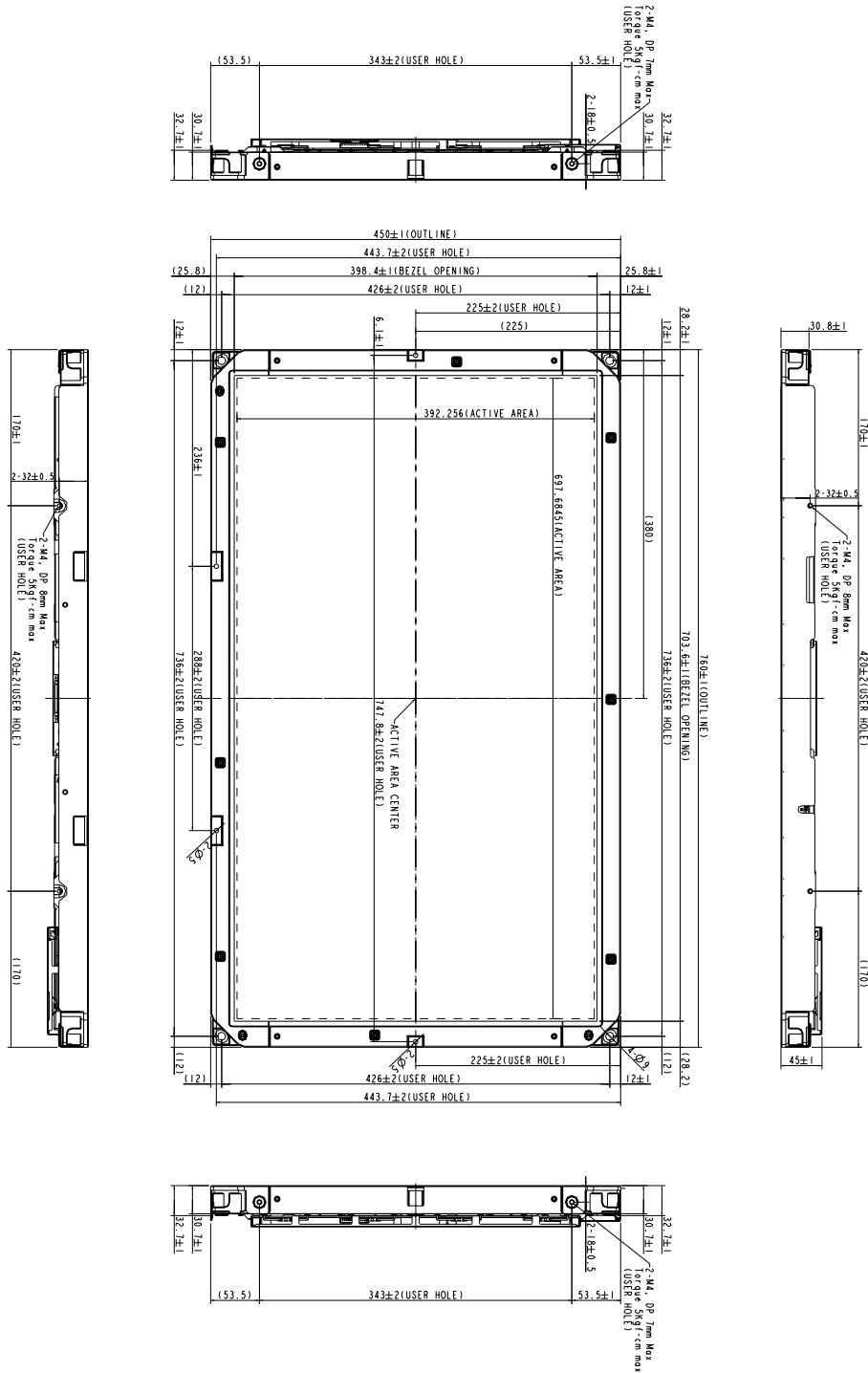

Title : CLAA315WA01 Technical Specification

7.2 REAR SIDE

(Including Inverter, if the dimension is not clear, please refer to the table.) [Unit: mm]

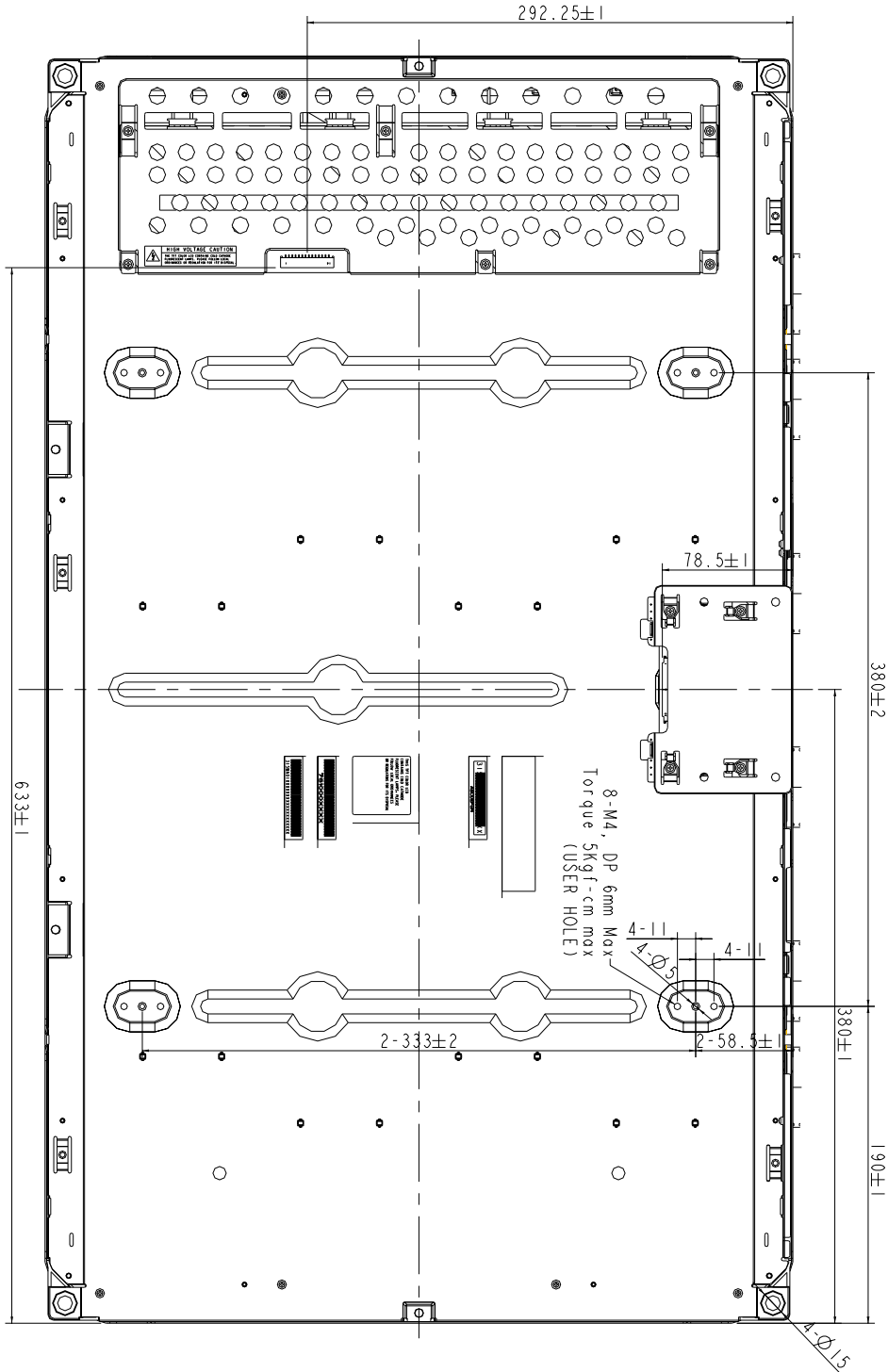

Title : CLAA315WA01 Technical Specification**8. OPTICAL CHARACTERISTICS**

Ta = 25°C, VCC=12V

Item	Symbol	Condition	Min.	Typ.	Max.	Unit	Note	
Contrast (CEN)	CR	$\theta = \psi = 0^\circ$ Point-5	2500	3000	--	--	*1)*2)*3)	
Luminance	Central luminance	$\theta = \psi = 0^\circ$	350	450	--	cd/m ²	*9)	
	9P Luminance (AVG)	$\theta = \psi = 0^\circ$	--	400	--	cd/m ²	*2)*3)	
	Uniformity	ΔLw	$\theta = \psi = 0^\circ$	75	--	--	%	*2)*3)
Response Time (White – Black)	tr	$\theta = \psi = 0^\circ$	--	10	17	ms	*3)*4)	
	tf	$\theta = \psi = 0^\circ$	--	6	10	ms	*3)*4)	
Response Time (Gray to gray)	trg, tfg	$\theta = \psi = 0^\circ$	--	6	--	ms	*5)	
View angle	Horizontal	ψ	$CR \geq 20$ Point-5	-80~80	-88~88	--	degree	*2)*3)
	Vertical	θ		-80~80	-88~88	--	degree	*2)*3)
Image sticking	tis	4 h	--	--	5	min	*6)	
Crosstalk Ratio	CMR	$\theta = \psi = 0^\circ$	--	--	4	%	*3)*7)	
Color Chromaticity	Red	Rx Ry	$\theta = \psi = 0^\circ$ Point-5	0.620 0.295	0.650 0.325	0.680 0.355	---	*2)*3)
	Green	Gx Gy		0.260 0.580	0.290 0.610	0.320 0.640		
	Blue	Bx By		0.115 0.025	0.145 0.055	0.175 0.085		
	White	Wx Wy		0.250 0.260	0.280 0.290	0.310 0.320		
Color Temperature	Tc	--	--	10000	--	K	*3)	
Color Gamut	CG	--	--	76	--	%	*8)	

[Note] Color Temperature Coordinate

These items are measured using : BM-5A (TOPCON)

[Under the dark room condition (no ambient light)]

Definition of these measurement items is as follows :

*1) Definition of Contrast Ratio :

Title : CLAA315WA01 Technical Specification

CR=ON (White) Luminance/OFF (Black) Luminance

*2) Definition of Luminance and Luminance uniformity and Contrast :

Luminance and Contrast : To measure at the center position “5” on the screen (NO.5), see Fig.8-1 below.

Luminance uniformity : Lw (MAX) and Lw(MIN) are the maximum and minimum luminance value measure at the position “1~9” on the screen (NO.1~9), see Fig.8-1 and below show equation :

$$\Delta L_w = L_w(\text{MIN}) / L_w(\text{MAX}) \times 100\%$$

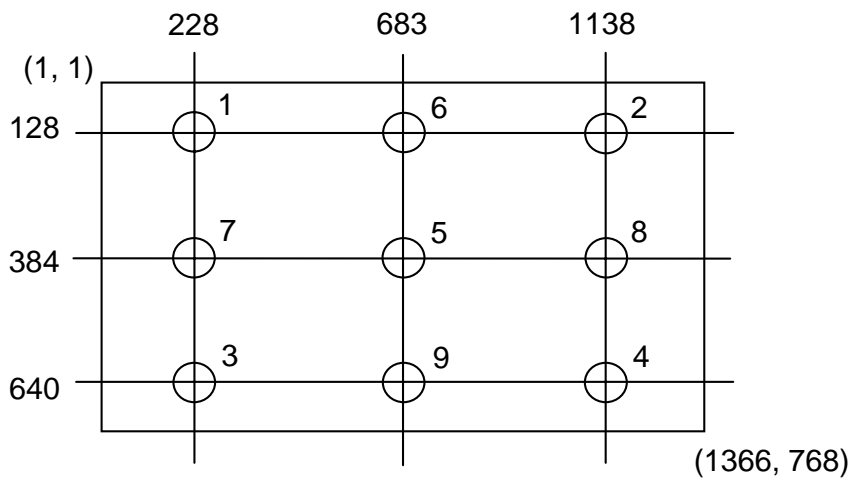

Figure 8-1. Measurement positions

*3) Definition of Viewing Angle (θ , ψ) :

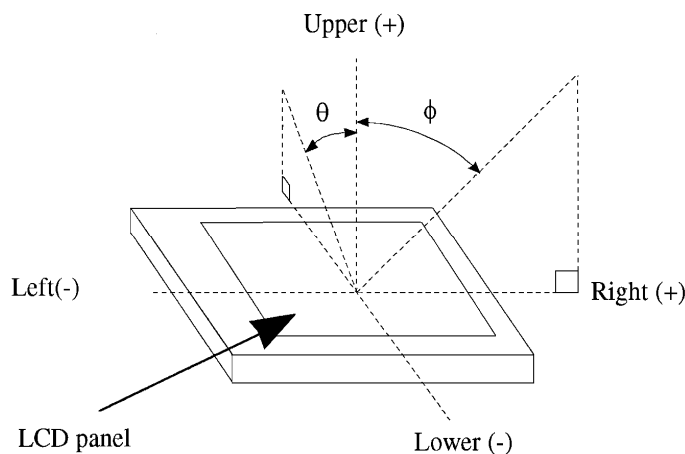

Figure 8-2. Definition of Viewing Angle

*4) Definition of Response Time (White – Black)

Title : CLAA315WA01 Technical Specification

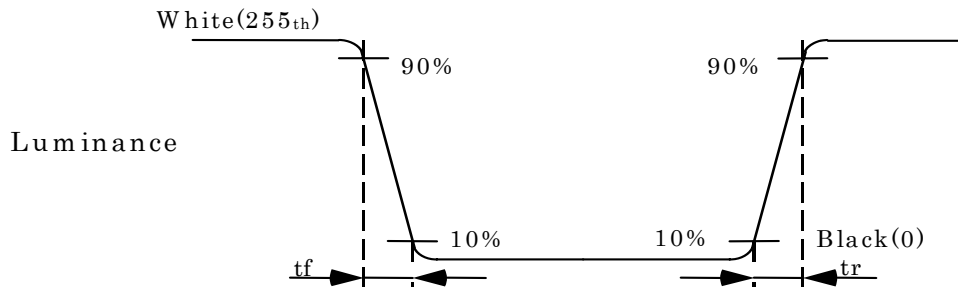

Figure 8-3. Definition of Response Time (White – Black)

*5) Definition of Response Time (Gray to Gray average)

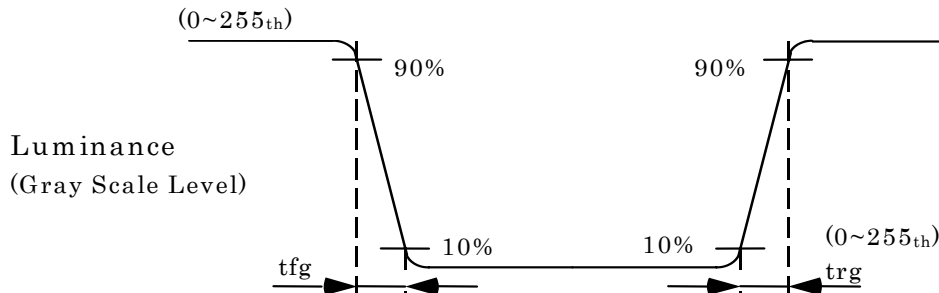

Figure 8-4. Definition of Response Time (Gray Scale Level)

The driving signal time means the signal of gray level 0、31、63、95、127、159、191、223、255.

Gray to gray average means the average switching time of gray level 0、31、63、95、127、159、191、223、255 to each other.

The LCD module should be stabilized at given temperature for 0.5 hour to avoid abrupt temperature change during measuring. In order to stabilize the luminance , the measurement should be executed after lighting Backlight for 0.5 hour in a windless room.

*6) Image sticking test method:

Continuously display the test pattern shown in the figure below for specified time. To change the module frame to gray pattern (gray 128 pattern) , and it's displaying grade still under specification.

Title : CLAA315WA01 Technical Specification

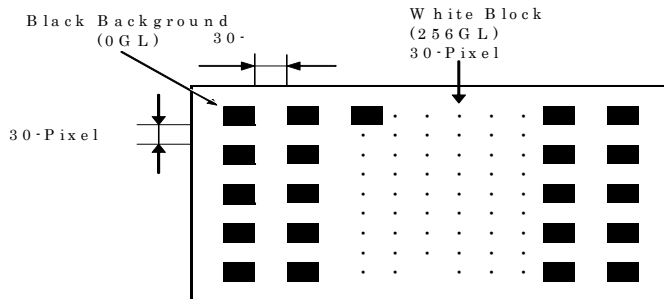
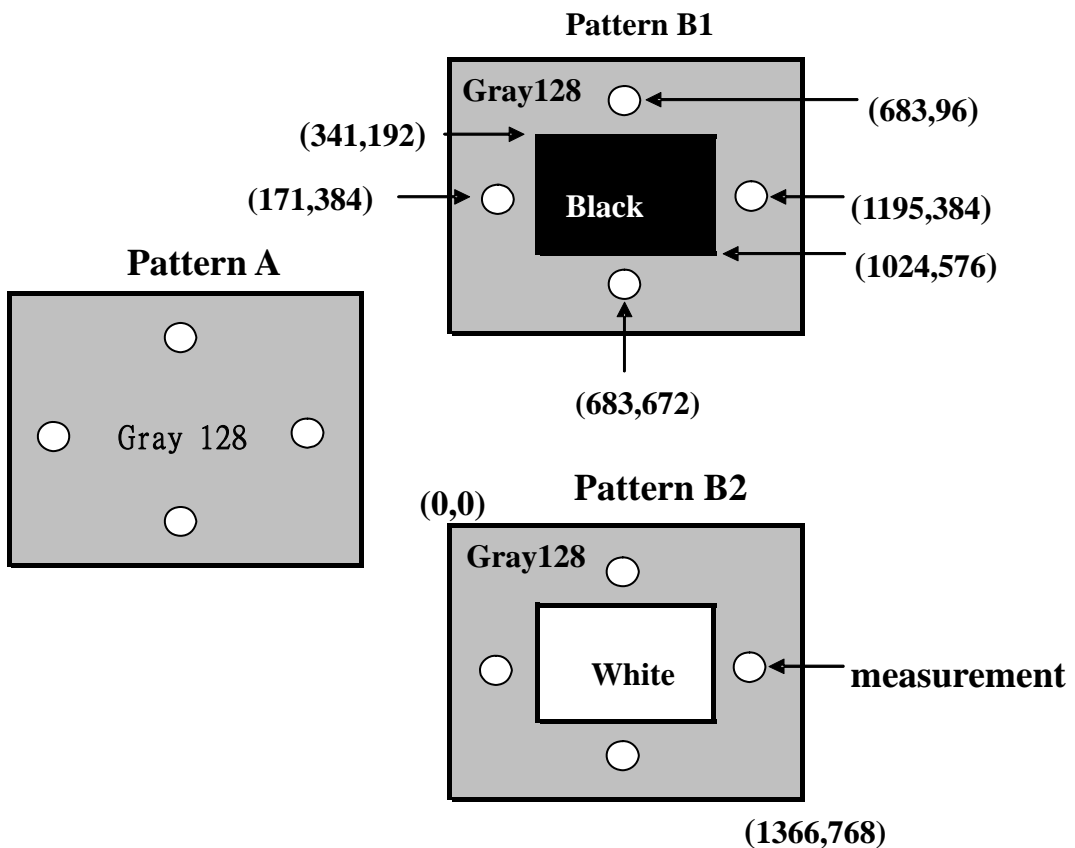

Figure 8-5. The pattern of Image sticking test

*7) Definition of Cross Talk Ratio= $\text{MAX} \left(\left(\frac{LB1-LA}{LA} \right) \times 100\% , \left(\frac{LB2 - LA}{LA} \right) \times 100\% \right)$

LA : Pattern A (Half-Tone pattern) Measure point Luminance

LB1 , LB2 : Pattern B1 、 Pattern B2 Measure point Luminance



Title : CLAA315WA01 Technical Specification

Figure 8-6. The pattern of crosstalk test

*8) Definition of Color Gamut:

To measure RGB three sub-pixels color gamut coordinate at CIE coordinate chart from the center of module , to form a triangle area = A_{RGB} .

RGB three sub-pixels of NTSC at CIE coordinate chart to form a triangle area = N_{RGB} .

$$CG = \frac{A_{RGB}}{N_{RGB}} \times 100 \%$$

*9) Definition of Central luminance:

After lighting on the panel 0.5hour, you can proceed the Central luminance testing.

Title : CLAA315WA01 Technical Specification

9.RELIABILITY TEST CONDITIONS

(1)Temperature and Humidity

TEST ITEMS	CONDITIONS
High Temperature Operation	50°C ; 240hrs
High Temperature Storage	60°C ; 240hrs
High Temperature High Humidity Operation	50°C ; 90% RH ; 240 hrs (No condensation)
Low Temperature Operation	0°C ; 240 hrs
Low Temperature Storage	-20°C ; 240 hrs
Thermal Shock	Between -20°C (1hr) and 60°C (1hr) ; 50 Cycles

(2)Shock & Vibration

ITEMS	CONDITIONS
Shock (Non-Operation)	Shock level : 980m/s ² (100G) Waveform : half sinusoidal wave, 2ms Number of shocks : one shock input in each direction of three mutually perpendicular axes for a total of six shock inputs.
Vibration (Non-Operation)	Vibration level : 14.7m/s ² (1.5G) zero to peak Waveform : sinusoidal Frequency range : 10 to 300 Hz Frequency sweep rate : 0.5 octave/min Duration : each x , y , z axis : 30 min , total 90 mins

(3)ESD test

Test Item	Test statements
Connector	200 pF , 0 Ω , ±250 V By using contact-mode to discharge each pin one time and then check the module frame.
Module	150pF , 330Ω , ±15KV 1. Under test conditions, by using air-mode to discharge each test point 25 times continuously and then check the module frame. 2. Under test conditions, by using contact-mode to discharge each test point of panel frame 25 times continuously and then check the module frame.

(4)Judgment standard

The judgment of the above test should be made as follow:

Pass: Normal display image with no obvious non-uniformity and no line defect.

Partial transformation of the module parts should be ignored.

Fail: No display image, obvious non-uniformity, or line defects.