



Chunghwa Picture Tubes, Ltd.

Technical Specification

To : Normal 版

Date : 2006.10.03

CPT TFT-LCD

CLAA320WB02 Y

ACCEPTED BY :

APPROVED BY	CHECKED BY	PREPARED BY
		TFT-LCD Product Planning Management General Division

Product Planning Management General Division

CHUNGHWA PICTURE TUBES, LTD.

1127 Hopin Rd., Padeh, Taoyuan, Taiwan 334, R.O.C.

TEL: +886-3-3675151 FAX: +886-3-377-3054

Doc.No:	CLAA320WB02-Tentative-Ver5.0-2006/10/03	Issue Date:	2006/10/03
---------	---	-------------	------------

T- 3650002- 000- A NEW

RECORD OF REVISIONS

Revision No.	Date	Page	Description
Ver 1.0	2006/02/06	--	The first edition issued.
Ver 2.0	2006/02/20	--	TBD→Update
Ver 3.0	2006/5/26	--	Format reorganized
Ver 4.0	2006/7/18	--	Color Coordinate finalized.
Ver 5.0	2006/10/03	23-24	Add packaging specifications and method

CONTENTS

No	Item	Page
1	OVERVIEW	3
2	ABSOLUTE MAXIMUM RATINGS	4
3	TFT-LCD MODULE	5
4	INTERFACE PIN CONNECTION	9
5	INTERFACE TIMING	13
6	BLOCK DIAGRAM	16
7	MECHANICAL SPECIFICATION	17
8	OPTICAL CHARACTERISTICS	19
9	RELIABILITY	22
10	PACKAGING	23
11	HANDLING PRECAUTIONS FOR TFT-LCD MODULE	25

1. OVERVIEW

CLAA320WB02 is 32" color (80.04cm) TFT-LCD (Thin Film Transistor Liquid Crystal Display) module composed of LCD panel, LVDS driver ICs, control circuit, backlight, and inverter. By applying 8 bit digital data, 1366*768, 16.7 million-color images are displayed on the 32" diagonal screen. General specification are summarized in the following table:

1.1 GENERAL INFORMATION

ITEM		SPECIFICATION	UNIT	
Display Area		697.68 (H) × 392.25 (V) (31.51 inch diagonal)	mm	
Number of Pixels		1366 (H) × 768 (V)	16:9	
Pixel Pitch		0.51075 (H) × 0.51075 (V)	mm	
Bezel Opening Area		703.6 x 398.3	mm	
Color Pixel Arrangement		RGB Vertical Strip		
Display Mode		Normally Black		
Number of Colors		16.7M (8bit)	color	
Wide View Technology		MVA		
Electrical Interface		LVDS		
Power Consumption		113 (Typ.)	W	
Module Outline Dimension	Horizontal(H)	760 (Typ.)	mm	
	Vertical(V)	450 (Typ.)	mm	
	Depth	without inverter	38.6 (Typ.)	mm
		with inverter	45 (Typ.)	mm
Module Weight		7800 (Typ.)	g	
Backlight Unit		CCFL, 16 tables		
Surface Treatment		Hard coating, Surface-hardness: 3H		

The LCD products listed on this document are not suitable for use of aerospace equipment, submarine cables, and nuclear reactor control system and life support systems. If customers intend to use these LCD products for above application or not listed in "Standard" as follows, please contact our sales people in advance.

Standard: Computer, Office equipment, Communication equipment, Test and Measurement equipment, Machine tool, Industrial robot, Audio and Visual equipment, Other consumer products.

2. ABSOLUTE MAXIMUM RATINGS

The following are maximum values which, if exceeded, may cause faulty operation or damage to the module.

ITEM	SYMBOL	MIN.	MAX.	UNIT	REMARK
Power Supply Voltage For LCD	VCC	- 0.3	15.0	V	
Input voltage of inverter	VBL	- 0.3	27.0	V	
Inverter dimming	VDIM	- 0.3	3.5	Vdc	
Backlight on control voltage	V _B LON	- 0.3	5.5	Vdc	
ESD for Connector	VESD	-250	250	V	
ESD for Module	VESD	-15	15	KV	
Operation Ambient Temperature	T _{op}	0	50	°C	*1) *2) *3) *4)
Storage Temperature	T _{stg}	-20	60	°C	*1) *2) *3) *4)

[Note]

- *1) The relative temperature and humidity range are as below sketch. (90%RHMax / Ta ≤ 40°C)
- *2) The maximum wet bulb temperature ≤ 39°C (Ta > 40°C) and without dewing.
- *3) If you use the product in a environment which over the definition of temperature and humidity too long, and it will effect the result of visible inspection.
- *4) While the product operates in normal temperature range, the center surface of panel should be under 60°C.
- *5) Input voltage of the connector side in Inverter.
 Humidity: Humidity ≤ 85%RH without condensation.
 Relative Humidity ≤ 90% (Ta ≤ 40°C)
 Wet Bulb Temperature ≤ 39°C (Ta ≥ 40°C)

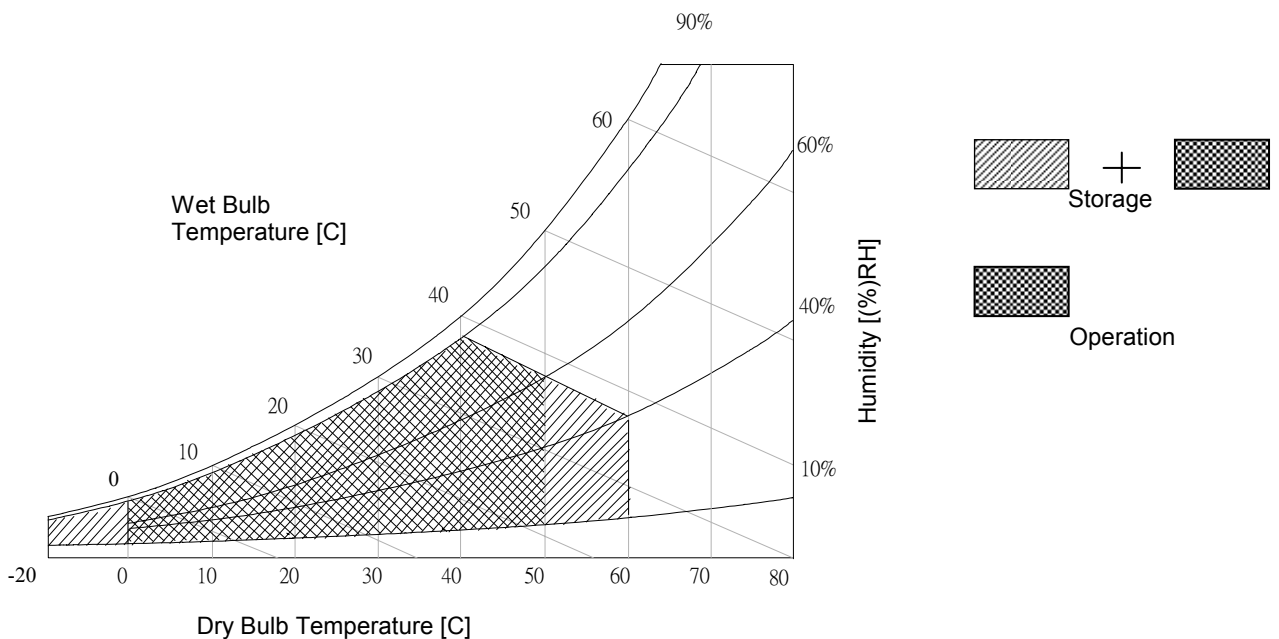

3. ELECTRICAL CHARACTERISTICS

3.1 TFT-LCD MODULE

Ta=25°C

Item	Symbol	Min.	Typ.	Max.	Unit	Note
LCD Power Supply Voltage	VCC	11.4	12.0	12.6	V	*1)
Ripple Voltage	Vrpd	--	--	100	mVp-p	VCC=+12.0V
Rush Current	Irush	--	--	4	A	*2)
LCD Power Supply Current	White	ICC	400	--	mA	*3)
	Black		300			
	RGB stripe		350			
LCD Power Consumption	Pc	--	5	8	W	
High Input Voltage of LVDS	V _{IN+}	--	--	100	mV	*4)
Low Input Voltage of LVDS	V _{IN-}	100	--	--	mV	
Input Common Voltage of LVDS	VCM	--	1.25	-	V	
Input Terminal Resist of LVDS	R _T	--	100	--	ohm	

[Note] The module should be always operated within above ranges.

*1) VCC-dip State:

- When $9V \leq VCC < 11.4V$, $t_d \leq 10ms$.
- $VCC > 11.4V$, VCC-dip condition should also follow the VCC-turn-off condition.

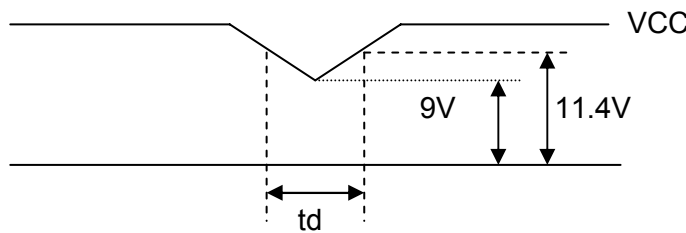

*2) Measure conditions:

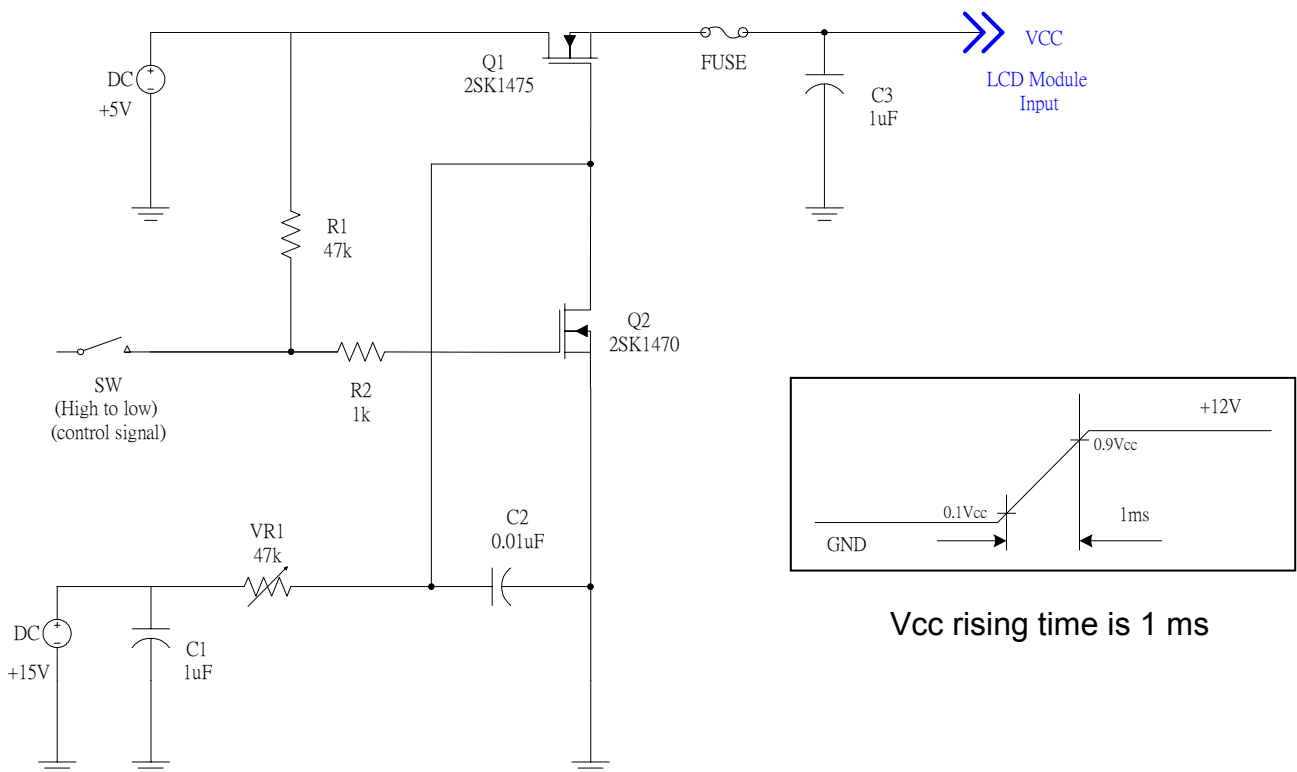

*3) The specified power supply current is under condition at $V_{cc}=12V$, $T_a=25\pm 2^\circ C$, $f_v=60Hz$, whereas a power dissipation check pattern below is displayed.

a. White pattern



b. Black pattern

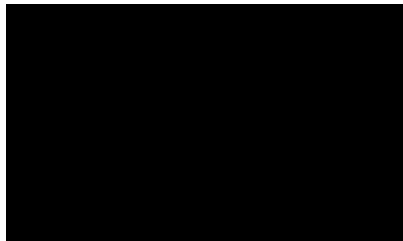

c. RGB Stripe pattern

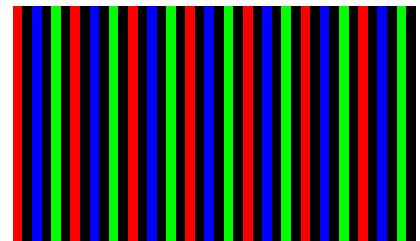

*4) LVDS Signal Definition:

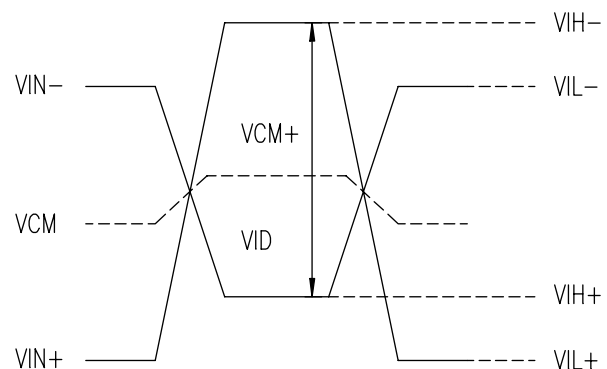
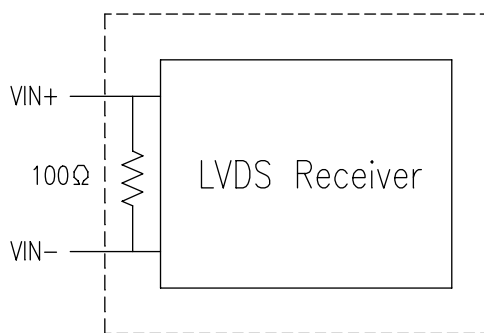

$$VID = VIN_+ - VIN_-$$

$$\Delta VCM = |VCM_+ - VCM_-|$$

$$\Delta VID = |VID_+ - VID_-|$$

$$VID_+ = |VIH_+ - VIH_-|$$

$$VID_- = |VIL_+ - VIL_-|$$

$$VCM = (VIN_+ + VIN_-) / 2$$

$$VCM_+ = (VIH_+ + VIH_-) / 2$$

$$VCM_- = (VIL_+ + VIL_-) / 2$$

VIN+: Positive Polarity differential DATA & CLK input

VIN-: Negative Polarity differential DATA & CLK input

Power and Signal Sequence:

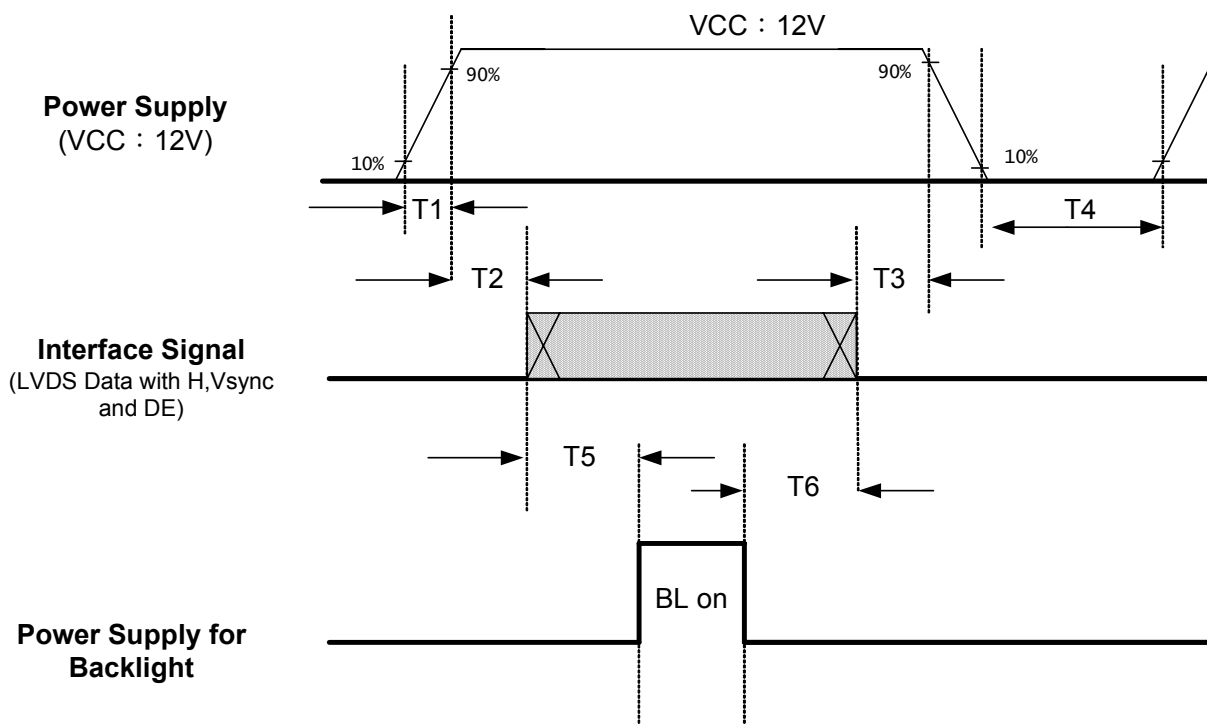

Power Sequence Table

Parameter	Value			Unit
	Min	Typ	Max	
T1	1	---	30	ms
T2	0	---	50	ms
T3	1	---	50	ms
T4	2000	---		ms
T5	110	---		ms
T6	100	---		ms

Notes:

- Please avoid floating state of interface signal at invalid period.
- When the interface signal is invalid, be sure to pull down the power supply for LCD to 0V.
- Lamp power must be turn off after power supply for LCD interface signal valid.

3.2 BACKLIGHT

Ta = 25°C, VCC=12V, Turn on for 30 minutes

ITEM	SYMBOL	MIN	TYP	MAX	UNIT	REMARK	
Lamp Life Time	LT	50000	--	--	hr	*1)	
Input Voltage of Inverter	VBL	21.6	24	26.4	V	*2)	
Input Current of Inverter	IIN	--	4.5	5.5	A	*3)	
Internal Dimming Control Voltage	PDIM	0	--	3.3	V	*4)	
External PWM Frequency	FDIM	100	--	350	Hz		
External PWM Dimming Control Voltage	PDIM	2.0	--	3.3	V	High *5)	
	PDIM	0	--	0.8	V	Low *5)	
PWM Select Voltage	Vsel	2.0	--	3.3	V	High *5)	
	Vsel	0	--	0.8	V	Low*5)	
Inverter Duty Ratio	D	20	--	100	%		
Backlight on /off Control Voltage	ON	VBLON	2.0	--	5.0	V	
	OFF		0	--	0.8		
Power Consumption (Backlight)	BLW	--	108	132	W	*3)	

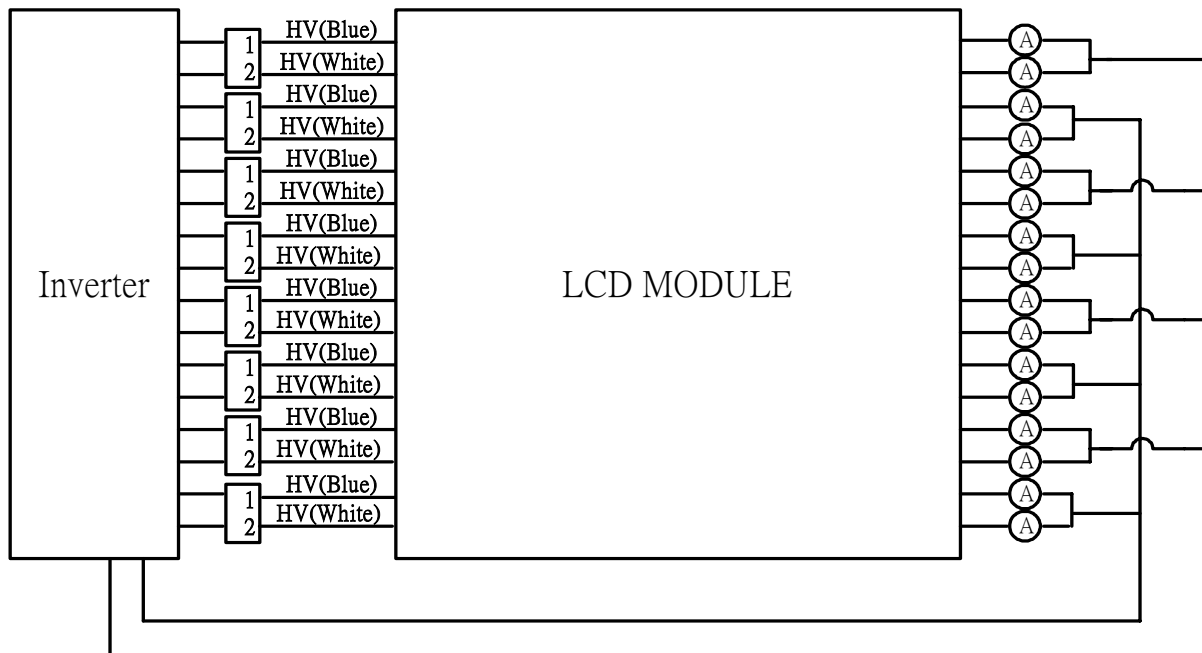

[Note]

- *1) Definition of the lamp life time:
When lamp luminance reduce to 50% or lower than its initial value.
- *2) Ripple voltage that occur at the instant of power-on can't exceed 27V.
- *3) Max value of the power consumption and input current is measured at initial turn on of the backlight.
- *4) Internal PWM control with Analog input voltage.
Brightness is the darkest when VDIM = 0V;
Brightness is the brightest when VDIM = 3.3V.
- *5) Duty Signal Input with 3.3V TTL specification.

4. INTERFACE PIN CONNECTION

4.1 Connector Part No.: 20389-030E(I-PEX), FI-X30SSL-HF(JAE), or compatible

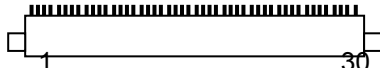

Pin NO	Symbol	Description	Note
1	VCC	+12V, DC, Regulated	
2	VCC	+12V, DC, Regulated	
3	VCC	+12V, DC, Regulated	
4	VCC	+12V, DC, Regulated	
5	GND	Ground	
6	OD SEL	OverDrive Selection (GND/ NC)	(1)
7	GND	DE Mode	
8	GND	Ground	
9	DMS	LVDS Option	(2)
10	NC	No Connection	(3)
11	GND	Ground	
12	RxIN0-	Data-	
13	RxIN0+	Data+	
14	GND	Ground	
15	RxIN1-	Data-	
16	RxIN1+	Data+	
17	GND	Ground	
18	RxIN2-	Data-	
19	RxIN2+	Data+	
20	GND	Ground	
21	RxCLKIN-	Clock-	
22	RxCLKIN+	Clock+	
23	GND	Ground	
24	RxIN3-	Data-	
25	RxIN3+	Data+	
26	GND	Ground	
27	NC	No Connection	(3)
28	NC	No Connection	(3)
29	GND	Ground	
30	GND	Ground	

[Note]

*1) PAL/NTSC option

Frame Rate Select (Pin 6)	Frame Rate
GND	PAL (50Hz)
NC	NTSC (60Hz)

*2) LVDS Option (DMS):

DMS (Pin 9)	LVDS format
GND /Open	Non-JEIDA (Normal)
High (3.3V)	JEIDA

*3) Reserved for internal use.
Must be open.

4.2 LVDS DATA MAPPING

(1) Pin 9 : GND/NC, Non-JEIDA mode

Non-JEIDA SPEC

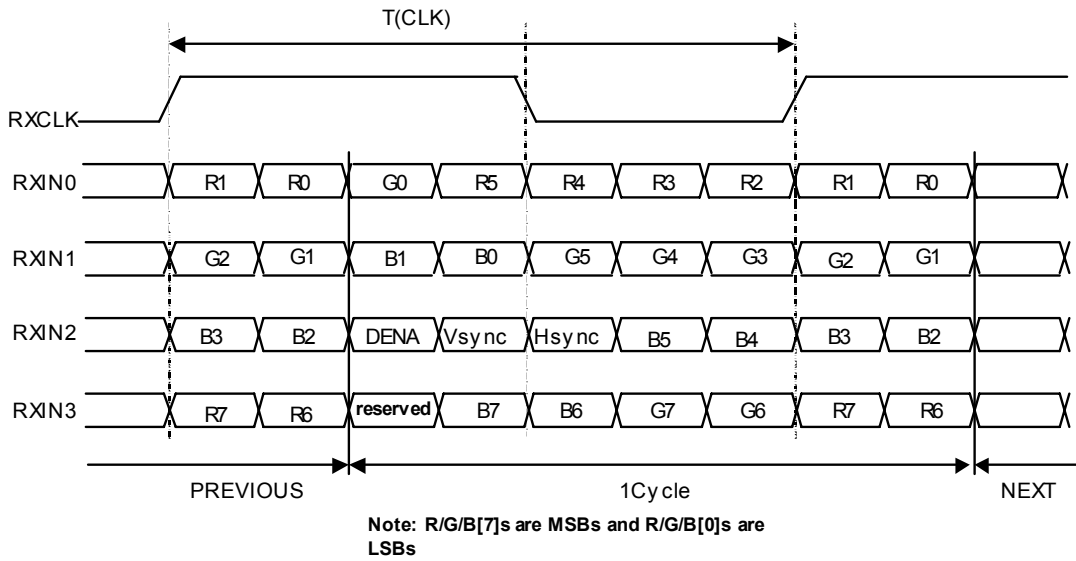

(2) Pin 9 : 3.3V, JEIDA mode

JEIDA SPEC

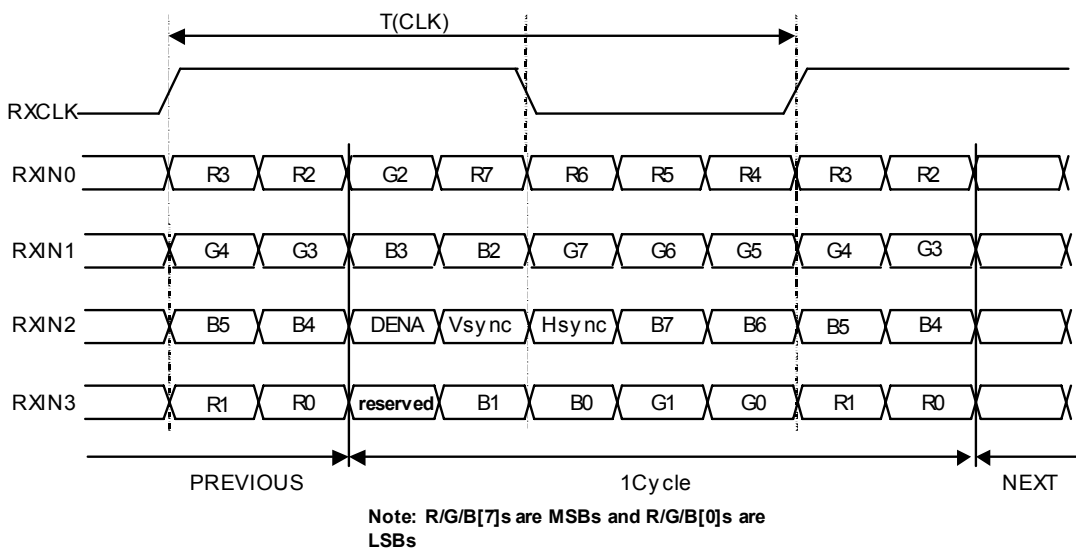

4.3 LVDS INTERFACE:**LVDS RECEIVER: Tcon (LVDS Rx merged)**

	LVDS pin	JEIDA-DATA	Non-JEIDA-DATA
TxOUT/RxIN0	TxIN/RxOUT0	R2	R0
	TxIN/RxOUT1	R3	R1
	TxIN/RxOUT2	R4	R2
	TxIN/RxOUT3	R5	R3
	TxIN/RxOUT4	R6	R4
	TxIN/RxOUT6	R7	R5
	TxIN/RxOUT7	G2	G0
TxOUT/RxIN1	TxIN/RxOUT8	G3	G1
	TxIN/RxOUT9	G4	G2
	TxIN/RxOUT12	G5	G3
	TxIN/RxOUT13	G6	G4
	TxIN/RxOUT14	G7	G5
	TxIN/RxOUT15	B2	B0
	TxIN/RxOUT18	B3	B1
TxOUT/RxIN2	TxIN/RxOUT19	B4	B2
	TxIN/RxOUT20	B5	B3
	TxIN/RxOUT21	B6	B4
	TxIN/RxOUT22	B7	B5
	TxIN/RxOUT24	Hsync	Hsync
	TxIN/RxOUT25	Vsync	Vsync
	TxIN/RxOUT26	DENA	DENA
TxOUT/RxIN3	TxIN/RxOUT27	R0	R6
	TxIN/RxOUT5	R1	R7
	TxIN/RxOUT10	G0	G6
	TxIN/RxOUT11	G1	G7
	TxIN/RxOUT16	B0	B6
	TxIN/RxOUT17	B1	B7
	TxIN/RxOUT23	Reserved	Reserved

4.4 INVERTER

Connector (Receptacle): S14B-PH-SM3-TB (JST) or compatible

Mating connector (Plug): PRH-14 (JST) or compatible

Pin No.	Symbol	Description	Note
1	VBL	Supply Voltage 24V	
2	VBL	Supply Voltage 24V	
3	VBL	Supply Voltage 24V	
4	VBL	Supply Voltage 24V	
5	VBL	Supply Voltage 24V	
6	GND	Ground	
7	GND	Ground	
8	GND	Ground	
9	GND	Ground	
10	GND	Ground	
11	NC	NC (Test pin or else)	
12	B/L ON/ OFF	B/L On: NC /High (2.0~5.0V) B/L Off: GND (0~0.8V)	
13	PDIM	External PWM or Internal PWM with Analog Input (Min.:0V; Max: 3.3V)	(1)
14	Vsel	GND: External PWM Dimming (Pin 13) NC /High: Internal PWM with Analog Input (Pin 13)	(2)

[Note]

- *1) PDIM is External PWM control or Analog control input; i.e. External PWM should be able to control width of Voltage Burst of inverter output for Lamp Driving. This input can have two types of input; ordinary default setting will be DC level signal using Saw Tooth Wave control for PWM duty control. The other setting is Duty Signal input with 3.3V TTL specification. These two methods should be decided by 14th Pin input setting.
- *2) 14th Pin is selection pin for PWM control method; if this pin is connected to GND, PDIM input of 13th Pin should have Logic Level Duty Signal for PWM control. If this is set to High or NC, 13th Pin should have DC level signal.

5. INTERFACE TIMING (DE only mode)

5.1 TIMING SPECIFICATION

ITEM		SYMBOL	MIN.	TYP.	MAX.	UNIT		
LCD Timing	DCLK	Freq.	f_{CLK}	62	80	84	MHz	
		Cycle	t_{CLK}	14.7	12.5	11.9	ns	
	DENA	Horizontal	Line Rate	f_H	37.1	48.6	56	kHz
			Horizontal Total Time	t_H	1575	1648	1936	t_{CLK}
			Horizontal Effective Time	t_{HA}	1366	1366	1366	t_{CLK}
			Horizontal Blank Time	t_{HB}	209	282	570	t_{CLK}
	DENA	Vertical	Frame Rate	Fr	47	60	63	PAL:47~53Hz NTSC:57~63Hz
			Vertical Total Time	t_V	790	810	888	t_H
			Vertical Effective Time	t_{VA}	768	768	768	t_H
			Vertical Blank Time	t_{VB}	22	42	120	t_H

[Note]

*1) The best result of over-driving is in frame rate =60Hz.

*2) PAL: 47~53Hz, NTSC: 57~63Hz.

5.2 TIMING CHART

a. Horizontal Timing

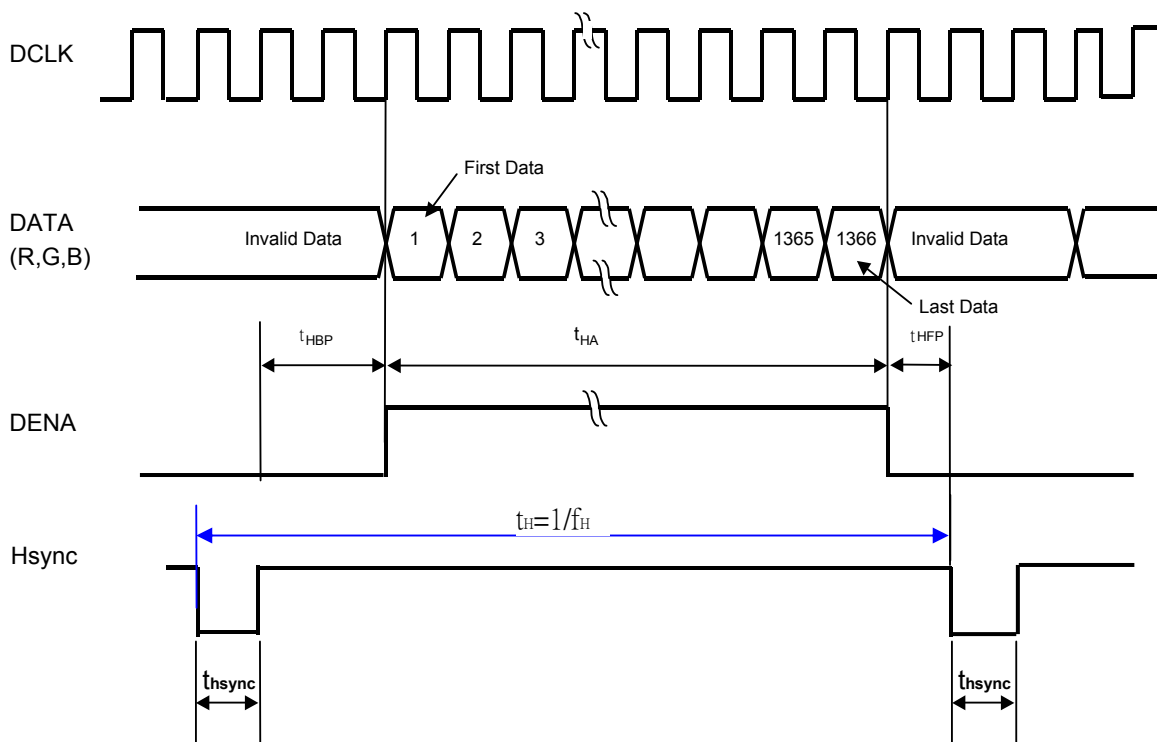

b. Vertical Timing Chart

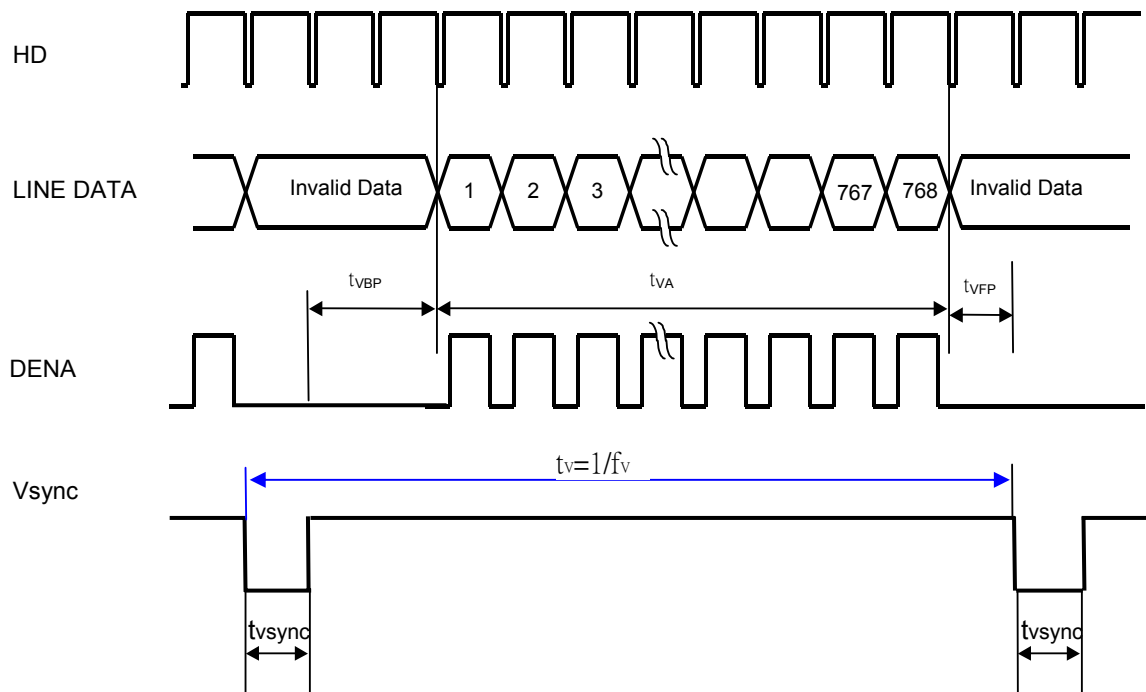

5.3 COLOR DATA ASSIGNMENT

COLOR	INPUT DATA	B DATA								G DATA								R DATA							
		B7	B6	B5	B4	B3	B2	B1	B0	G7	G6	G5	G4	G3	G2	G1	G0	R7	R6	R5	R4	R3	R2	R1	R0
		MSE							ISE	MSE							ISE	MSE							ISE
BASIC COLOR	BLACK	0	0	0	0	0	0	0	0	0	0	0	0	0	0	0	0	0	0	0	0	0	0	0	0
	RED(255)	1	1	1	1	1	1	1	1	0	0	0	0	0	0	0	0	0	0	0	0	0	0	0	0
	GREEN(255)	0	0	0	0	0	0	0	0	1	1	1	1	1	1	1	1	0	0	0	0	0	0	0	0
	BLUE(255)	0	0	0	0	0	0	0	0	0	0	0	0	0	0	0	0	1	1	1	1	1	1	1	1
	CYAN	0	0	0	0	0	0	0	0	1	1	1	1	1	1	1	1	1	1	1	1	1	1	1	1
	MAGENTA	1	1	1	1	1	1	1	1	0	0	0	0	0	0	0	0	1	1	1	1	1	1	1	1
	YELLOW	1	1	1	1	1	1	1	1	1	1	1	1	1	1	1	1	0	0	0	0	0	0	0	0
	WHITE	1	1	1	1	1	1	1	1	1	1	1	1	1	1	1	1	1	1	1	1	1	1	1	1
RED	RED(0)	0	0	0	0	0	0	0	0	0	0	0	0	0	0	0	0	0	0	0	0	0	0	0	0
	RED(1)	0	0	0	0	0	0	0	1	0	0	0	0	0	0	0	0	0	0	0	0	0	0	0	0
	RED(2)	0	0	0	0	0	0	1	0	0	0	0	0	0	0	0	0	0	0	0	0	0	0	0	0
	RED(253)	1	1	1	1	1	1	0	1	0	0	0	0	0	0	0	0	0	0	0	0	0	0	0	0
	RED(254)	1	1	1	1	1	1	1	0	0	0	0	0	0	0	0	0	0	0	0	0	0	0	0	0
	RED(255)	1	1	1	1	1	1	1	1	0	0	0	0	0	0	0	0	0	0	0	0	0	0	0	0
GREEN	GREEN(0)	0	0	0	0	0	0	0	0	0	0	0	0	0	0	0	0	0	0	0	0	0	0	0	0
	GREEN(1)	0	0	0	0	0	0	0	0	0	0	0	0	0	0	0	1	0	0	0	0	0	0	0	0
	GREEN(2)	0	0	0	0	0	0	0	0	0	0	0	0	0	0	1	0	0	0	0	0	0	0	0	0
	GREEN(253)	0	0	0	0	0	0	0	0	1	1	1	1	1	1	0	1	0	0	0	0	0	0	0	0
	GREEN(254)	0	0	0	0	0	0	0	0	1	1	1	1	1	1	1	0	0	0	0	0	0	0	0	0
	GREEN(255)	0	0	0	0	0	0	0	0	1	1	1	1	1	1	1	1	0	0	0	0	0	0	0	0
BLUE	BLUE(0)	0	0	0	0	0	0	0	0	0	0	0	0	0	0	0	0	0	0	0	0	0	0	0	0
	BLUE(1)	0	0	0	0	0	0	0	0	0	0	0	0	0	0	0	0	0	0	0	0	0	0	0	1
	BLUE(2)	0	0	0	0	0	0	0	0	0	0	0	0	0	0	0	0	0	0	0	0	0	0	1	0
	BLUE(253)	0	0	0	0	0	0	0	0	0	0	0	0	0	0	0	0	1	1	1	1	1	1	0	1
	BLUE(254)	0	0	0	0	0	0	0	0	0	0	0	0	0	0	0	0	1	1	1	1	1	1	1	0
	BLUE(255)	0	0	0	0	0	0	0	0	0	0	0	0	0	0	0	0	1	1	1	1	1	1	1	1

[Note]

(1) Definition of gray scale:

Color (n): n indicates gray scale level, higher n means brighter level.

(2)Data: 1-High, 0-Low

6. BLOCK DIAGRAM

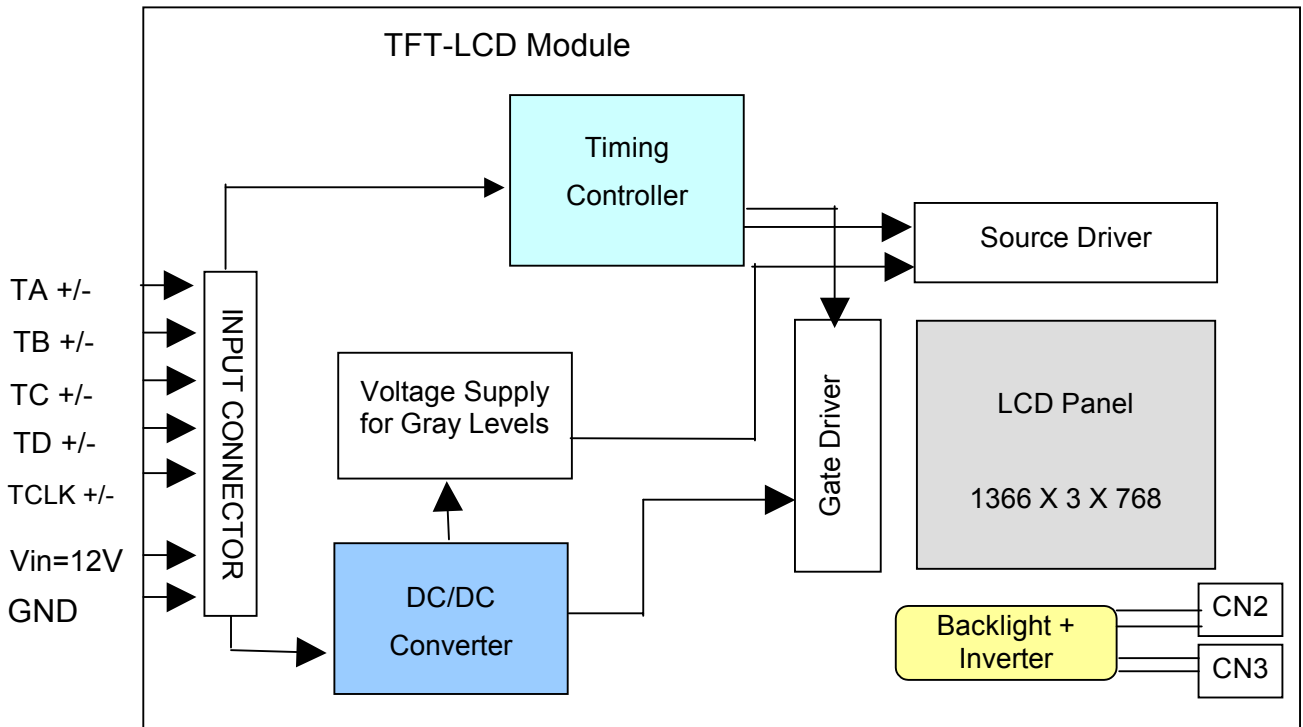

BACKLIGHT UNIT

Lamp connector

HV: BHR-02VS-1(JST)*8 or compatible

Mating connector: SM02 (8.0) B-BHS-1-TB (JST) or compatible

LV1: BHR-02VS-1 (JST)*1 or compatible

Mating connector: SM02 (8.0) B-BHS-1-TB (JST) or compatible

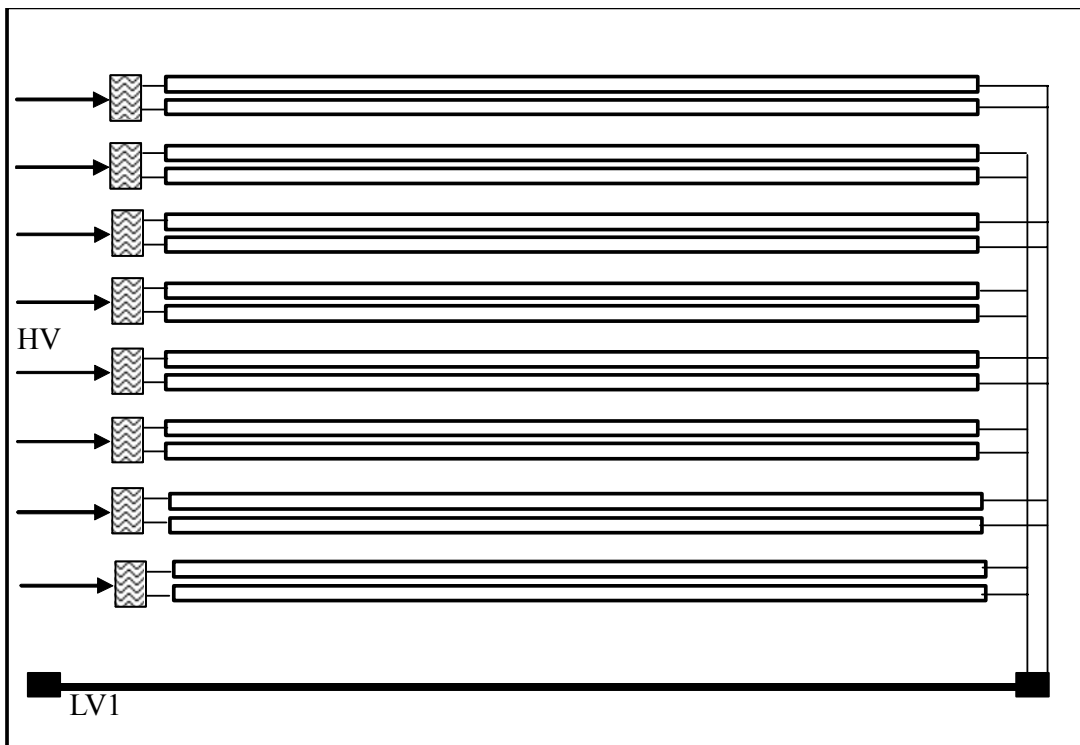

7. MECHANICAL SPECIFICATION

7.1 FRONT SIDE (include inverter, if the sizes of a panel don't show the differential value, please follow the values show as differential range table.)

[Unit: mm]

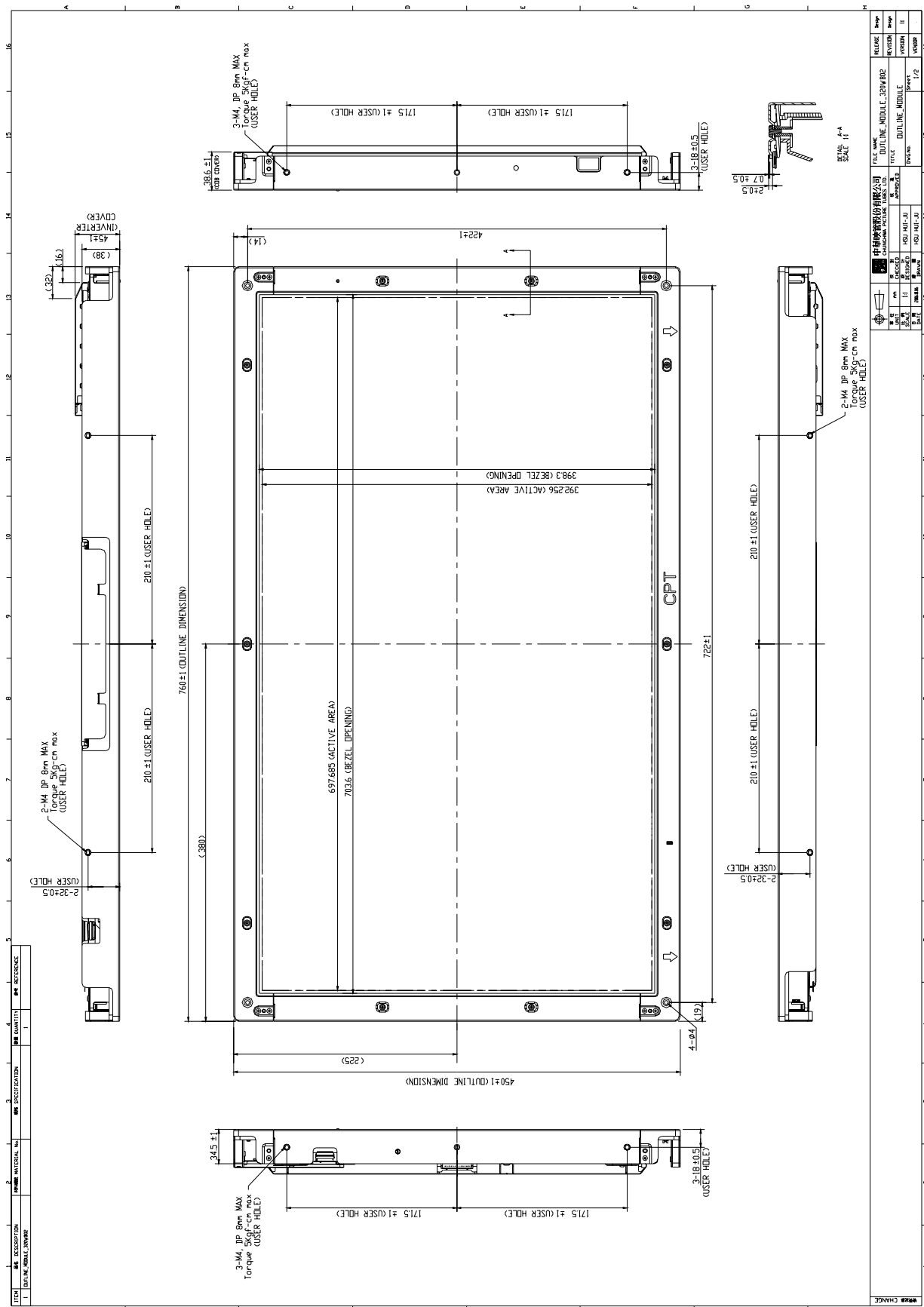

7.2 REAR SIDE

(include inverter, if the sizes of a panel don't show the differential value, please follow the values show as differential range table.)

[Unit: mm]

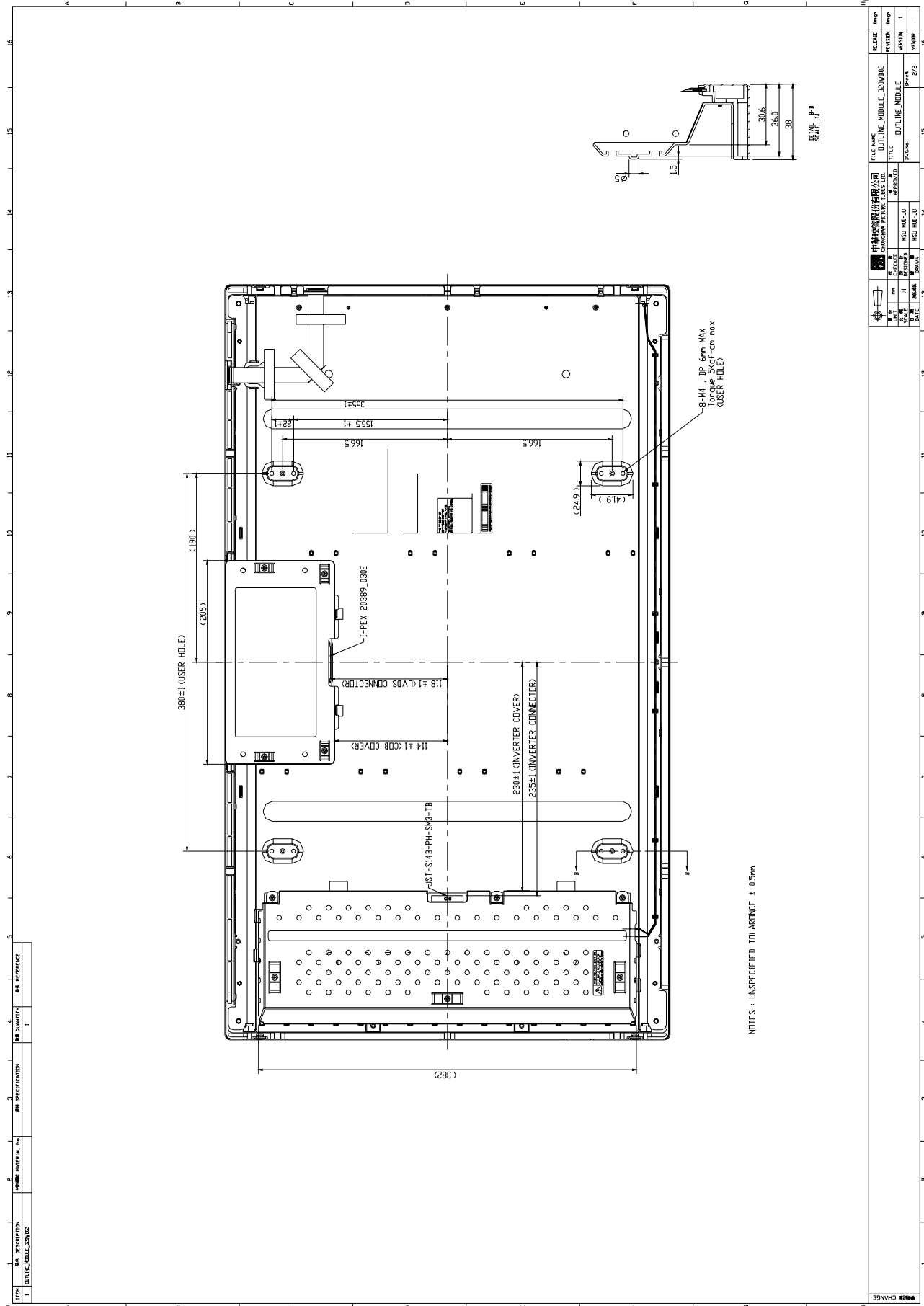

NOTES : UNSPECIFIED TOLARANCE ± 0.5mm

ITEM	DESCRIPTION	QUANTITY	REFERENCE
1	OUTLINE_MODULE	1	

		FILE NAME OUTLINE_MODULE_250WB02
TITLE OUTLINE_MODULE	PAGE NO. 2/2	RELEASE REVISION VERSION VENDOR
中國華映股份有限公司 CHUNG HWA PICTURE TUBES, LTD.	250WB02	16

8.OPTICAL CHARACTERISTICS

Ta = 25°C, VCC=12V ,Turn on for 30 minutes

ITEM		SYMBOL	CONDITION	MIN.	TYP.	MAX.	UNIT	Remarks
Contrast (CEN)		CR	$\theta = \psi = 0^\circ$ Point-5	800	1200	--	--	*1)*2)*3)
Luminance (CEN)	Central Luminance	Lwc	$\theta = \psi = 0^\circ$	400	500		cd/m ²	*7)
	5P Luminance (AVG)	Lw5	$\theta = \psi = 0^\circ$		450	--	cd/m ²	*2)*3)
Response Time (White – Black)		tr	$\theta = \psi = 0^\circ$	--	10	17	ms	*3)*4)
		tf	$\theta = \psi = 0^\circ$	--	6	8	ms	*3)*4)
Response Time (Gray to Gray Average)		trg , tfg	$\theta = \psi = 0^\circ$	--	8	15	ms	*5)
View Angle	Horizontal	ψ	CR \geq 20 Point-5	-80~80	-88~88	--	°	*2)*3)
	Vertical	θ		-80~80	-88~88	--	°	*2)*3)
Color Temperature Coordinate	Red	Rx	$\theta = \psi = 0^\circ$ Point-5	0.620	0.650	0.680	--	*2)*3)
		Ry		0.300	0.330	0.360		
	Green	Gx		0.240	0.270	0.300		
		Gy		0.590	0.620	0.650		
Blue	Bx	0.115	0.145	0.175				
	By	0.040	0.070	0.100				
White	Wx	0.253	0.283	0.313				
	Wy	0.267	0.297	0.327				
Color Temperature		Tc		--	9300	--	K	*3)
Color Gamut		CG		--	75	--	%	*6)

[Note]

These items are measured using: BM-5A (TOPCON)

View angle: EZ contrast XL-88, Response Time: Westar TRD-100

[under the dark room condition (no ambient light).]

Definition of these measurement items is as follows:

*1) Definition of Contrast Ratio:

$$CR = \text{ON (White) Luminance} / \text{OFF (Black) Luminance}$$

*2) Definition of Luminance, Luminance uniformity, Contrast, and the Deviation of Color Coordinate:

Luminance and Contrast: To measure at the center position "5" on the screen (NO.5), see Figure.8-1 below.

Luminance uniformity: Lw (MAX) and Lw(MIN) are the maximum and minimum luminance value measure at the position "1~5" on the screen (NO.1~5), see Figure.8-1 and below show equation:

$$\Delta Lw = [(Lw(\text{MIN})) / Lw(\text{MAX})] \times 100\%$$

The Deviation of Color Coordinate: To measure at the position "1~5" on the screen (NO.1~5), see Figure.8-1 below.

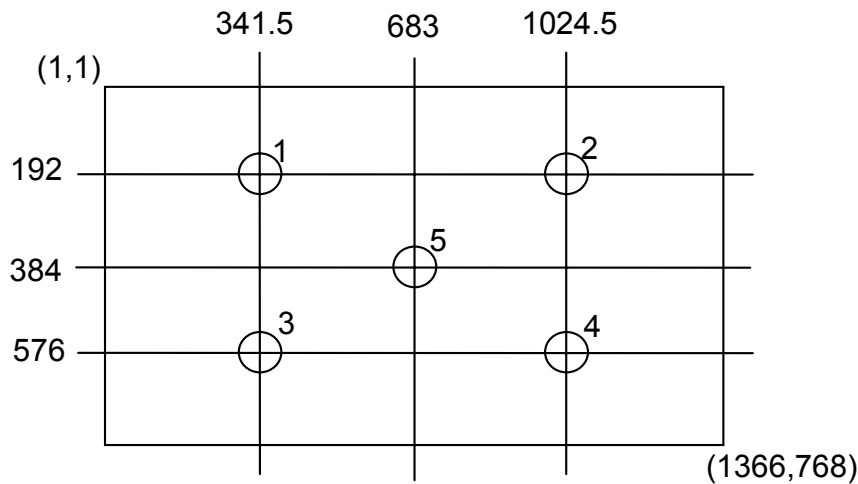

Figure 8-1. Measurement Positions

*3) Definition of Viewing Angle (θ , ϕ):

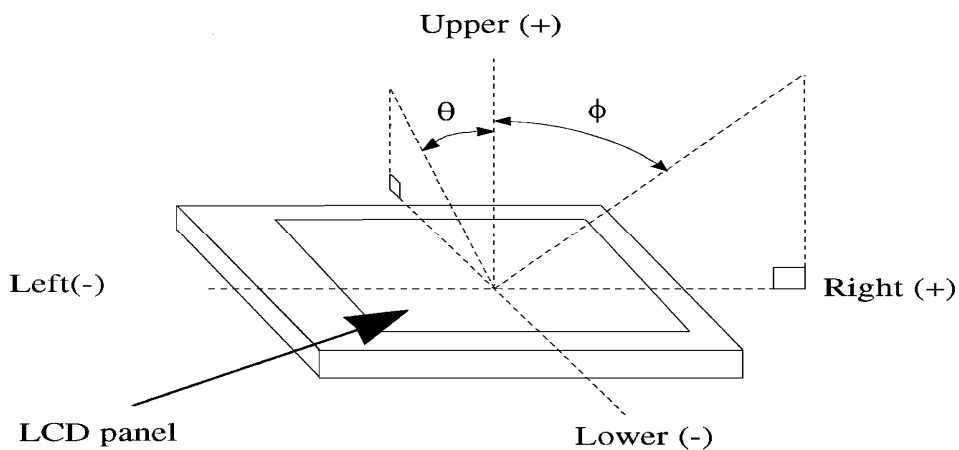

Figure 8-2. Definition of Viewing Angle

*4) Definition of Response Time (White – Black)

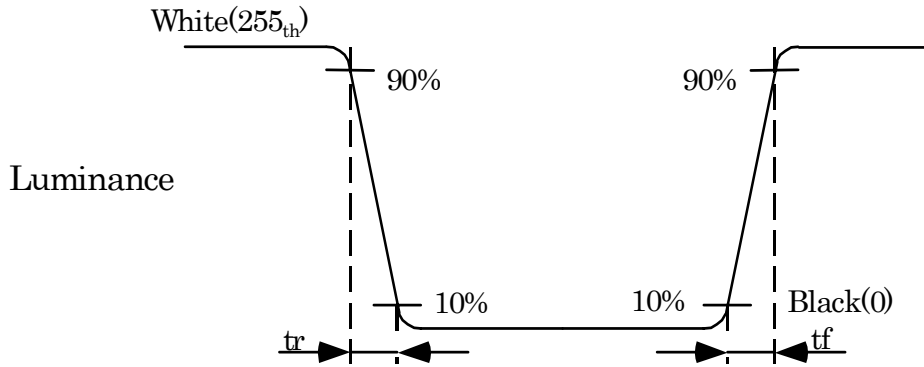

Figure 8-3. Definition of Response Time (White – Black)

*5) Definition of Response Time (Gray to Gray, Average)

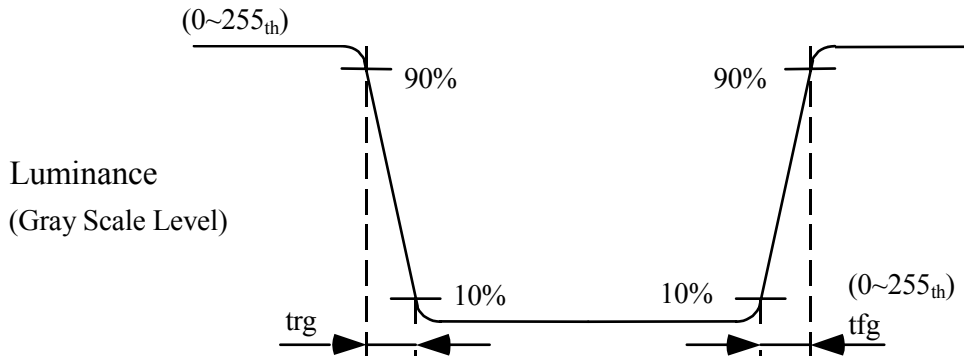

Figure 8-4. Definition of Response Time (Gray to Gray)

The driving signal time means the signal of gray level 0, 31, 63, 95, 127, 159, 191, 223, 255. Gray to gray average means the average switching time of gray level 0, 31, 63, 95, 127, 159, 191, 223, 255 to each other.

The LCD module should be stabilized at given temperature for 1 hour to avoid abrupt temperature change during measuring. In order to stabilize the luminance, the measurement should be executed after lighting Backlight for 1 hour in a windless room.

*6) Definition of Color Gamut:

To measure RGB three sub-pixels color gamut coordinate at CIE coordinate chart from the center of module, to form a triangle area = A_{RGB} .

RGB three sub-pixels of NTSC at CIE coordinate chart to form a triangle area = N_{RGB} .

$$CG = \frac{A_{RGB}}{N_{RGB}} \times 100$$

*7) Definition of Central Luminance:

After lighting on the panel 30 mins, you can proceed the Central Luminance testing. The definiton of Typ value is under status of Inverter Dimming Voltage=3.3V.

9.RELIABILITY TEST CONDITIONS

9.1 ENVIRONMENT TEST CONDITION

Test Item	Condition
High Temperature Operation	50°C; 240hrs
High Temperature Storage	60°C; 240hrs
High Temperature High Humidity Operation	50°C; 90% RH; 240 hrs (No condensation)
Low Temperature Operation	0°C; 240 hrs
Low Temperature Storage	-20°C; 240 hrs

9.2 SHOCK AND VIBRATION

Item	Condition
Shock (Non-Operation)	Shock level: 980m/s ² (100G) Waveform: half sinusoidal wave, 2ms Number of shocks: one shock input in each direction of three mutually perpendicular axes for a total of six shock inputs.
Vibration (Non-Operation)	Vibration level: 9.8m/s ² (1.0G) zero to peak Waveform: sinusoidal Frequency range: 10 to 300 Hz Frequency sweep rate: 0.5 octave/min Duration: each x, y, z axis: 10 min, total 30 mins

9.3 JUDGMENT STANDARD

The judgment of the above test should be made as follow:

Pass: Normal display image with no obvious non-uniformity and no line defect.

Partial transformation of the module parts shall be ignored.

Fail: No display, obvious non-uniformity, or line defects.

10. PACKAGING

10.1 PACKING SPECIFICATIONS

- (1) 4 LCD TV modules/1 Box
- (2) Box dimensions: 876(L) x 369(W) x 559(H)
- (3) Weight: approximately 34kg (4 modules per box)

10.2 PACKING METHOD

Figure 1 and Figure 2 are the packing method.

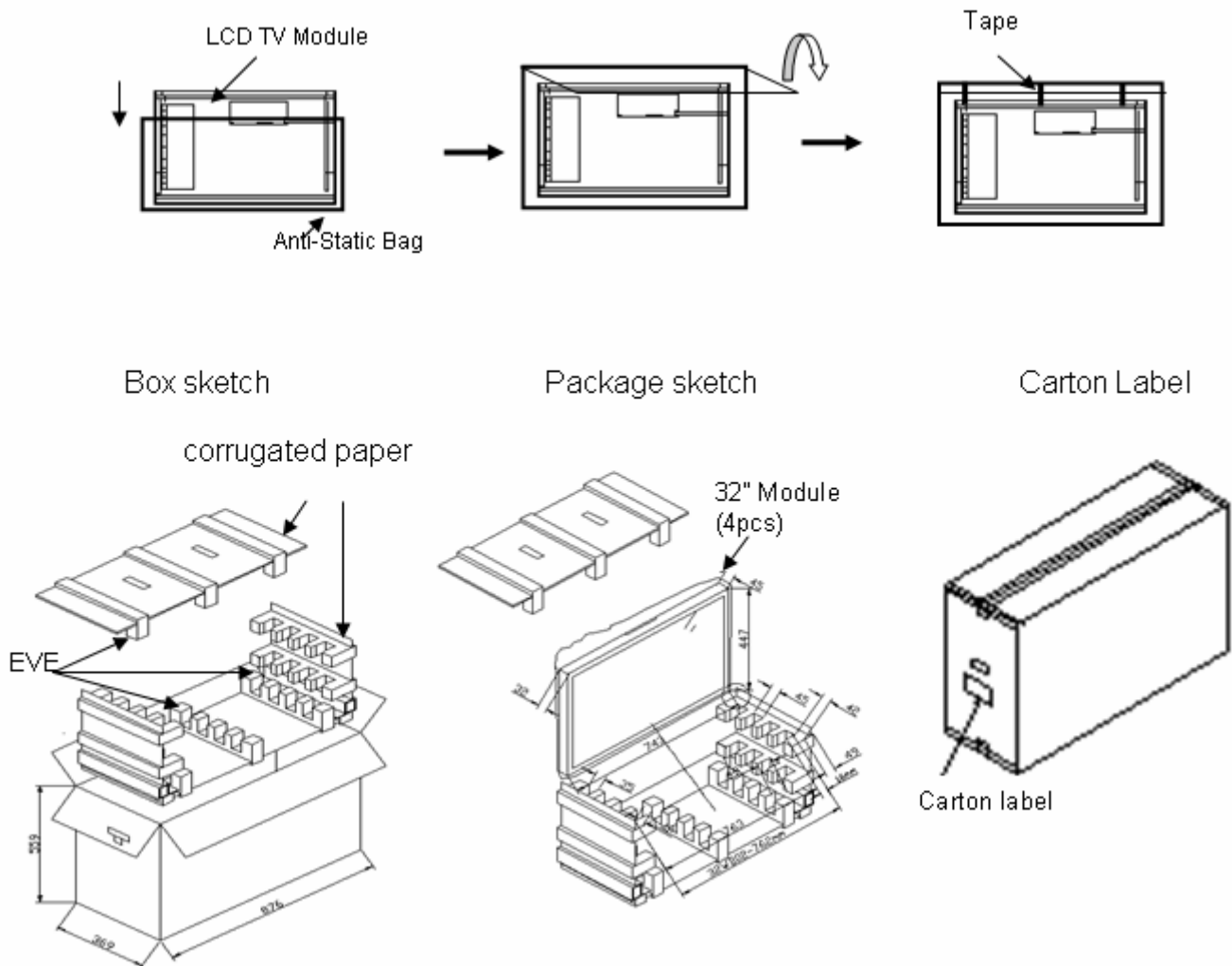

Figure 1 Packing Method

- (1) 6 Boxes/1Pallet
- (2) Corner protector: L1125 x 50mm x 50mm
- (3) Pallet: L900 x W1150 x H130mm
- (4) Bottom Cap: L900 x W1150 x H130mm
- (5) Gross: 214kg (24 modules per pallet)

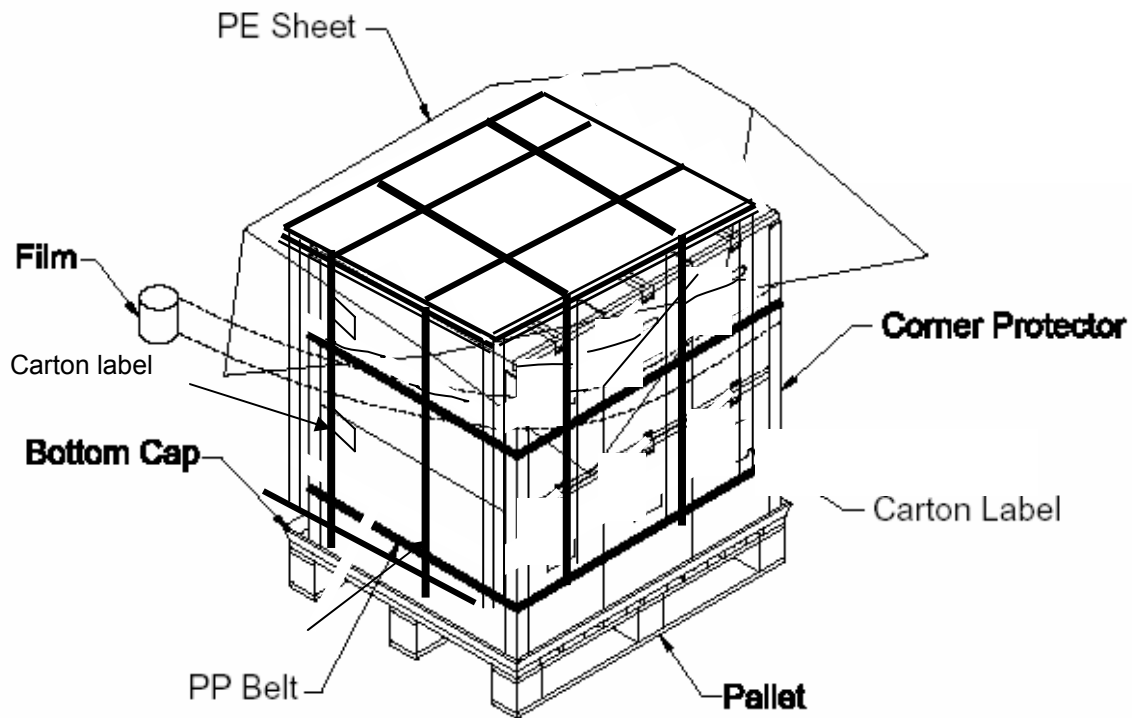

Figure 2 Packing Method

11. HANDLING PRECAUTIONS FOR TFT-LCD MODULE

Please pay attention to the followings in handling TFT-LCD products.

11.1 ASSEMBLY PRECAUTION

- (1) Please use the mounting hole on the module side in installing and do not beading or wrenching LCD in assembling. And please do not drop, bend or twist LCD module in handling.
- (2) Please design display housing in accordance with the following guidelines.
 - Housing case must be destined carefully and do not to put stresses on LCD all sides or wrench module. The stresses may cause non-uniformity even if there is no non-uniformity statically.
 - Keep sufficient clearance between LCD module back surface and housing when the LCD module is mounted. Approximately 1.0 mm of the clearance in the design is recommended taking into account the tolerance of LCD module thickness and mounting structure height on the housing.
 - When some parts, such as, FPC cable and ferrite plate, are installed underneath the LCD module, still sufficient clearance is required, such as 0.5mm. This clearance is, especially, to be reconsidered when the additional parts are implemented for EMI countermeasure.
 - Design the inverter location and connector position carefully so as not to put stress on lamp cable.
 - Keep sufficient clearance between LCD module and the other parts, such as inverter and speaker so as not to interface the LCD module. Approximately 1.0mm of the clearance in the design is recommended.
- (3) Please do not push or scratch LCD panel surface with any-thing hard. And do not soil LCD panel surface by touching with bare hands. (Polarizer film and surface of LCD panel are easy to be flawed.)
- (4) Please do not press any parts on the rear side such as source TCP, gate TCP, control circuit board and FPC during handling the LCD module. If pressing rear part could not be avoided, handle the LCD module with care not to damage them.
- (5) Please wipe out LCD panel surface with absorbent cotton or soft clothe in case of it being soiled.
- (6) Please wipe out drops of adhesives like saliva and water on LCD panel surface immediately. They might damage to cause panel surface variation and color change.
- (7) Please do not take a LCD module to pieces and reconstruct it. Resolving and reconstructing modules may cause them not to work well.
- (8) Please do not touch metal frames with bare hands and soiled gloves. A color change of the metal frames can happen during a long preservation of soiled LCD modules.

- (9) Please pay attention to handling lead wire of backlight so that it is not tugged in connecting with inverter.

11.2 OPERATING PRECAUTIONS

- (1) Please be sure to turn off the power supply before connecting and disconnecting signal input cable.
- (2) Please do not change variable resistance settings in LCD module. They are adjusted to the most suitable value. If they are changed, it might happen LCD does not satisfy the characteristics specification.
- (1) Please consider that LCD backlight takes longer time to become stable of radiation characteristics in low temperature than in room temperature.
- (2) A condensation might happen on the surface and inside of LCD module in case of sudden change of ambient temperature.
- (3) Please pay attention to displaying the same pattern for a very long time. Image might stick on LCD. If then, time going on can make LCD work well.
- (4) Please obey the same caution descriptions as ones that need to pay attention to ordinary electronic parts.

11.3 PRECAUTIONS WITH ELECTROSTATICS

- (1) This LCD module use CMOS-IC on circuit board and TFT-LCD panel, and so it is easy to be affected by electrostatics. Please be careful with electrostatics by the way of your body connecting to the ground and so on.
- (2) Please remove protection film very slowly on the surface of LCD module to prevent from electrostatics occurrence.

11.4 STORAGE PRECAUTIONS

- (1) When you store LCD for a long time, it is recommended to keep the temperature between 0°C ~40°C without the exposure of sunlight and keep the humidity less than 90%RH.
- (2) Please do not leave the LCD in the environment of high humidity and high temperature such as 60°C 90%RH.
- (3) Please do not leave the LCD in the environment of low temperature(can not lower than -20°C).

11.5 SAFETY PRECAUTIONS

- (1) When you waste LCD, it is recommended to crush damaged or unnecessary LCD into pieces and wash them off with solvents such as acetone and ethanol, which should later be burned.
- (2) If any liquid leaks out of a damaged-glass cell and comes in contact with the hands, wash off thoroughly with soap and water.

11.6 OTHERS

- (1) A strong incident light into LCD panel might cause display characteristics' changing inferior because of polarizer film, color filter, and other materials becoming inferior. Please do not expose LCD module direct sunlight and strong UV rays.
- (2) Please pay attention on the side of LCD module do not contact with other materials in preserving it alone.
- (3) For the packaging box, please pay attention to the followings:
 - Packaging box and inner case for LCD are designed to protect the LCD from the damage or scratching during transportation. Please do not open except picking LCD up from the box.
 - Please do not pile them up more than 3 boxes. (They are not designed so.) And please do not turn over.
 - Please handle packaging box with care not to give them sudden shock and vibrations. And also please do not throw them up.
 - Packing box and inner case for LCD are made of cardboard. So please pay attention not to get them wet. (Such as keep them away from high humidity or wet place.)