



Chunghwa Picture Tubes, Ltd.

Technical Specification

Date : 2008.01.03

CPT TFT-LCD

CLAA370WA03 SC

ACCEPTED BY :

APPROVED BY	CHECKED BY	PREPARED BY
Steve Sun	溫文良	Product Planning Management General Division

Product Planning Management General Division

CHUNGHWA PICTURE TUBES, LTD.

1127 Hopin Rd., Padeh, Taoyuan, Taiwan 334, R.O.C.

TEL: +886-3-3675151 FAX: +886-3-377-3054

Doc.No: CLAA370WA03_SC-SPEC-20080103

Issue Date: 2008/01/03

T- 3650002- 000- A NEW

CONTENTS

No	Item	Page
1	OVERVIEW	3
2	ABSOLUTE MAXIMUM RATINGS	4
3	TFT-LCD MODULE	5
4	INTERFACE PIN CONNECTION	9
5	INTERFACE TIMING	12
6	BLOCK DIAGRAM	17
7	MECHANICAL SPECIFICATION	18
8	OPTICAL CHARACTERISTICS	20
9	RELIABILITY	21
10	HANDLING PRECAUTIONS FOR TFT-LCD MODULE	22

1. OVERVIEW

CLAA370WA03 SC is 37" color (94.03cm) TFT-LCD (Thin Film Transistor Liquid Crystal Display) module composed of LCD panel, LVDS driver ICs, control circuit, backlight, and inverter. By applying 8 bit digital data, 1366*768, 16.7 million-color images are displayed on the 37" diagonal screen. General specification are summarized in the following table:

ITEM		SPECIFICATION	UNIT
Display Area		819.6(H) × 460.8(V) (37.02 inch diagonal)	mm
Number of Pixels		1366 (H) × 768 (V)	16:9
Pixel Pitch		0.6 (H) × 0.6 (V)	mm
Bezel Opening Area		826.6 x 467.8	mm
Color Pixel Arrangement		RGB Vertical Strip	
Display Mode		Normally Black	
Number of Colors		16.7M (8bits)	color
Wide View Tech.		MVA	
Electrical Interface		LVDS	
Total Module Power		127 (Typ.) (B/L with inverter120W)	W
Module Outline Dimension	Horizontal(H)		877 (Typ)
	Vertical(V)		514.6 (Typ)
	Depth(D)	without inverter	45.1 (Typ)
		with inverter	55.3 (Typ)
Module Weight		12000 (Typ)	g
Backlight Unit		CCFL, 16 tables	
Surface Treatment		Hard coating: 3H	

2. ABSOLUTE MAXIMUM RATINGS

The following are maximum values which, if exceeded, may cause faulty operation or damage to the Unit.

ITEM	SYMBOL	MIN.	MAX.	UNIT	REMARK
Power Supply Voltage For LCD	VCC	-0.3	14.0	V	
Input voltage of inverter	VBL	-0.3	27.0	V	
Inverter dimming	VDIM	-0.3	3.5	Vdc	
Backlight on/off	VBLON	-0.3	5.5	Vdc	
ESD for Connector	VESD	-250	250	V	
ESD for Module	VESD	-15	15	KV	
Operation Ambient	Top	0	50		*1) *2) *3) *4)
Storage Temperature	Tstg	-20	60		*1) *2) *3) *4)

[Note]

- *1) The relative temperature and humidity range are as below sketch.(90%RHMax / Ta 40)
- *2) The maximum wet bulb temperature 39 (Ta > 40) and without dewing.
- *3) If you use the product in a environment which over the definition of temperature and humidity too long, and it will effect the result of visible inspection.
- *4) While the product operates in normal temperature range, the center surface of panel should be under 60 .
- *5) Input voltage of the connector side in Inverter.

Humidity:

Humidity 85%RH without condensation.

Relative Humidity 90% (Ta 40)

Wet Bulb Temperature 39 (Ta 40)

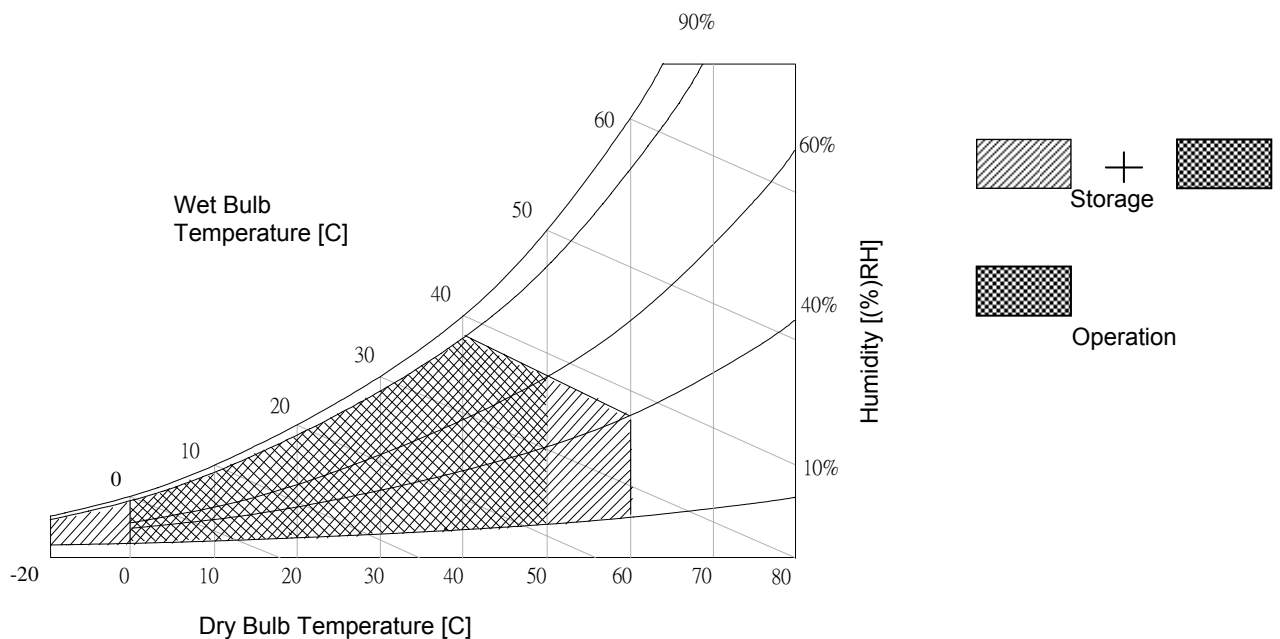

3. ELECTRICAL CHARACTERISTICS

3.1 TFT-LCD MODULE

Ta=25

ITEM	SYMBOL	MIN	TYP	MAX	UNIT	REMARK
LCD Power Supply Voltage	VCC	10.8	12.0	13.2	V	*1)
Ripple Voltage	Vrpd	--	--	100	mVp-p	VCC=+12.0V
Rush Current	Irush	--	--	3	A	*2)
LCD Power Supply Current	White	--	540	--	mA	*3)
	Black	--	400			
	RGB stripe	--	570			
LCD Power Consumption	Pc	--	7.0	10.0	W	
High Input Voltage of LVDS	V _{IN+}	--	--	100	mV	*4) *5)
Low Input Voltage of LVDS	V _{IN-}	100	--	--	mV	
Input Common Voltage of LVDS	VCM	--	1.25	-	V	
Input Terminal Resister of LVDS	R _T	--	100	--	ohm	

[Note]

*1) The module should be always operated within above ranges.

*2) Measure conditions:

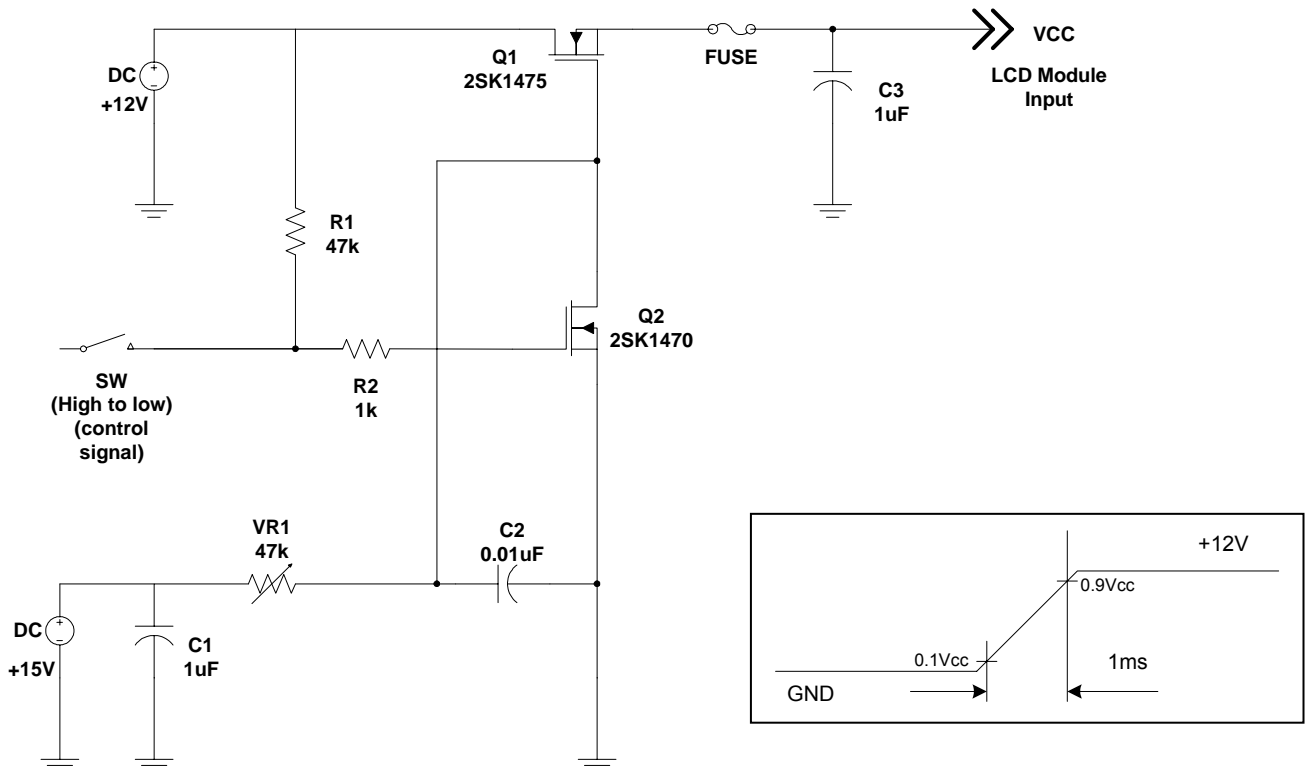

Vcc rising time is 1 ms

*3) The specified power supply current is under condition at $V_{cc}=12V$, $T_a=25\pm 2$, $f_v=60Hz$, whereas a power dissipation check pattern below is displayed.

a. White pattern



b. Black pattern

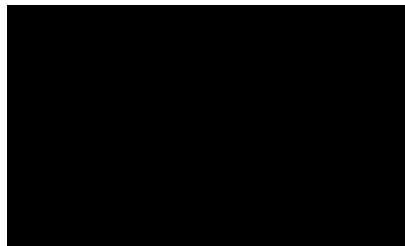

c. RGB Stripe pattern

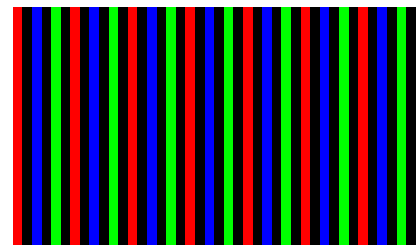

*4) Power and Signal Sequence:

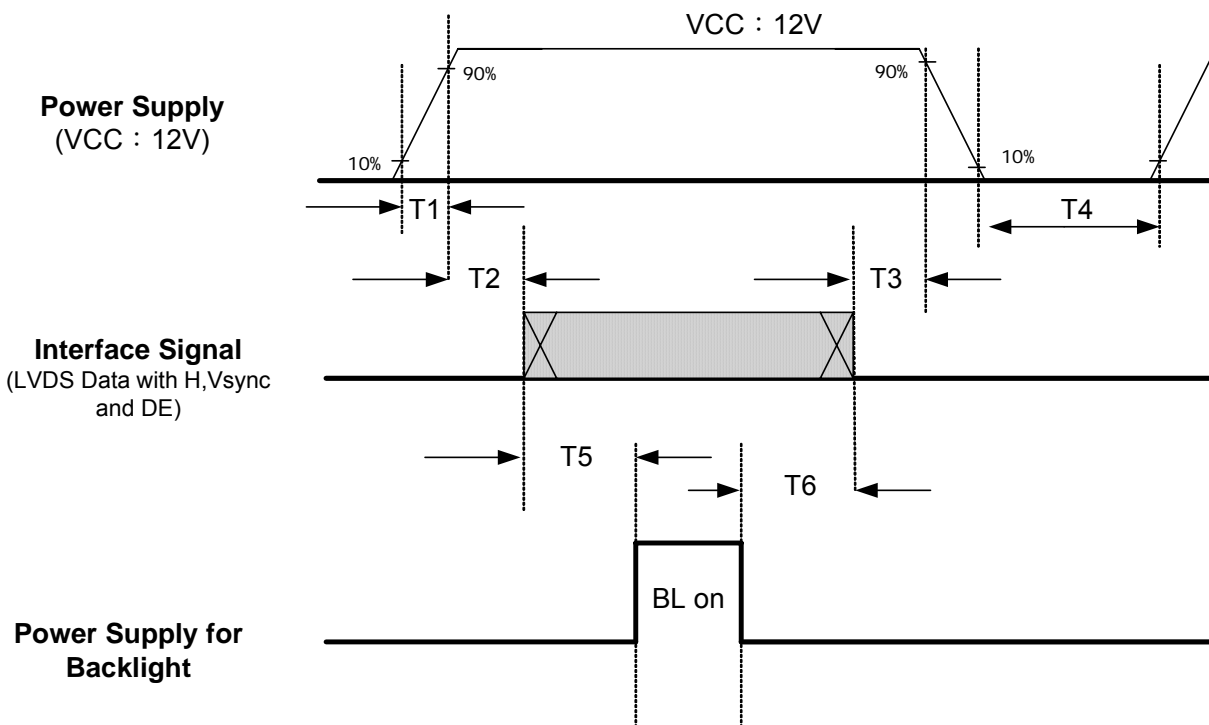

Power Sequence Table

Parameter	Value			Unit
	Min	Typ	Max	
T1	1	---	30	ms
T2	0	---	50	ms
T3	0	---	50	ms
T4	2000	---		ms
T5	110	---		ms
T6	100	---		ms

Notes:

- Please avoid floating state of interface signal at invalid period.
- When the interface signal is invalid, be sure to pull down the power supply for LCD to 0V.
- Lamp power must be turn off after power supply for LCD interface signal valid.

VCC-dip State:

- 1) When $9V < VCC < 11.4V$, $t_d = 10\text{ ms}$.
- 2) $VCC > 11.4V$, VCC-dip condition should also follow the VCC-turn-off condition.

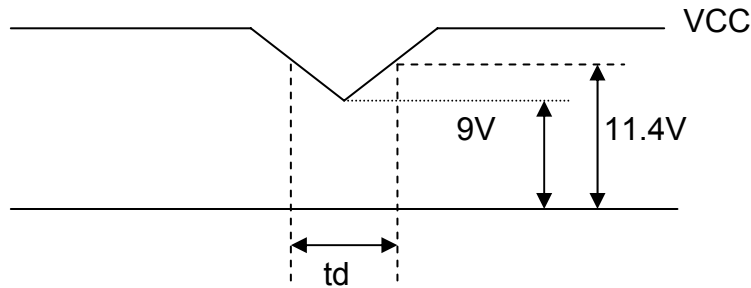

*5) LVDS Signal Definition:

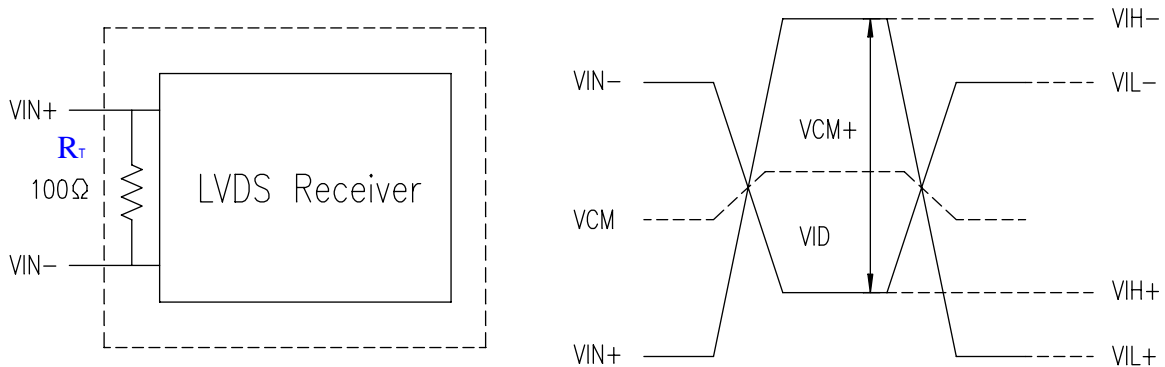

$$VID = VIN_+ - VIN_-$$

$$VCM = |VCM_+ - VCM_-|$$

$$VID = |VID_+ - VID_-|$$

$$VID_+ = |VIH_+ - VIH_-|$$

$$VID_- = |VIL_+ - VIL_-|$$

$$VCM = (VIN_+ + VIN_-) / 2$$

$$VCM_+ = (VIH_+ + VIH_-) / 2$$

$$VCM_- = (VIL_+ + VIL_-) / 2$$

VIN+: Positive Polarity differential DATA & CLK input

VIN-: Negative Polarity differential DATA & CLK input

3.2 BACKLIGHT

Ta = 25°C, VCC=12V, Turn on for 30 minutes

ITEM	SYMBOL	MIN	TYP	MAX	UNIT	REMARK	
Lamp Life Time	LT	50000	--	--	hr	*1)	
Input Voltage of Inverter	VBL	21.6	24	26.4	V	*2)	
Input Current of Inverter	IIN	--	5	6	A	*3)	
Internal PWM with Analog Input Dimming Control Voltage	IPW	0	--	3.3	V	*4)	
Duty Ratio	D	20	--	100	%		
Backlight on /off Control Voltage	ON	Von/off	2.0	--	5.0	V	
	OFF		0	--	0.8		
Power Consumption (Backlight)	BLW	--	120	144	W	*3)	

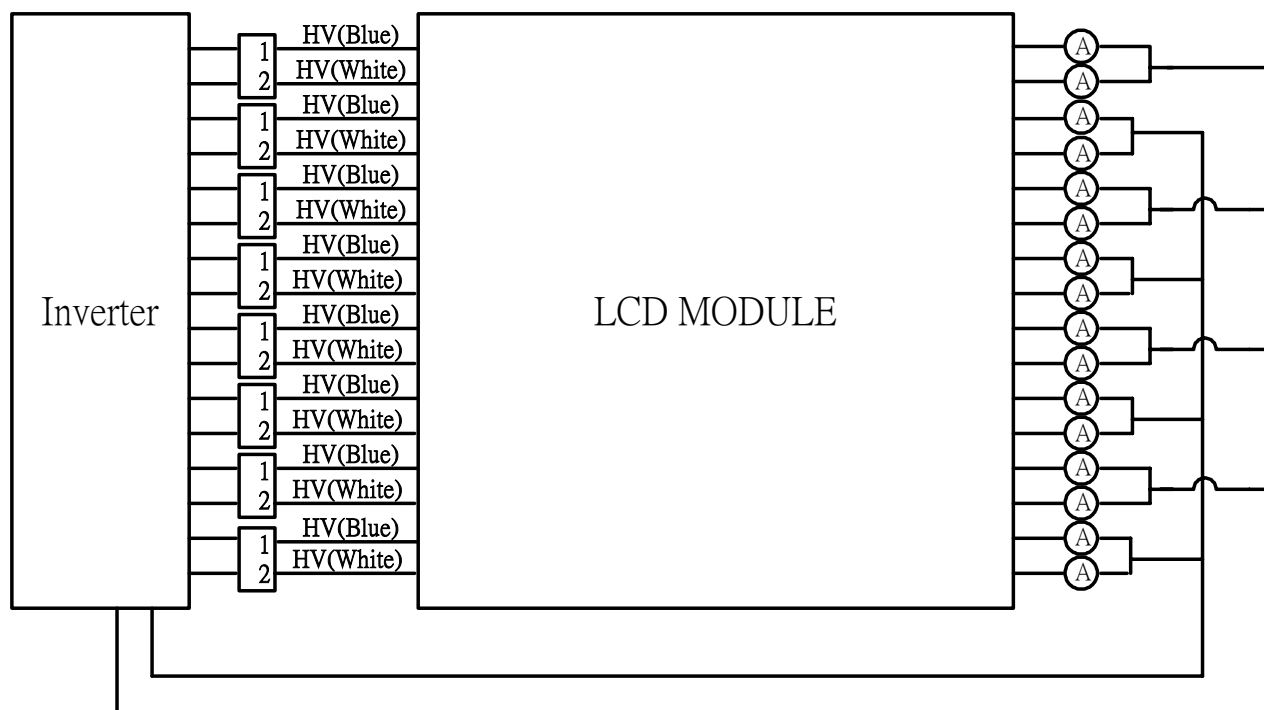

[Note]

*1) Definition of the lamp life time:

When lamp luminance reduce to 50% or lower than its initial value.

*2) Ripple voltage that occur at the instant of power-on can't exceed 27V.

*3) 25 ; IPW=3.3V(Max.), after power on for 30 Minutes; Max value of the power consumption and input current is measured at initial turn on of the backlight.

*4) Internal PWM control with Analog input voltage.

Brightness is the darkest when IPW = 0V;

Brightness is the brightest when IPW = 3.3V.

4. INTERFACE PIN CONNECTION

4.1 Connector Part No.: FI-E30S(JAE)

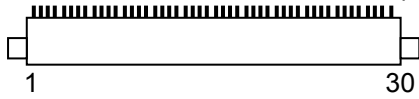

Pin NO	Symbol	Description	Note
1	VCC	Power supply: +12V	
2	VCC	Power supply: +12V	
3	VCC	Power supply: +12V	
4	VCC	Power supply: +12V	
5	GND	Ground	
6	GND	Ground	
7	GND	Ground	
8	GND	Ground	
9	DMS	LVDS Data Mapping Select	*2)
10	NC	NC	*1)
11	GND	Ground	
12	RxIN0-	Data-	
13	RxIN0+	Data+	
14	GND	Ground	
15	RxIN1-	Data-	
16	RxIN1+	Data+	
17	GND	Ground	
18	RxIN2-	Data-	
19	RxIN2+	Data+	
20	GND	Ground	
21	RxCLKIN-	Clock-	
22	RxCLKIN+	Clock+	
23	GND	Ground	
24	RxIN3-	Data-	
25	RxIN3+	Data+	
26	GND	Ground	
27	NC	NC	*1)
28	NC	NC	*1)
29	GND	Ground	
30	GND	Ground	

[Note]

*1) Reserved for internal use. Must be open.

*2) LVDS OPTION (DMS)

DMS(Pin 9)	LVDS format
GND/NC	No-JEIDA
3.3V	JEIDA

4.2 LVDS Data Mapping

Pin 9: GND/NC, Non-JEIDA mode

Non-JEIDA SPEC

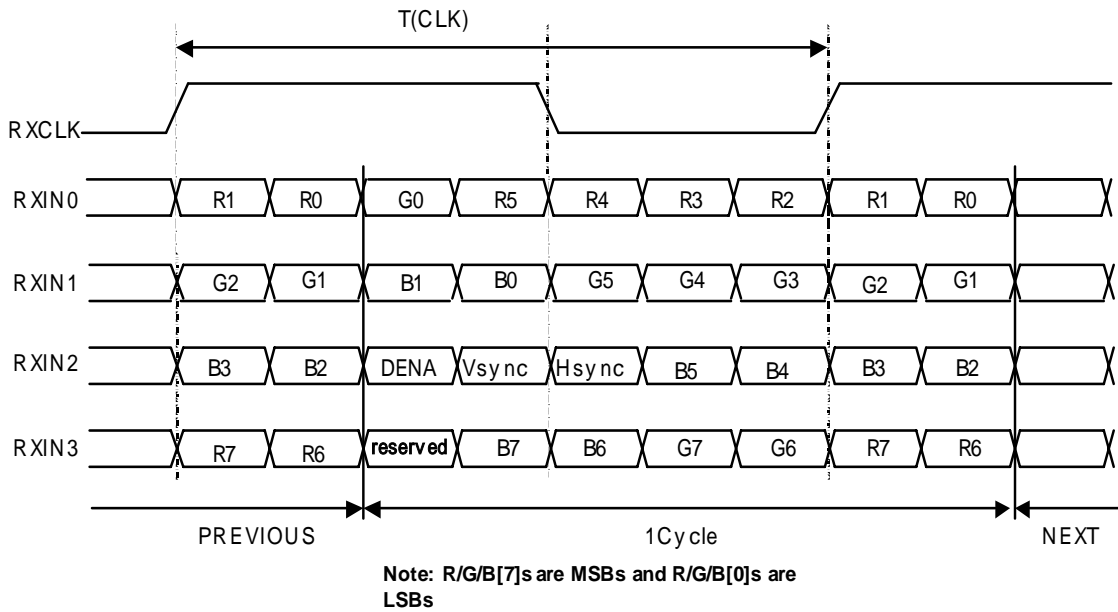

Pin 9: 3.3V, JEIDA mode

JEIDA SPEC

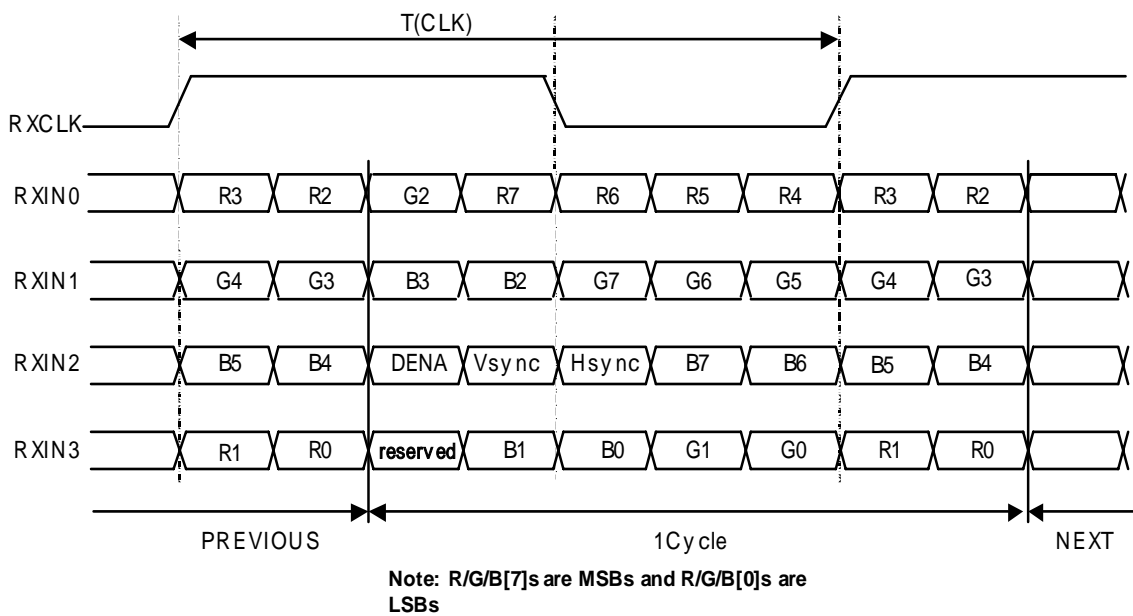

4.3 LVDS INTERFACE:

LVDS Receiver, Tcon (LVDS Rx merged)

	LVDS pin	JEIDA-DATA	Non-JEIDA-DATA
TxOUT/RxIN0	TxIN/RxOUT0	R2	R0
	TxIN/RxOUT1	R3	R1
	TxIN/RxOUT2	R4	R2
	TxIN/RxOUT3	R5	R3
	TxIN/RxOUT4	R6	R4
	TxIN/RxOUT6	R7	R5
	TxIN/RxOUT7	G2	G0
TxOUT/RxIN1	TxIN/RxOUT8	G3	G1
	TxIN/RxOUT9	G4	G2
	TxIN/RxOUT12	G5	G3
	TxIN/RxOUT13	G6	G4
	TxIN/RxOUT14	G7	G5
	TxIN/RxOUT15	B2	B0
	TxIN/RxOUT18	B3	B1
TxOUT/RxIN2	TxIN/RxOUT19	B4	B2
	TxIN/RxOUT20	B5	B3
	TxIN/RxOUT21	B6	B4
	TxIN/RxOUT22	B7	B5
	TxIN/RxOUT24	Hsync	Hsync
	TxIN/RxOUT25	Vsync	Vsync
	TxIN/RxOUT26	DENA	DENA
TxOUT/RxIN3	TxIN/RxOUT27	R0	R6
	TxIN/RxOUT5	R1	R7
	TxIN/RxOUT10	G0	G6
	TxIN/RxOUT11	G1	G7
	TxIN/RxOUT16	B0	B6
	TxIN/RxOUT17	B1	B7
	TxIN/RxOUT23	Reserved	Reserved

4.4 INVERTER - CONNECTOR

Connector (Receptacle): 20022WR-14AML (YEOAHO) or compatible.

Mating Connector (Plug): 20022HS-14L (YEONHO) or compatible.

Pin No.	Symbol	Description	Note
1	VBL	Supply Voltage 24V	
2	VBL	Supply Voltage 24V	
3	VBL	Supply Voltage 24V	
4	VBL	Supply Voltage 24V	
5	VBL	Supply Voltage 24V	
6	GND	Ground	
7	GND	Ground	
8	GND	Ground	
9	GND	Ground	
10	GND	Ground	
11	NC	NC	
12	B/L ON/ OFF	B/L On: NC /High (2.0~5.0V) B/L Off: GND (0~0.8V)	
13	IPW	Internal PWM with analog input (Max:3.3V; Min:0V)	*1)
14	NC	NC	

[Note]

*1) Internal PWM is DC level signal using Saw Tooth Wave control.

5. INTERFACE TIMING (DE mode only)

5.1 TIMING SPECIFICATION

Signal	Item	Symbol	Min	Typ	Max	Unit	Note
Clock	Frequency	1/Tc	58.4	80	84	MHz	
Vertical Active Display Term	Frame Rate	Fr	47	60	63	Hz	
	Total	Tv	790	810	888	Th	Tv=Tvd+Tvb
	Display	Tvd	768	768	768	Th	
Horizontal Active Display Term	Blank	Tvb	22	42	120	Th	
	Total	Th	1575	1648	1936	Tc	Th=Thd+Thb
	Display	Thd	1366	1366	1366	Tc	
Horizontal Active Display Term	Blank	Thb	209	282	570	Tc	

5.2 TIMING CHART

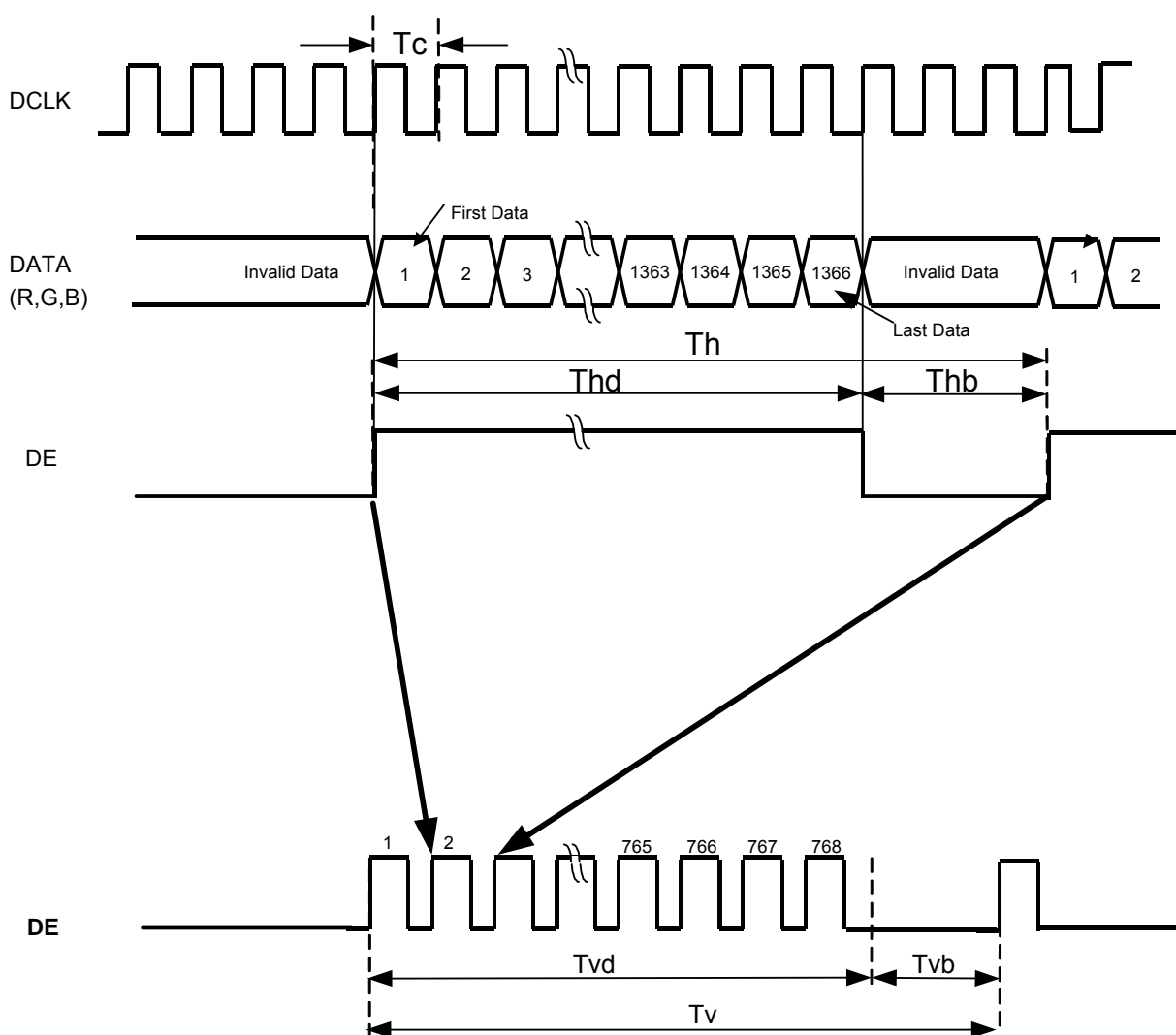

5.3 COLOR DATA ASSIGNMENT

Data	INPUT Data	R Data								G Data								B Data							
		R7	R6	R5	R4	R3	R2	R1	R0	R7	R6	R5	R4	R3	R2	R1	R0	R7	R6	R5	R4	R3	R2	R1	R0
		MSB							LSB	MSB							LSB	MSB							LSB
BASIC COLOR	BLACK	0	0	0	0	0	0	0	0	0	0	0	0	0	0	0	0	0	0	0	0	0	0	0	0
	RED(255)	1	1	1	1	1	1	1	1	0	+	0	0	0	0	0	0	0	0	0	0	0	0	0	0
	GREEN(255)	0	0	0	0	0	0	0	0	1	1	1	1	1	1	1	1	0	0	0	0	0	0	0	0
	BLUE(255)	0	0	0	0	0	0	0	0	0	0	0	0	0	0	0	0	1	1	1	1	1	1	1	1
	CYAN	0	0	0	0	0	0	0	0	1	1	1	1	1	1	1	1	1	1	1	1	1	1	1	1
	MAGENTA	1	1	1	1	1	1	1	1	0	0	0	0	0	0	0	0	1	1	1	1	1	1	1	1
	YELLOW	1	1	1	1	1	1	1	1	1	1	1	1	1	1	1	1	0	0	0	0	0	0	0	0
	WHITE	1	1	1	1	1	1	1	1	1	1	1	1	1	1	1	1	1	1	1	1	1	1	1	1
RED	RED(0)	0	0	0	0	0	0	0	0	0	0	0	0	0	0	0	0	0	0	0	0	0	0	0	0
	RED(1)	0	0	0	0	0	0	0	1	0	0	0	0	0	0	0	0	0	0	0	0	0	0	0	0
	RED(2)	0	0	0	0	0	0	1	0	0	0	0	0	0	0	0	0	0	0	0	0	0	0	0	0
	RED(253)	1	1	1	1	1	1	0	1	0	0	0	0	0	0	0	0	0	0	0	0	0	0	0	0
	RED(254)	1	1	1	1	1	1	1	0	0	0	0	0	0	0	0	0	0	0	0	0	0	0	0	0
	RED(255)	1	1	1	1	1	1	1	1	0	0	0	0	0	0	0	0	0	0	0	0	0	0	0	0
GREEN	GREEN(0)	0	0	0	0	0	0	0	0	0	0	0	0	0	0	0	0	0	0	0	0	0	0	0	0
	GREEN(1)	0	0	0	0	0	0	0	0	0	0	0	0	0	0	1	0	0	0	0	0	0	0	0	0
	GREEN(2)	0	0	0	0	0	0	0	0	0	0	0	0	0	0	1	0	0	0	0	0	0	0	0	0
	GREEN(253)	0	0	0	0	0	0	0	0	1	1	1	1	1	1	0	1	0	0	0	0	0	0	0	0
	GREEN(254)	0	0	0	0	0	0	0	0	1	1	1	1	1	1	1	0	0	0	0	0	0	0	0	0
	GREEN(255)	0	0	0	0	0	0	0	0	1	1	1	1	1	1	1	1	0	0	0	0	0	0	0	0
BLUE	BLUE(0)	0	0	0	0	0	0	0	0	0	0	0	0	0	0	0	0	0	0	0	0	0	0	0	0
	BLUE(1)	0	0	0	0	0	0	0	0	0	0	0	0	0	0	0	0	0	0	0	0	0	0	0	1
	BLUE(2)	0	0	0	0	0	0	0	0	0	0	0	0	0	0	0	0	0	0	0	0	0	0	1	0
	BLUE(253)	0	0	0	0	0	0	0	0	0	0	0	0	0	0	0	0	1	1	1	1	1	1	0	1
	BLUE(254)	0	0	0	0	0	0	0	0	0	0	0	0	0	0	0	0	1	1	1	1	1	1	1	0
	BLUE(255)	0	0	0	0	0	0	0	0	0	0	0	0	0	0	0	0	1	1	1	1	1	1	1	1

[Note]

1) Definition of gray scale:

Color (n): n indicates gray scale level, higher n means brighter level.

2) Data: 1-High level voltage, 0-Low level voltage

6. BLOCK DIAGRAM

6.1 TFT LCD MODULE

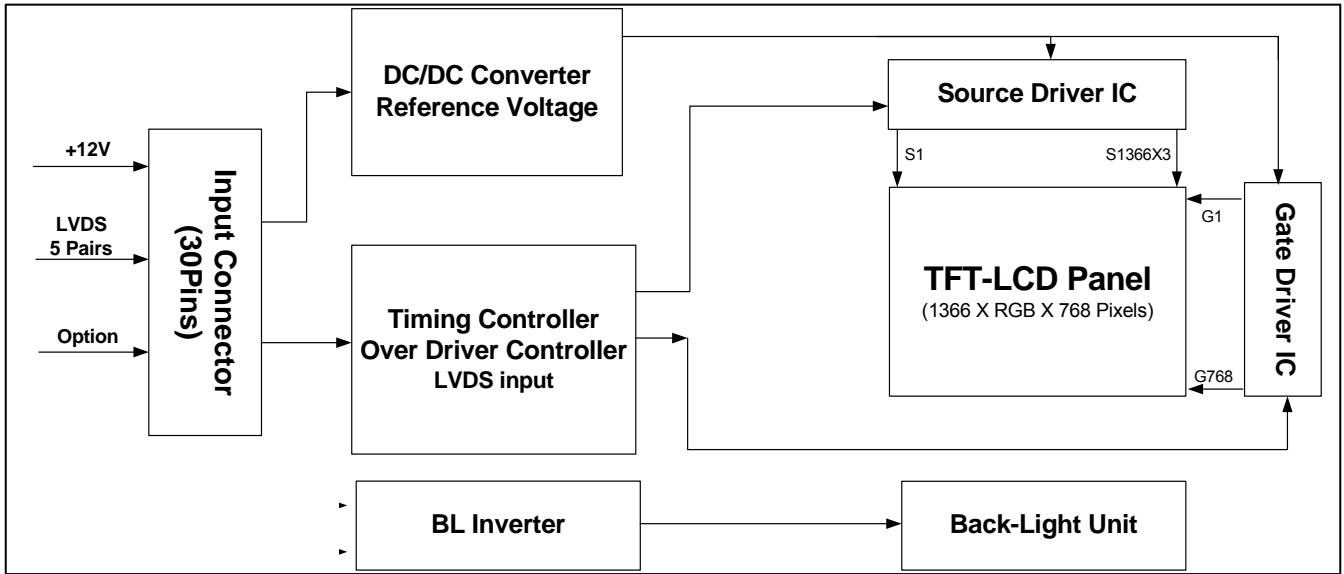

6.2 BACKLIGHT UNIT

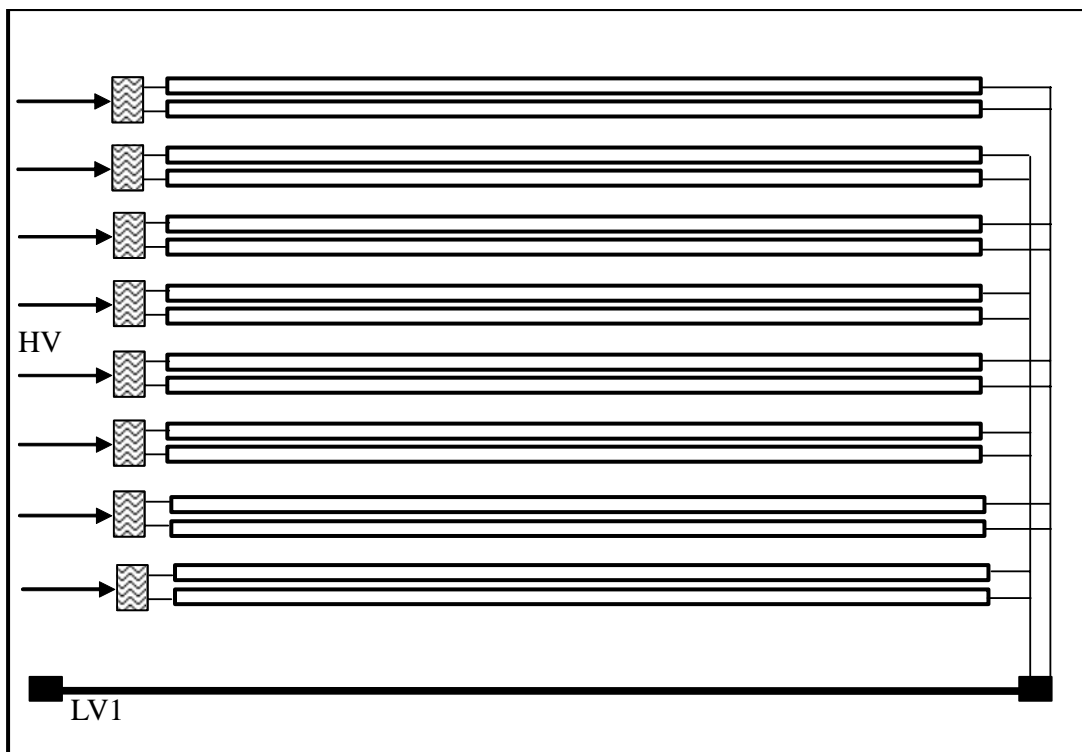

[Note] Lamp Connector

HV: 20015WR-05L00 (YEONHO)*8 or compatible

Mating connector: 20015HS-03L (YEONHO) or compatible

LV1: 20015WR-05L00 (YEONHO) or compatible

Mating connector: 20015HS-03L(YEONHO) or compatible

8.OPTICAL CHARACTERISTICS

Ta = 25°C, VCC=12V, Turn on for 30 minutes

ITEM	SYMBOL	CONDITION	MIN.	TYP.	MAX.	UNIT	Remarks	
Contrast (CEN)	CR	$\theta = \psi = 0^\circ$ Point-5	900	1200		--	*1)*2)*3)	
Luminance	Central luminance	$\theta = \psi = 0^\circ$	$\theta = \psi = 0^\circ$	300	400		cd/m ²	*6)
	5P Luminance (AVG)	$\theta = \psi = 0^\circ$	$\theta = \psi = 0^\circ$		350		cd/m ²	*2)*3)
Response Time (Gray to gray average)		trg , tfg	$\theta = \psi = 0^\circ$		8	15	ms	*4)
View angle	Horizontal	ψ	CR 20 Point-5	-80~80	-88~88	--	°	*2)*3)
	Vertical	θ		-80~80	-88~88	--	°	*2)*3)
Color Temperature Coordinate	Red	Rx Ry	$\theta = \psi = 0^\circ$ Point-5	0.620 0.303	0.650 0.333	0.680 0.363	--	*2)*3)
	Green	Gx Gy		0.247 0.578	0.277 0.608	0.307 0.638		
	Blue	Bx By		0.115 0.047	0.145 0.077	0.175 0.107		
	White	Wx Wy		0.250 0.260	0.280 0.290	0.310 0.320		
Color Gamut		CG			75		%	*5)

[Note]

These items are measured using: BM-5A (TOPCON)

[under the dark room condition (no ambient light)]

Definition of these measurement items is as follows:

*1) Definition of Contrast Ratio:

$$CR = \text{ON (White) Luminance} / \text{OFF (Black) Luminance}$$

*2) Definition of Luminance, Luminance uniformity, Contrast, and the Deviation of Color Coordinate:

Luminance and Contrast: To measure at the center position "5" on the screen (NO.5), see Figure.8-1 below.

Luminance uniformity: Lw (MAX) and Lw(MIN) are the maximum and minimum luminance value measure at the position "1~5" on the screen (NO.1~5), see Figure.8-1 and below show equation:

$$\Delta Lw = [Lw(\text{MIN}) / Lw(\text{MAX})] \times 100\%$$

The Deviation of Color Coordinate: To measure at the position "1~5" on the screen (NO.1~5), see Figure.8-1 below.

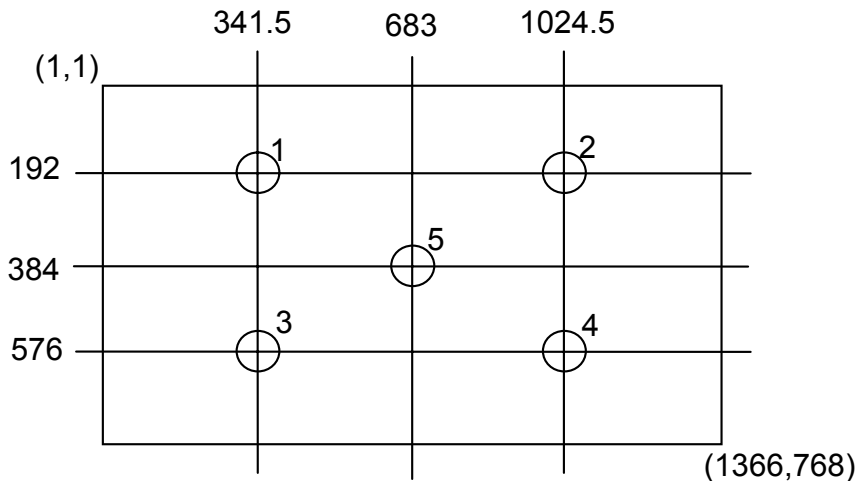

Figure 8-1. Measurement Positions

*3) Definition of Viewing Angle (θ , ϕ):

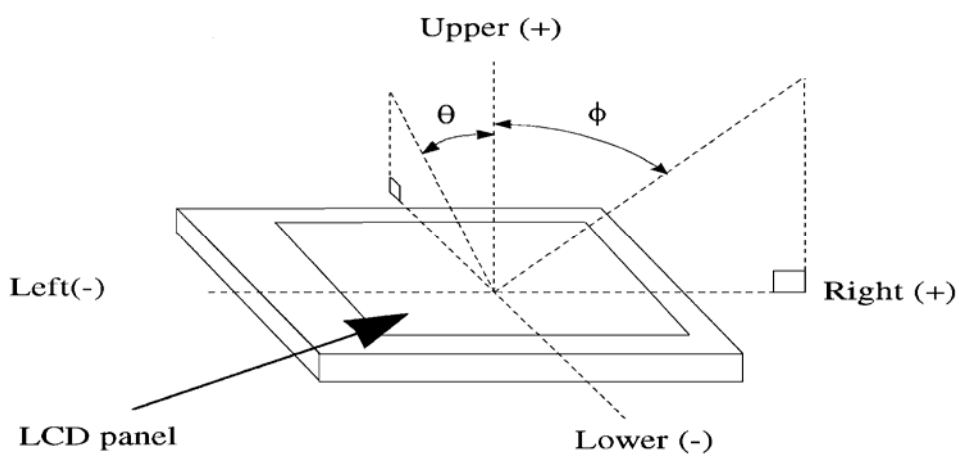

Figure 8-2. Definition of Viewing Angle

*4) Definition of Response Time (Gray to Gray, Average)

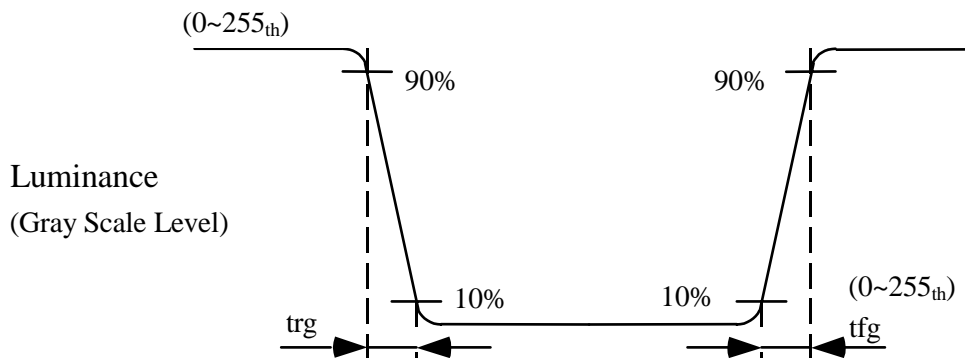

Figure 8-4. Definition of Response Time (Gray to Gray)

The driving signal time means the signal of gray level 0, 31, 63, 95, 127, 159, 191, 223, 255. Gray to gray average means the average switching time of gray level 0, 31, 63, 95, 127, 159, 191, 223, 255 to each other.

The LCD module should be stabilized at given temperature for 30 mins to avoid abrupt temperature change during measuring. In order to stabilize the luminance, the measurement should be executed after lighting Backlight for 30 mins in a windless room.

*5) Definition of Color Gamut:

To measure RGB three sub-pixels color gamut coordinate at CIE coordinate chart from the center of module, to form a triangle area = A_{RGB} .

RGB three sub-pixels of NTSC at CIE coordinate chart to form a triangle area = N_{RGB} .

$$CG = \frac{A_{RGB}}{N_{RGB}} \times 100$$

*6) Definition of Central Luminance:

After lighting on the panel 30 mins, you can proceed the Central Luminance testing. The definition of Typ value is under status of Inverter Dimming Voltage=3.3V.

9. RELIABILITY TEST CONDITIONS

9.1 ENVIRONMENT TEST CONDITION

TEST ITEMS	CONDITIONS
High Temperature Operation	50 ; 240hrs
High Temperature Storage	60 ; 240hrs
High Temperature High Humidity Operation	50 ; 90% RH; 240 hrs (No condensation)
Low Temperature Operation	0 ; 240 hrs
Low Temperature Storage	-20 ; 240 hrs

9.2 SHOCK & VIBRATION TEST CONDITION

ITEMS	CONDITIONS
Shock (Non-Operation)	Shock level: 980m/s ² (100G) Waveform: half sinusoidal wave, 2ms Number of shocks: one shock input in each direction of three mutually perpendicular axes for a total of six shock inputs.
Vibration (Non-Operation)	Vibration level: 9.8m/s ² (1.0G) zero to peak Waveform: sinusoidal Frequency range: 10 to 300 Hz Frequency sweep rate : 0.5 octave/min Duration: each x, y, z axis:10 min, total 30 mins

9.3 JUDGMENT STANDARD

The judgment of the above test should be made as follow:

Pass: Normal display image with no obvious non-uniformity and no line defect.

Partial transformation of the module parts shall be ignored.

Fail: No display, obvious non-uniformity, or line defects.

10. HANDLING PRECAUTIONS FOR TFT-LCD MODULE

Please pay attention to the followings in handling TFT-LCD products.

10.1 ASSEMBLY PRECAUTION

- (1) Please use the mounting hole on the module side in installing and do not beading or wrenching LCD in assembling. And please do not drop, bend or twist LCD module in handling.
- (2) Please design display housing in accordance with the following guidelines.
 - Housing case must be destined carefully and do not to put stresses on LCD all sides or wrench module. The stresses may cause non-uniformity even if there is no non-uniformity statically.
 - Keep sufficient clearance between LCD module back surface and housing when the LCD module is mounted. Approximately 1.0 mm of the clearance in the design is recommended taking into account the tolerance of LCD module thickness and mounting structure height on the housing.
 - When some parts, such as, FPC cable and ferrite plate, are installed underneath the LCD module, still sufficient clearance is required, such as 0.5mm. This clearance is, especially, to be reconsidered when the additional parts are implemented for EMI countermeasure.
 - Design the inverter location and connector position carefully so as not to put stress on lamp cable.
 - Keep sufficient clearance between LCD module and the other parts, such as inverter and speaker so as not to interface the LCD module. Approximately 1.0mm of the clearance in the design is recommended.
- (3) Please do not push or scratch LCD panel surface with any-thing hard. And do not soil LCD panel surface by touching with bare hands. (Polarizer film and surface of LCD panel are easy to be flawed.)
- (4) Please do not press any parts on the rear side such as source TCP, gate TCP, control circuit board and FPC during handling the LCD module. If pressing rear part could not be avoided, handle the LCD module with care not to damage them.
- (5) Please wipe out LCD panel surface with absorbent cotton or soft clothe in case of it being soiled.
- (6) Please wipe out drops of adhesives like saliva and water on LCD panel surface immediately. They might damage to cause panel surface variation and color change.
- (7) Please do not take a LCD module to pieces and reconstruct it. Resolving and reconstructing modules may cause them not to work well.
- (8) Please do not touch metal frames with bare hands and soiled gloves. A color change of the metal frames can happen during a long preservation of soiled LCD modules.

- (9) Please pay attention to handling lead wire of backlight so that it is not tugged in connecting with inverter.

10.2 OPERATING PRECAUTIONS

- (1) Please be sure to turn off the power supply before connecting and disconnecting signal input cable.
- (2) Please do not change variable resistance settings in LCD module. They are adjusted to the most suitable value. If they are changed, it might happen LCD does not satisfy the characteristics specification.
 - (2-1) Please consider that LCD backlight takes longer time to become stable of radiation characteristics in low temperature than in room temperature.
 - (2-2) A condensation might happen on the surface and inside of LCD module in case of sudden change of ambient temperature.
 - (2-3) Please pay attention to displaying the same pattern for a very long time. Image might stick on LCD. If then, time going on can make LCD work well.
 - (2-4) Please obey the same caution descriptions as ones that need to pay attention to ordinary electronic parts.

10.3 PRECAUTIONS WITH ELECTROSTATICS

- (1) This LCD module use CMOS-IC on circuit board and TFT-LCD panel, and so it is easy to be affected by electrostatics. Please be careful with electrostatics by the way of your body connecting to the ground and so on.
- (2) Please remove protection film very slowly on the surface of LCD module to prevent from electrostatics occurrence.

10.4 STORAGE PRECAUTIONS

- (1) When you store LCD for a long time, it is recommended to keep the temperature between 0 ~40 without the exposure of sunlight and keep the humidity less than 90%RH.
- (2) Please do not leave the LCD in the environment of high humidity and high temperature such as 60 ~ 90%RH.
- (3) Please do not leave the LCD in the environment of low temperature(can not lower than -20).

10.5 SAFETY PRECAUTIONS

- (1) When you waste LCD, it is recommended to crush damaged or unnecessary LCD into pieces and wash them off with solvents such as acetone and ethanol, which should later be burned.
- (2) If any liquid leaks out of a damaged-glass cell and comes in contact with the hands, wash off thoroughly with soap and water.

10.6 OTHERS

- (1) A strong incident light into LCD panel might cause display characteristics' changing inferior because of polarizer film, color filter, and other materials becoming inferior. Please do not expose LCD module direct sunlight and strong UV rays.
- (2) Please pay attention on the side of LCD module do not contact with other materials in preserving it alone.
- (3) For the packaging box, please pay attention to the followings:
 - Packaging box and inner case for LCD are designed to protect the LCD from the damage or scratching during transportation. Please do not open except picking LCD up from the box.
 - Please do not pile them up more than 3 boxes. (They are not designed so.) And please do not turn over.
 - Please handle packaging box with care not to give them sudden shock and vibrations. And also please do not throw them up.
 - Packing box and inner case for LCD are made of cardboard. So please pay attention not to get them wet. (Such as keep them away the high humidity or wet place.)