



# Chunghwa Picture Tubes, Ltd.

## Product Specification

To :

Date : 100118

**TFT LCD**

**CLAB070JC01CW**

ACCEPTED BY : (V0.2)

APPROVED BY	CHECKED BY	PREPARED BY
張聖暉	李家銘	劉紀平

Prepared by :

Product Planning Management Division  
Small & Medium TFT Product Business Unit

**CHUNGHWA PICTURE TUBES, LTD.**

1127 Hopin Rd., Padeh, Taoyuan, Taiwan 334, R.O.C.

Doc.No:

Issue Date:

# REVISION STATUS

Revision Notice	Description	Page	Rev. Date
0.0	First revision (Tentative)	--	2009/11/05
0.1	Revise Power sequence	7	2009/11/24
0.1	Revise Timing characteristics of input signals	8~9	2009/11/24
0.1	Revise CN1(Note1)	10~11	2009/11/24
0.2	Revise Vcom	6	2010/01/15
0.2	Revise reliability test	16	2010/01/15

## CONTENTS

<b>1. OVERVIEW .....</b>	<b>4</b>
<b>2. ABSOLUTE MAXIMUM RATINGS .....</b>	<b>5</b>
<b>3. ELECTRICAL CHARACTERISTICS.....</b>	<b>6</b>
3.1 Typical operation conditions .....	6
3.2 Current consumption.....	7
3.3 Power 、 Signal sequence .....	7
3.4 Timing characteristics of input signals .....	8
<b>4. INTERFACE CONNECTION: .....</b>	<b>10</b>
4.1 CN1(Signal of interface) .....	10
<b>5. MECHANICAL DIMENSION .....</b>	<b>12</b>
<b>6. OPTICAL CHARACTERISTICS.....</b>	<b>14</b>
<b>7. RELIABILITY TEST .....</b>	<b>16</b>

## 1. OVERVIEW

**CLAB070JC01CW** is 7.0" color TFT-LCD (Thin Film Transistor Liquid Crystal Display) OLB module (finish outer lead bonding) composed of LCD panel and driver ICs (the backlight is not included in this OLB module).

The 7.0" (17.67cm) screen produces 480(\*3)X234 WQVGA resolution image. By applying R.G.B. input signal, full color images are displayed.

General specifications are summarized in the following table:

ITEM	SPECIFICATION
Display Area (mm)	154.08 (H) × 86.58 (V)
Number of Pixels	480(H) × 3(RGB) × 234(V)
Pixel Pitch (mm)	0.107(H) × 3(RGB) × 0.37(V)
Color Pixel Arrangement	RGB vertical stripe
Display Mode	Normally white, TN
Number of color	Full color
Viewing Direction	6 o'clock
Response Time (Tr+Tf)	20ms (typ.)
Panel Transmittance (%)	8.5 (typ.)
Power Consumption(W)	0.042W (typ)
Surface Treatment	Anti-Glare, Hardness:3H

## 2. ABSOLUTE MAXIMUM RATINGS

ITEM	SYMBOL	conditions	MIN.	MAX.	UNIT	NOTE
Power Supply Voltage for LCD	VCC	GND=0	-0.3	6	V	
	AVDD	AVSS=0	-0.3	7	V	
	VGH	GND=0	-0.3	32	V	
	VGL		-22	0.3	V	
	VGH-VGL	GND=0	-0.3	40	V	
Signal input voltage	Vi		-0.2	AVDD+0.2	V	Note1
Operating temperature	Topa		-20	70	°C	Note3
Storage temperature	Tstg		-30	80	°C	Note3

Note1 : Analog input voltage VR, VG, VB

Note2 : Logical signal STHL, STHR, OEH, L/R, CPH1~CPH3, STVR, STVL, OEV,CKV, U/D.

Note3 : If users use the product out off the environmental operation range ( temperature and humidity ) , it will have visual quality concerns.

### 3. ELECTRICAL CHARACTERISTICS

#### 3.1 Typical operation conditions

GND = Avss = 0V (Ta=25°C )

ITEM	SYMBOL	MIN.	TYP.	MAX.	UNIT	NOTE
Power Supply Voltage	VCC	3.0	3.3	3.6	V	Note5
		4.5	5	5.5	V	
	AVDD	4.5	5	5.5	V	
	VGH	17	18	19	V	
Signal Amplitude (VR, VG, VB)	VGL	-7	-6	-5	V	
	V <sub>iA</sub>	0.4	-	AVDD-0.4	V	Note1
	V <sub>iAC</sub>	-	4	-	V	Note1
	V <sub>iDC</sub>	-	AVDD/2	-	V	Note1
VCOM	V <sub>CAC</sub>	4	4.7	5.4	V <sub>P-P</sub>	Note1,2
	V <sub>CDC</sub>	1.7	1.8	1.9	V	Note1,3
Input Signal Voltage	V <sub>IH</sub>	0.7VCC	-	VCC	V	Note4
	V <sub>IL</sub>	GND	-	0.3VCC	V	

Note1 : Please refer to Fig.1 VCOM-RGB diagram

Note2 : Brightness level is adjusted by varying this amplitude V<sub>CAC</sub>

Note3 : Please adjust V<sub>CDC</sub> to make the flicker level be minimum.

Note4 : Logical signal STHL,STHR,OEH,L/R,CPH1~CPH3,STVR,STVL,OEV,CKV,U/D.

Note5 : Vcc please refer T-con setup on system

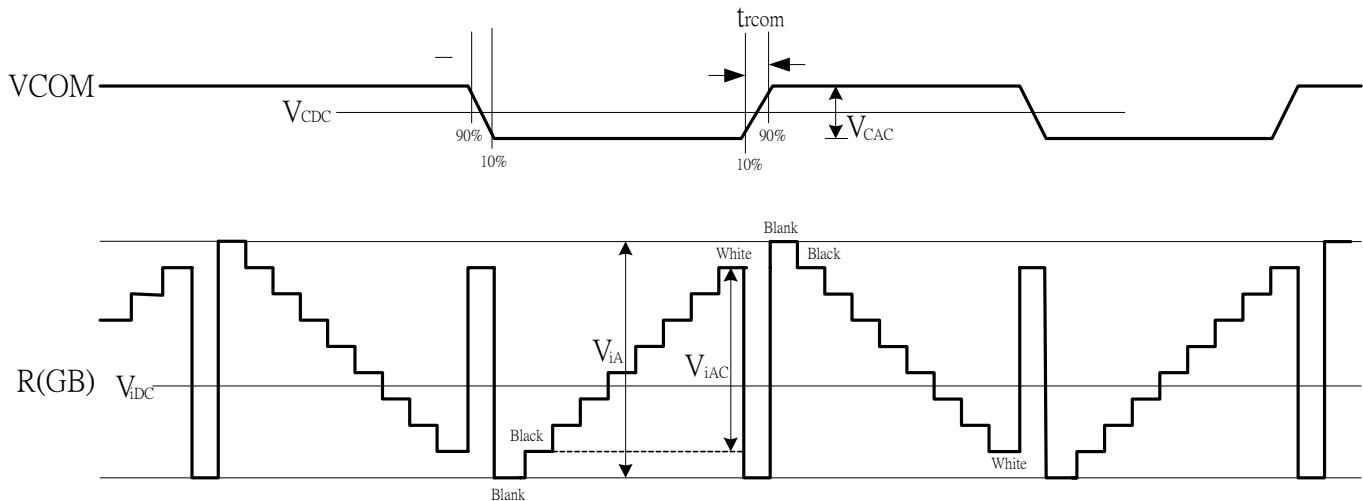

Fig.1 VCOM-RGB

### 3.2 Current consumption

(GND = Avss = 0V)

ITEM	SYMBOL	conditions	MIN.	TYP.	MAX.	UNIT	NOTE
Drive Current	$I_{GH}$	$V_{GH} = 18V$	-	0.12	1	mA	Note1
	$I_{GL}$	$V_{GL} = -6V$	-	0.45	1	mA	Note1
	$I_{CC}$	$V_{CC} = 5V$	-	2.5	4.5	mA	Note1
	$I_{DD}$	$AV_{DD} = 5V$	-	5	10	mA	Note1

[Note1] : Typ. specification : Gray-level test Pattern  
 Max. specification : Black test Pattern

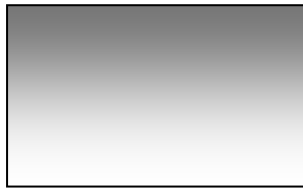

(a) Gray-level Pattern

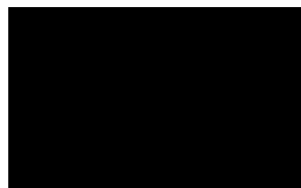

(b) Black Pattern

### 3.3 Power & Signal sequence

Power On :  $V_{CC} \rightarrow AV_{DD}/V_{GL} \rightarrow V_{GH}$  Video & Logic Signal  
 Power Off : Video & Logic Signal  $\rightarrow V_{GH}$  VCC

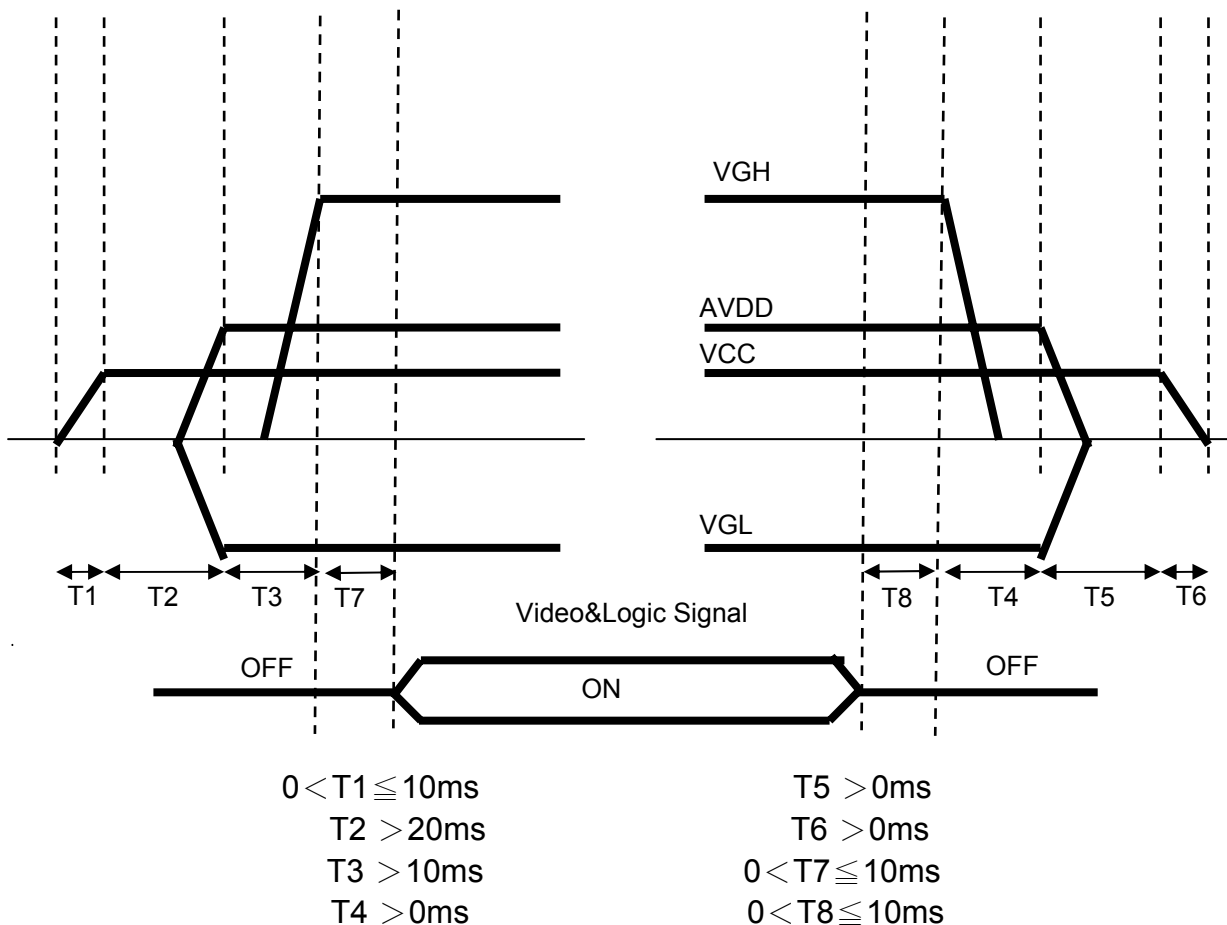

Fig.2 Power sequence

## 3.4 Timing characteristics of input signals

CHARACTERISTICS	SYMBOL	MIN.	TYP.	MAX.	UNIT	NOTE
Source driver operating frequency	$1/T_{CW}$	-	9.4	-	MHz	
CPH pulse width	$T_{CW}$	100	106	108	ns	CPH1~CPH3
CPH pulse high period	$T_{CWH}$	40	49	60	ns	CPH1~CPH3
CPH pulse low period	$T_{CWL}$	40	49	60	ns	CPH1~CPH3
CPH pulse delay	TC12 TC23 TC31	32.5	35.2	38.2	ns	CPH1~CPH3
STH start pulse width	$T_{STH}$	30	92.8	-	ns	STHR,STHL
STH start pulse setup time	$T_{SUH}$	20	56	-	ns	STHR,STHL
STH start pulse hold time	$T_{HDH}$	10	35	-	ns	STHR,STHL
OEH output enable pulse width	$T_{OEH}$	1.5	2.3	2.5	$\mu$ s	OEH
Sample and hold disable time OEH& STH	$T_{OEH-STH}$	-	8.6	-	$\mu$ s	OEH-STH
CKV pulse width	$T_{CKVW}$	5	64	-	$\mu$ s	CKV
CKV pulse high period	$T_{CKVH}$	2.5	11.2	-	$\mu$ s	CKV
CKV pulse low period	$T_{CKVL}$	2.5	53.2	-	$\mu$ s	CKV
STV start pulse width	$T_{STV}$	5	64	-	$\mu$ s	STVR, STVL
STV start pulse setup time	$T_{SUV}$	2.5	52.8	-	$\mu$ s	STVR, STVL
STV start pulse hold time	$T_{HDV}$	2.5	11.2	-	$\mu$ s	STVR,STVL
OEV pulse width	$T_{OEV}$	1	5.18	-	$\mu$ s	OEV
OEV setup time	$T_{OEVSU}$	0.5	-	-	$\mu$ s	OEV
OEV hold time	$T_{OEVHD}$	0.5	-	-	$\mu$ s	OEV

Note1 : 1. High level of source driver and gate driver logic signal are 70%  
2. Low level of source driver and gate driver logic signal are 30%

Note2 : Please refer to Fig.3 and Fig.4

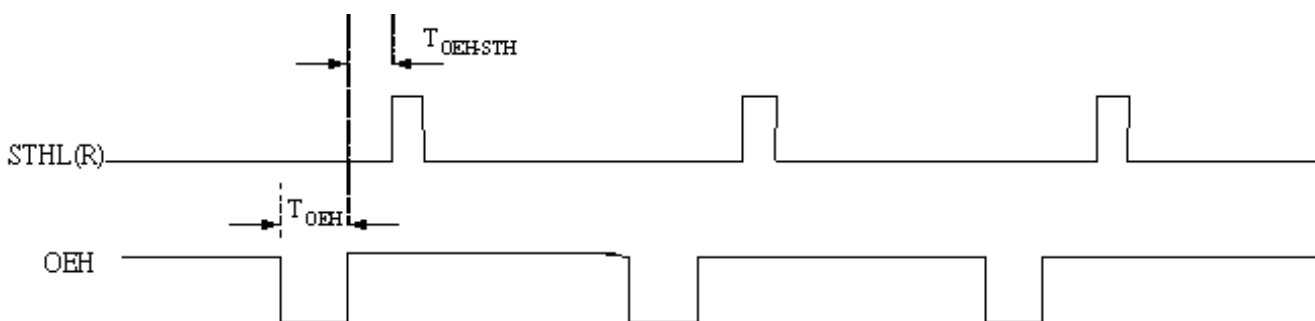



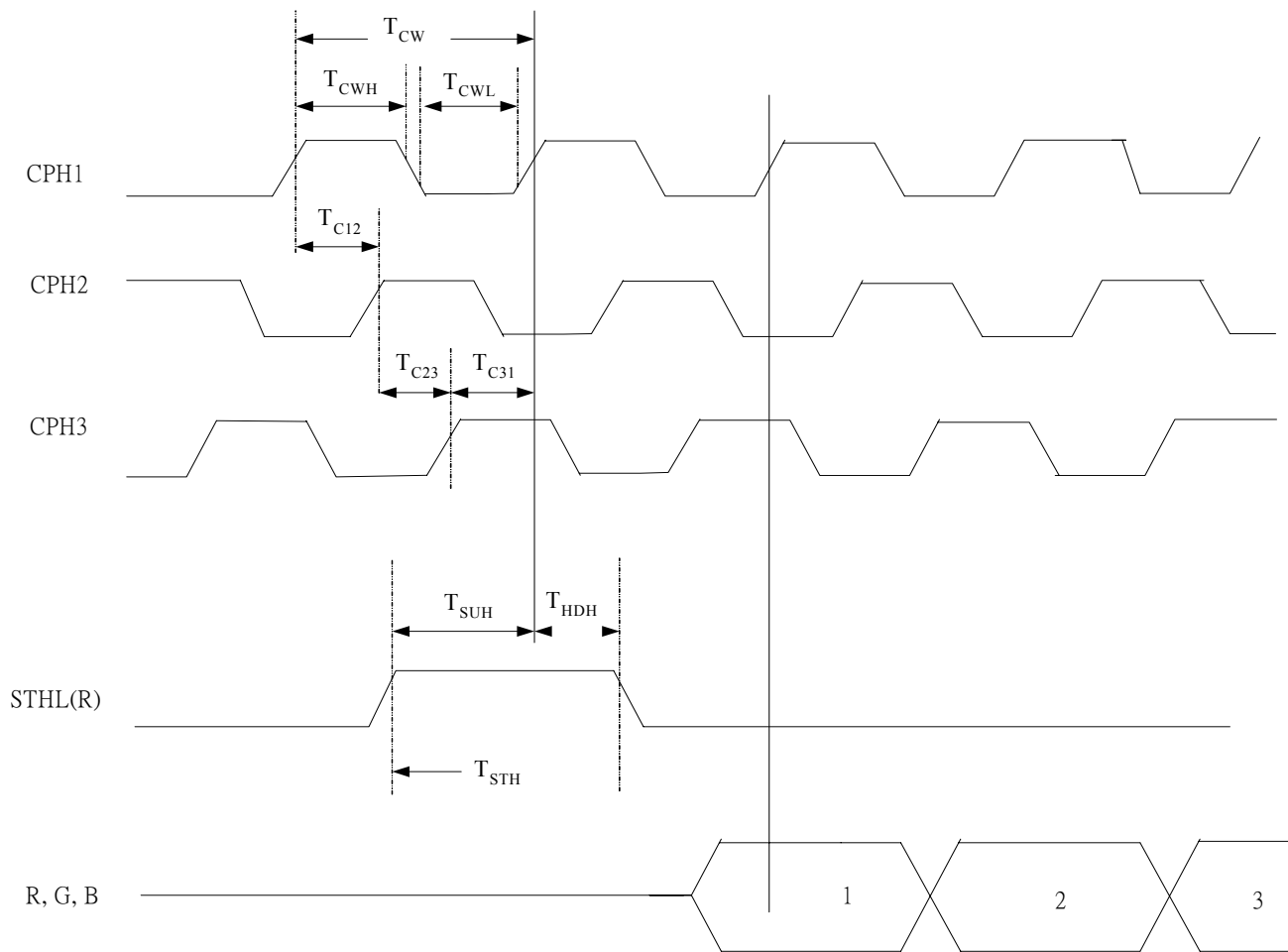

Fig.3 Horizontal Timing

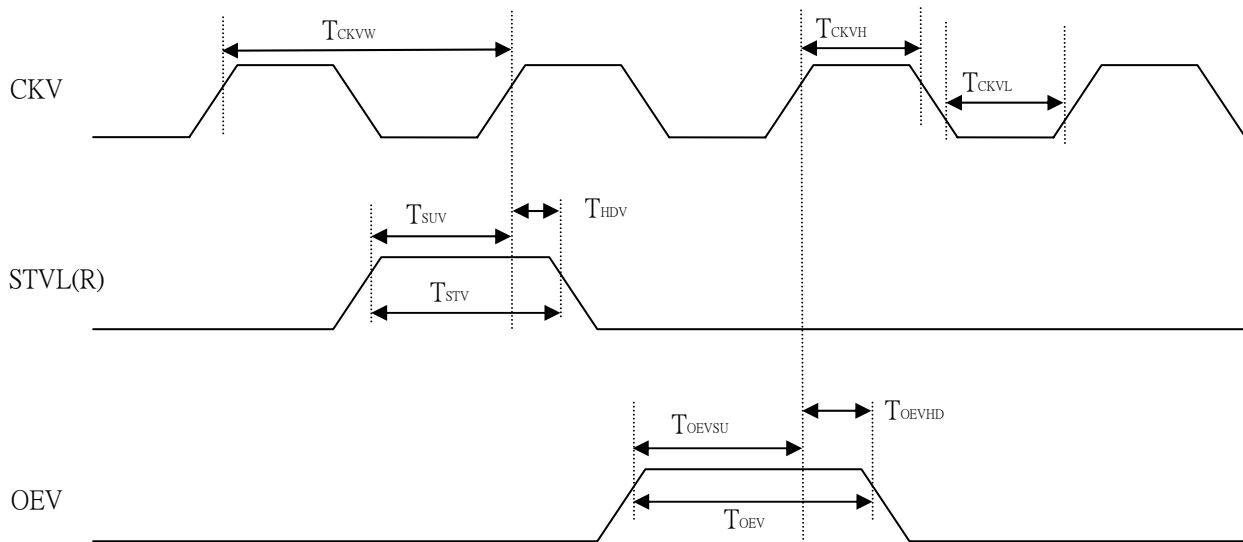

Fig.4 Vertical Timing sequence

## 4. INTERFACE CONNECTION:

### 4.1 CN1(Signal of interface)

Pin No.	SYMBOL	I/O	FUNCTION	NOTE
1	GND	-	Ground for logic circuit	
2	VCC		Supply voltage of logic control circuit for scan driver	
3	VGL		Negative power for scan driver	
4	VGH		Positive power for scan driver	
5	STVR	I/O	Vertical start pulse	Note 1
6	STVL	I/O	Vertical start pulse	Note 1
7	CKV		Shift clock input for scan driver	
8	U/D		UP/DOWN scan control input	Note 1
9	OEV		Output enable input for driver	
10	VCOM		Common electrode driving signal	
11	VCOM		Common electrode driving signal	
12	L/R		LEFT/RIGHT scan control input	Note 1
13	MOD		Sequential sampling and simultaneous sampling setting	Note 2
14	OEH		Output enable input for data driver	
15	STHL	I/O	Start pulse for horizontal scan line	Note 1
16	STHR	I/O	Start pulse for horizontal scan line	Note 1
17	CPH3		Sampling and shifting clock pulse3 for data drive	
18	CPH2		Sampling and shifting clock pulse2for data drive	
19	CPH1		Sampling and shifting clock pulse1 for data drive	
20	VCC		Supply voltage of logic control circuit for data driver	
21	GND	-	Ground for logic circuit	
22	VR		Alternated video signal input(Red)	
23	VG		Alternated video signal input(Green)	
24	VB		Alternated video signal input(Blue)	
25	AVDD		Supply voltage for analog circuit	
26	AVSS	-	Ground for analog circuit	

Note1 :

The function of STVR and STVL is changed as follows by the U/D terminal (up/down scanning)

U/D	STVR	STVL
H(VCC)	Signal Input	Signal Output
L(GND)	Signal Output	Signal Input

The function of STHL and STHR is changed as follows by the L/R terminal (right/left scanning)

L/R	STHL	STHR
H(VCC)	Signal Input	Signal Output
L(GND)	Signal Output	Signal Input

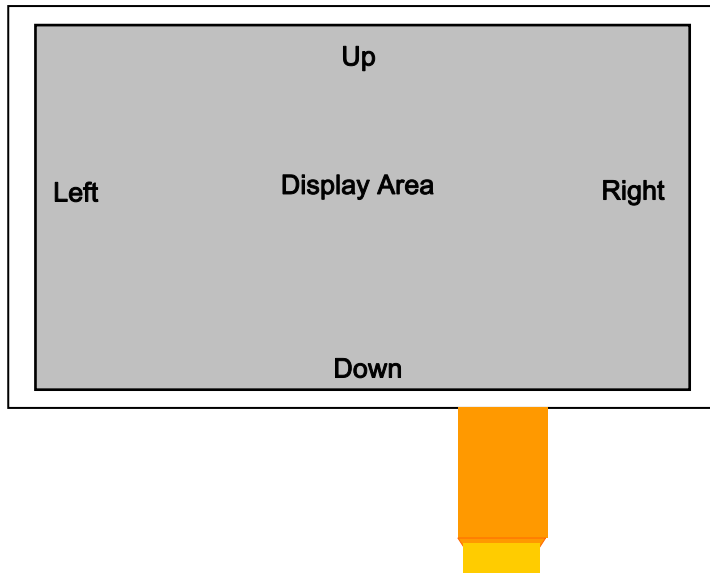

Setting of scan control input		IN/OUT state for start pulse				Scanning direction
U/D	L/R	STVR	STVL	STHR	STHL	
GND	VCC	OUT	IN	OUT	IN	From Up to Down , From Left to Right
VCC	GND	IN	OUT	IN	OUT	From Down to Up , From Right to Left
GND	GND	OUT	IN	IN	OUT	From Up to Down , From Right to Left
VCC	VCC	IN	OUT	OUT	IN	From Down to Up , From Left to Right

Note2 : MOD=H: Simultaneous sampling (Set CPH2 and CPH3 to LOW)  
 MOD=L: Sequential sampling

### 5. MECHANICAL DIMENSION

#### (1) Front Side

(Unit : mm)

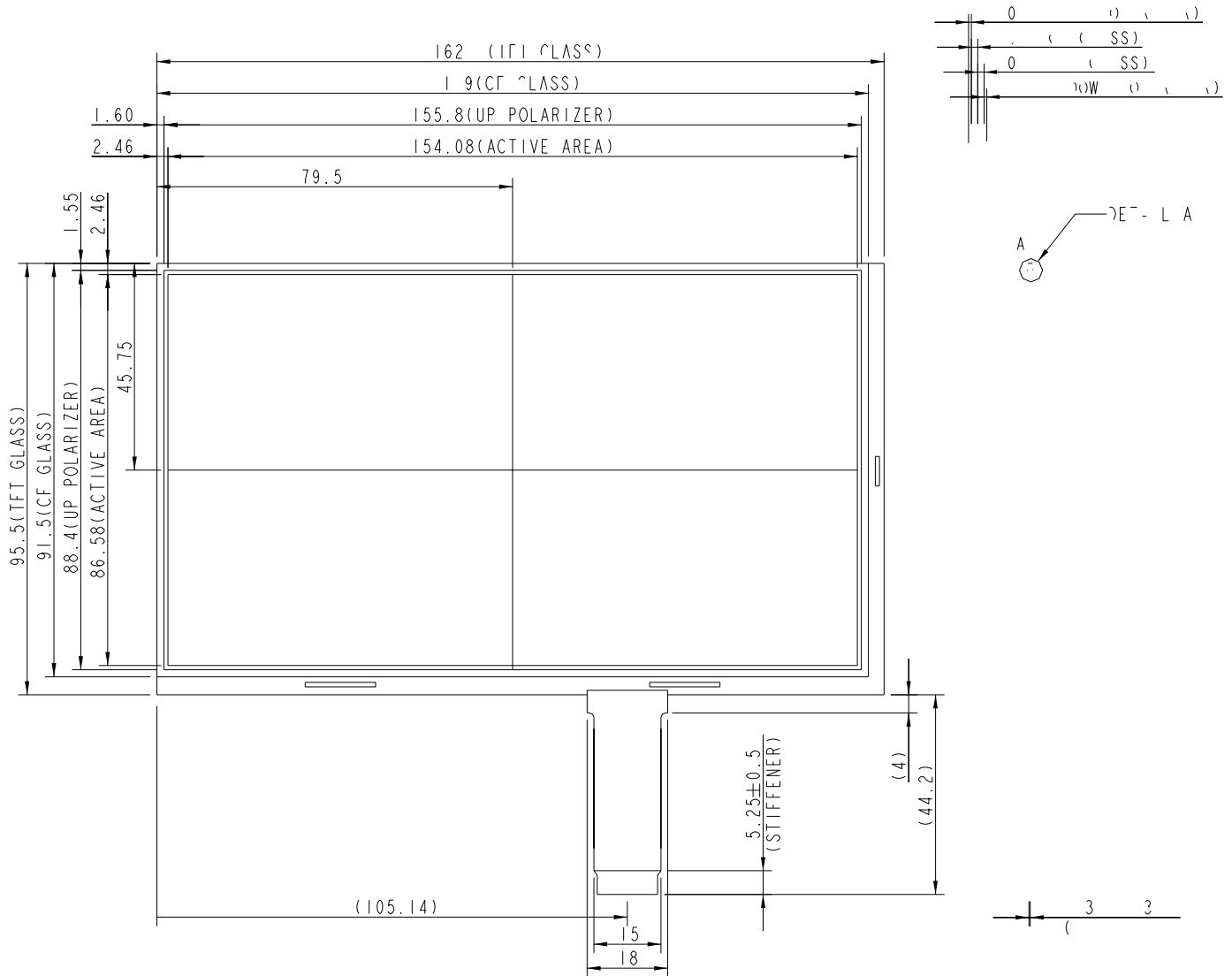

[Note] : Tolerance is  $\pm 0.3$ mm unless noted

(2) Rear Side

(Unit : mm)

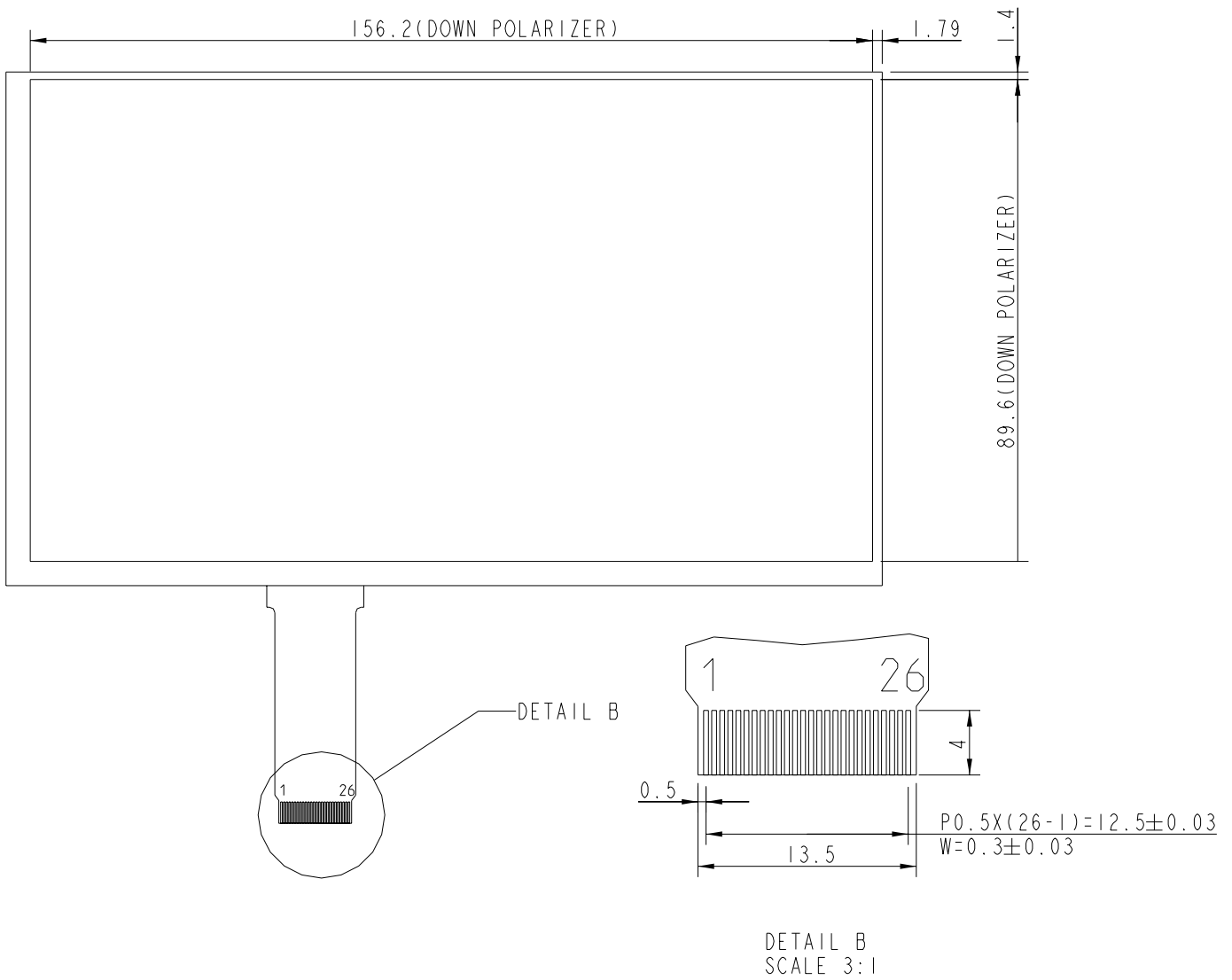

[Note] : Tolerance is  $\pm 0.3$ mm unless noted

### 6. OPTICAL CHARACTERISTICS

Ta=25°C

ITEM	SYMBOL	CONDITION	MIN.	TYP.	MAX.	UNIT	NOTE
Panel Transmittance	T	—	7.8	8.5	--	%	
Contrast Ratio	CR	Point-5 )	300	400	--	--	*1
Response Time	Tr +Tf	Point-5	--	20	30	ms	*3)
Viewing Angle	Horizontal	Point-5 CR ≥ 10	120	140	--	°	*2)
	Vertical		100	120	--	°	

[Note]

These items are measured by BM-5A (TOPCON) or CA-1000(MINOLTA) in the dark room. (no ambient light)

Measuring point : Fig.5 Measurin-point : 1~9 points

Measuring Viewing Angle : Fig.6 :  $\theta = \psi = 0^\circ$

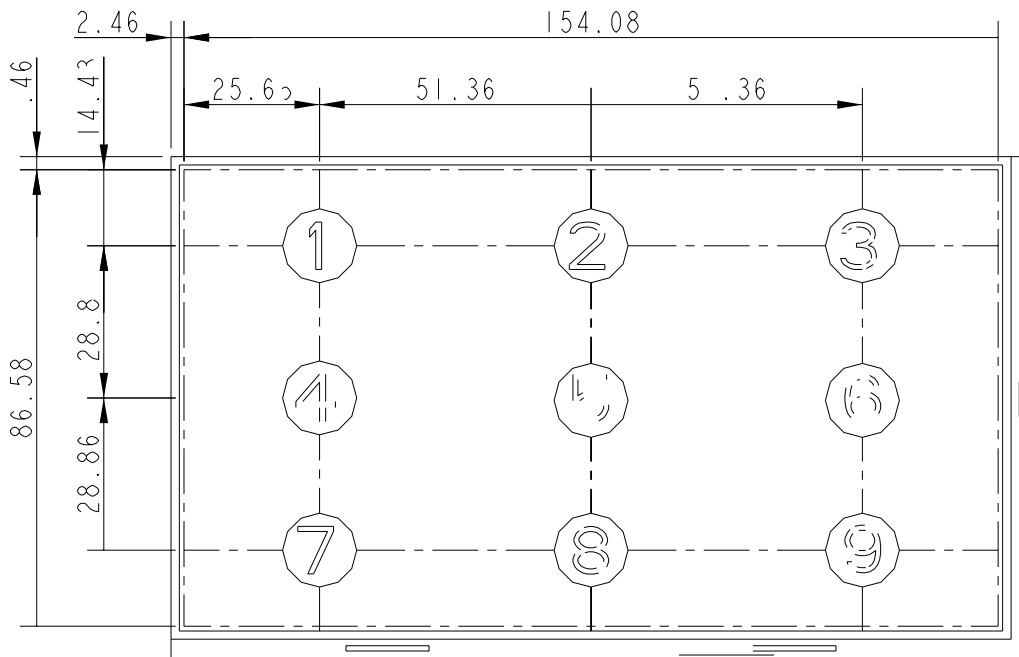

Fig.5 Measuring point

\*1) Definition of contrast ratio :

Measure contrast ratio on the Point-5 (refer to figure 5 ) Contrast ratio is calculated with the following formula :

$$\text{Contrast Ratio (CR)} = (\text{White}) \text{ Luminance of ON} \div (\text{Black}) \text{ Luminance of OFF}$$

\*2) Definition of Viewing Angle( $\theta, \psi$ ) :

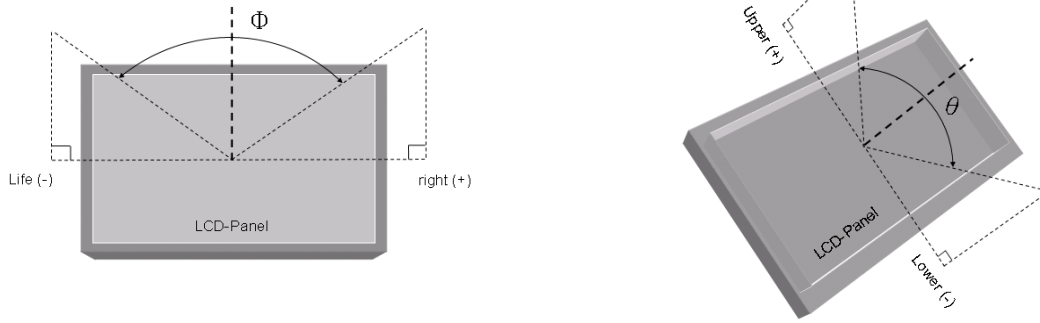

Fig.6 Definition of Viewing Angle

\*3) Definition of Response Time

The response time is defined as the time interval between the 10% and 90% amplitudes. Refer to figure 7 as below.

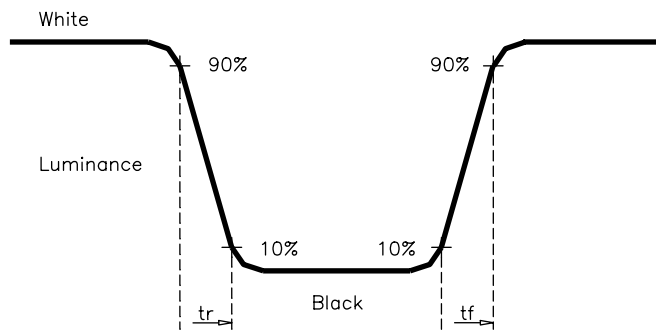

Fig.7 Definition of Response Time

## 7. RELIABILITY TEST

These tests are conducted with CPT backlight.

### 7.1 Temperature and Humidity

TEST ITEMS	CONDITIONS	NOTE
High Temperature Operation	70°C ; 240hrs	
High Temperature Storage	80°C ; 240hrs	
High Temperature High Humidity Operation	60°C ; 90%RH ; 240hrs (No condensation)	
Low Temperature Operation	-20°C ; 240hrs	
Low Temperature Storage	-30°C ; 240hrs	
Thermal Shock	-30°C (0.5hr) ~ 80°C (0.5hr) ; 200 Cycles	Non-Operating
Image Sticking	25°C ; 4hrs	Note (1)

[Note] :

(1) Condition of Image Sticking test : 25 ±

Operation with test pattern sustained for 4 hrs, then change to gray pattern immediately.

After 5 mins, the mura must be disappeared completely .

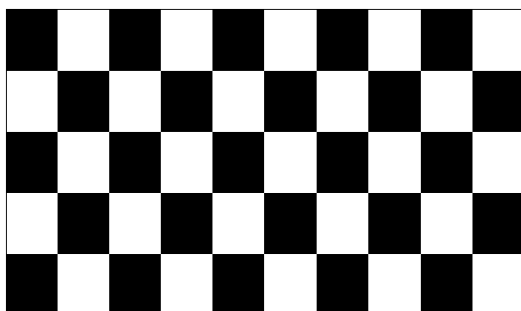

(a) Test Pattern (chess board Pattern )

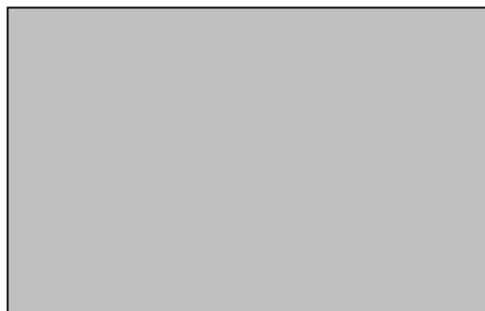

(b) Gray Pattern

### 7.2 Shock and Vibration

ITEMS	CONDITIONS
Shock (Non-Operation)	<ul style="list-style-type: none"> <li>● Shock level : 980m/s<sup>2</sup>(equal to 100G).</li> <li>● Waveform : 1/2 Sine wave,6msec</li> <li>● ±X , ±Y , ±Z , each axis 1 times</li> </ul>
Vibration (Non-Operation)	<ul style="list-style-type: none"> <li>● Frequency range : 8~33.3Hz</li> <li>● Stoke : 1.3 mm</li> <li>● Vibration : sinusoidal wave, perpendicular axis (both x, z axis:2Hrs, y axis 4Hrs).</li> <li>● Sweep : 2.9G, 33.3 Hz -400 Hz</li> <li>● Cycle : 15 min</li> </ul>



### 7.3 Electrostatic Discharge

TEST ITEM	CONDITIONS	Note
ESD	150pF , 330Ω , ±8kV&±15kV air& contact test	(1)
	200pF , 0Ω , ±200V contact test	(2)

[Note] : Measure point :

- (1) LCD glass and metal bezel
- (2) IF connector pins

### 7.4 Judgment Standard

The judgment of the above test should be made as follow:

Pass: Normal display image with no obvious non-uniformity and no line defect.

Partial transformation of the module parts should be ignored.

Fail: No display image, obvious non-uniformity, or line defects.