



# Chunghwa Picture Tubes, Ltd.

## Technical Specification

To : **SCL**  
Date : **2011/05/16**

**TFT LCD**  
**CLAB133WB01      1G1**

ACCEPTED BY :

APPROVED BY	CHECKED BY	PREPARED BY
Ronald Huang	Roger Liu	Carol Shen

Prepared by :

Product Planning Management Division  
VD Business Unit

**CHUNGHWA PICTURE TUBES, LTD.**

1127 Hopin Rd., Padeh, Taoyuan, Taiwan 334, R.O.C.  
TEL: +886-3-3675151 FAX: +886-3-377-3003

Doc.No:	CLAB133WB01    1G1-SCL-V1-20110516	Issue Date:	2011/05/16
---------	------------------------------------	-------------	------------





## 1. OVERVIEW

**CLAB133WB01 1G1** is 13.3" color (16 : 9) TFT-LCD (Thin Film Transistor Liquid Crystal Display) module composed of LCD panel, LVDS driver ICs, control circuit and backlight. By applying 6 bit digital data, 1366×RGB (3) ×768, 262K-color images are displayed on the 13.3" diagonal screen. General specifications are summarized in the following table :

ITEM	SPECIFICATION
Display Area	293.417(H)×164.966(V)(mm) (13.3-inch diagonal)
Number of Pixels	1366×3(H)×768(V)
Pixel Pitch	0.2148(H)×0.2148(V) (mm)
Color Pixel Arrangement	RGB island
Display Mode	Normally white
Number of Colors	262,144(6bits) (LVDS)
Surface Treatment	Glare ; Hardness: 3H
Viewing Angle	40°、40°/15°、30° (Min)

## 2. ABSOLUTE MAXIMUM RATINGS

The following are maximum value, which if exceeded, may cause faulty operation or damage to the unit.

ITEM	SYMBOL	MIN	MAX	UNIT	NOTE
LCD Power Voltage	VCC	0	4.0	V	
LED Driver Input Voltage	VBL+	7	21	V	
Operation Temperature	Top	0	50	°C	*1).*2).*3).*4)
Storage Temperature	Tstg	-25	65	°C	*1).*2).*3)

### 【Note】

- \*1) The relative temperature and humidity range are as below sketch, 90%RH Max. ( $T_a \leq 40^\circ\text{C}$ )
- \*2) The maximum wet bulb temperature  $\leq 39^\circ\text{C}$  ( $T_a > 40^\circ\text{C}$ ) and without dewing.
- \*3) If product in environment which over the definition of the relative temperature and humidity out of range too long, it will affect visual of LCD.
- \*4) If you operate LCD in normal temperature range, the center surface of panel should be under  $50^\circ\text{C}$ .

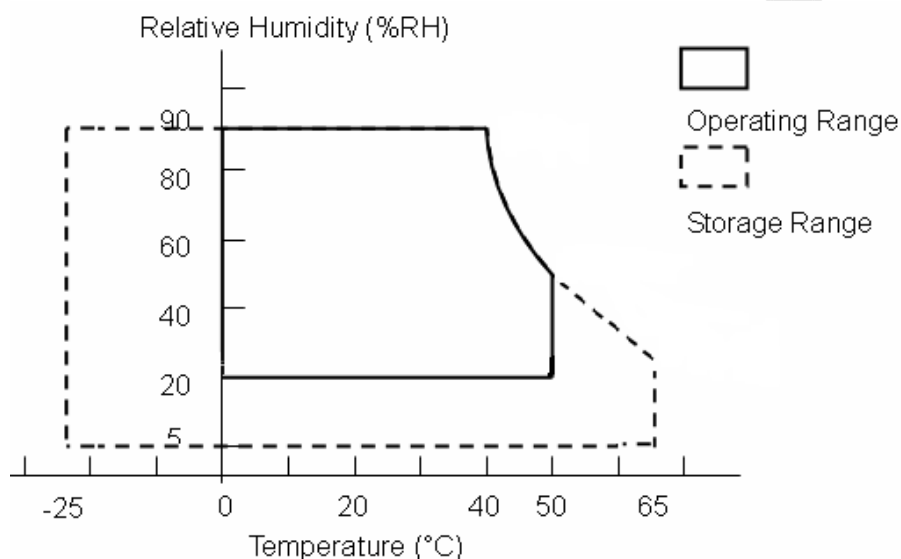

### 3. ELECTRICAL CHARACTERISTICS

#### (A) TFT LCD

ITEM	SYMBOL	MIN	TYP	MAX	UNIT	NOTE	
LCD Power Voltage	VCC	3.0	3.3	3.6	V	*1)	
LCD Power Current	ICC	-	260	340	mA	*2) Max = 2.2W	
Rush Current	Irush	-	-	2	A	*4)	
Logic Input Voltage (LVDS: IN+,IN-)	Common Voltage	VCM	1.125	1.25	1.375	V	*3)
	Differential Input Voltage	VID	250	350	450	mV	*3)
	Threshold Voltage (HIGH)	VTH	-	-	100	mV	*3) When VCM = +1.2V
	Threshold Voltage (LOW)	VTL	-100	-	-	mV	

#### 【Note】

\*1) Power Sequence :

$$0.50 \text{ ms} \leq t1 \leq 10 \text{ ms}$$

$$0.01 \text{ ms} < t2 \leq 50 \text{ ms}$$

$$0.01 \text{ ms} < t3 \leq 50 \text{ ms}$$

$$500 \text{ ms} \leq t4$$

$$200 \text{ ms} \leq t5$$

$$200 \text{ ms} \leq t6$$

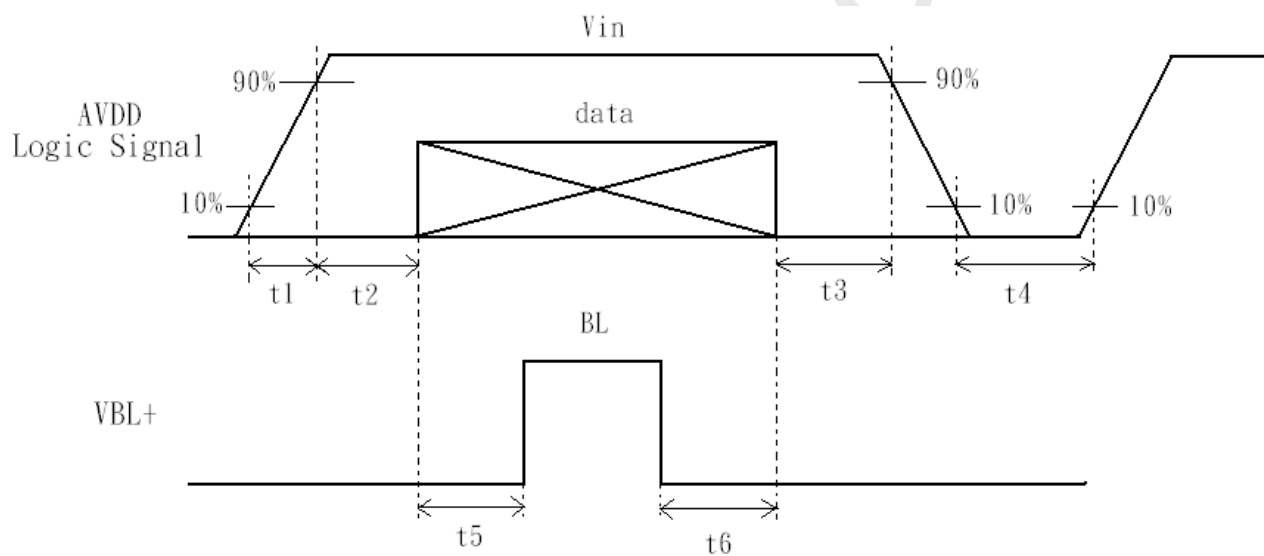

data: RGB DATA, DCLK, HD, VD, DENA

## VCC-dip state

(1) when  $3.0V > VCC \geq 2.7V$ ,  $t_d \leq 10$  ms.

(2) when  $VCC < 2.7V$ , VCC-dip condition should as the VCC-turn-off condition.

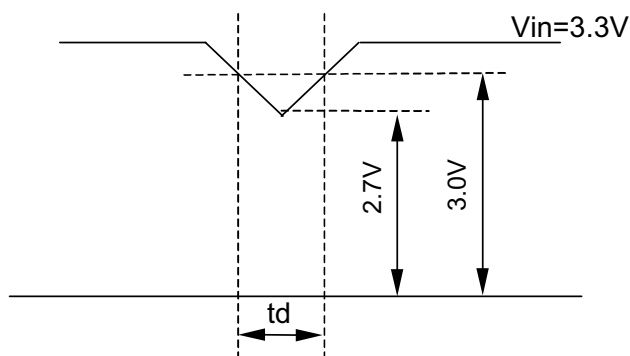

\*2) Typical value is Mosaic (32\*36 Checker board) Pattern : 768 line mode.

Circuit condition (Typ) :  $VCC=3.3$  V ,  $f_v=60$  Hz  $f_H=48.36$  kHz ,  $f_{CLK}=75.44$  MHz (one of LVDS dual port).

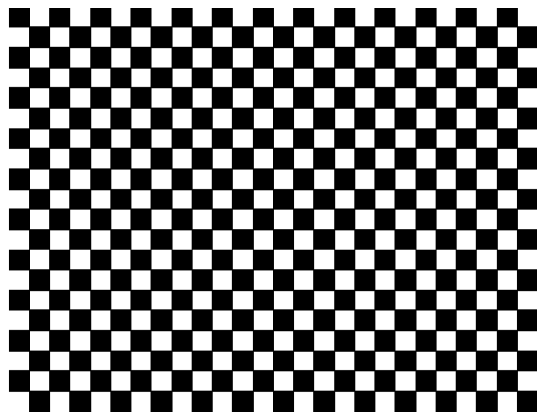

Max value is Black Pattern : 768 line mode.

Circuit condition (Max) :  $VCC=3.3$  V ,  $f_v=60$  Hz  $f_H=48.36$  kHz ,  $f_{CLK}=75.44$  MHz (one of LVDS dual port).

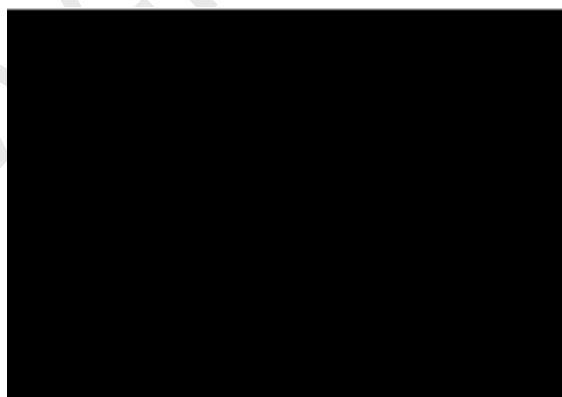





**(B) LED DRIVER****(a.) ELECTRICAL CHARACTERISTICS**

Ta=25°C

ITEM	SYMBOL	MIN	TYP	MAX	UNIT	NOTE
LED Driver Input Voltage	VBL+	7	12	21	V	
LED Driver Input Current	IBL+		190	380	mA	*1) Max = 2.66W
Forward Voltage	V <sub>F</sub>	2.9	3.2	3.5	V	*2) I <sub>F</sub> =16.5mA
Forward Current	I <sub>F</sub>	16	16.5	17	mA	*2)
PWM Frequency	PWM_BL	180	200	1k	Hz	*2)I <sub>F</sub> =16.5mA
Duty ratio	Dim	5		100	%	

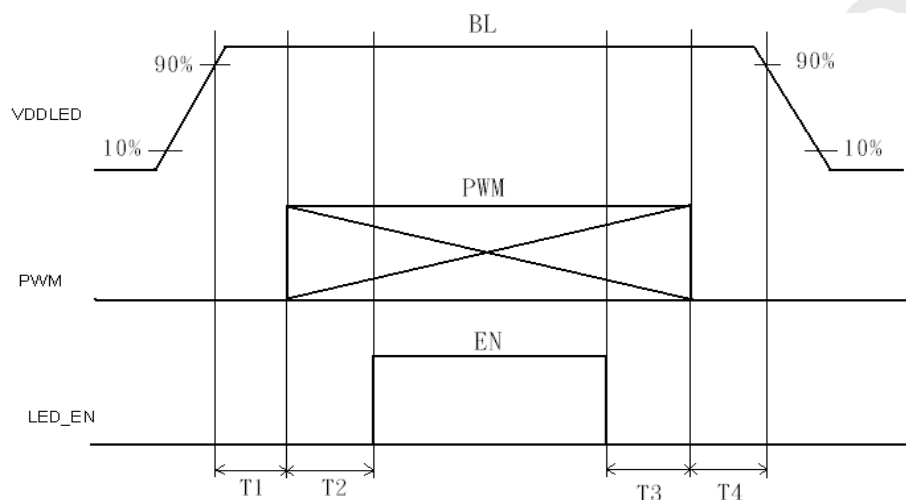
**(b.) LED ON/OFF Sequence :**

$$10\text{ms} \leq T1$$

$$0\text{ms} \leq T3$$

$$10\text{ms} \leq T2$$

$$10\text{ms} \leq T4$$

Note : The duty of LED dimming signal should be more than 20% in T2 and T3

\*1) Maximum LED Driver Input Current at 7V Input Voltage/PWM Duty 100%.

\*2) Measure method : a. LED current is measured by utilizing a current meter as show below.

b. System power P<sub>LED</sub> is measured at input voltage 12V.

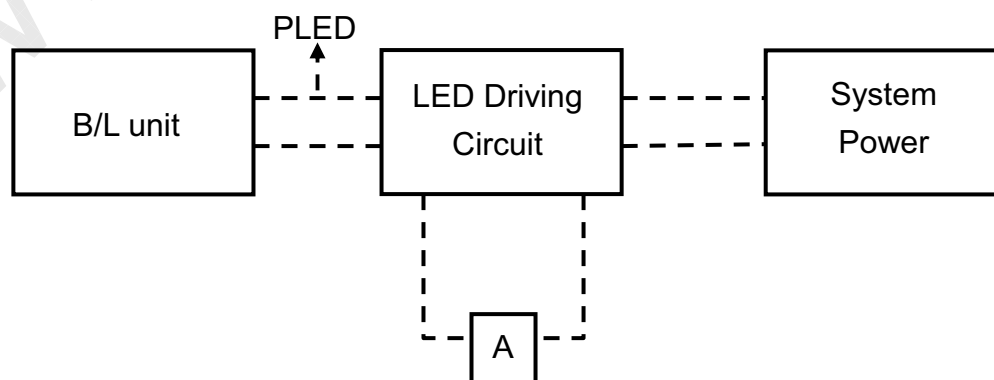

## 4. Connector Interface PIN & Function

### (a) CN1 (Interface signal)

Outlet connector: 20455-040E-02 (I-PEX) ; 5-2069716-3 (TYCO)

Pin No.	SYMBOL	FUNCTION
1	NC	No connection(Please let it floating for CPT test only)
2	VDD	Power Supply, 3.3 V (typical)
3	VDD	Power Supply, 3.3 V (typical)
4	V EEDID	DDC 3.3V power
5	NC	No connection(Please let it floating for CPT test only)
6	Clk EEDID	DDC Clock
7	DATA EEDID	DDC Data
8	Odd_Rin0-	- LVDS differential data input (R0-R5, G0) (odd pixels)
9	Odd_Rin0+	+ LVDS differential data input (R0-R5, G0) (odd pixels)
10	VSS	Ground – Shield
11	Odd_Rin1-	- LVDS differential data input (G1-G5, B0-B1) (odd pixels)
12	Odd_Rin1+	+ LVDS differential data input (G1-G5, B0-B1) (odd pixels)
13	VSS	Ground – Shield
14	Odd_Rin2-	- LVDS differential data input (B2-B5, HS, VS, DE) (odd pixels)
15	Odd_Rin2+	+ LVDS differential data input (B2-B5, HS, VS, DE) (odd pixels)
16	VSS	Ground – Shield
17	Odd_ClkIN-	- LVDS differential clock input (odd pixels)
18	Odd_ClkIN+	+ LVDS differential clock input (odd pixels)
19	NC	No connection(Please let it floating for CPT test only)
20	NC	No connection(Please let it floating for CPT test only)
21	NC	No connection(Please let it floating for CPT test only)
22	VSS	Ground – Shield
23	NC	No connection(Please let it floating for CPT test only)
24	NC	No connection(Please let it floating for CPT test only)
25	VSS	Ground – Shield
26	NC	No connection(Please let it floating for CPT test only)
27	NC	No connection(Please let it floating for CPT test only)
28	VSS	Ground – Shield
29	NC	No connection(Please let it floating for CPT test only)
30	NC	No connection(Please let it floating for CPT test only)
31	VSSLED	Ground – LED
32	VSSLED	Ground – LED
33	VSSLED	Ground – LED
34	NC	No connection(Please let it floating for CPT test only)
35	PWM	System PWM Signal Input (+3.3V Swing)
36	LED_EN	LED enable pin (+3.3V Input)
37	NC	No connection(Please let it floating for CPT test only)
38	VDDLED	7V – 21V LED power
39	VDDLED	7V – 21V LED power
40	VDDLED	7V – 21V LED power

**(2) CN2 (LED BACKLIGHT)**

Connector Part NO.: 196149-12041-3 (P2) or equivalent

	Pin	Signal	description
Pin assignment	1	VLED	LED power current supply
	2	VLED	LED power current supply
	3	VLED	LED power current supply
	4	NC	No connection
	5	NC	No connection
	6	NC	No connection
	7	NC	NC pin, no use
	8	NC	NC pin, no use
	9	LED1	LED stream1 current back in.
	10	LED2	LED stream2 current back in.
	11	LED3	LED stream3 current back in.
	12	LED4	LED stream4 current back in.

## 5. INTERFACE TIMING CHART

### (1)(a) LVDS input time sequence

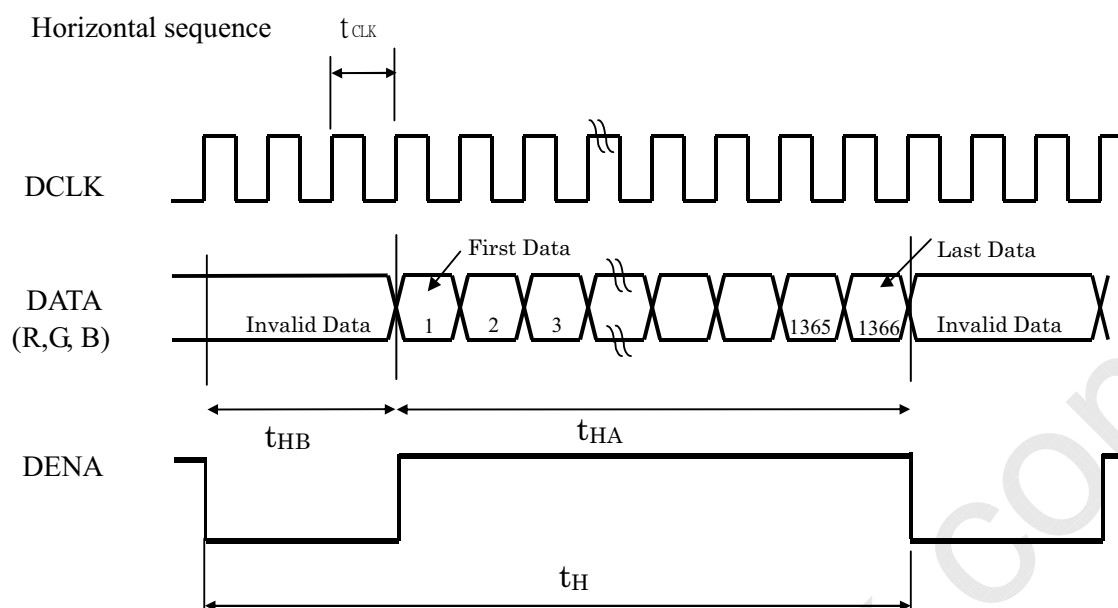

### (b) LCD input time sequence

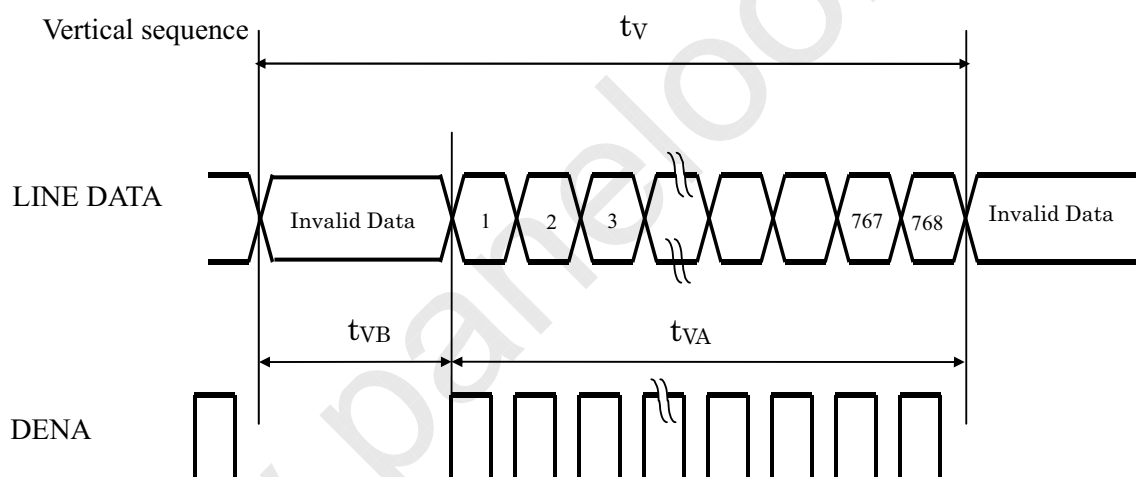

### (2) Timing Chart

ITEM		SYMBOL	MIN	TYP	MAX	UNIT		
LCD Timing	Frame Rate	-	55	60	60	Hz		
	DCLK	Frequency	$f_{CLK}$	63.17	75.44	88.74	MHz	
		Period	$t_{CLK}$	11.26	13.25	15.83	ns	
	DENA	Horizontal	Horizontal total time	$t_H$	1480	1560	1700	$t_{CLK}$
			Horizontal Active time	$t_{HA}$	1366	1366	1366	$t_{CLK}$
			Horizontal Blanking time	$t_{HB}$	114	194	334	$t_{CLK}$
	DENA	Vertical	Vertical total time	$t_V$	776	806	870	$t_H$
			Vertical Active time	$t_{VA}$	768	768	768	$t_H$
Vertical Blanking time			$t_{VB}$	8	38	102	$t_H$	
LVDS spread spectrum range *3)				-2	2	%		

## 【Note】

- \*1) DENA (DATA ENABLE) usually is positive.
- \*2) During the whole blank period, DCLK should keep input.
- \*3) LVDS input clock is 85MHz and modulation rate is fixed 100KHz.

## (3) DATA mapping

Color	Input Data	R DATA						G DATA						B DATA					
		R5	R4	R3	R2	R1	R0	G5	G4	G3	G2	G1	G0	B5	B4	B3	B2	B1	B0
		MSB					LSB	MSB					LSB	MSB					LSB
Basic Color	Black	0	0	0	0	0	0	0	0	0	0	0	0	0	0	0	0	0	0
	Red(63)	1	1	1	1	1	1	0	0	0	0	0	0	0	0	0	0	0	0
	Green(63)	0	0	0	0	0	0	1	1	1	1	1	1	0	0	0	0	0	0
	Blue(63)	0	0	0	0	0	0	0	0	0	0	0	0	1	1	1	1	1	1
	Cyan	0	0	0	0	0	0	1	1	1	1	1	1	1	1	1	1	1	1
	Magenta	1	1	1	1	1	1	0	0	0	0	0	0	1	1	1	1	1	1
	Yellow	1	1	1	1	1	1	1	1	1	1	1	1	0	0	0	0	0	0
	White	1	1	1	1	1	1	1	1	1	1	1	1	1	1	1	1	1	1
RED	RED(0)	0	0	0	0	0	0	0	0	0	0	0	0	0	0	0	0	0	0
	RED(1)	0	0	0	0	0	1	0	0	0	0	0	0	0	0	0	0	0	0
	RED(2)	0	0	0	0	1	0	0	0	0	0	0	0	0	0	0	0	0	0
	RED(62)	1	1	1	1	1	0	0	0	0	0	0	0	0	0	0	0	0	0
	RED(63)	1	1	1	1	1	1	0	0	0	0	0	0	0	0	0	0	0	0
Green	Green(0)	0	0	0	0	0	0	0	0	0	0	0	0	0	0	0	0	0	0
	Green(1)	0	0	0	0	0	0	0	0	0	0	0	1	0	0	0	0	0	0
	Green(2)	0	0	0	0	0	0	0	0	0	0	1	0	0	0	0	0	0	0
	Green(62)	0	0	0	0	0	0	1	1	1	1	1	0	0	0	0	0	0	0
	Green(63)	0	0	0	0	0	0	1	1	1	1	1	1	0	0	0	0	0	0
Blue	Blue(0)	0	0	0	0	0	0	0	0	0	0	0	0	0	0	0	0	0	0
	Blue(1)	0	0	0	0	0	0	0	0	0	0	0	0	0	0	0	0	0	1
	Blue(2)	0	0	0	0	0	0	0	0	0	0	0	0	0	0	0	0	1	0
	Blue(62)	0	0	0	0	0	0	0	0	0	0	0	0	1	1	1	1	1	0
	Blue(63)	0	0	0	0	0	0	0	0	0	0	0	0	1	1	1	1	1	1

## 【Note】

- 1) Gray level:  
Color(n) : n is level order; higher n means brighter level.
- 2) DATA:  
1: high , 0: low

## 6. BLOCK DIAGRAM

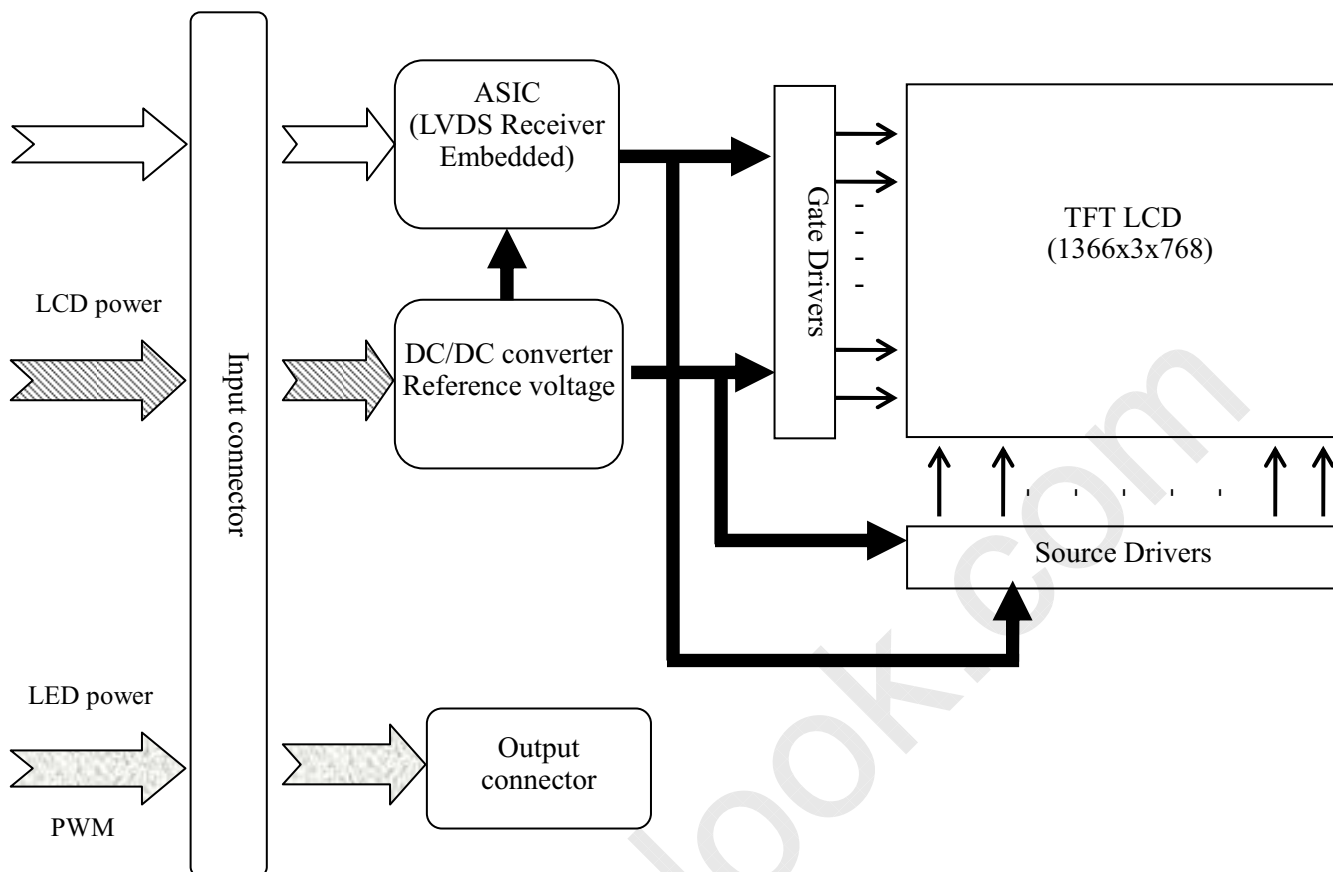

## 7. MECHANICAL SPECIFICATION

### (1) Front side

The tolerance, not show in the figure, is  $\pm 0.5$  mm.

[Unit : mm]

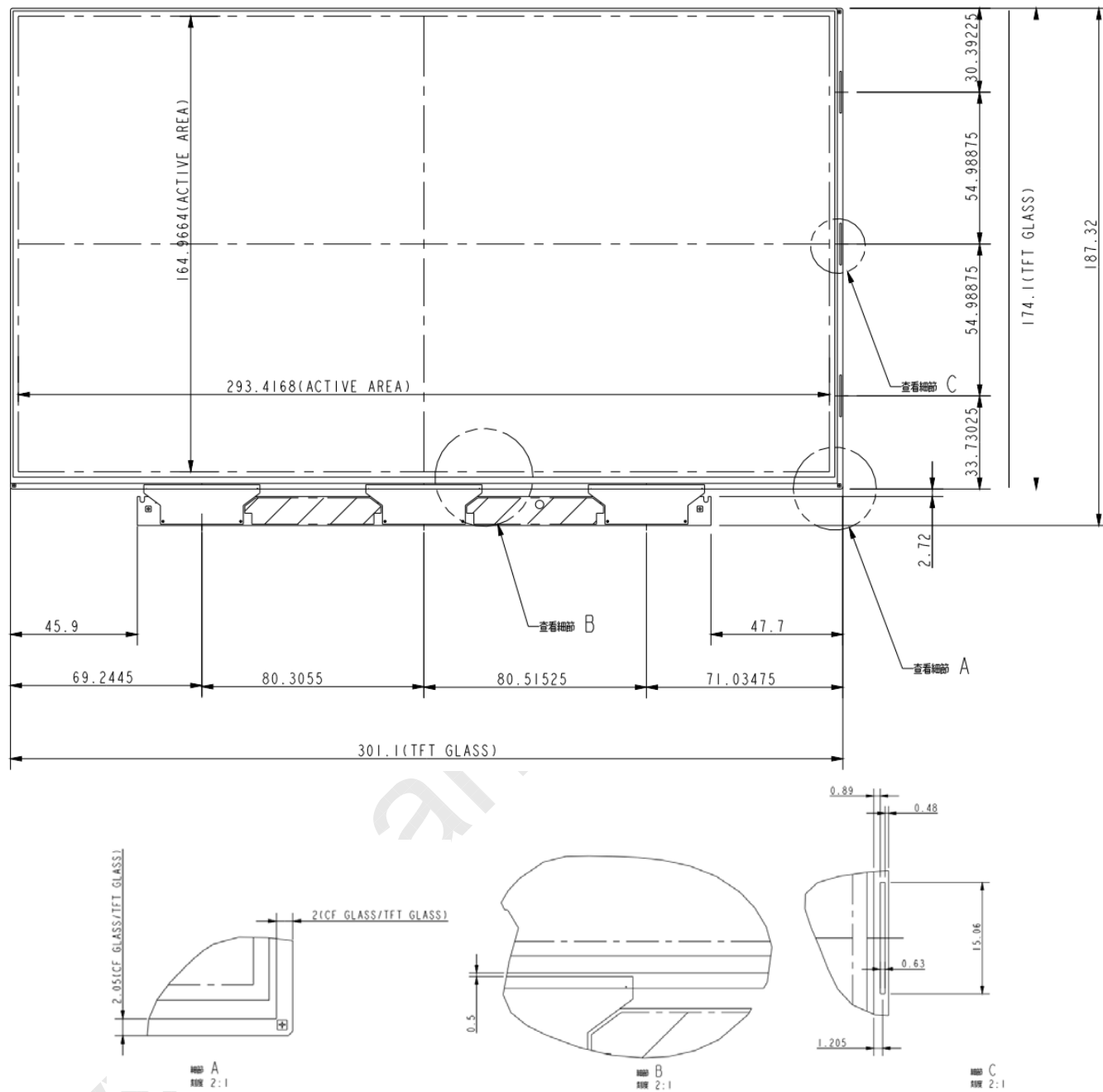

**(2) Rear side**The tolerance, not show in the figure, is  $\pm 0.5$  mm.

[Unit : mm]

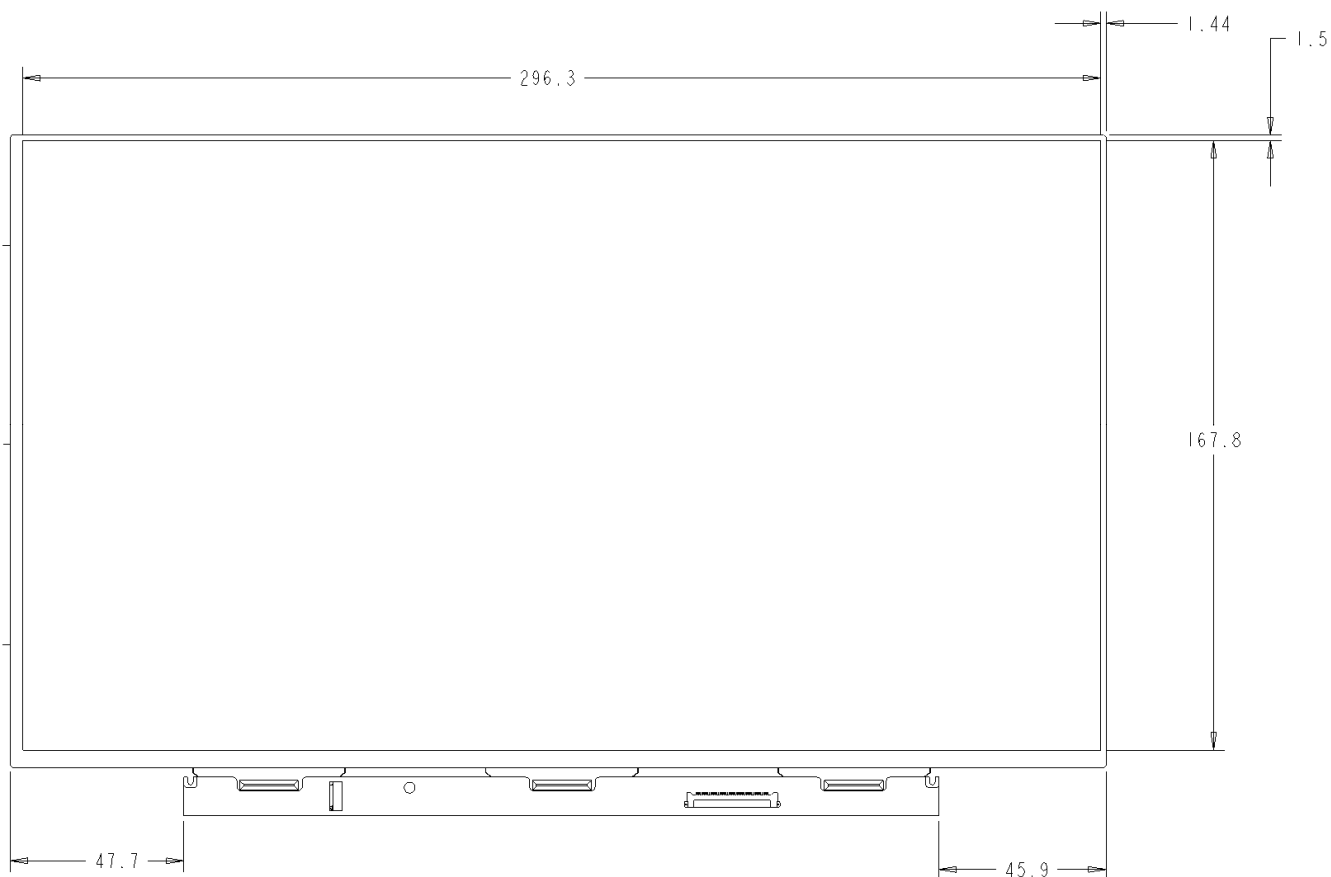



## 8. OPTICAL CHARACTERISTICS

Ta=25°C , VDD=3.3V

ITEM	SYMBOL	CONDITION	MIN	TYP	MAX	UNIT	NOTE	
Contrast Ratio (CEN)	CR	$\theta=\psi=0^\circ$	500	600	-	--	*1) 2)	
Transmittance (CEN)	T%	CPT BLU	-	5.5	-	%	*5)	
Response Time	Tr	$\theta=\psi=0^\circ$	-	8	16	ms	*4)	
	Tf	$\theta=\psi=0^\circ$	-			ms	*4)	
Cross Talk	CT	$\theta=\psi=0^\circ$	-	-	1	%	*5)	
View Angle	Horizontal	$\psi$	CR $\geq$ 10	40/-40	-	-	$^\circ$	*3)
	Vertical	$\theta$		15/-30	-	-	$^\circ$	*3)
Color Coordinate	W	x	$\theta=\psi=0^\circ$ CPTBLU	0.293	0.313	0.333	Color Coordinates	*3)
		y		0.309	0.329	0.349		
	R	x		0.550	0.580	0.610		
		y		0.310	0.340	0.370		
	G	x		0.280	0.310	0.340		
		y		0.520	0.550	0.580		
	B	x		0.125	0.155	0.185		
		y		0.095	0.125	0.155		

Color coordinate and color gamut are measured by SRUL1R, response time is measured by TRD-100, and all the other items are measured by BM-5A (TOPCON). All these items are measured under the dark room condition (no ambient light).

Measurement Condition: IL= 16.5mA (each LED)

**Definition of these measurement items is as follows:**

### \*1) Setup of Measurement Equipment

The LCD module should be turn-on to a stable luminance level to be reached. The measurement should be executed after lighting backlight (CPT BLU) for 20 minutes and in a dark room.

### \*2) Definition of Contrast Ratio

CR=ON (White) Luminance/OFF (Black) Luminance

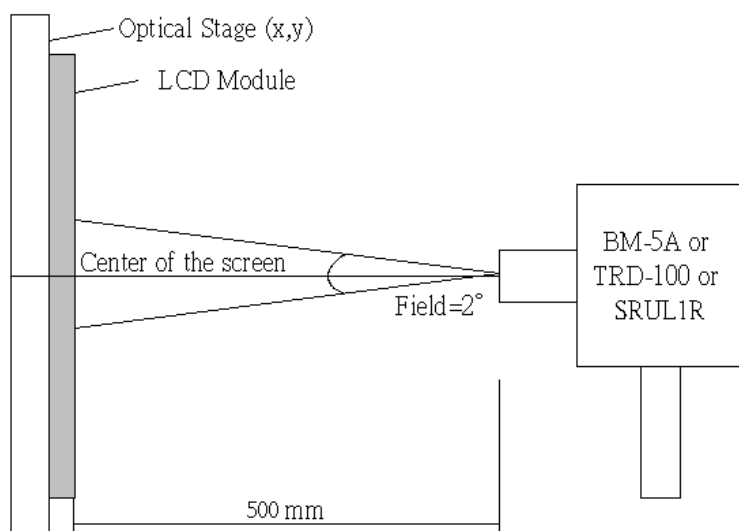

### \*3) Definition of view angle( $\theta$ , $\psi$ )

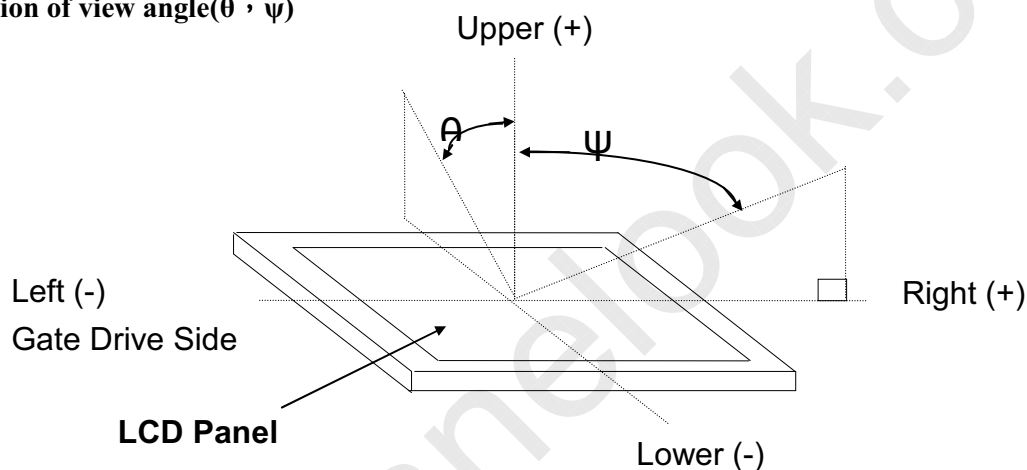

### \*4) Definition of response time

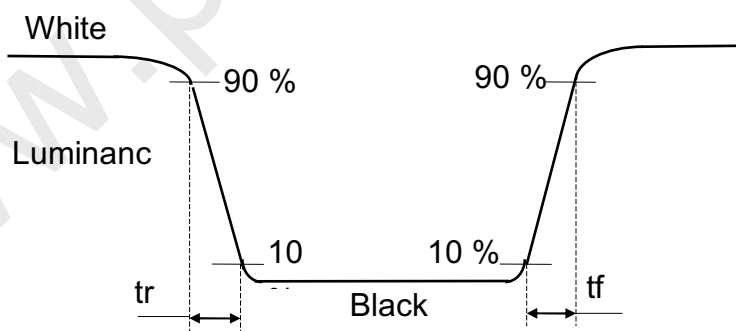

### \*5) Definition of Transmittance (T%)

$$\text{Transmittance} = (\text{Luminance of LCD module} / \text{Luminance of backlight}) * 100\%$$