

# CLAMP2504N

## Low Capacitance Array for Surge & ESD Protection

The CLAMP2504N has a low typical capacitance of 2.4pF and operates with virtually no insertion loss to 1GHz. This makes the device ideal for protection of high-speed data lines such as Firewire, DVI, and gigabit Ethernet interfaces. The low capacitance array configuration allows the user to protect four high-speed data or transmission lines. The low inductance construction minimizes voltage overshoot during high current surges. It may be used to meet the ESD immunity requirements of IEC61000-4-2, Level 4 ( $\pm 15\text{kV}$  air,  $\pm 8\text{kV}$  contact discharge).

It has been specifically designed to protect sensitive components which are connected to high-speed data and transmission lines from overvoltage caused by ESD (electrostatic discharge), CDE (Cable Discharge Events), and lightning.

### Features

- Protects four I/O lines and one Vcc line
- Low capacitance
- Working voltages : 2.5V
- Low leakage current
- Response Time is < 1 ns
- Low capacitance (<5.0pF) for high-speed interfaces
- Meets MSL 3 Requirements
- **Solid-state silicon avalanche technology**
- ROHS compliant
- WeiPan technology

### Main applications

- Digital Visual Interface (DVI)
- 10/100/1000 Ethernet
- IEEE 1394 Firewire Ports
- T1/E1 Secondary Protection
- T3/E3 Secondary Protection
- Projection TV Monitors and Flat Panel Displays
- Notebook Computers
- Projection TV

### Protection solution to meet

- IEC61000-4-2 (ESD)  $\pm 15\text{kV}$  (air),  $\pm 8\text{kV}$  (contact)
- IEC61000-4-4 (EFT) 40A (5/50ns)
- IEC61000-4-5 (Lightning) 17A (8/20 $\mu\text{s}$ )

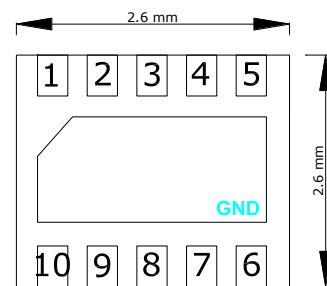

**DFN2626-10L**

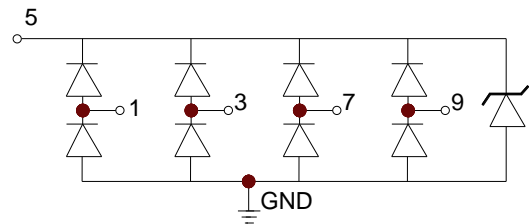
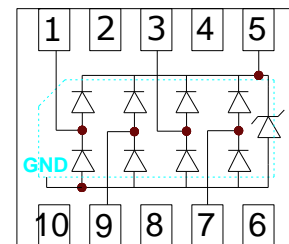

### Ordering Information

Device	Qty per Reel	Reel Size
CLAMP2504N	3000	7 Inch

**Maximum ratings (Temp=25°C Unless Otherwise Specified)**

Parameter	Symbol	Value	Unit
Peak Pulse Power (tp=8/20μs waveform)	P <sub>PPP</sub>	300	Watts
Peak Pulse Current(tp=8/20μs waveform)	I <sub>PP</sub>	17	A
ESD Rating per IEC61000-4-2:	Contact	8	KV
	Air	15	
Lead Soldering Temperature	T <sub>L</sub>	260 (10 sec.)	°C
Operating Temperature Range	T <sub>J</sub>	-55 ~ 150	°C
Storage Temperature Range	T <sub>STG</sub>	-55 ~ 150	°C

Maximum ratings are those values beyond which device damage can occur. Maximum ratings applied to the device are individual stress limit values (not normal operating conditions) and are not valid simultaneously. If these limits are exceeded, device functional operation is not implied, damage may occur and reliability may be affected.

\*Other voltages may be available upon request.

1. Non-repetitive current pulse, per Figure 1.

**Electrical characteristics (Temp=25°C Unless Otherwise Specified)**

Symbol	Parameter	Conditions	Min.	Typ.	Max.	Units
V <sub>RWM</sub>	Reverse Working Voltage	Any I/O to Ground			2.5	V
V <sub>PT</sub>	Punch-Through Voltage	I <sub>PT</sub> = 2μA, Any I/O to Ground	2.7			V
V <sub>SB</sub>	Snap-Back Voltage	I <sub>SB</sub> = 50mA, Any I/O to Ground	2.0			V
I <sub>R</sub>	Reverse Leakage Current	V <sub>RWM</sub> = 2.5V, Any I/O to Ground			0.5	μA
V <sub>C</sub>	Clamping Voltage	I <sub>PP</sub> = 1A, tp = 8/20μs, any I/O pin to Ground			5.5	V
		I <sub>PP</sub> = 15A, tp = 8/20μs, any I/O pin to Ground			15	V
I <sub>PP</sub>	Peak Pulse Current	tp = 8/20μs			17	A
C <sub>J</sub>	Junction Capacitance	V <sub>R</sub> = 0V, f = 1MHz, between I/O pins		1.3	2.7	pF
		V <sub>R</sub> = 0V, f = 1MHz, any I/O pin to Ground		2.4	5	pF

Junction capacitance is measured in VR=0V, F=1MHz

Symbol	Parameter
V <sub>RWM</sub>	Working Peak Reverse Voltage
V <sub>PT</sub>	Punch-Through Voltage@ I <sub>PT</sub>
V <sub>SB</sub>	Snap-Back Voltage@ I <sub>SB</sub>
V <sub>C</sub>	Clamping Voltage @ I <sub>PP</sub>
I <sub>T</sub>	Test Current
I <sub>RM</sub>	Leakage current at V <sub>RWM</sub>
I <sub>PP</sub>	Peak pulse current
C <sub>J</sub>	Junction Capacitance

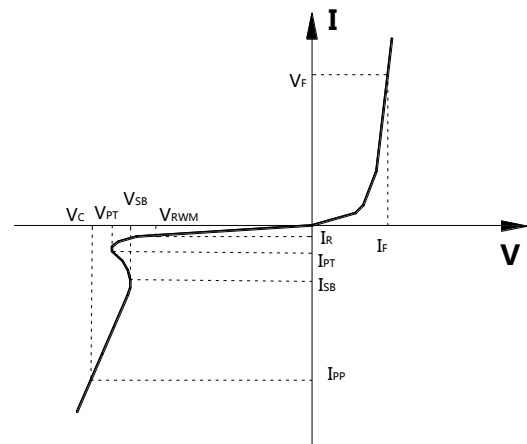

Typical electrical characteristic applications

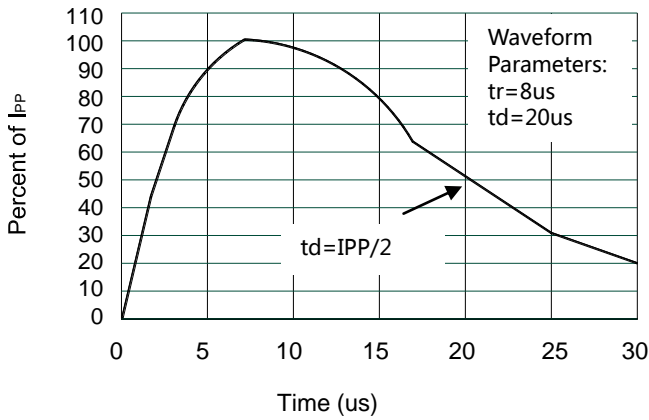

Pulse Waveform

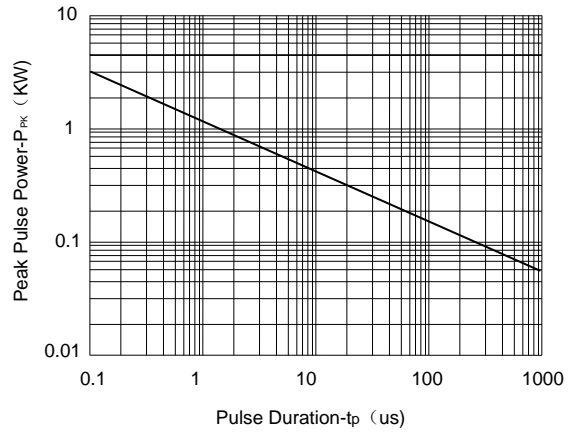

Non-Repetitive Peak Pulse Power vs. Pulse Time

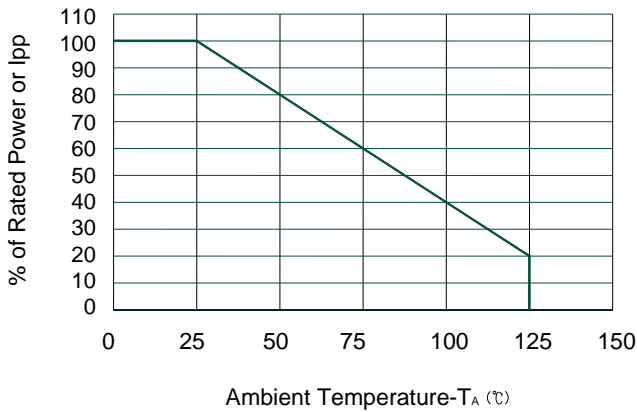

Power Derating Curve

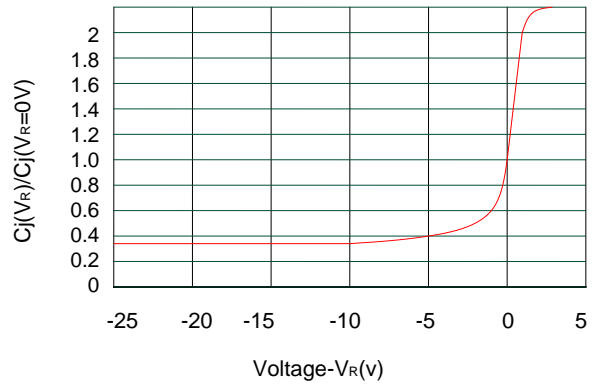

Junction Capacitances. Reverse Voltage

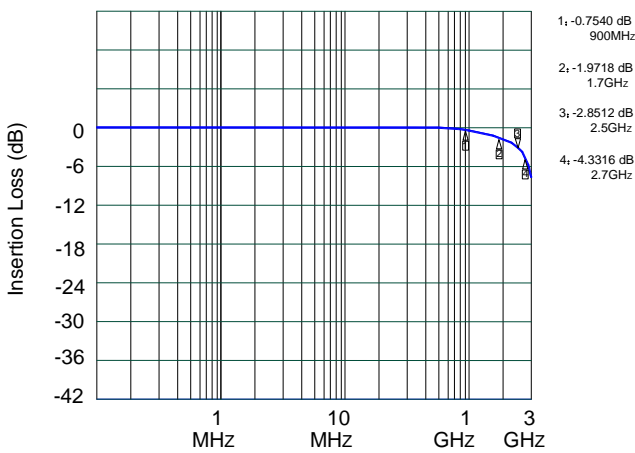

Insertion Loss S21

**Typical applications**

10/100/1000  
Ethernet PHY

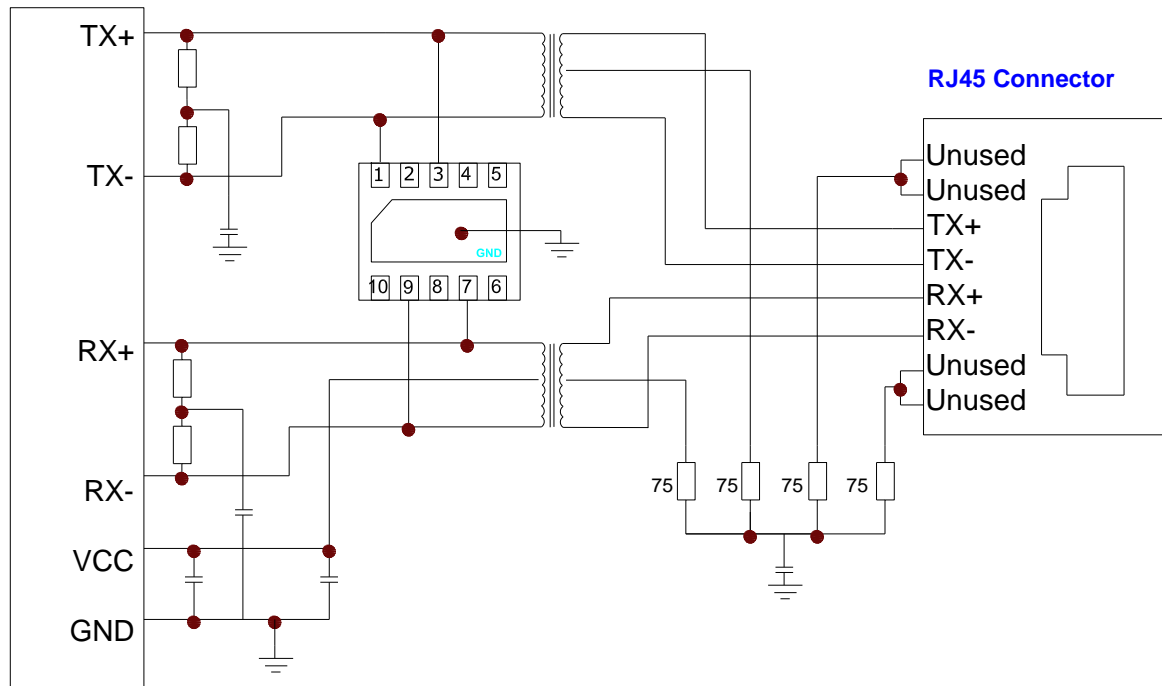

**10/100/1000 Ethernet Protection**

**Considerations:**

- Some Ethernet ports only need be protected for ESD and not for lightning induced transients
  - These are sometimes referred to as “2M” ports or 2 Meter ports that have very short CAT5 cable installations
- Parasitic capacitance should be taken into account especially for 1GbE
- The 4 data lines below (Tx± and Rx±) are being protected against ESD by a low capacitance CLAMP2504N which is suitable for all Ethernet data rates
  - In fact, any low capacitance CLAMP2504N device is suitable for any “ESD only” Ethernet application
- 1000Mbps Ethernet (or 1GbE) will require 8 channels of protection for the 4 differential pair so the below scheme should be replicated for the remaining 2 data pair

**Package Information**

**DFN2626-10L**

**Mechanical Data**

Case:DFN2626-10L

Case Material: Molded Plastic. UL Flammability

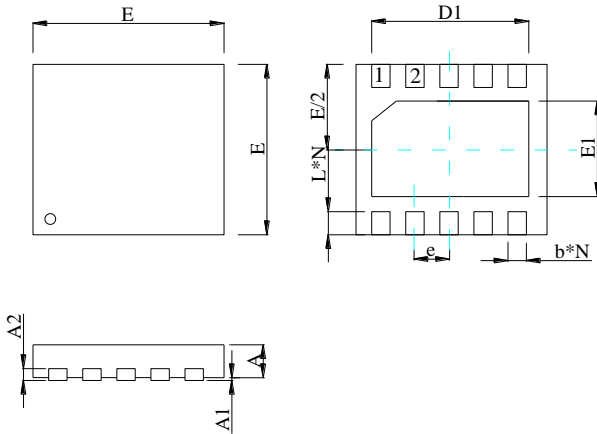

DIM	Millimeters		Inches	
	Min	Max	Min	Max
A	0.5	0.60	0.020	0.024
A1	0.05		0.002	
A2	0.15REF		0.006REF	
b	0.20	0.30	0.008	0.012
D1	2.00	2.25	0.079	0.089
E	2.55	2.60	0.100	0.102
E1	1.11	1.36	0.044	0.054
e	0.50BSC		0.020BSC	
L	0.25	0.45	0.010	0.018
N	10		10	

**Recommended Pad outline**

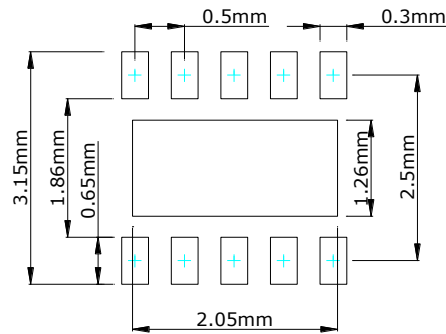

**DFN2626-10L Reel Dim**

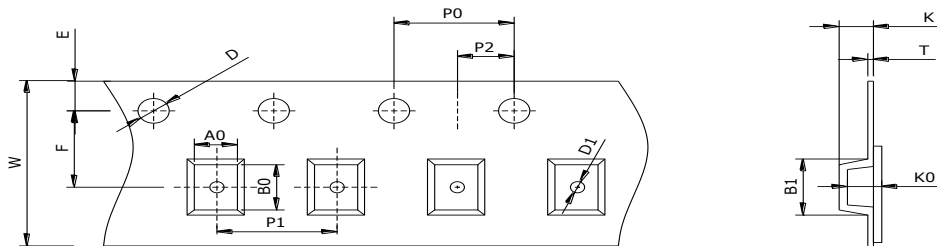

Package	Chip Size (mm)	Pocket Size B0×A0×K0(mm)	Tape Width	Reel Diameter	Quantity Per Reel	P0	P1
DFN2626-10L	2.6×2.6×0.65	2.80×2.80×0.85	8mm	178mm(7")	3000	4mm	4mm
D0	D1	E	F	K	T	W	
1.5mm	0.5mm	1.75mm	3.5mm	0.65mm	0.2mm	8mm	