

CM Series



Due to technical expertise of accurately wire wound skill, these chip inductors are designed as filtering impedance matching, resonance and choke circuits for RF designer. The stand series as well as customer design to meet your needs of telecom & wireless products.

Features

- RoHS Compliant
- Ceramic body and wire wound construction provide high SRFs.
- These ultra – compact inductors provided exceptional Q value, even at high frequencies.
- Their ceramic construction delivers the highest possible SRFs as well as high Q value
- Low DC resistance design is ideal for low loss, high output and low power consumption
- CM series is standard parts for RF designers.

Applications

RF products for cellular phone, GPS receiver, Base Station, Repeater, Wireless LAN/ Mouse/ Keyboard/ earphone, remote control, security system and other RF modules.

Product Identification

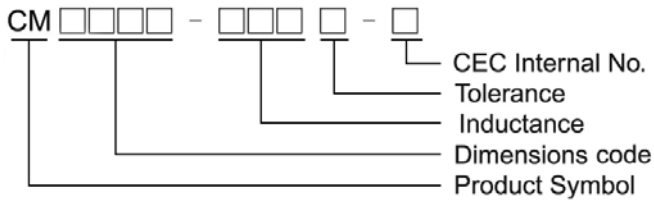

Shapes and Dimensions / Recommended Pattern

CM0402

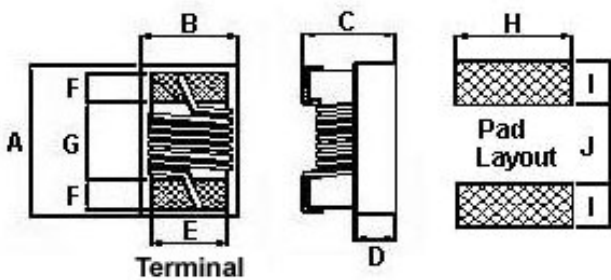

CM0603

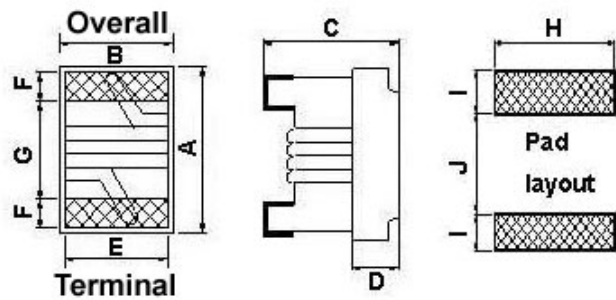

Dimensions

		A Max	B Max	C Max	D	E	F	G	H	I	J
CM0402	inch	0.043	0.024	0.024	0.010	0.016	0.008	0.024	0.026	0.012	0.023
	mm	1.10	0.60	0.60	0.25	0.40	0.20	0.60	0.66	0.30	0.58
CM0603	inch	0.071	0.044	0.040	0.016	0.028	0.012	0.037	0.040	0.021	0.033
	mm	1.80	1.12	1.02	0.40	0.70	0.30	0.95	1.02	0.54	0.84

## Electrical Characteristics

Part Number	Inductance (nH)	Test Frequency (MHz)	Tolerance (±%)	Q Min	Test Frequency (MHz)	SRF (GHz) Min	Rdc (Ω) Max	Irms (mA) Max
CM0402-1N5□-S	1.5	100	C / S	10	250	18.0	0.03	1000
CM0402-2N4□-S	2.4	100	C / S	20	250	15.0	0.05	850
CM0402-2N7□-S	2.7	100	C / S	20	250	15.0	0.05	850
CM0402-3N9□-S	3.9	100	C / S	25	250	10.0	0.07	750
CM0402-4N1□-S	4.1	100	C / S	25	250	10.0	0.07	750
CM0402-4N3□-S	4.3	100	C / S	25	250	10.0	0.07	750
CM0402-4N7□-S	4.7	100	C / S	25	250	8.0	0.07	750
CM0402-5N1□-S	5.1	100	C / S	25	250	8.0	0.12	600
CM0402-5N8□-S	5.8	100	C / S	25	250	8.0	0.12	700
CM0402-6N2□-S	6.2	100	C / S	25	250	8.0	0.09	700
CM0402-6N8□-S	6.8	100	G / J	25	250	6.0	0.09	700
CM0402-7N3□-S	7.3	100	G / J	25	250	6.0	0.13	570
CM0402-7N5□-S	7.5	100	G / J	25	250	6.0	0.13	570
CM0402-8N2□-S	8.2	100	G / J	25	250	5.5	0.14	540
CM0402-8N7□-S	8.7	100	G / J	25	250	5.5	0.14	540
CM0402-9N1□-S	9.1	100	G / J	25	250	5.5	0.14	540
CM0402-10N□-S	10	100	G / J	25	250	5.5	0.17	500
CM0402-11N□-S	11	100	G / J	30	250	5.5	0.14	500
CM0402-12N□-S	12	100	G / J	30	250	5.5	0.14	500
CM0402-13N□-S	13	100	G / J	25	250	5.0	0.21	430
CM0402-15N□-S	15	100	G / J	30	250	5.0	0.16	460

- When ordering, please specify tolerance and packaging codes.
- Tolerance : G = ±2% , J = ±5% , K = ±10% , C = ±0.2nH , S = ±0.3nH
- L , Q : Agilent/HP4991A+Agilent/HP16197A @250MHz
- SRF : Agilent/HP8753D / Agilent/HP8722ES
- Rdc : Chroma16502
- Irms for a 15°C rise above 25°C ambient.
- Operating temperature range from -40°C to 125°C . (Including self - temperature rise)

Typical **L** vs. **F** Frequency

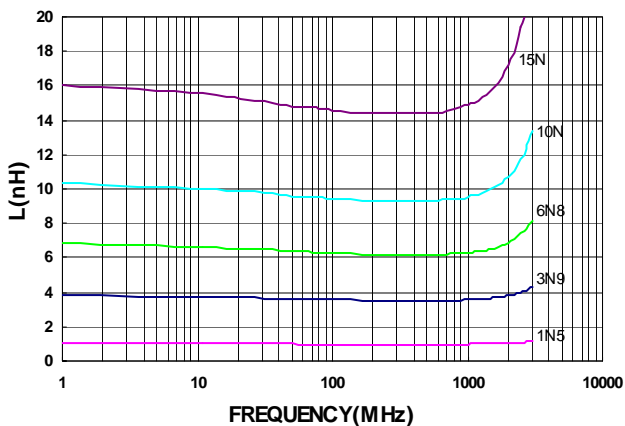

Typical **Q** vs. **F** Frequency

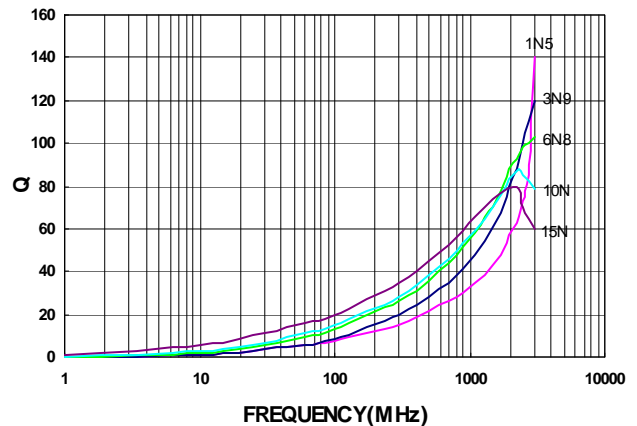

## Electrical Characteristics

Part Number	Inductance (nH)	Test Frequency (MHz)	Tolerance (±%)	Q Min	Test Frequency (MHz)	SRF (GHz) Min	Rdc (Ω) Max	Irms (mA) Max
CM0603-2N2□-S	2.2	100	S	16	250	6.0	0.049	700
CM0603-3N6□-S	3.6	100	C / S	25	250	6.0	0.059	850
CM0603-3N9□-S	3.9	100	C / S	35	250	6.0	0.059	850
CM0603-4N3□-S	4.3	100	C / S	35	250	6.0	0.059	850
CM0603-4N7□-S	4.7	100	J / K	35	250	6.0	0.059	850
CM0603-5N6□-S	5.6	100	J / K	35	250	6.0	0.082	750
CM0603-6N2□-S	6.2	100	J / K	35	250	6.0	0.082	750
CM0603-6N8□-S	6.8	100	J / K	35	250	6.0	0.082	750
CM0603-7N5□-S	7.5	100	J / K	35	250	6.0	0.082	750
CM0603-8N2□-S	8.2	100	J / K	35	250	6.0	0.110	650
CM0603-8N7□-S	8.7	100	J / K	35	250	6.0	0.110	650
CM0603-9N1□-S	9.1	100	J / K	35	250	6.0	0.110	650
CM0603-10N□-S	10	100	G / J / K	35	250	6.0	0.110	650
CM0603-11N□-S	11	100	G / J / K	35	250	6.0	0.110	650
CM0603-12N□-S	12	100	G / J / K	35	250	6.0	0.130	600
CM0603-13N□-S	13	100	G / J / K	35	250	6.0	0.130	600
CM0603-15N□-S	15	100	G / J / K	40	250	6.0	0.130	600

- When ordering, please specify tolerance and packaging codes.
- Tolerance : G = ±2% , J = ±5% , K = ±10% , C = ±0.2nH , S = ±0.3nH
- L , Q : Agilent/HP4991A+Agilent/HP16197A @250MHz
- SRF : Agilent/HP8753D / Agilent/HP8722ES
- Rdc : Chroma16502
- Irms for a 15°C rise above 25°C ambient.
- Operating temperature range from -40°C to 125°C. (Including self - temperature rise)

Typical **L** vs. **Frequency**

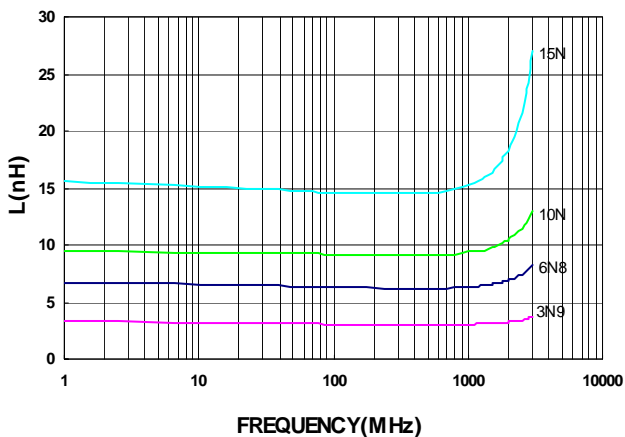

Typical **Q** vs. **Frequency**

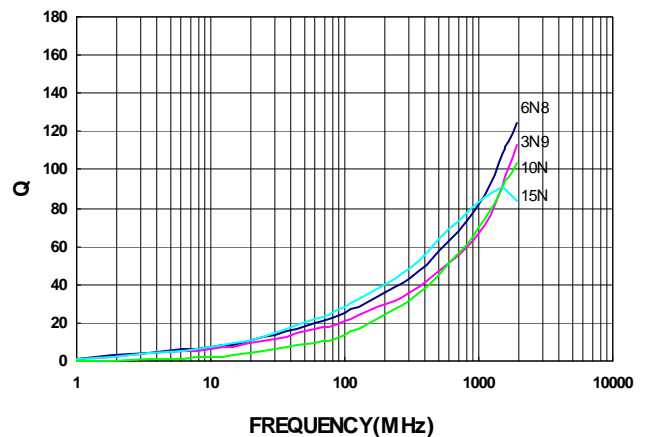

Packaging Specifications

Tape Dimensions

Figure 1

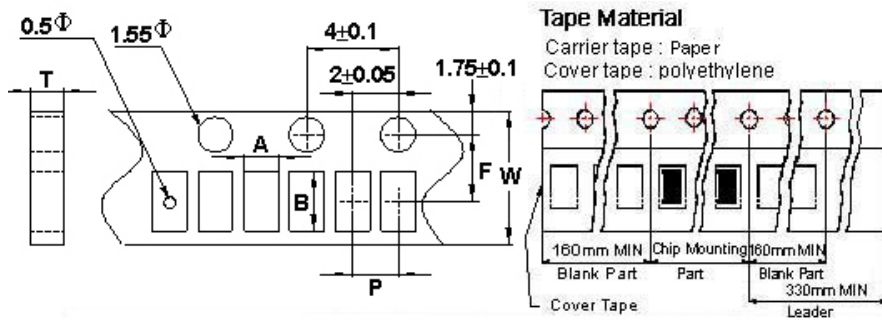
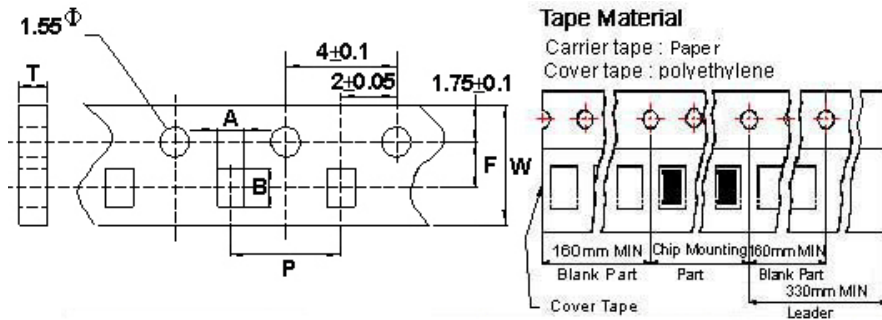
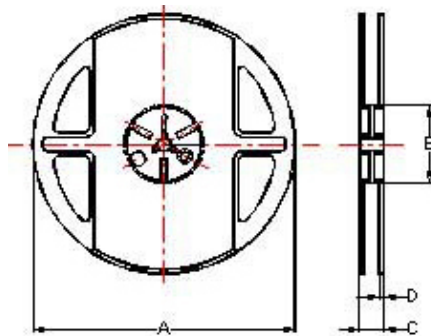

Figure 2



Reel Dimensions



Dimensions in mm

TYPE	Fig.	Tape Dimensions						Reel Dimensions				Quantity PCS / Reel
		A	B	T	W	P	F	A	B	C	D	
CM0402	1	0.74	1.23	0.68	8	2	3.5	178	60	12	1.5	4000
CM0603	2	1.16	1.85	0.95	8	4	3.5	178	60	12	1.5	4000