

## 1 and 2 Channel *PicoGuard*™ AC Signal ESD Protector

### Features

- Single channel ESD protection for an AC signal up to  $\pm 5V$  for 0.25W transmit power
- Connect two channels in series for signals up to  $\pm 10V$  (1W transmit power)
- $\pm 8kV$  ESD protection per IEC 61000-4-2 contact discharge
- Sub-1pF loading capacitance
- Minimal variation with voltage and temperature
- Can withstand over 1000 ESD strikes at 8kV
- DFN-3, SOT23-3 and MSOP-8 package options
- Lead-free versions available

### Applications

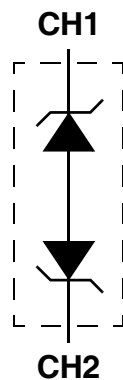
- RF switch and amplifier protection
- RF modules and RF IC protection
- Wireless handsets and WLAN
- High-speed AC signals for Gbit Ethernet, etc.

### Product Description

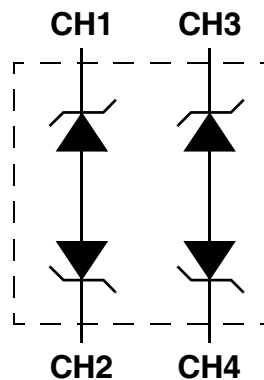
The CM1214 *PicoGuard*™ ESD protector is used to protect bipolar signal lines against electrostatic discharge (ESD). The CM1214 allows operation in high-speed environments with signals levels up to  $\pm 5V$ . The low sub-1pF loading capacitance makes the CM1214-01DF/DE and CM1214-01ST/SO ideal for protecting high-speed interfaces including RF switches and amplifiers. The CM1214-02MS/MR is ideal for dual high-speed signal pairs used in Gigabit Ethernet, ADSL, etc. The CM1214-02MS/MR can also be used for higher transmit voltage applications by connecting the two channels in series.

The CM1214-01DF/DE and the CM1214-01ST/SO are single channel ESD protectors available in a 3-lead DFN-3 and SOT23-3 packages respectively. The CM1214-01DF/DE is housed in a very small form factor DFN package that provides up to 20% and 32% board space savings when it is used in place of SC70 and SOT23 packages. The CM1214-02MS/MR is a dual channel ESD protector and is available in an 8-lead MSOP-8 package. All three devices are available with optional lead-free finishing.

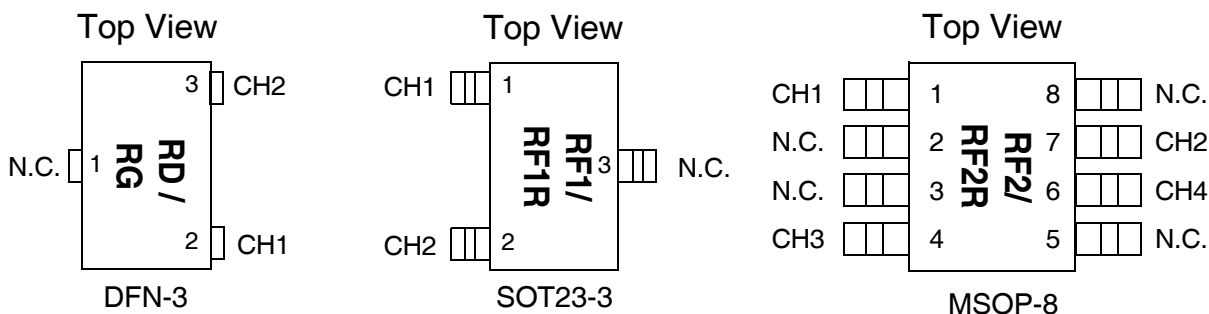
### Electrical Schematics



CM1214-01ST/SO  
CM1214-01DF/DE



CM1214-02MS/MR

**PACKAGE / PINOUT DIAGRAMS**


Note: These drawings are not to scale.

**SOT23-3 PACKAGE PIN DESCRIPTIONS**

PIN	NAME	DESCRIPTION
1	CH1	ESD Channel
2	CH2	ESD Channel
3	N.C.	No connect

**DFN-3 PACKAGE PIN DESCRIPTIONS**

PIN	NAME	DESCRIPTION
1	N.C.	No connect
2	CH1	ESD Channel
3	CH2	ESD Channel

**MSOP-8 PACKAGE PIN DESCRIPTIONS**

PIN	NAME	DESCRIPTION
1	CH1	ESD Channel
2	N.C.	No connect
3	N.C.	No connect
4	CH3	ESD Channel
5	N.C.	No connect
6	CH4	ESD Channel
7	CH2	ESD Channel
8	N.C.	No connect

**Ordering Information**
**PART NUMBERING INFORMATION**

Pins	Package	Standard Finish		Lead-free Finish	
		Ordering Part Number <sup>1</sup>	Part Marking	Ordering Part Number <sup>1</sup>	Part Marking
3	DFN	CM1214-01DF	RD	CM1214-01DE	RG
3	SOT23	CM1214-01ST	RF1	CM1214-01SO	RF1R
8	MSOP	CM1214-02MS	RF2	CM1214-02MR	RF2R

Note 1: Parts are shipped in Tape &amp; Reel form unless otherwise specified.

## Specifications

### ABSOLUTE MAXIMUM RATINGS

PARAMETER	RATING	UNITS
DC Voltage between CH pins	7	V
Operating Temperature Range	-40 to +85	°C
Storage Temperature Range	-65 to +150	°C
Package Power Rating		
DFN-3 Package (CM1214-01DF/DE)	TBD	mW
SOT23-3 Package (CM1214-01ST/SO)	225	mW
MSOP8 Package (CM1214-02MS/MR)	400	mW

### STANDARD OPERATING CONDITIONS

PARAMETER	RATING	UNITS
Operating Temperature Range	-40 to +85	°C

### ELECTRICAL OPERATING CHARACTERISTICS (SEE NOTE 1)

SYMBOL	PARAMETER	CONDITIONS	MIN	TYP	MAX	UNITS
$V_{ST}$	Standoff Voltage	$I=10\mu A$		$\pm 7$		V
$V_{ESD}$	ESD Voltage Protection Peak discharge voltage between CH pins a) Contact discharge per IEC 61000-4-2 standard	Notes 2, 3 and 4	$\pm 8$			kV
$I_{LEAK}$	Channel Leakage Current	$T_A=25^\circ C$ , 5.5V between CH pins		$\pm 0.1$	$\pm 1.0$	$\mu A$
$R_{DYN}$	Dynamic Resistance	$I = 1A$ , $T_A=25^\circ C$ ;		1.5		$\Omega$
$C_{IN}$	Channel Input Capacitance	Measured at 1 MHz between CH pins; Note 2 applies				
	Voltage between CH pins = 0V		0.5	0.8	1.2	pF
	Voltage between CH pins = 5V		0.5	0.8	1.2	pF

Note 1: All parameters specified at  $T_A = -40^\circ C$  to  $+85^\circ C$  unless otherwise noted.

Note 2: These parameters guaranteed by design and characterization.

Note 3: Standard IEC 61000-4-2 with  $C_{Discharge} = 150pF$ ,  $R_{Discharge} = 330\Omega$ .

Note 4: From CH pin with other CH pin grounded.

Note 5: No Connect pins are left open for all tests.

## Performance Information

### Typical Capacitance Characteristics vs. Voltage

Figure 1 illustrates how the loading capacitance remains mainly flat across the voltage range from 0V to 5V, the voltage between CH pins.

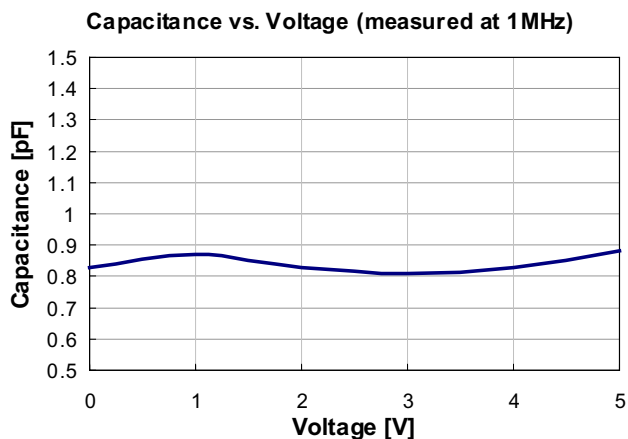


Figure 1. CM1214 Capacitance vs. Voltage

### Typical Voltage Current (VI) Characteristics (low current)

Figure 2 shows how the CM1214 experiences a symmetrical I/V curve, without any snapback or trigger voltage. It gradually starts to turn on at about 6V and clamps above 7V.

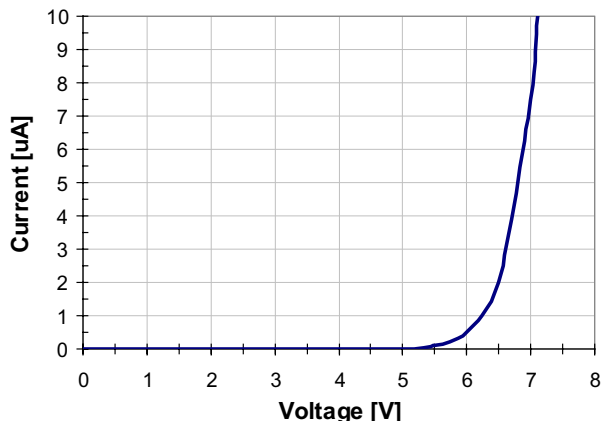


Figure 2. CM1214 VI Characteristics, Low Current

### Typical Voltage-Current (VI) Characteristics (high current, pulse condition)

Figure 3 shows how the CM1214 experiences a symmetrical I/V curve, without any snapback or trigger voltage. The curve shows only one polarity.

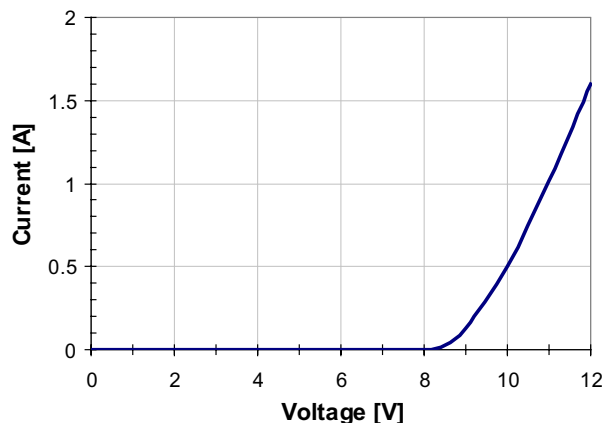


Figure 3. CM1214 VI Characteristics, Low Current, Pulse (clamping) Condition

### Performance Information (cont'd)

Typical Filter Performance (nominal conditions unless specified otherwise, 50 Ohm Environment)

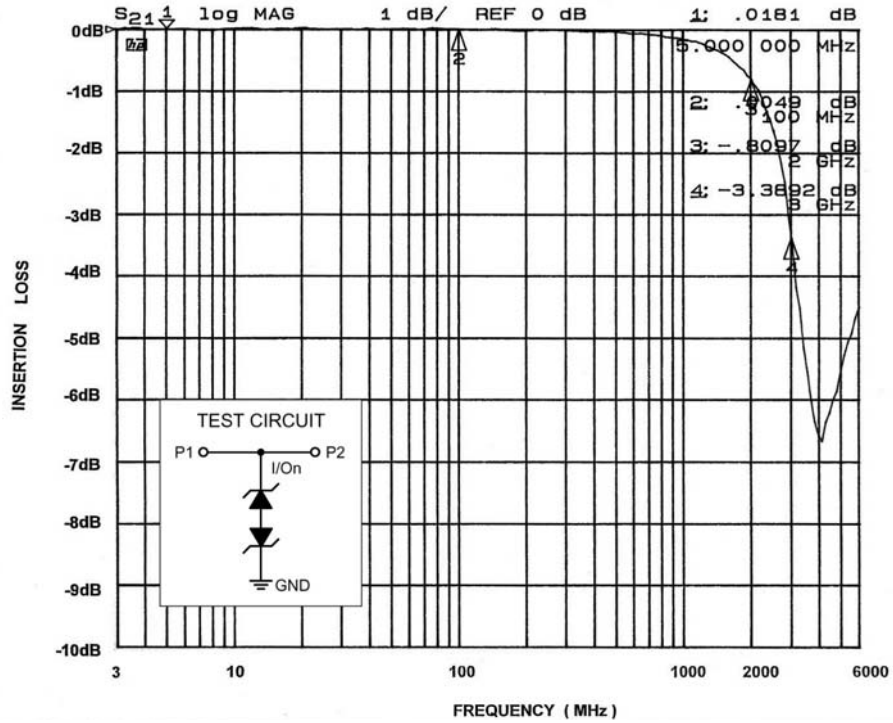


Figure 4. Insertion Loss vs. Frequency (0V DC Bias)

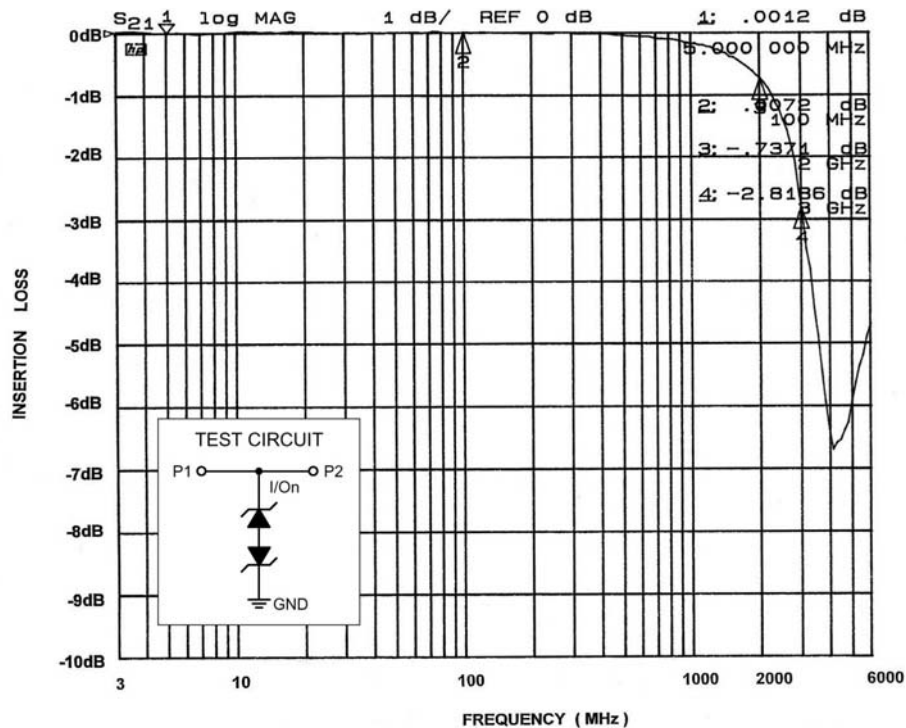


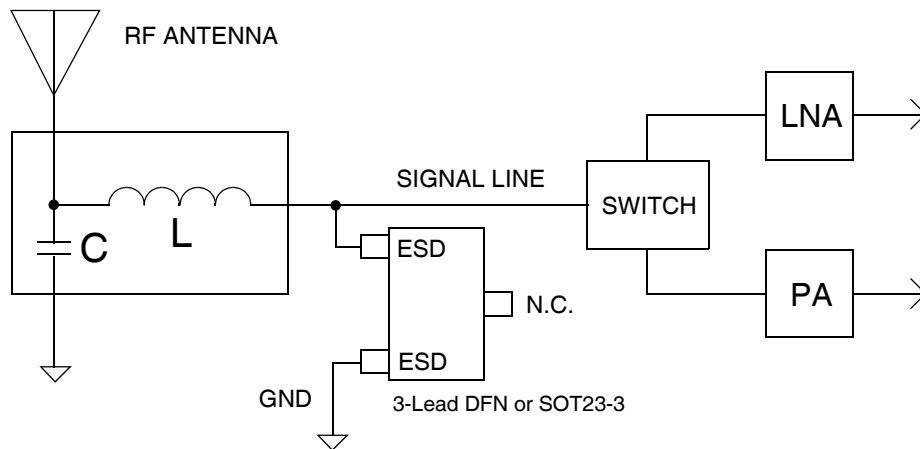
Figure 5. Insertion Loss vs. Frequency (2.5V DC Bias)

### Application Information

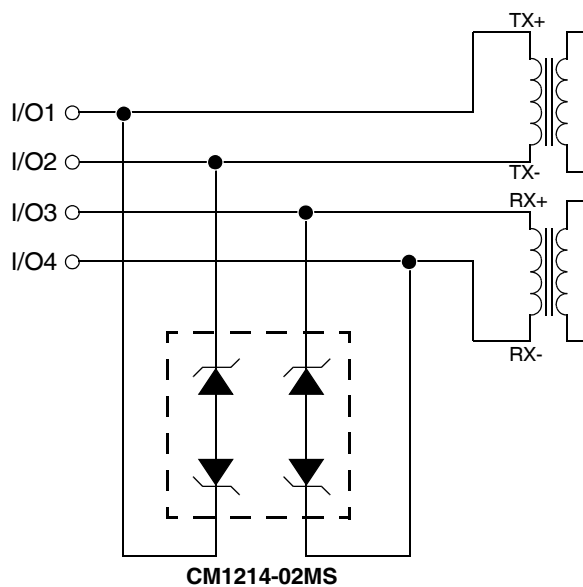
The CM1214-01ST/SO and the CM1214-01DF/DE protect a single bipolar signal line, such as is found in RF circuits. One I/O pin (pin 1 for example) is connected to the signal line to be protected, and the other I/O pin is tied to GND. It is important to have a solid ground connection in order to reduce the clamping voltage. Pin 3 of the 3-lead SOT23 (Pin 1 of the 3-lead DFN) must be left open (not connected on the PCB).

The CM1214-02MS/MR protects two bipolar lines, such as for Gbit Ethernet. The PCB traces underneath the package connect across to the corresponding pins, i.e., pin 1 to pin 8 etc.

Any disturbance on the line above or below the stand-off voltage is clamped.

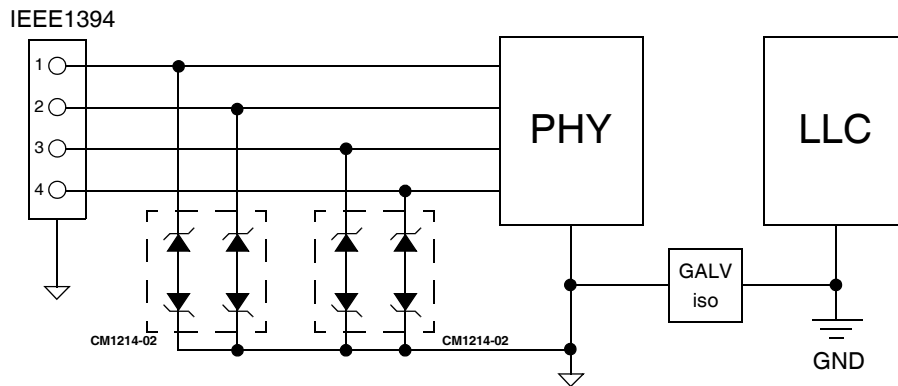


**Figure 6. Typical Application - RF Switch and Amplifier Protection, CM1214-01ST/SO/DF/DE in 3-lead DFN or SOT23**



**Figure 7. Typical Application - Ethernet Protection, CM1214-02MS/MR in 8-lead MSOP**

**Application Information (cont'd)**



Keep the ESD devices on the PHY side of the galvanic isolation and inside the  $V_{CC}$  domain of the PHY controller.

**Figure 8. Typical Application - IEEE1394 Protection, CM1214-02MS/MR in 8-lead MSOP**

## Mechanical Details

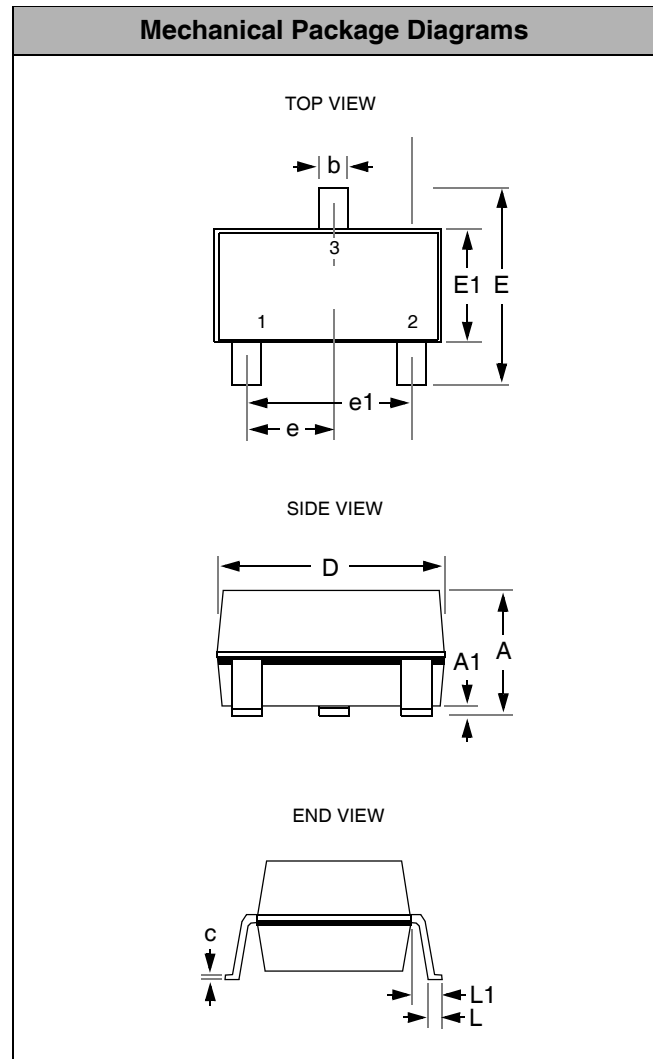
The CM1214 is supplied in DFN-03, SOT23-3 and MSOP-8 packages. Dimensions are presented below.

### SOT23-3 Mechanical Specifications

Dimensions for CM1214-01ST/SO supplied in a 3-pin SOT23 package are presented below.

For complete information on the SOT23-3, see the California Micro Devices SOT23 Package Information document.

PACKAGE DIMENSIONS				
Package	SOT23-3 (JEDEC name is TO-236)			
Pins	3			
Dimensions	Millimeters		Inches	
	Min	Max	Min	Max
<b>A</b>	0.89	1.12	0.0350	0.0441
<b>A1</b>	0.01	0.10	0.0004	0.0039
<b>b</b>	0.30	0.50	0.0118	0.0197
<b>c</b>	0.08	0.20	0.0031	0.0079
<b>D</b>	2.80	3.04	0.1102	0.1197
<b>E</b>	2.10	2.64	0.0827	0.1039
<b>E1</b>	1.20	1.40	0.0472	0.0551
<b>e</b>	0.95 BSC		0.0374 BSC	
<b>e1</b>	1.90 BSC		0.0748 BSC	
<b>L</b>	0.40	0.60	0.0157	0.0236
<b>L1</b>	0.54 REF		0.0213 REF	
<b># per tape and reel</b>	3000 pieces			
Controlling dimension: millimeters				



**Package Dimensions for SOT23-3.**



**Mechanical Details (cont'd)**

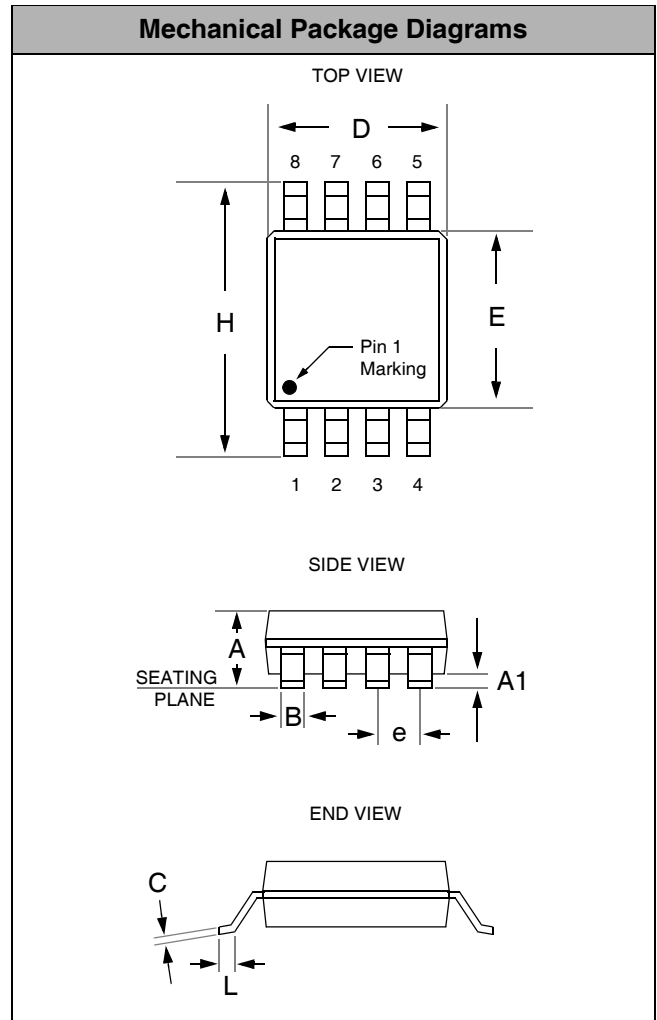
**MSOP-8 Mechanical Specifications:**

The CM1214-02MS/MR is supplied in an 8-pin MSOP package. Dimensions are presented below.

For complete information on the MSOP-8 package, see the California Micro Devices MSOP Package Information document.

PACKAGE DIMENSIONS				
Package	MSOP			
Pins	8			
Dimensions	Millimeters		Inches	
	Min	Max	Min	Max
A	0.87	1.17	0.034	0.046
A1	0.05	0.25	0.002	0.010
B	0.30 (typ)		0.012 (typ)	
C	0.18		0.007	
D	2.90	3.10	0.114	0.122
E	2.90	3.10	0.114	0.122
e	0.65 BSC		0.025 BSC	
H	4.78	4.98	0.188	0.196
L	0.52	0.54	0.017	0.025
# per tube	80 pieces*			
# per tape and reel	4000 pieces			
Controlling dimension: inches				

\* This is an approximate amount which may vary.



**Package Dimensions for MSOP-8**

## Mechanical Details (cont'd)

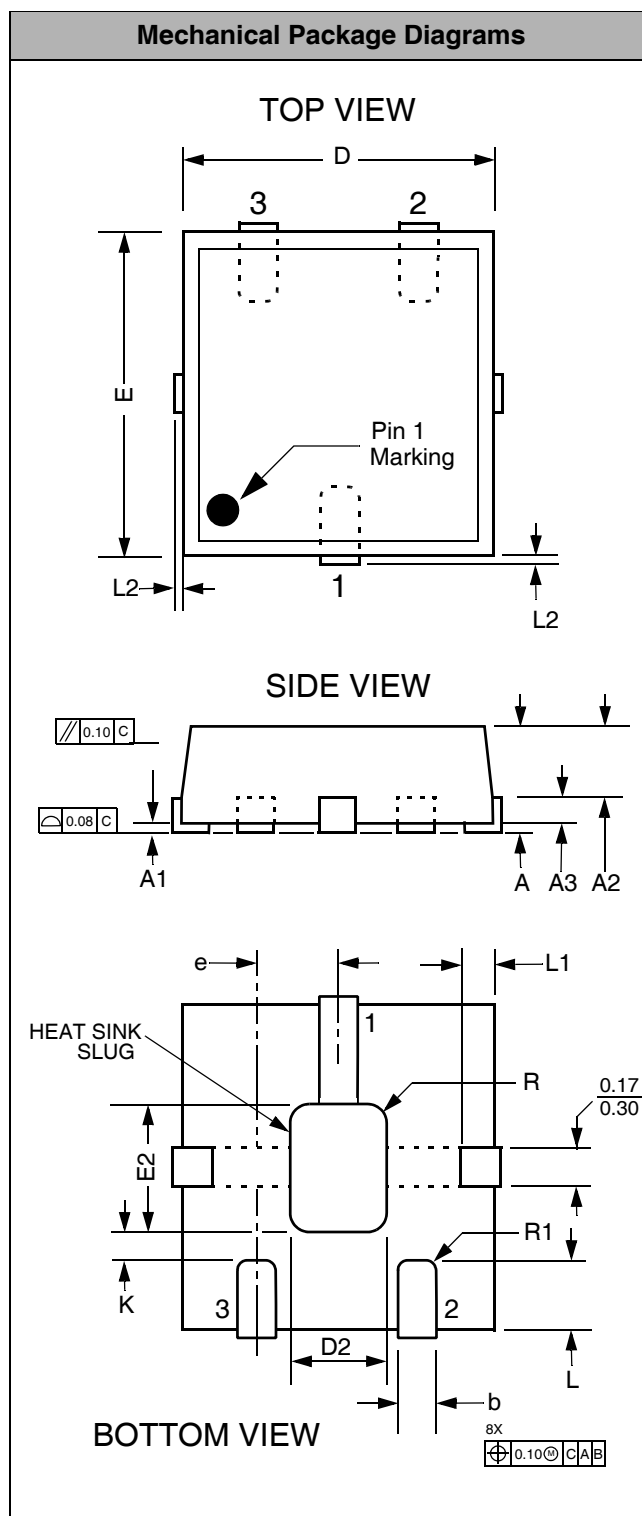
### DFN-03 Mechanical Specifications

The CM1214-01DE/DF is supplied in a 3-lead DFN package. Dimensions are presented below.

For complete information, see the California Micro Devices DFN Package Information document.

PACKAGE DIMENSIONS						
Package	DFN					
JEDEC No.	MO-229 (Var. VCCC-3F) <sup>†</sup>					
Leads	3					
Dim.	Millimeters			Inches		
	Min	Nom	Max	Min	Nom	Max
<b>A</b>	0.800	0.900	1.00	0.031	0.035	0.039
<b>A1</b>	0.000	0.025	0.050	0.000	0.001	0.002
<b>A2</b>	0.650	0.700	0.750	0.026	0.028	0.030
<b>A3</b>	0.150	0.200	0.250	0.006	0.008	0.010
<b>b</b>	0.180	0.200	0.280	0.007	0.009	0.011
<b>D</b>	2.00 BSC			0.079 BSC		
<b>D2</b>	1.220	1.320	1.420	0.048	0.051	0.056
<b>E</b>	2.00 BSC			0.079 BSC		
<b>E2</b>	0.790	0.890	0.990	0.031	0.035	0.040
<b>e</b>		0.65			0.020	
<b>K</b>	0.20			0.008		
<b>L</b>	0.200	0.290	0.450	0.008	0.011	0.018
<b>L1</b>	TBD	TBD	TBD	TBD	TBD	TBD
<b>L2</b>			0.125			0.005
<b>R</b>		0.075			0.003	
<b>r1</b>		0.075			0.003	
<b># per tube</b>	TBD					
<b># per tape and reel</b>	3000 pieces					
Controlling dimension: millimeters						

<sup>†</sup>This package is compliant with JEDEC standard MO-229, variation VCCC-3F with exception of the "D2" and "E2" dimensions as called out in the table above and the "r1" dimension which is not specified in the MO-229 standard.



**Package Dimensions for 3-Lead DFN**