

## MultiMedia Card EMI Filter Array with ESD Protection

### Features

- Three channels of EMI filtering, each with ESD protection
- Two channels of ESD protection
- Flow-through routing for MMC interface
- $\pm 15\text{kV}$  ESD protection (IEC 61000-4-2, contact discharge)
- $\pm 30\text{kV}$  ESD protection (HBM)
- Greater than 30dB of attenuation at 1GHz
- Chip Scale Package features extremely low lead inductance for optimum filter and ESD performance
- 10-bump, 1.998mm x 1.458mm footprint Chip Scale Package (CSP)
- Available with *OptiGuard™* coating for improved reliability
- Lead-free version available

### Applications

- MultiMedia Card (MMC) slot in mobile handsets and other handheld devices such as digital cameras and MP3 players
- I/O port protection for mobile handsets, notebook computers, PDAs etc.
- EMI filtering for data ports in cell phones, PDAs or notebook computers

### Product Description

The CM1424 is an EMI filter array integrating 3 pi-filters (C-R-C) and 2 channels of ESD protection. The CM1424 has component values of 12pF - 100 $\Omega$  - 12pF. The parts include avalanche-type ESD diodes on every pin, which provide a very high level of protection for sensitive electronic components that may be subjected to electrostatic discharge (ESD). The ESD diodes connected to the filter ports safely dissipate ESD strikes of  $\pm 15\text{kV}$ , beyond the maximum requirement of the IEC61000-4-2 international standard. Using the MIL-STD-883 (Method 3015) specification for Human Body Model (HBM) ESD, the pins are protected for contact discharges at greater than  $\pm 30\text{kV}$ .

The ESD diodes on pins A2 and C2 safely dissipate ESD strikes of  $\pm 15\text{kV}$ , well beyond the maximum requirement of the IEC 61000-4-2 international standard.

This device is particularly well-suited for portable electronics (e.g. mobile handsets, PDAs, notebook computers) because of its small package and easy-to-use pin assignments. In particular, the CM1424 is ideal for EMI filtering and protecting data lines from ESD for the MultiMedia Card (MMC) slot in mobile handsets.

The CM1424 devices are optionally available with *OptiGuard™* coating which results in improved reliability. The CM1424 is available in space-saving, low-profile, chip-scale packages with optional lead-free finishing.

### Electrical Schematic

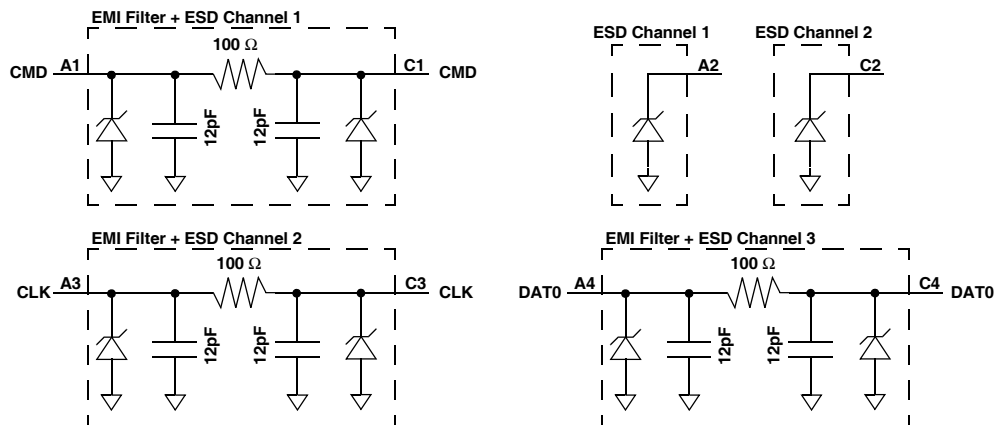

**PACKAGE / PINOUT DIAGRAMS**

CM1424 CSP Package (Uncoated)

 CM1424 CSP Package (*OptiGuard*<sup>™</sup> coated)

**Notes:**

- 1) These drawings are not to scale.
- 2) Lead-free devices are specified by using a "+" character for the top side orientation mark.

**PIN DESCRIPTIONS**

PIN(s)	NAME	DESCRIPTION	PIN(s)	NAME	DESCRIPTION
A1	EMI+ESD1	CMD Filter Channel 1	C1	EMI+ESD1	CMD Filter Channel 1
A2	ESD1	ESD Channel 1	C2	ESD2	ESD Channel 2
A3	EMI+ESD2	CLK Filter Channel 2	C3	EMI+ESD2	CLK Filter Channel 2
A4	EMI+ESD3	DAT0 Filter Channel 3	C4	EMI+ESD3	DAT0 Filter Channel 3
B1-B2	GND	Device Ground			

**Ordering Information**
**PART NUMBERING INFORMATION**

Bumps	PKG	Standard Finish				Lead-free Finish <sup>2</sup>			
		No Coating		<i>OptiGuard</i> <sup>™</sup> Coated		No Coating		<i>OptiGuard</i> <sup>™</sup> Coated	
		Ordering Part Number <sup>1</sup>	Part Marking	Ordering Part Number <sup>1</sup>	Part Marking	Ordering Part Number <sup>1</sup>	Part Marking	Ordering Part Number <sup>1</sup>	Part Marking
10	CSP	CM1424-01CS	N241	CM1424-03CS	N243	CM1424-01CP	N241	CM1424-03CP	N243

Note 1: Parts are shipped in Tape &amp; Reel form unless otherwise specified.

Note 2: Lead-free devices are specified by using a "+" character for the top side orientation mark.

## Specifications

### ABSOLUTE MAXIMUM RATINGS

PARAMETER	RATING	UNITS
Storage Temperature Range	-65 to +150	°C
DC Power per Resistor	100	mW
DC Package Power Rating	300	mW

### STANDARD OPERATING CONDITIONS

PARAMETER	RATING	UNITS
Operating Temperature Range	-40 to +85	°C

### ELECTRICAL OPERATING CHARACTERISTICS<sup>1</sup>

SYMBOL	PARAMETER	CONDITIONS	MIN	TYP	MAX	UNITS
R	Resistance		80	100	120	Ω
C	Capacitance	At 2.5V DC, 1MHz, 30mV AC	9	12	15	pF
V <sub>DIODE</sub>	Diode Standoff Voltage	I <sub>DIODE</sub> = 10μA		6.0		V
I <sub>LEAK</sub>	Diode Leakage Current (reverse bias)	V <sub>DIODE</sub> = +3.3V		100	300	nA
V <sub>SIG</sub>	Signal Clamp Voltage Positive Clamp Negative Clamp	I <sub>LOAD</sub> = 10mA	5.6 -1.5	6.8 -0.8	9.0 -0.4	V V
V <sub>ESD</sub>	In-system ESD Withstand Voltage a) Human Body Model, MIL-STD-883, Method 3015 b) Contact Discharge per IEC 61000-4-2 Level 4	Notes 2 and 3	±30 ±15			kV kV
R <sub>DYN</sub>	Dynamic Resistance Positive Negative			1.6 0.4		Ω Ω
f <sub>C</sub>	Cut-off Frequency Z <sub>SOURCE</sub> =50Ω, Z <sub>LOAD</sub> =50Ω	Channel R=100Ω, Channel C=12pF		157		MHz

Note 1: T<sub>A</sub>=25°C unless otherwise specified.

Note 2: ESD applied to input and output pins with respect to GND, one at a time.

Note 3: These parameters are guaranteed by design and characterization.

## Performance Information

Typical Filter Performance ( $T_A=25^\circ\text{C}$ , DC Bias=0V, 50 Ohm Environment)

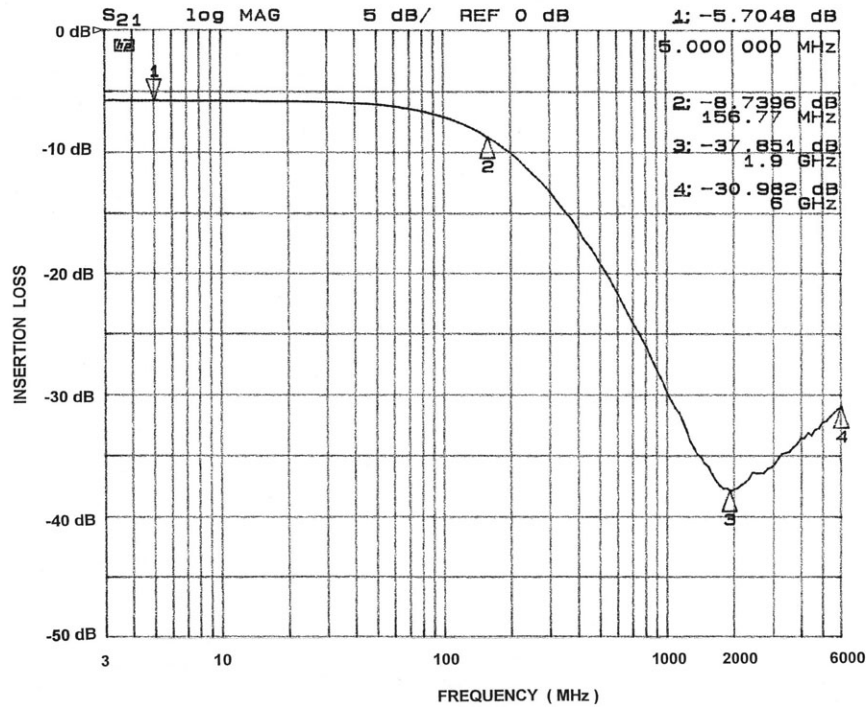

Figure 1. Insertion Loss VS. Frequency (A1-C1 to GND B1)

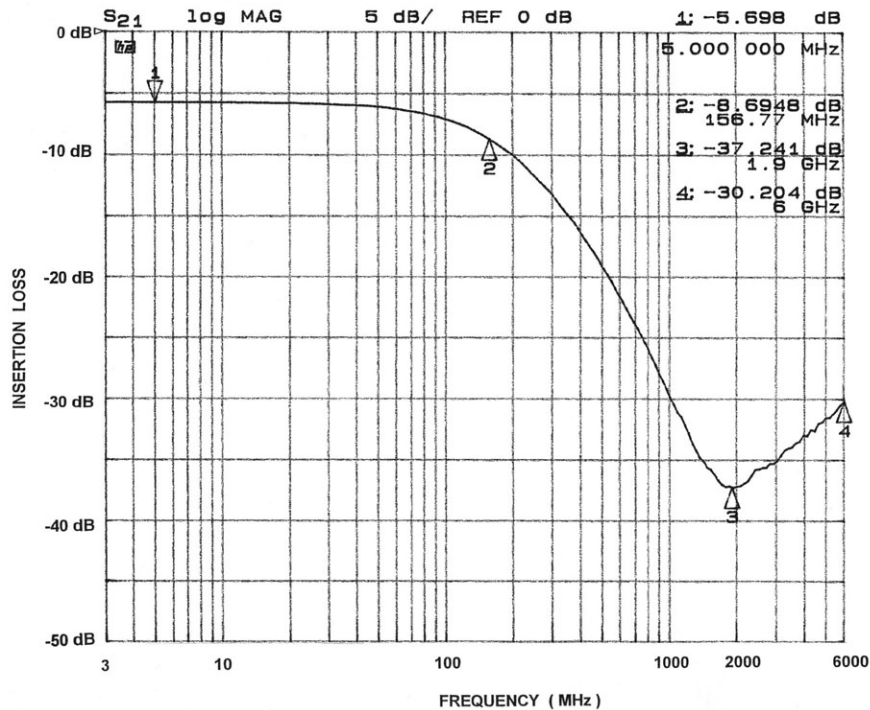
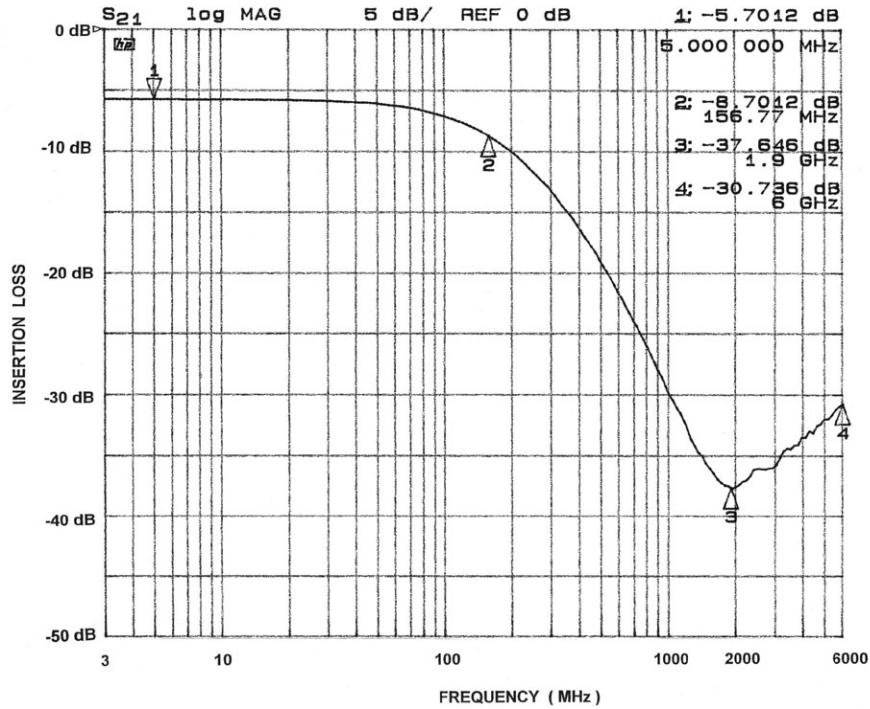

Figure 2. Insertion Loss VS. Frequency (A3-C3 to GND B2)

**Performance Information (cont'd)**

Typical Filter Performance (T<sub>A</sub>=25°C, DC Bias=0V, 50 Ohm Environment)



**Figure 3. Insertion Loss VS. Frequency (A4-C4 to GND B2)**

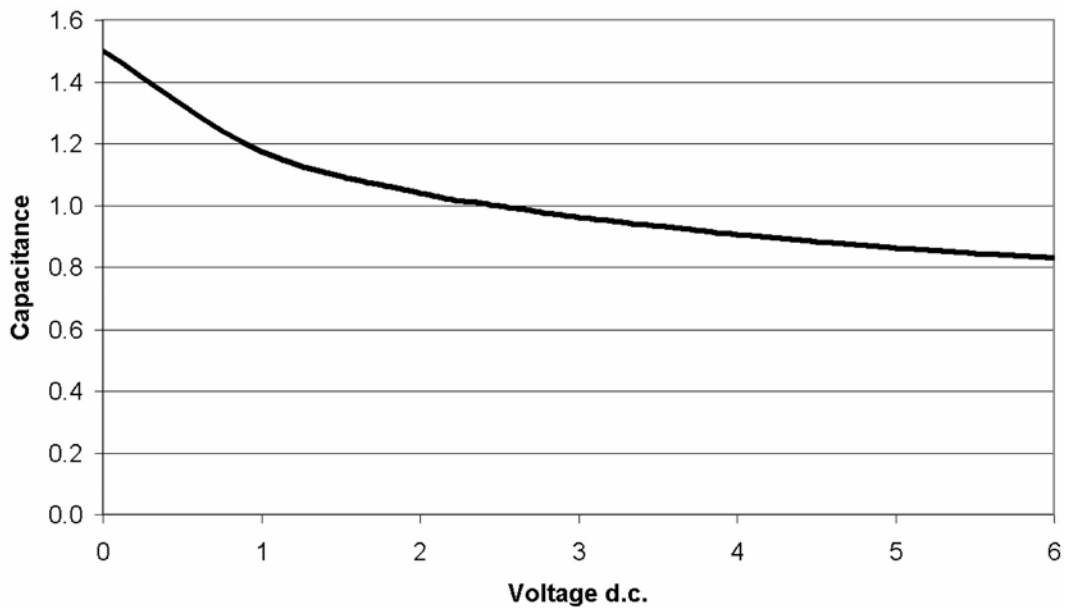

**Figure 4. Filter Capacitance vs. Input Voltage over Temperature (normalized to capacitance at 2.5VDC and 25°C)**

## Application Information

Refer to Application Note AP-217, "The Chip Scale Package", for a detailed description of Chip Scale Packages offered by California Micro Devices.

### PRINTED CIRCUIT BOARD RECOMMENDATIONS

PARAMETER	VALUE
Pad Size on PCB	0.275mm
Pad Shape	Round
Pad Definition	Non-Solder Mask defined pads
Solder Mask Opening	0.325mm Round
Solder Stencil Thickness	0.125mm - 0.150mm
Solder Stencil Aperture Opening (laser cut, 5% tapered walls)	0.330mm Round
Solder Flux Ratio	50/50 by volume
Solder Paste Type	No Clean
Pad Protective Finish	OSP (Entek Cu Plus 106A)
Tolerance — Edge To Corner Ball	±50µm
Solder Ball Side Coplanarity	±20µm
Maximum Dwell Time Above Liquidous (183°C)	60 seconds
Maximum Soldering Temperature for a Eutectic Device using Eutectic Solder Paste	240°C
Maximum Soldering Temperature for a Lead-free Device using Lead-free Solder Paste	260°C

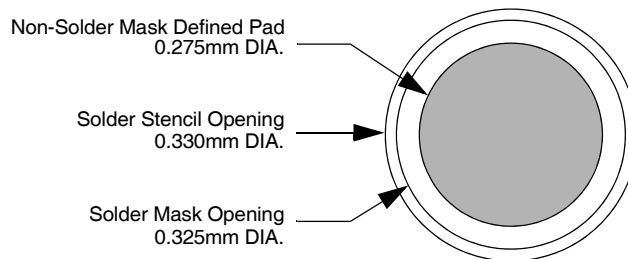

**Figure 5. Recommended Non-Solder Mask Defined Pad Illustration**

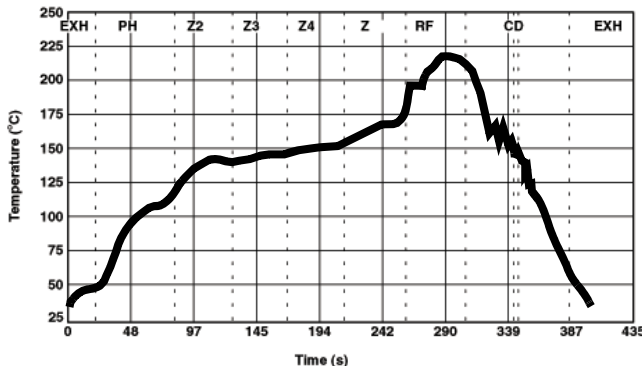

**Figure 6. Eutectic (SnPb) Solder Ball Reflow Profile**

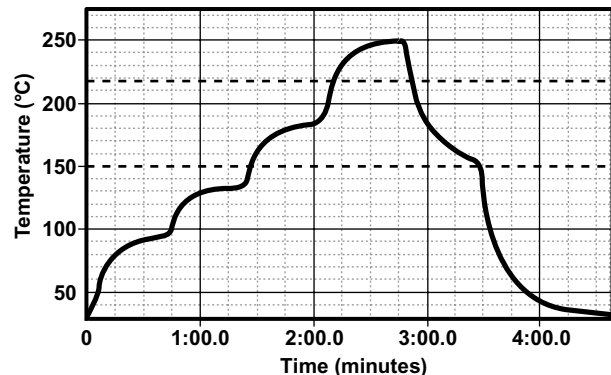

**Figure 7. Lead-free (SnAgCu) Solder Ball Reflow Profile**

### Mechanical Details (cont'd)

CM1424 devices are supplied in custom Chip Scale Packages (CSP) and are available with optional *OptiGuard™* coating.

#### CM1424 Mechanical Specifications

The package dimensions for the CM1424 are presented below.

PACKAGE DIMENSIONS						
Package	Custom CSP					
Bumps	10					
Dim	Millimeters			Inches		
	Min	Nom	Max	Min	Nom	Max
A1	1.953	1.998	2.043	0.0769	0.0787	0.0804
A2	1.413	1.458	1.503	0.0556	0.0574	0.0592
B1	0.495	0.500	0.505	0.0195	0.0197	0.0199
B2	0.245	0.250	0.255	0.0096	0.0098	0.0100
B3	0.430	0.435	0.440	0.0169	0.0171	0.0173
B4	0.430	0.435	0.440	0.0169	0.0171	0.0173
C1	0.199	0.249	0.299	0.0078	0.0098	0.0118
C2	0.244	0.294	0.344	0.0096	0.0116	0.0135
D1 <sup>1</sup>	0.562	0.606	0.650	0.0221	0.0239	0.0256
D2 <sup>1</sup>	0.356	0.381	0.406	0.0140	0.0150	0.0160
D3 <sup>2</sup>	0.575	0.644	0.714	0.0226	0.0254	0.0281
D4 <sup>2</sup>	0.368	0.419	0.470	0.0145	0.0165	0.0185
# per tape and reel	3500 pieces					
Controlling dimension: millimeters						

Note 1: Applies to uncoated devices only.  
 Note 2: Applies to *OptiGuard™* (coated) devices only.

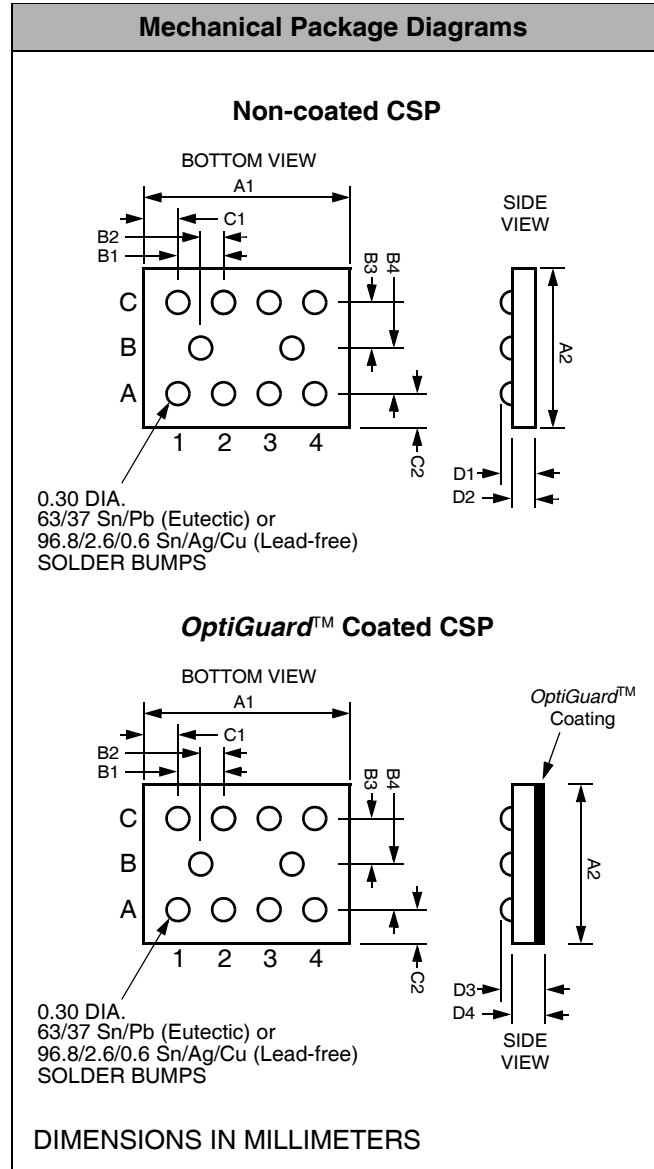

**Package Dimensions for  
 CM1424 Chip Scale Package**

## Mechanical Details (cont'd)

### CSP Tape and Reel Specifications

PART NUMBER	CHIP SIZE (mm)	POCKET SIZE (mm) $B_0 \times A_0 \times K_0$	TAPE WIDTH W	REEL DIAMETER	QTY PER REEL	$P_0$	$P_1$
CM1424-01	1.998x 1.458 x 0.606	2.29 x 1.6 x 0.81	8mm	178mm (7")	3500	4mm	4mm
CM1424-03	1.998 x 1.458 x 0.644	2.29 x 1.6 x 0.81	8mm	178mm (7")	3500	4mm	4mm

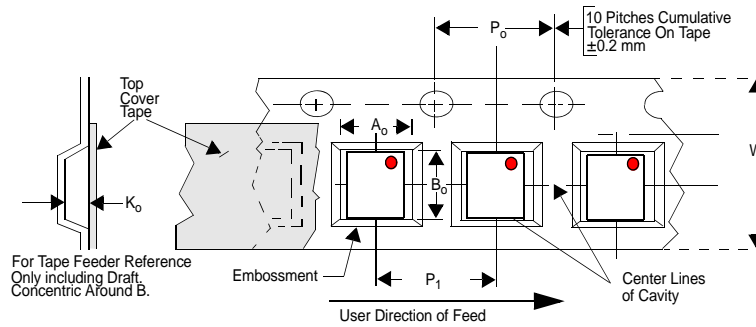

**Figure 8. Tape and Reel Mechanical Data**