

GENERAL DESCRIPTION

The CM2026A is a dual integrated high-side power switch with independent enable and flag functions, optimized for self-powered and bus-powered Universal Serial Bus (USB) applications. Few external components are necessary to satisfy USB requirements.

The CM2026A satisfies the following USB requirements: each switch channel supplies up to 500mA as required by USB downstream devices; the switch's low on-resistance meets USB voltage drop requirements; fault current is limited to typically 1000mA, well below the UL 25VA safety requirements; and a flag output is available to indicate fault conditions to the local USB controller. Soft start eliminates the momentary voltage drop on the upstream port that may occur when the switch is enabled in bus-powered applications. Additional features include thermal shutdown to prevent catastrophic switch failure from high-current loads, undervoltage lockout (UVLO) to ensure that the device remains off unless there is a valid input voltage present, and 3.3V and 5V logic compatible enable inputs.

The CM2026A is available in active-high version in 8-pin DIP and SOIC packages.

FEATURES

- ◆ Compliant to USB specifications
- ◆ UL Recognized Component
- ◆ 2 independent switches
- ◆ 2.7V to 5.5V input voltage
- ◆ 500mA minimum continuous load current per port
- ◆ 110mΩ maximum on-resistance
- ◆ 1.25A maximum short circuit current limit
- ◆ Individual open-drain fault flag pins
- ◆ 110uA typical on-state supply current
- ◆ 1uA typical off-state supply current
- ◆ Output can be forced higher than input (off-state)
- ◆ Thermal shutdown
- ◆ 2.4V typical undervoltage lockout (UVLO)
- ◆ 1ms turn-on (soft-start) and fast turnoff
- ◆ Active-high enable version
- ◆ 8-pin SOIC and DIP packages

APPLICATIONS

- ◆ USB host and self-powered hubs
- ◆ USB bus-powered hubs
- ◆ Hot plug-in power supplies
- ◆ Battery-charger circuit

PIN CONFIGURATION

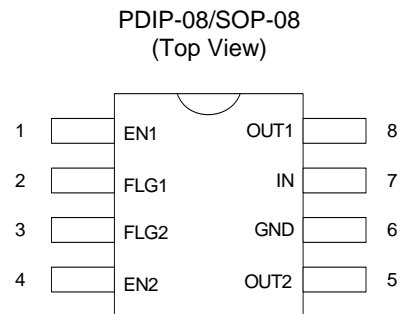

TEST CIRCUIT

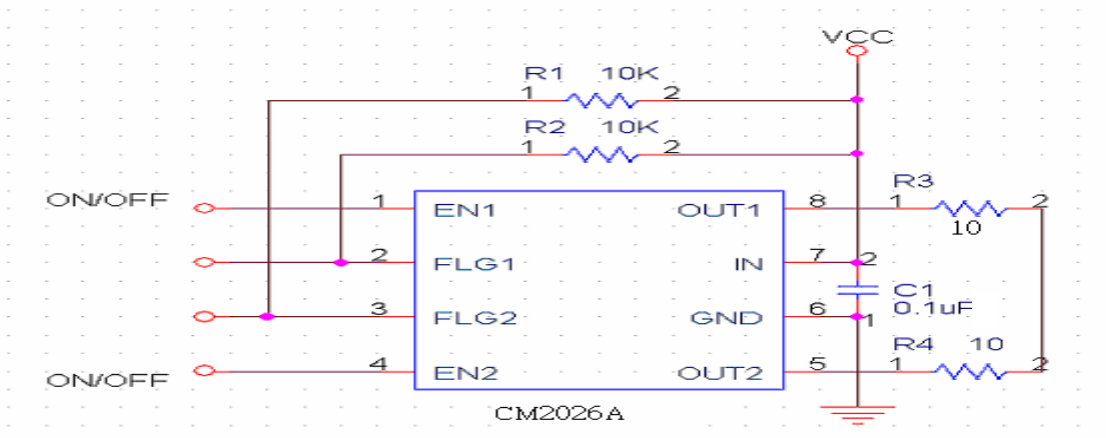

PIN DESCRIPTION

Pin No.	Symbol	Description
1,4	EN(1/2)	Enable (Input): Logic-compatible enable input. (H: Active High , L: Active Low). Do not float.
2,3	FLG(1/2)	Fault Flag (Output): open-drain output. Indicates overcurrent, UVLO, and thermal shutdown.
6	GND	Ground: Supply return.
7	IN	Supply Input: Output MOSFET drain. Also supplies IC's internal circuitry. Connect to positive supply.
8,5	OUT(1/2)	Switch Output: Output MOSFET source. Typically connect to switched side of load.

BLOCK DIAGRAM

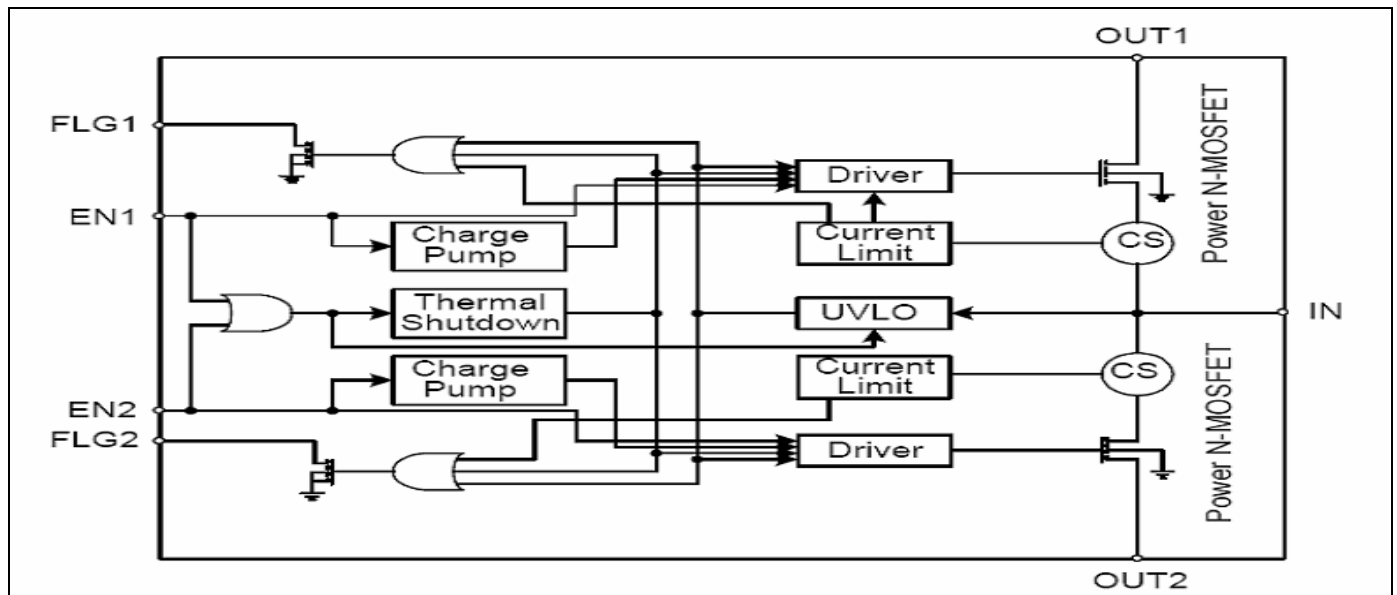

ORDERING INFORMATION

Part Number	Enable	Temperature Range	Package
CM2026AGHIS	Active High	-40°C to +85°C	8-Pin SOIC (S08)
CM2026AGLIS	Active Low	-40°C to +85°C	8-Pin SOIC (S08)

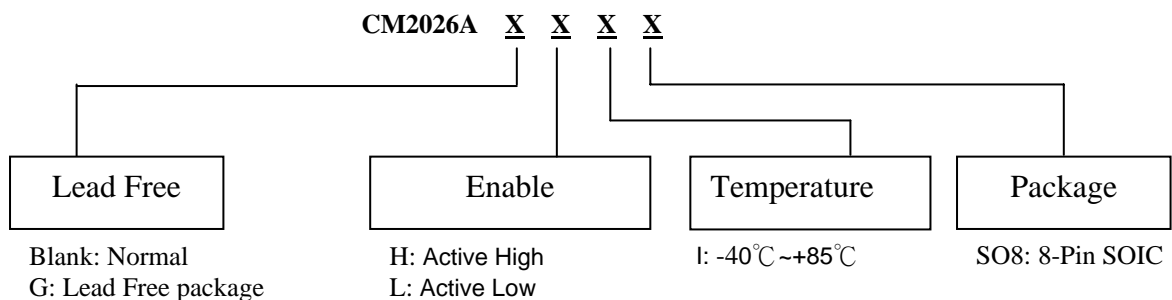

ABSOLUTE MAXIMUM RATINGS (Note 1) OPERATING RATINGS (Note 2)

Supply Voltage (V_{IN}) +7V
 Fault Flag Voltage (V_{FLG}) +7V
 Fault Flag Current (I_{FLG}) 50mA
 Output Voltage (V_{OUT}) +7V
 Output Current (I_{OUT}) Internally Limited
 Control Input (V_{EN}) -0.3V to 12V
 Storage Temperature (T_S) -65°C to +150°C
 Lead Temperature (Soldering 5 sec.) 260°C
 ESD Rating, **Note 3** 4kV

Supply Voltage (V_{IN}) +2.7V to +5.5V
 Ambient Operating Temperature (T_A) -40°C to +85°C
 Thermal Resistance
 SOIC (θ_{JA}) 120°C/W
 DIP (θ_{JA}) 100°C/W

ELECTRICAL CHARACTERISTICS

$V_{IN} = +5V$; $T_A = +25^\circ C$; unless noted

Parameter	Test Conditions	CM2026A			Unit
		Min.	Typ.	Max.	
Supply Current	Note 4 , switch off, OUT = open		0.50	5	μA
	Note 4 , all switches on, OUT = open		110	160	μA
Enable Input Threshold	Low-to-high transition	$V_{IN} = 3.3V$	1.7		V
		$V_{IN} = 5V$	3.5		
	High-to-low transition, Note4	$V_{IN} = 3.3V$	1.7		V
		$V_{IN} = 5V$	3.3		
Enable input Current	$V_{EN} = 0V$ to 5.5V	-1	± 0.01	1	μA
Enable Input Capacitance			1		PF
Switch Resistance	$V_{IN} = 5V$, $I_{OUT} = 500mA$, each switch		100	140	m Ω
	$V_{IN} = 3.3V$, $I_{OUT} = 500mA$, each switch		140	180	m Ω
Output Turn-On Delay	$R_L = 10\Omega$ each output		30		μs
Output Turn-On Rise Time	$R_L = 10\Omega$ each output		1		ms
Output Turn-Off Delay	$R_L = 10\Omega$ each output		0.5	10	μs
Output Turn-Off Fall Time	$R_L = 10\Omega$ each output		0.5	10	μs
Output Leakage Current	Each output (output disabled)			10	μA
Continuous Load Current	Each output	0.6			A
Short-Circuit Current Limit	Each output (enable into load), $V_{OUT} = 4.0V$	0.8	1.0	1.25	A
Current-Limit Threshold	Ramped load applied to enabled output, $V_{OUT} \leq 4.0V$, Note 5	1.0	1.2	1.4	A
Overtemperature Shutdown Threshold	T_J increasing		140		$^\circ C$
	T_J decreasing		130		$^\circ C$
Error Flag Output Resistance	$V_{IN} = 5V$, $I_L = 10mA$		10	25	Ω
	$V_{IN} = 3.3V$, $I_L = 10mA$		15	40	Ω
Error Flag Off Current	$V_{FLG} = 5V$		0.01	1	μA
UVLO Threshold	$V_{IN} =$ increasing		2.5		V
	$V_{IN} =$ decreasing		2.3		V

Note 1. Exceeding the absolute maximum rating may damage the device.

Note 2. The device is not guaranteed to function outside its operating rating.

Note 3. Devices are ESD sensitive. Handling precautions recommended. Human body model, 1.5k in series with 100pF.

Note 4. Off is $\leq 0.8V$ and on is $\geq 2.4V$. The enable input has approximately 200mV of hysteresis. See control threshold charts.

Note 5. See "Functional Characteristics: Current-Limit Response" photo.

PERFORMANCE CHARACTERISTICS

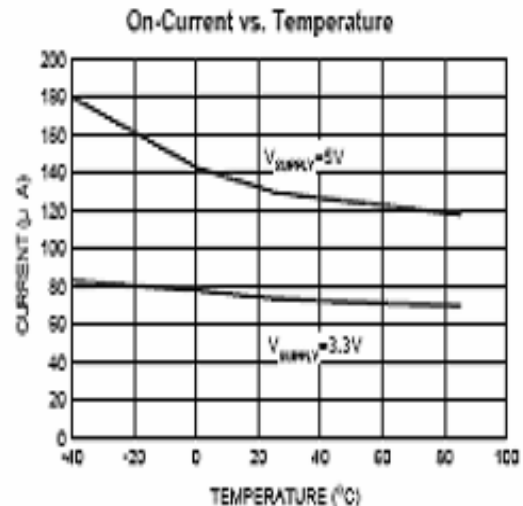
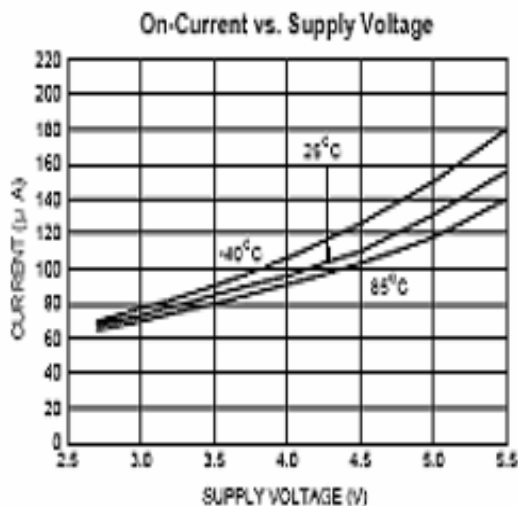
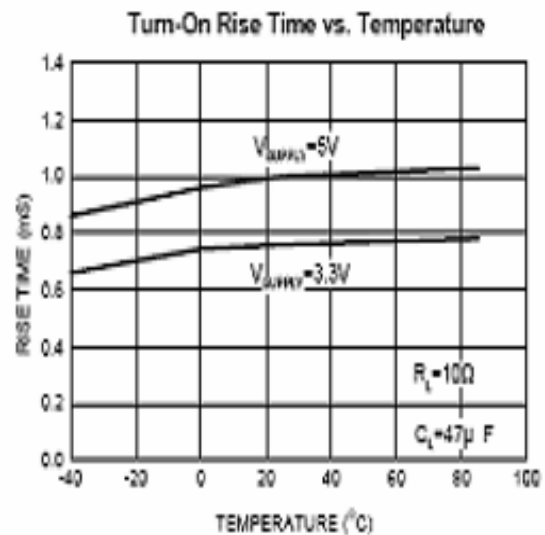
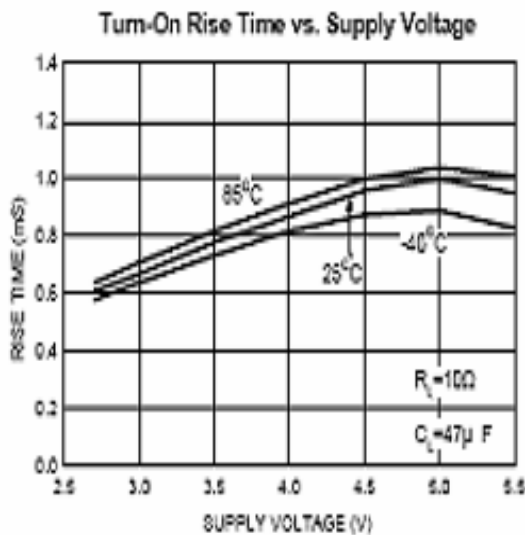
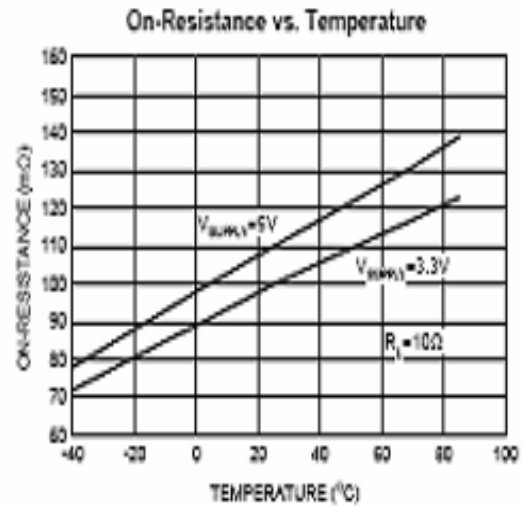
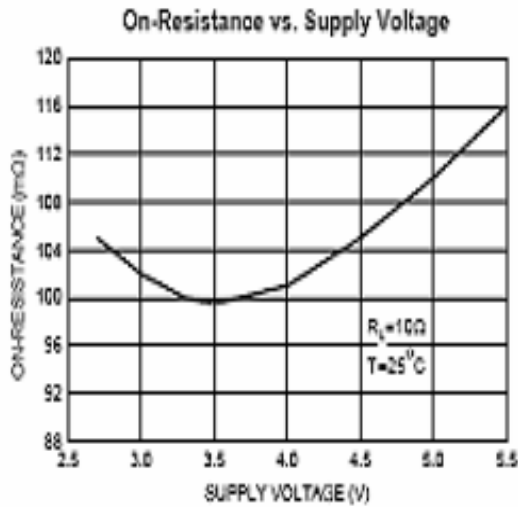

Off-Current vs. Supply Voltage

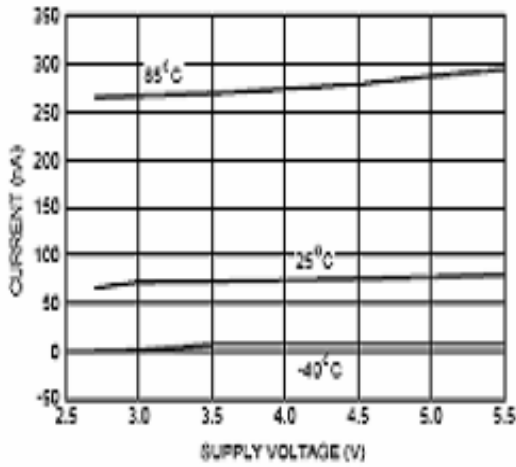

Off-Current vs. Temperature

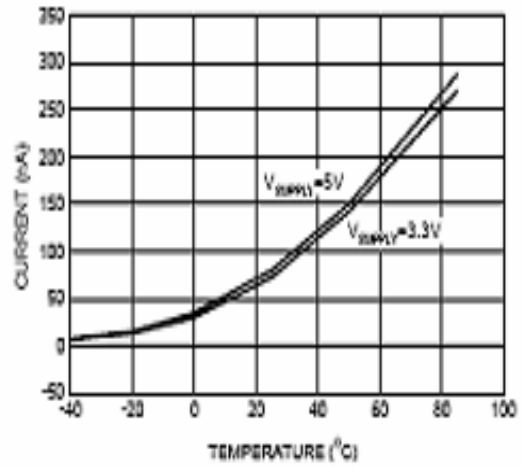

Enable Threshold vs. Supply Voltage

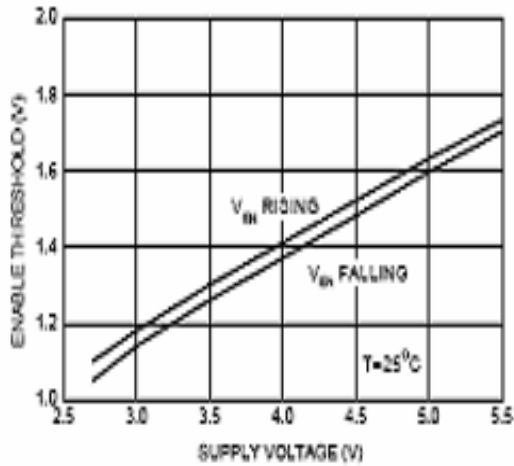

Enable Threshold vs. Temperature

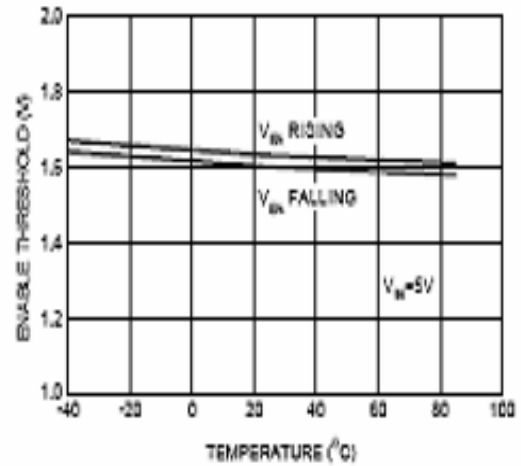

Short-Circuit Current-Limit vs. Supply Voltage

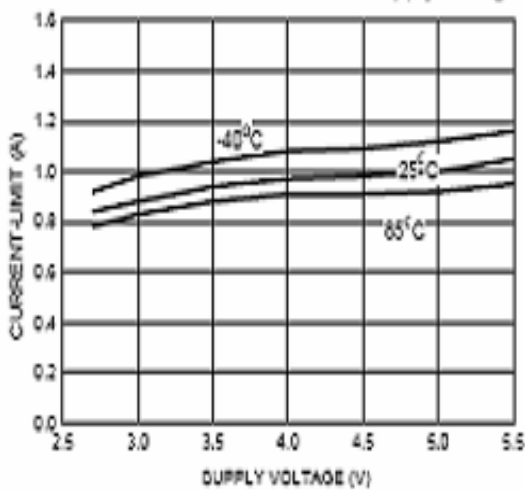

Short-Circuit Current-Limit vs. Temperature

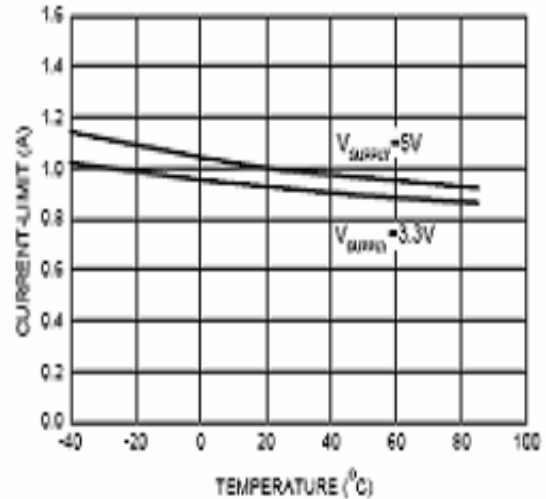

Current-Limit Threshold vs. Supply Voltage

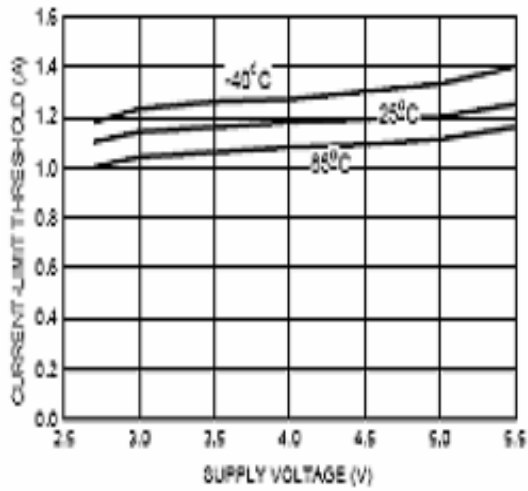

Current-Limit Threshold vs. Temperature

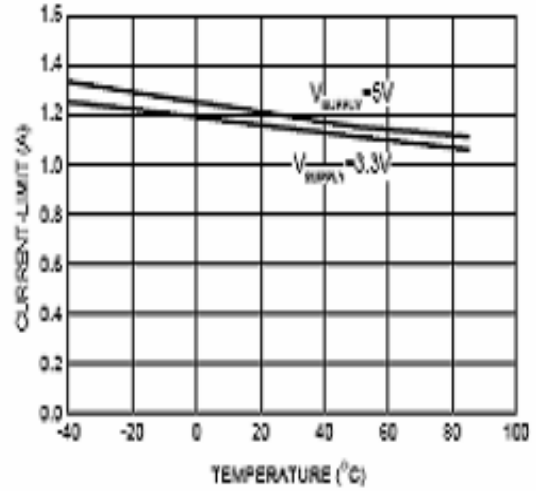

UVLO Threshold vs. Temperature

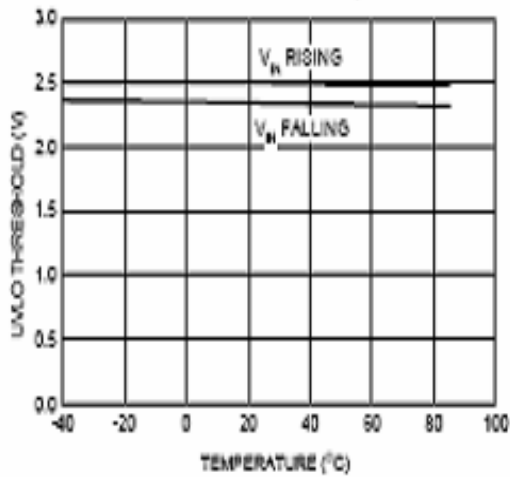

FUNCTIONAL CHARACTERISTICS

Turn-On/Turn-Off

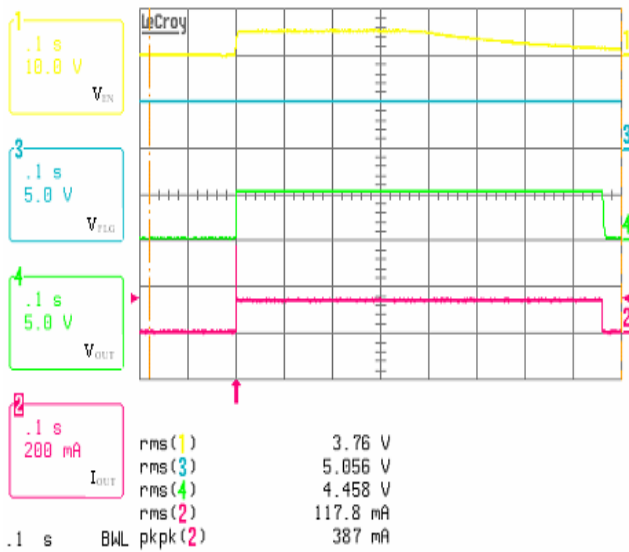

Turn-On

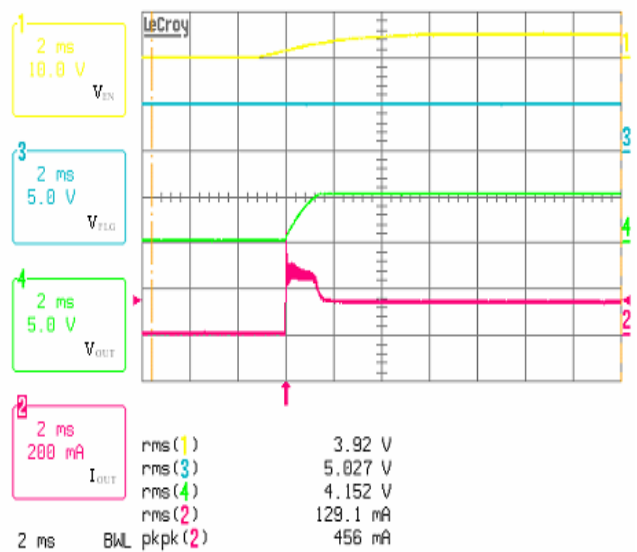

Turn-Off

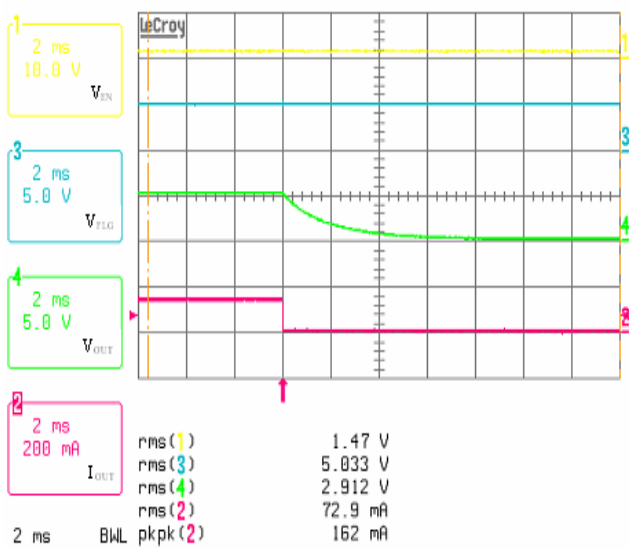

Enable Into Short

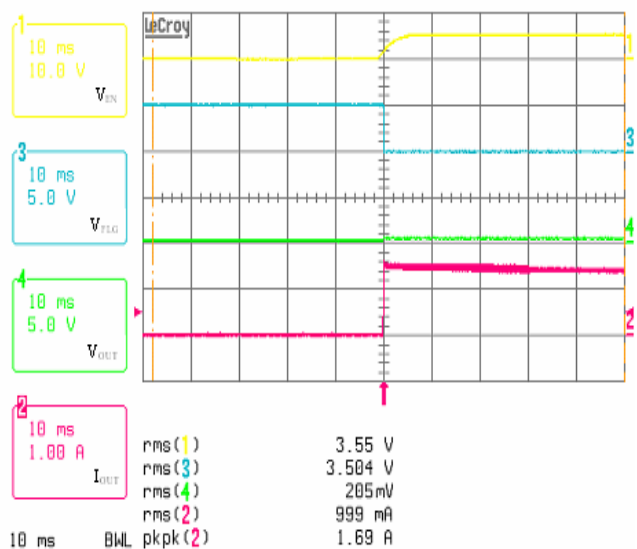

Current Limit

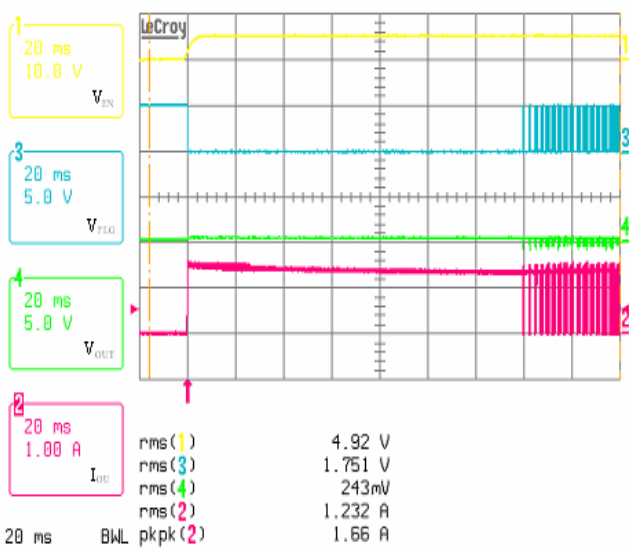

Current Limit

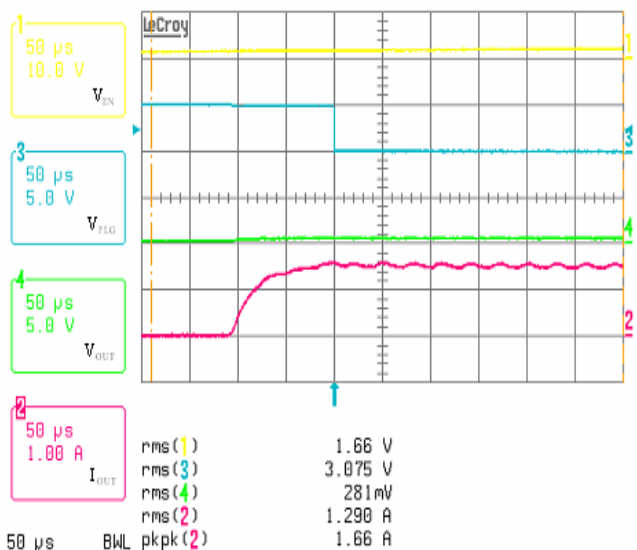

FUNCTIONAL DESCRIPTION

The CM2026A is dual high-side switch with active-high enable inputs, respectively. Fault conditions turn off or inhibit turn-on of one or more of the output transistors, depending upon the type of fault, and activate the open-drain error flag transistors making them sink current to ground.

Input and Output

IN (input) is the power supply connection to the logic circuitry and the drain of the output MOSFET. OUTx (output) is the source of its respective MOSFET. In a typical circuit, current flows through the switch from IN to OUT toward the load. If V_{OUT} is greater than V_{IN} when a switch is enabled, current will flow from OUT to IN since the MOSFET is bi-directional when on.

The output MOSFET and driver circuitry are also designed to allow the MOSFET source to be externally forced to a higher voltage than drain ($V_{OUT} > V_{IN}$) when the output is off. In this situation, the CM2026A avoids undesirable current flow from OUT to IN. If $V_{IN} < 2.5V$, UVLO disables both switches.

Thermal Shutdown

Thermal shutdown shuts off the affected output MOSFETs and signals all fault flags if the die temperature exceeds 140 °C. 10 °C of hysteresis prevents the switch from turning on until the die temperature drops to 130 °C. Overtemperature detection functions only when at least one switch is enabled.

Current Limit Induced Thermal Shutdown

Internal circuitry increases the output MOSFET on-resistance until the series combination of the MOSFET on-resistance and the load impedance limit current to typically 1000mA. The increase in power dissipation, in most cases, will cause the CM2026A to go into thermal shutdown, disabling affected channels. When this is undesirable, thermal shutdown can be avoided by externally responding to the fault and disabling the current limited channel before the shutdown temperature is reached. The delay between the flag indication of a current limit fault and thermal shutdown will vary with ambient temperature, board layout, and load impedance, but is typically several hundred milliseconds. The USB controller must therefore recognize a fault and disable the appropriate channel with this time. If the fault is not removed or the switch is not disabled with the time, then the device will enter into a thermal oscillation of about 2Hz. This does not cause any damage to the device. Refer to "Functional Characteristics: Thermal Shutdown Response."

Undervoltage Lockout

UVLO (undervoltage lockout) prevents the output MOSFET from turning on until V_{IN} exceeds approximately 2.5V. In the undervoltage state, the FLAG will be low. After the switch turns on, if the voltage drops below approximately 2.3V, UVLO shuts off the output MOSFET and signals fault flag. Undervoltage detection functions only when at least one switch is enabled.

Current Sensing and Limiting

The current-limit threshold is preset internally. The preset level prevents damage to the output MOSFET and external load but allows a minimum current of 0.5A through the output MOSFET of each channel.

The current-limit circuit senses a portion of the output FET switch current. The current sense resistor shown in the block diagram is virtual and has no voltage drop. The reaction to an overcurrent condition varies with three scenarios:

Switch Enabled into Short Circuit

If a switch is powered on or enabled into a heavy load or short circuit, the switch immediately goes into a constant current mode, reducing the output voltage. The fault flag goes low until the load is reduced.

Short Circuit Applied to Output

When a heavy load is applied, a large transient current may flow until the current limit circuitry will respond. Once this occurs, the device limits current to less than the short-circuit current limit specification.

Current-Limit Response

The CM2026A current-limit profile exhibits a small foldback effect of approximately 500mA. Once this current-limit threshold is exceeded the device enters constant current mode.

Fault Flag

FLG is an N-channel, open-drain MOSFET output. The fault flag is active (low) for one or more of the following conditions: undervoltage (while $2V < V_{IN} < 2.7V$), current limit, or thermal shutdown. The flag output MOSFET is capable of sinking a 10mA load to typically 100mV above ground. Multiple FLG pins may be "wire NORed" to a common pull-up resistor.

APPLICATIONS INFORMATION

Supply Filtering

A 0.1 μ F to 1 μ F bypass capacitor from IN to GND, located at the device, is strongly recommended to control supply transients. Without a bypass capacitor, an output short may cause sufficient ringing on the input (from supply lead inductance) to damage internal control circuitry.

Input or output transients must not exceed the absolute maximum supply voltage ($V_{IN\ max} = 6V$) even for a short duration.

Enable Input

EN must be driven logic high or logic low for a clearly defined input. Floating the input may cause unpredictable operation. EN should not be allowed to go negative with respect to GND.

Soft Start

The CM2026A presents a high impedance when off, and slowly becomes a low impedance as it turns on. This reduces inrush current and related voltage drop that results from charging a capacitive load, satisfying the USB voltage droop requirements for bus-powered applications as shown in Figure 2.

The soft start circuit can be utilized to meet USB transient regulation specifications with large load capacitances ($C_{BULK} > 10\mu F$). The CM2026A will provide inrush current limiting for these applications.

Transient Overcurrent Filter

When the CM2026A is enabled, large values of capacitance at the output of the device will cause inrush current to exceed the short circuit current-limit threshold of the device and assert the flag. The duration of this time will depend on the size of the output capacitance. Refer to the "Functional Characteristics" turn-on and turnoff behaviors for details. During the capacitance charging time, the device enters into constant-current mode. As the capacitance is charged, the current decreases below the short circuit current-limit threshold old, and the flag will then be deserted.

In USB applications, it is required that output bulk capacitance is utilized to support hot-plug events. When the CM2026A is enabled, the flag may go active for about 1ms due to inrush current exceeding the current-limit setpoint. Additionally, during hot-plug events, inrush currents may also cause the flag to go active for 30 μ S. Since these conditions are not valid overcurrent faults, the USB controller must ignore the flag during these events. To prevent this erroneous overcurrent reporting, a 1ms RC filter as may be programmed into the USB logic controller, eliminating the need for the RC filter.

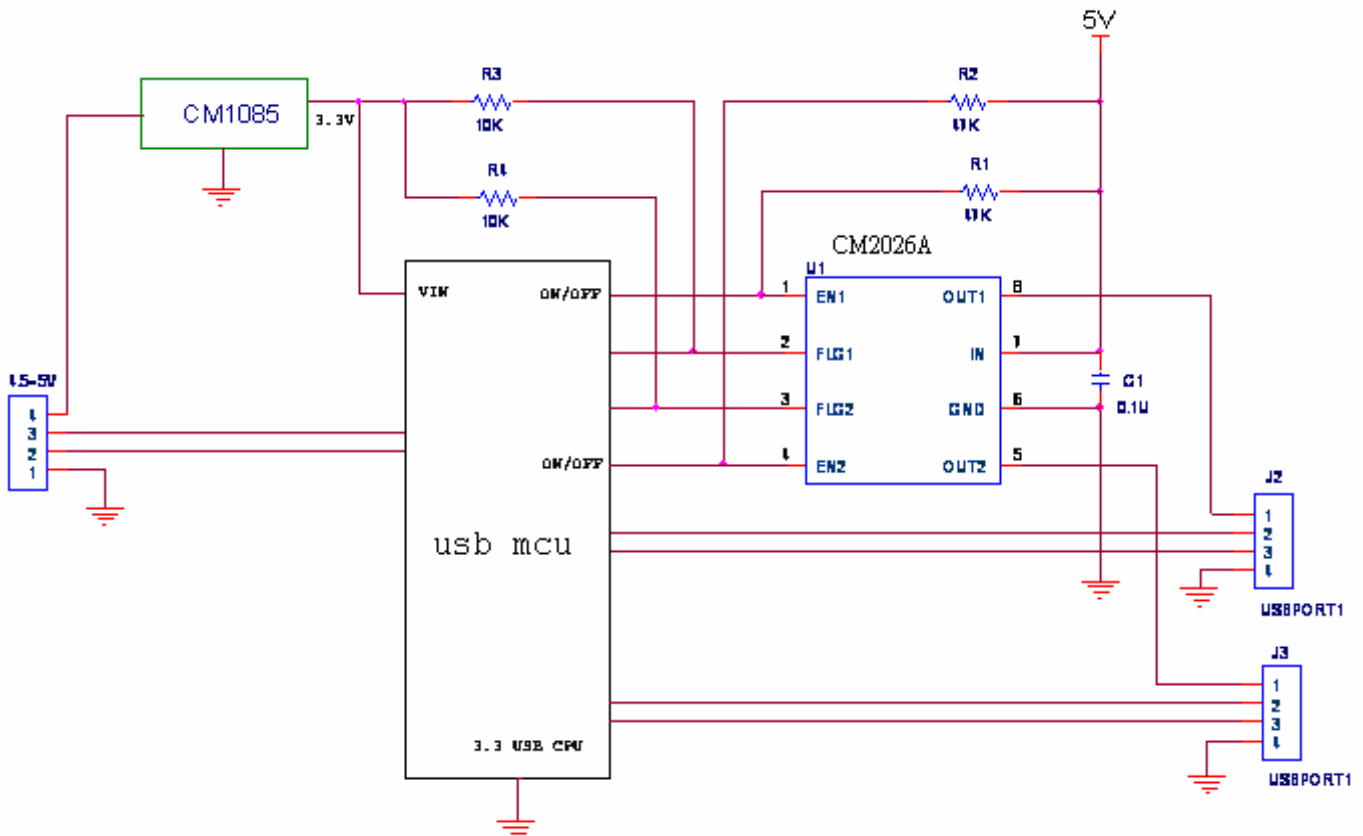

PACKAGE DIMENSION

8-PIN PDIP (P08)

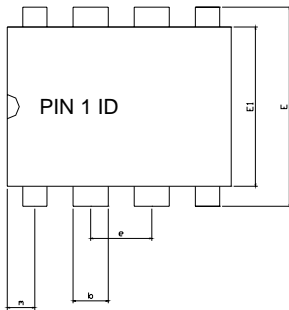

SYMBOLS	DIMENSIONS IN MILLIMETERS			DIMENSIONS IN INCHS		
	MIN	NOM	MAX	MIN	NOM	MAX
A	---	---	4.32	---	---	0.170
A1	0.38	---	---	0.015	---	---
b	1.40	---	1.65	0.055	---	0.065
b1	0.40	---	0.56	0.016	---	0.022
C	0.20	---	0.31	0.008	---	0.012
D	9.27	---	9.77	0.365	---	0.385
E	7.49	---	8.26	0.295	---	0.325
E1	6.09	---	6.61	0.240	---	0.260
e	---	2.54	---	---	0.100	---
L	3.18	---	---	0.125	---	---
m	0.50	---	---	0.02	---	---
θ	0°	---	15°	0°	---	15°

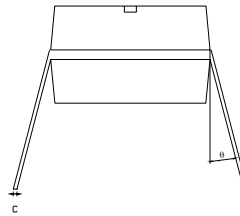
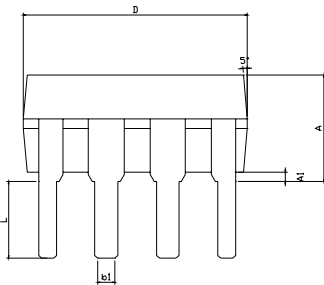

8-PIN SOP (S08)

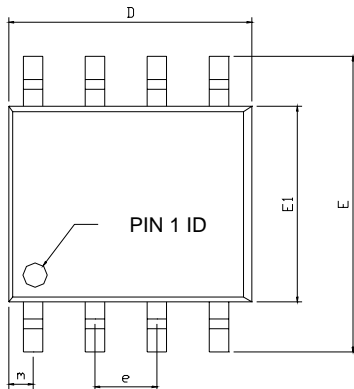

SYMBOLS	DIMENSIONS IN MILLIMETERS			DIMENSIONS IN INCHS		
	MIN	NOM	MAX	MIN	NOM	MAX
A1	0.10	---	0.25	0.004	---	0.010
A2	1.40	---	1.55	0.055	---	0.061
b	0.30	---	0.51	0.012	---	0.020
C	0.15	---	0.26	0.006	---	0.010
D	4.60	---	5.06	0.169	---	0.199
E	5.79	---	6.20	0.228	---	0.244
E1	3.76	---	4.01	0.148	---	0.158
e	---	1.27	---	---	0.050	---
L	0.38	---	0.69	0.015	---	0.035
m	0.43	---	0.69	0.017	---	0.027
θ	0°	---	8°	0°	---	8°

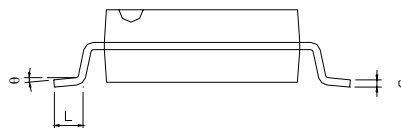
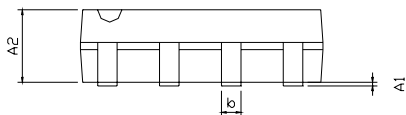

IMPORTANT NOTICE

Champion Microelectronic Corporation (CMC) reserves the right to make changes to its products or to discontinue any integrated circuit product or service without notice, and advises its customers to obtain the latest version of relevant information to verify, before placing orders, that the information being relied on is current.

A few applications using integrated circuit products may involve potential risks of death, personal injury, or severe property or environmental damage. CMC integrated circuit products are not designed, intended, authorized, or warranted to be suitable for use in life-support applications, devices or systems or other critical applications. Use of CMC products in such applications is understood to be fully at the risk of the customer. In order to minimize risks associated with the customer's applications, the customer should provide adequate design and operating safeguards.

HsinChu Headquarter

5F, No. 11, Park Avenue II,
Science-Based Industrial Park,
HsinChu City, Taiwan
TEL: +886-3-567 9979
FAX: +886-3-567 9909

Sales & Marketing

7F-6, No.32, Sec. 1, Chenggong Rd.,
Nangang District, Taipei City 115,
Taiwan R.O.C.
TEL: +886-2-2788 0558
FAX: +886-2-2788 2985
