

---

**GENERAL DESCRIPTION**

CM6901 is a SLS, SRC/LLC + SR resonant controller and it can operate at both SRC and LLC region with synchronous rectification to achieve high efficiency. Its unique features: FM + 2 PWMING modes. It is used for DC-DC conversion in offline application. Light load regulation is accomplished by transitioning the controller from frequency modulation mode into PWM mode. To have the optimal balance performance between hold-up time and efficiency, its frequency range crosses  $f_{r1}$ , resonant frequency.

CM6901 system has a constant voltage feedback loop with precision 2.5V Vfb reference. The 1V ILIMIT can be latched when a standby converter is applied; otherwise, it is an auto-restart I limit. The OVP protection can be latched when a standby converter is applied. Otherwise, the OVP protection is an auto-restart OVP.

**FEATURES**

- ◆ 90+ Controller
- ◆ Smaller and Thinner Transformer
- ◆ 20mS with reasonable Bulk Cap
- ◆ SLS, SRC/LLC + SR resonant controller
- ◆ Supply Voltage Range : 10V to 15V.
- ◆ Supply Voltage Range : 10V to 15V.
- ◆ 2 Gate Drivers: Typical Peak Drive from 12V supply : (PMOS~200 ohm and NMOS~100 ohm).
- ◆ UVLO=13V with 3V Hysteresis.
- ◆ Reference OK Comparator.
- ◆ FM + 2 PWMING Mode Operation
- ◆ Light Load PWMING
- ◆ SR Ideal Diode PWMING
- ◆ GM feao, FM modulation Error Amplifier
- ◆ GM deao, PWM Error Amplifier
- ◆ Close Loop Soft start Capability with Shutdown Function.
- ◆ Latch or Auto-Restart during Current Limit or OVP.
- ◆ Precision 2.5V Vfb threshold for constant voltage feedback loop
- ◆ Precision 1V I limit threshold
- ◆ Precision 2.75V OVP threshold

### APPLICATIONS

- ◆ DC-DC power supply.
- ◆ Operates in FM/PWM mode.

### CM6901G Pin Configuration

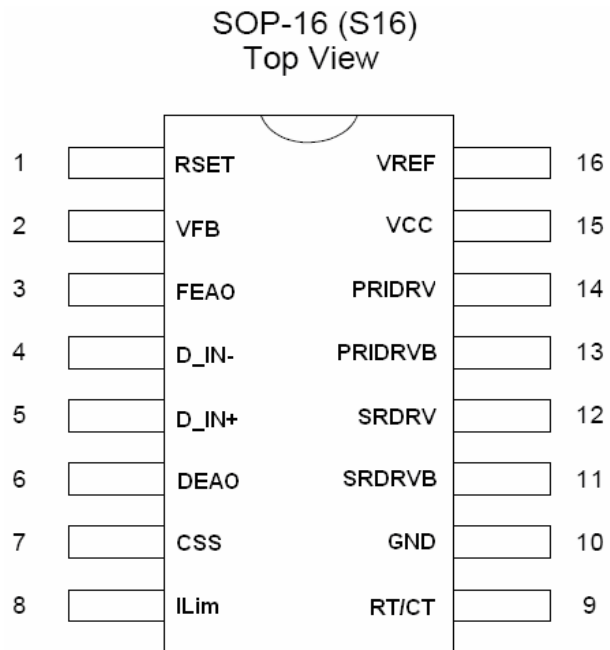

### ORDERING INFORMATION

Part Number	Temperature Range	Package
CM6901GIS	-40°C to 125°C	16-Pin SOIC (S016)

\*Note: G : Suffix for Pb Free Product

### TYPICAL APPLICATION CIRCUIT

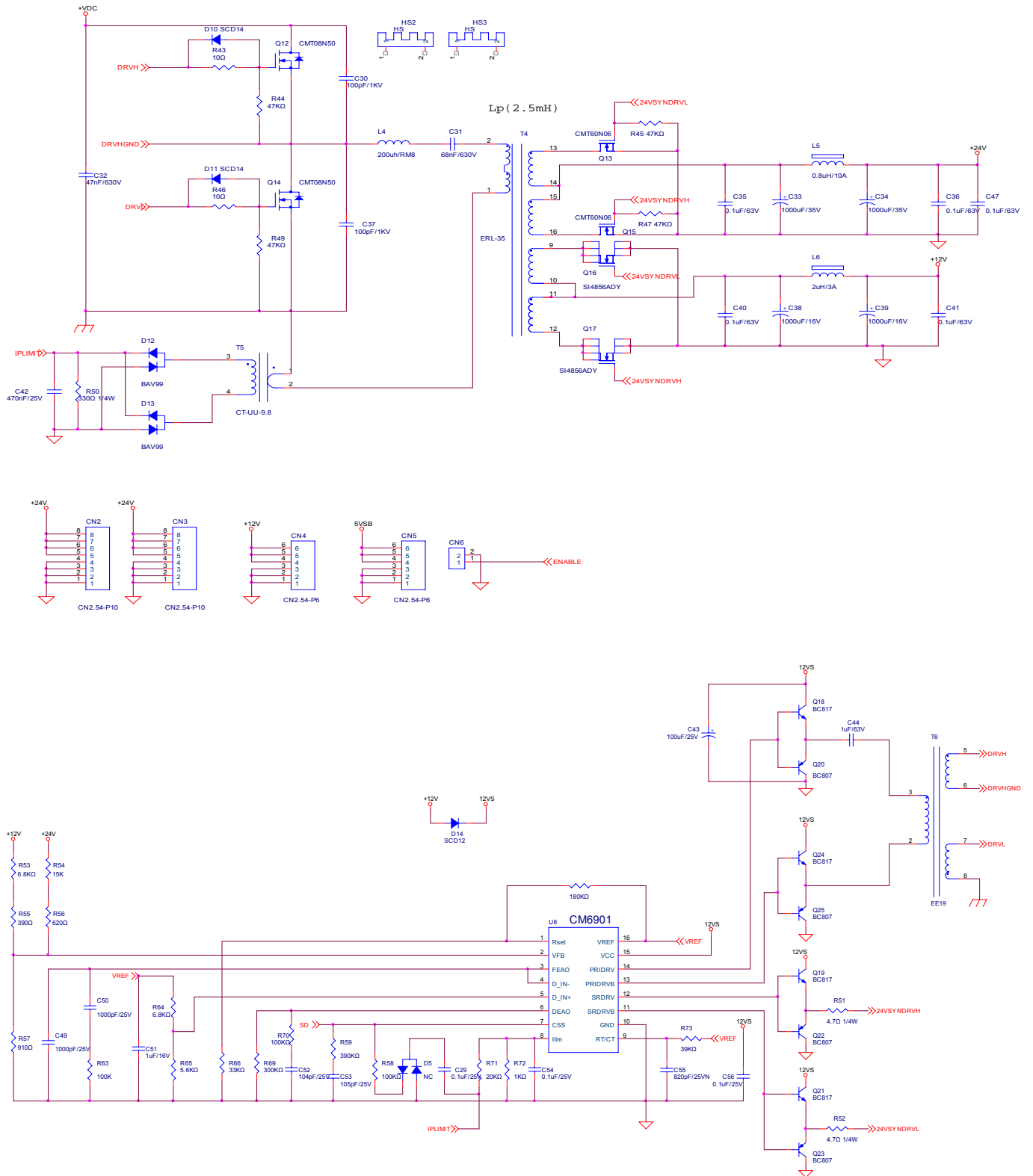

### PIN DESCRIPTION

Pin No.	Symbol	Description	Operating Voltage			
			Min.	Typ.	Max.	Unit
1	RSET	External resistor which convert FEAO voltage signal into current signal for frequency modulation.	0		5.5	V
2	VFB	Non-inverting input into resonant error amplifier and OVP input.	0	2.5	3	V
3	FEAO	Resonant error amplifier output and compensation node for frequency modulation control.	0		5.5	V
4	D_IN-	Inverting input into PWM error amplifier.	0		6	V
5	D_IN+	Non-inverting input into PWM error amplifier.	0		6	V
6	DEAO	PWM error amplifier output and compensation node for PWM control.	0		4.5	V
7	CSS	Soft start for FM/PWM operation with 1V enable threshold. Also, use for auto-restart operation during current limit.	0		5.5	V
8	ILIM	Input to current comparator with 1V threshold.	0	1	1.25	V
9	RTCT	Oscillator timing components which set the minimum frequency.	1.2		3	V
10	GND	Ground				
11	SDRVB	Synchronous MOSFET driver output.	-0.3		VCC	V
12	SDRV	Synchronous MOSFET driver output.	-0.3		VCC	V
13	PRIDRV	Primary side MOSFET driver output.	-0.3		VCC	V
14	PRIDRVB	Primary side MOSFET driver output.	-0.3		VCC	V
15	VCC	Positive supply for the IC	10	15	17.5	V
16	VREF	Buffered output for the 7.5V voltage reference		7.5		V

### BLOCK DIAGRAM

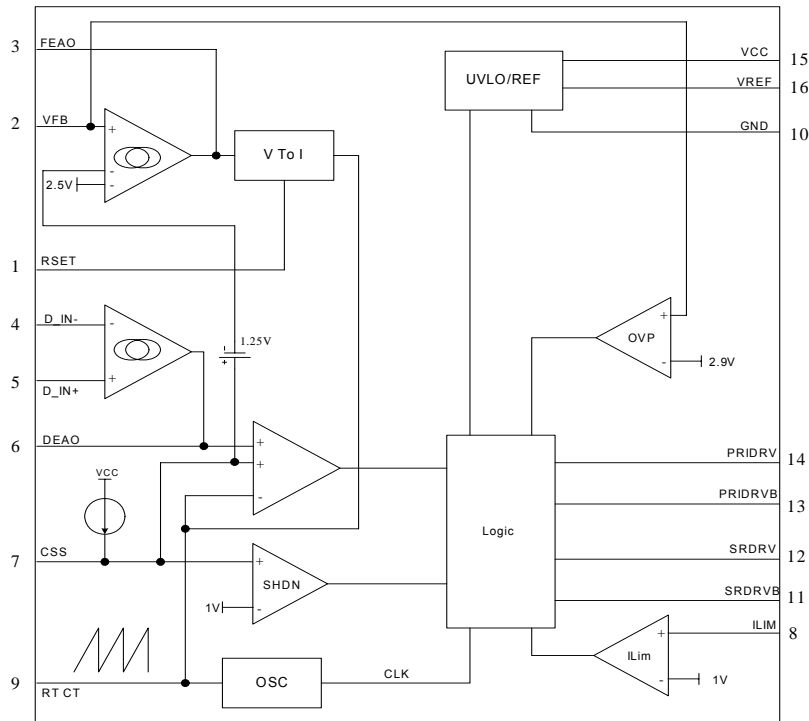

### ABSOLUTE MAXIMUM RATINGS (TA=25°C, unless otherwise specified.)

The following ratings designate persistent limits beyond which damage to the device may occur.

Symbol	Parameter	Value	Unit
VCC	DC Supply Voltage	-0.3 to 20	V
SRDRV	SRDRV Voltage	-0.3 to VCC+0.3	V
SRDRVB	SRDRVB Voltage	-0.3 to VCC+0.3	V
PRIDRV	PRIDRV Voltage	-0.3 to VCC+0.3	V
PRIDRVB	PRIDRVB Voltage	-0.3 to VCC+0.3	V
VREF	VREF Voltage	-0.3 to 7.5	V
RTCT	RTCT Voltage	-0.3 to VREF+0.3	V
VILIM	VILIM Voltage	-0.3 to VREF+0.3	V
CSS	CSS Voltage	-0.3 to VREF+0.3	V
DEAO	PWM Error Amplifier Output Voltage	-0.3 to VREF+0.3	V
D_IN+	Non-Inverting Input Into PWM Error Amplifier Voltage	-0.3 to VREF+0.3	V
FEAO	Resonant Error Amplifier Output Voltage	-0.3 to VREF+0.3	V
VFB	Non-Inverting Input Into Resonant Error Amplifier Voltage	-0.3 to VREF+0.3	V
RSET	V to I Voltage	-0.3 to VREF+0.3	V

### ELECTRICAL CHARACTERISTICS

(Vcc=12V, RTCT Freq. =100 KHz, Duty Cycle=50% , Temp=25 degree C, unless otherwise specified.)

Parameter	Symbol	Conditions	Min.	Typ.	Max.	Unit
<b>VREF</b> (pin 16)						
Reference Voltage	VREF	TA=25°C; Iref=1mA	7.4	7.5	7.6	V
Line Regulation		11V < Vcc < 16.5V		10	25	mV
Load Regulation		0mA < Iref < 7.5mA		10	25	mV
<b>VCC</b> (pin 15)						
VCC Start up voltage	Vstart		12.5	13	13.5	V
UVLO Hysteresics	Hyst			3	3.5	V
Operating Current	ICC			1		mA
<b>PRIDRV,PRIDRVB,SRDRV,SRDRV B</b> (pin 11,12,13 and 14)						
Output Low Voltage	Vol	I <sub>srdrv</sub> =-6mA		0.6	1.2	V
Output High Voltage	Voh	I <sub>srdrv</sub> =+6mA	9.6	10.8		V
Iout peak source current	Iout			0.12		A
Iout peak sink current	Iout			0.12		A
PMOS R <sub>dson</sub>	Rout			200.0	250.0	Ohm
NMOS R <sub>dson</sub>	Rout			100.0	150.0	Ohm
Dead Time between PRIDRV and PRIDRVB	T <sub>Dead</sub>			400		ns
Rising Edge Delay Between PRIDRV and SRDRV	T <sub>delay</sub>			500		ns
Falling Edge Delay Between SRDRV and PRIDRV	T <sub>delay</sub>			500		ns
Duty Cycle Range			0		50	%
<b>ILIM</b> (pin 8)						
Threshold Voltage	V <sub>th</sub>		0.9	1	1.1	V
<b>CSS</b> (pin 7)						
Soft Start Current	I <sub>ss</sub>			7.5		uA
Enable Voltage	V <sub>en</sub>		0.9	1.0	1.1	V
Enable Hysteresis	V <sub>hyst</sub>			75		mV
Auto-restart Upper Threshold	V <sub>up</sub>		4.85	5.0	5.15	V
Auto-restart Lower Threshold	V <sub>lw</sub>			1-V <sub>hyst</sub>		V

### ELECTRICAL CHARACTERISTICS

(Vcc=12V, RTCT Freq. =100 KHz, Duty Cycle=50% , Temp=25 degree C, unless otherwise specified.)

Parameter	Symbol	Conditions	Min.	Typ.	Max.	Unit
<b>FEAO Resonant Error Amplifier (pin 3)</b>						
Input Voltage Range					6	V
Transconductance	Gm			135		umho
Feedback Reference Voltage			2.45	2.5	2.55	V
Input Bias Current			-1	-0.5		uA
Output High Voltage				5.5+VBE		V
Output Low Voltage				0.1	0.4	V
Sink Current				-15		uA
Source Current				15		uA
Open Loop Gain				60		dB
<b>DEAO PWM Error Amplifier (pin 6)</b>						
Input Voltage Range					6	V
Transconductance	Gm			135		umho
Input Bias Current			-1.0	-0.5		uA
Output Voltage High				3+VBE		V
Output Voltage Low				0.1	0.4	V
Sink Current				-15		uA
Source Current				15		uA
Open Loop Gain				60		dB
<b>RTCT Oscillator;RT=61K;CT=470pF (pin 8)</b>						
Initial Accuracy		TA=25'C	95	100	105	Khz
Volatge Stability		11V < Vcc < 16.5V		1		%
Temperature Stability				2		%
Ramp Valley to Peak Voltage				2		V
CT Discharge Time				350		nS
Maxmum Duty cycle		DEAO > 3.0V		50		%
Minimum Duty Cycle		DEAO < 1.2V		0		%
<b>VFB OVP Comparator</b>						
Threshold Voltage				2.94		V
<b>VCC OVP Comparator</b>						
Input Voltage Range				17.5		V

## Timing Diagram

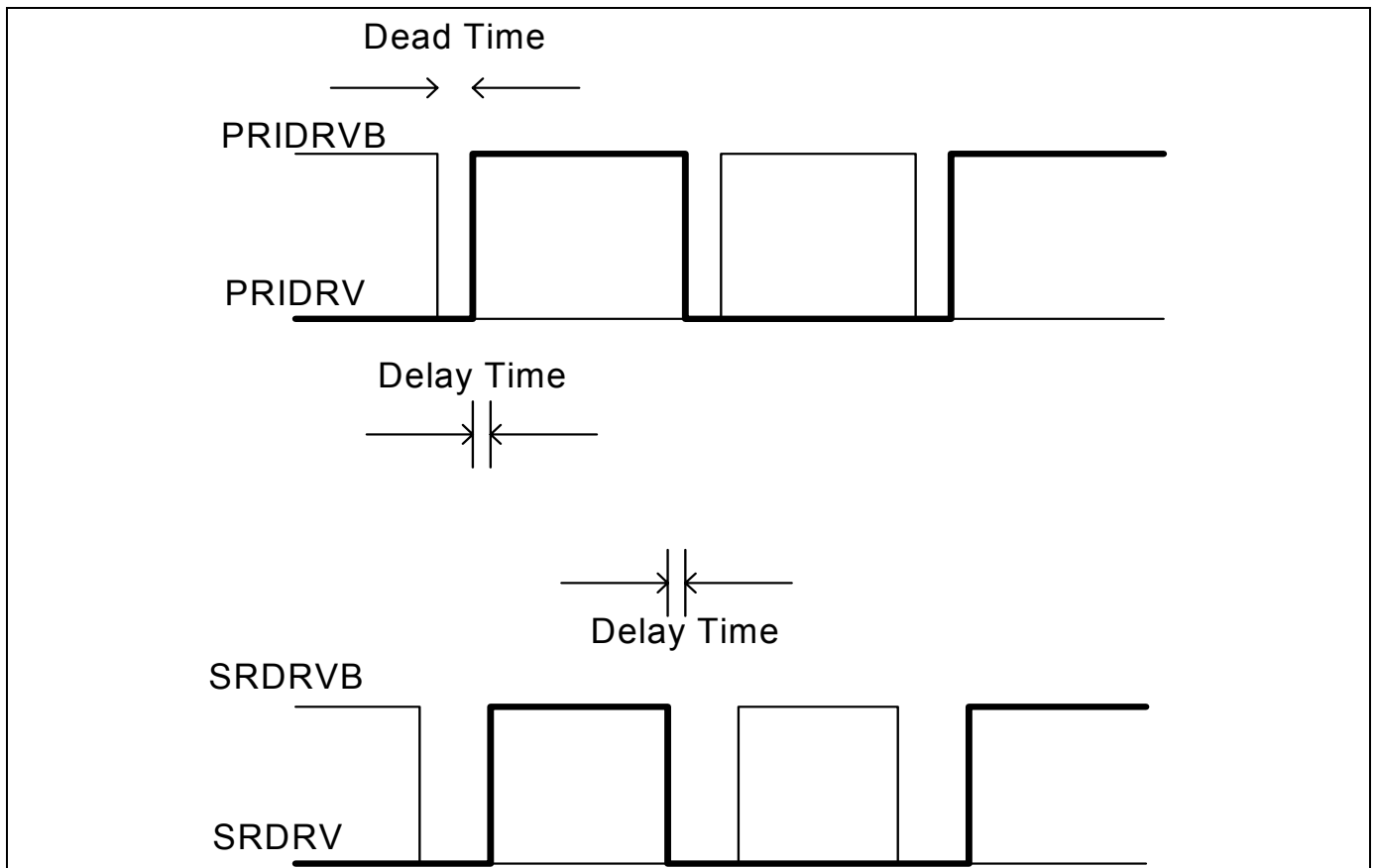

## Oscillator

The oscillator frequency is determined by the values of RT and CT.

$$f_{osc} = 1 / (t_{RAMP} + t_{DEADTIME})$$

$$t_{RAMP} = RT * CT * \ln((V_{REF} + I_{CHG} * RT - 1.25) / (V_{REF} + I_{CHG} * RT - 3)) \text{ where } I_{CHG} = 4 * (FEAO - V_{BE}) / R_{SET}$$

$$t_{DEADTIME} = 2.125V / 2.5mA * CT = 850 * CT$$

## Resonant Section

### FM Modulator

Frequency modulation of the resonant controller section is accomplished by controlling the charging current of the oscillator through resonant error amplifier. The frequency of the resonant section is  $\frac{1}{2}$  of the oscillator frequency. Compensation is accomplished by connecting R and C in series to the FEAO pin.

$$I_{CHG} = 4 * (FEAO - V_{BE}) / R_{SET}$$

$$I_{CHG(max)} = 20V / R_{SET}$$



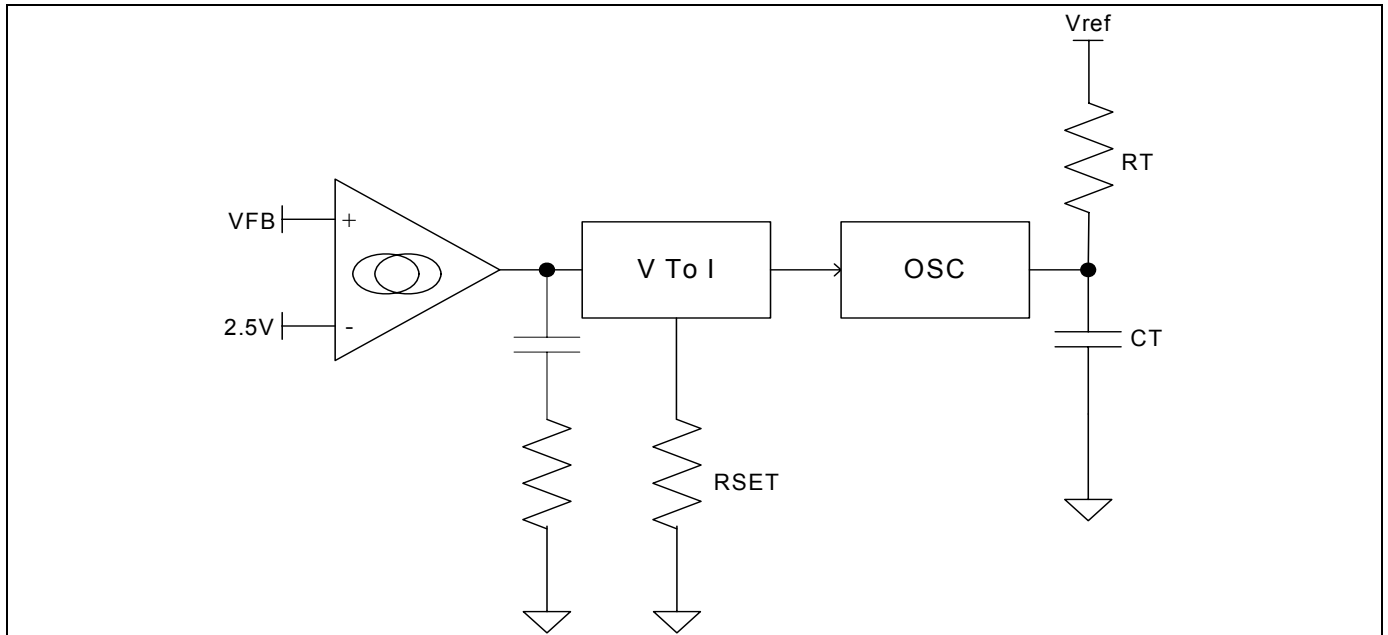

## 2 PWMings:

### SR Ideal Diode PWMing (Synchronous Outputs)

SR Ideal Diode PWMing for synchronous drivers is accomplished by comparing the voltage signal at the RSET pin to RTCT ramp. The pulse-width reduction happens when the voltage at the RSET is lower than 1.5V. This allows safe operation of the power converter with synchronous rectification when the switching frequency is below the highest resonant point frequency  $f_{r1}$ .

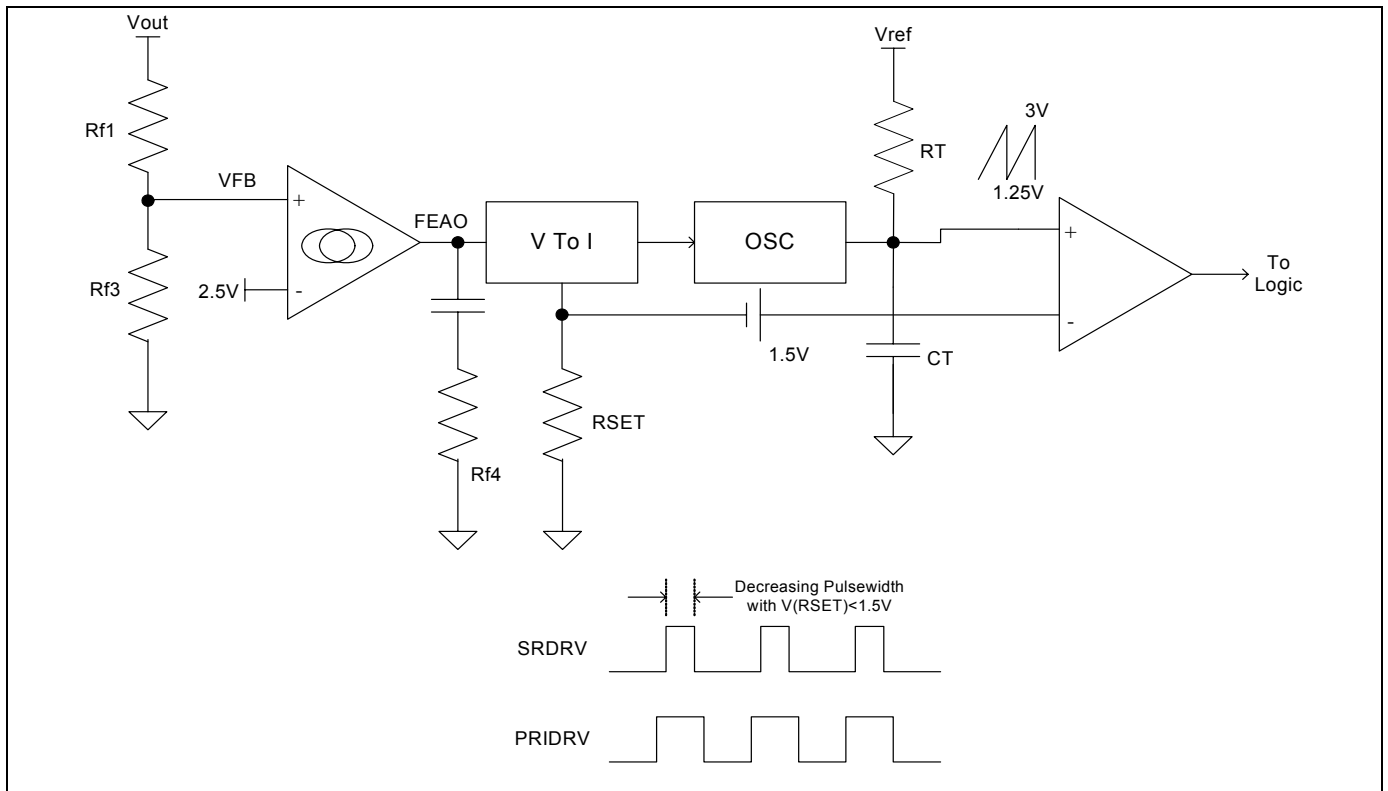

### Light Load PWMING

Light Load PWMING control is used in voltage mode. In Application1, when FEAO is equal to the external reference voltage at D\_IN+ due to light load, the frequency of the oscillator is fixed at a value determined by the voltage at FEAO, and the controller enters into PWM mode. In this mode, both frequency modulator and pulse width modulator are active.

In Application 2 ,the offset voltage  $V_{os}$  is externally generated between the  $V_{FB}$  pin and D\_IN- through a resistor network  $R_{f1}$ ,  $R_{f2}$  and  $R_{f3}$  in order to separate the interaction between FM mode and PWM mode.

$$V_{os} = 2.5V \times R_{f2} / R_{f3}$$

When the output load is reduced to a point where FEAO is railed to its maximum value of  $5V + V_{BE}$ , the frequency is fixed at a value determined by  $5V + V_{BE}$ . Further reduction in load will cause the controller to go into PWM mode when the voltage at the VFB pin is  $2.5V + V_{os}$ . During this light load operation, FM error amplifier is in open-loop mode while PWM is in closed-loop mode. Compensation is accomplished by connecting R and C in series to the DEAO pin.

In Application 3 , low gain configuration accomplished by connecting  $R_{f4}$  and  $R_{f5}$  in the closed loop configuration . The gain for the PWM is determined by  $R_{f4}$  and  $R_{f5}$  where the gain is equal to  $-R_{f5}/R_{f4}$ . The voltage of  $V_{Rset}$  at which the controller goes into FM and PWM simultaneously is equal to :

$$V_{Rset} = D\_IN+ \times (1+R_{f4}/R_{f5}) - (R_{f4}/R_{f5}) \times 3 \text{ where } 3 \text{ is the peak voltage of RTCT}$$

Varyin  $R_{set}$  from  $V_{Rset}$  to  $V_{Rset} + 1.75 \times R_{f4}/R_{f5}$  will cause the duty cycle to vary from 50% to 0% while the frequency will vary propotionally according to  $1.75 \times R_{f4}/R_{f5}$  where 1.75 is the peak-to-peak voltage of the RTCT ramp. For proper operation, select  $R_{f5}$  value so that the current through  $R_{f5}$   $\{((D\_IN+) - 1.2)/R_{f5}\}$  should be less than 5uA.

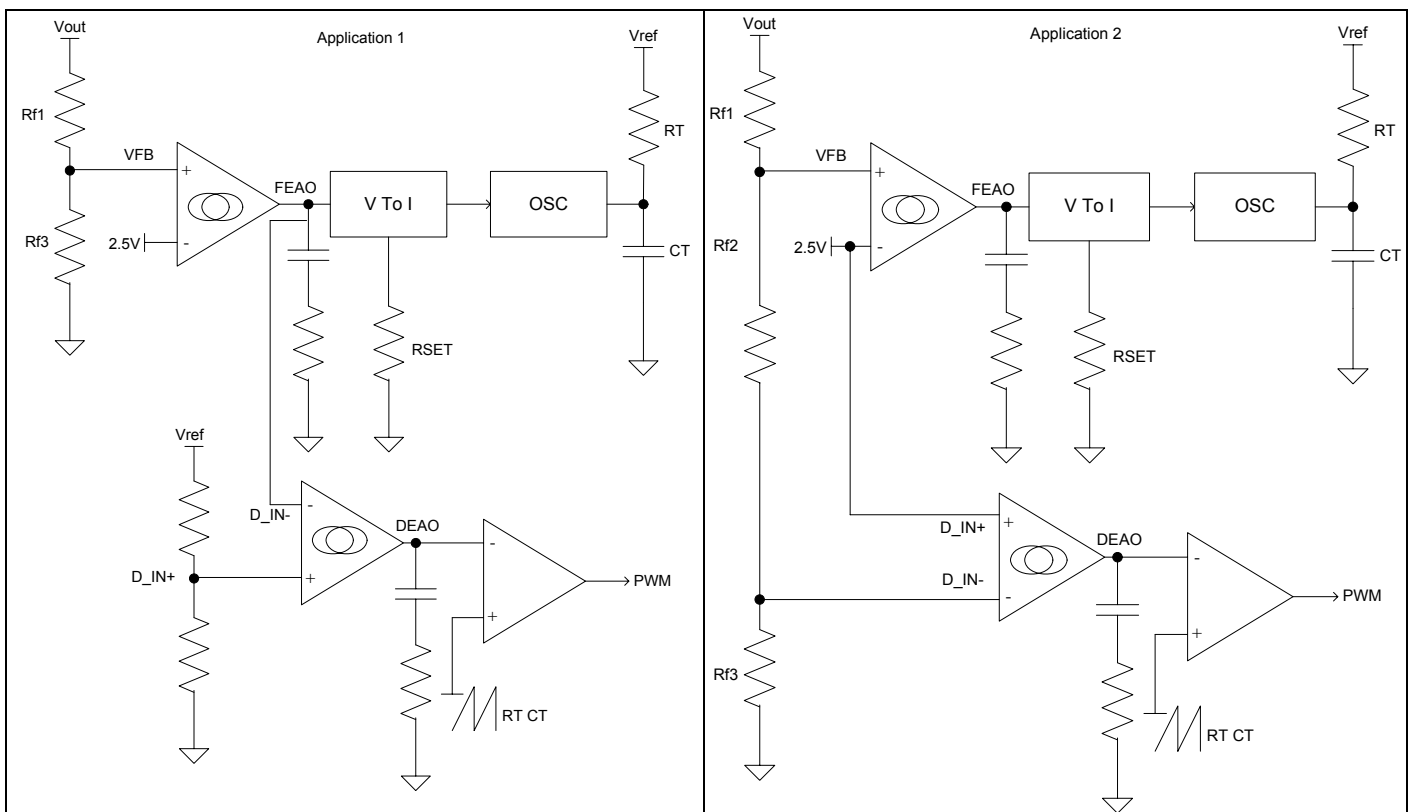

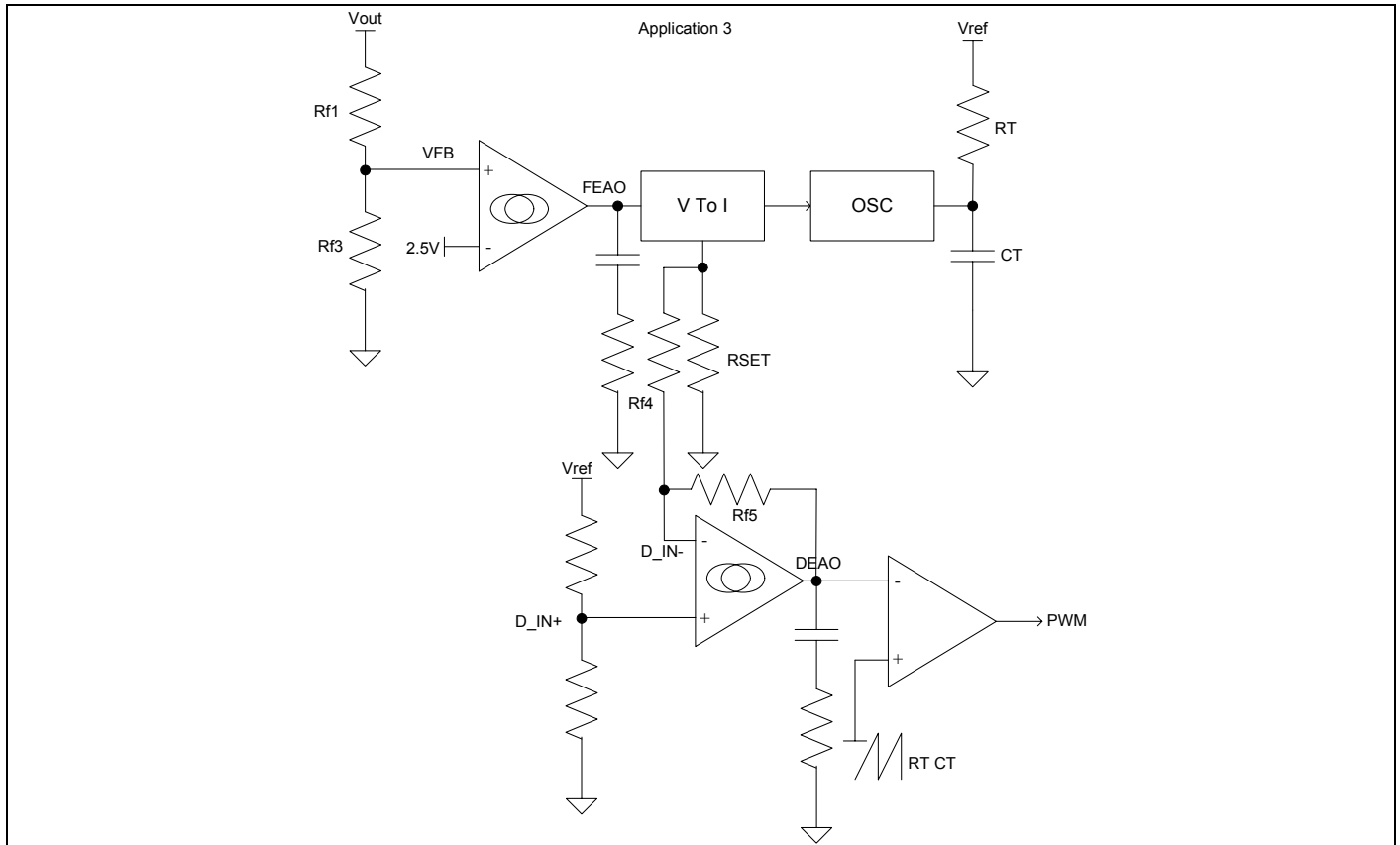

### Soft Start and Enable

Soft start of the FM and PWM is controlled by the selection of the external capacitor at CSS pin. A current source of 8uA supplies the charging current for the capacitor. Soft start of the FM and PWM begins at 1.25V. The soft start pin CSS also serves as an enable function. The output drivers are enabled when CSS pin reached 1V.

### Auto-retry Mode

During normal operation, CSS pin will be charged to  $5.5V + V_{BE}$ . When VFB exceeds 2.93V due to OVP or ILIM exceeds 1V due to over current condition, output drivers are immediate set to low, and CSS begins to discharge with 3.3uA current source. When CSS pin is below 0.9V, 8uA current source start charging the CSS pin. When CSS pin reaches 1V, the output drivers are re-enable and the controller goes into soft start mode. If OVP or over current condition still exists then, the outputs are immediately disabled, but CSS continues to charge toward 5V. When CSS reaches 5V, 8uA charging current is disabled and 3.3uA current source begins to discharge the CSS, and the cycle repeat until OVP or over current condition is removed.

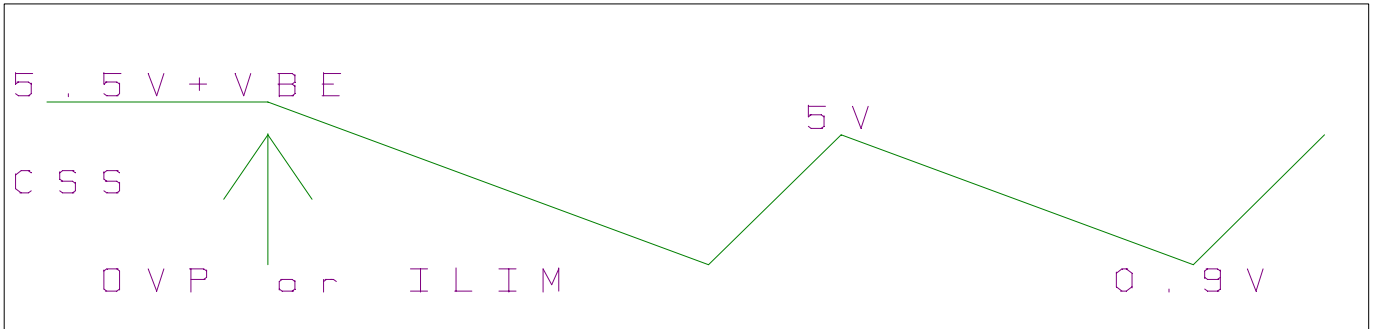

### PACKAGE DIMENSION

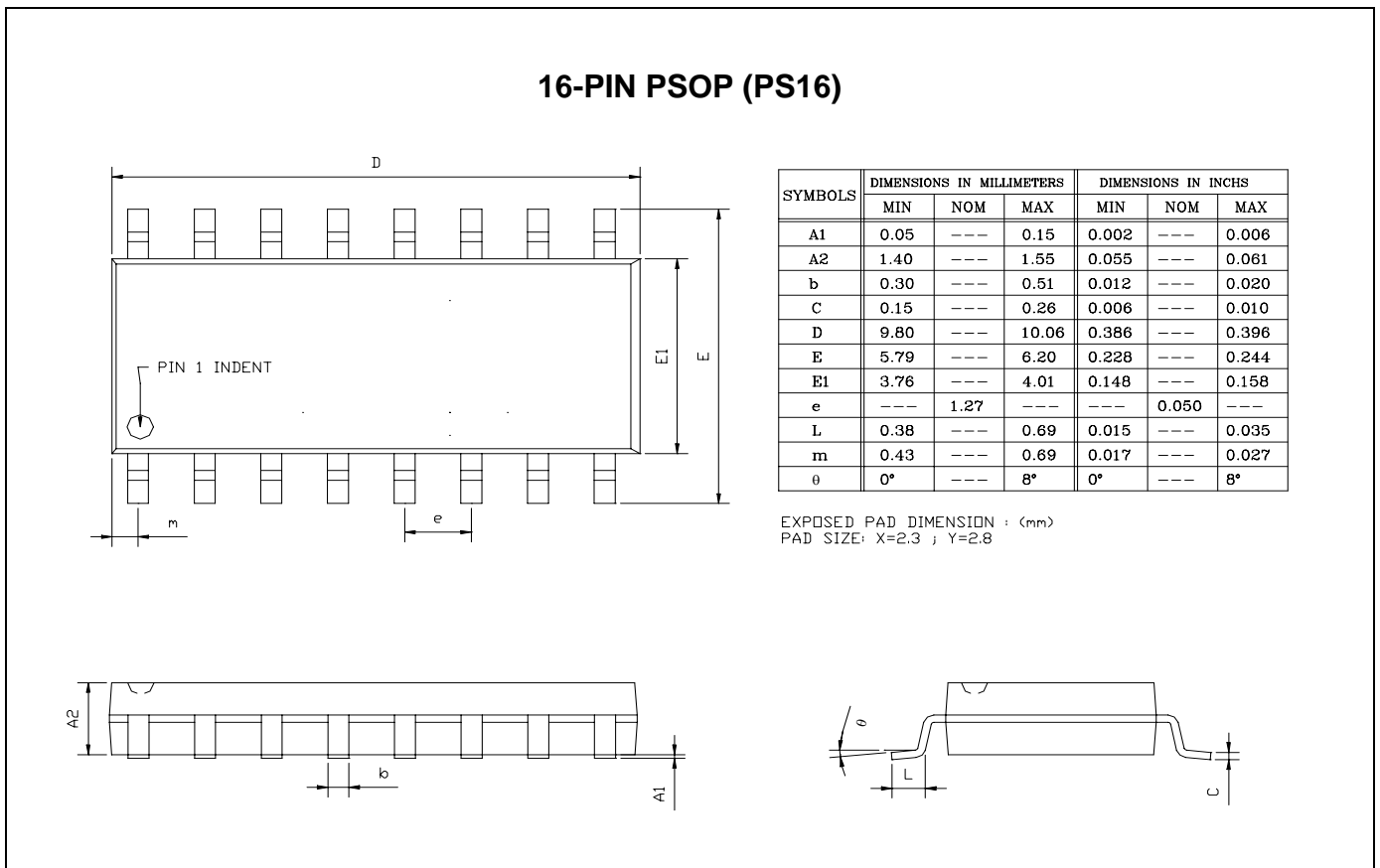

---

## IMPORTANT NOTICE

Champion Microelectronic Corporation (CMC) reserves the right to make changes to its products or to discontinue any integrated circuit product or service without notice, and advises its customers to obtain the latest version of relevant information to verify, before placing orders, that the information being relied on is current.

A few applications using integrated circuit products may involve potential risks of death, personal injury, or severe property or environmental damage. CMC integrated circuit products are not designed, intended, authorized, or warranted to be suitable for use in life-support applications, devices or systems or other critical applications. Use of CMC products in such applications is understood to be fully at the risk of the customer. In order to minimize risks associated with the customer's applications, the customer should provide adequate design and operating safeguards.

CMC assumes no liability to customer product design or application support. CMC warrants the performance of its products to the specifications applicable at the time of sale.

---

### HsinChu Headquarter

5F, No. 11, Park Avenue II,  
Science-Based Industrial Park,  
HsinChu City, Taiwan  
TEL: +886-3-5679979  
FAX: +886-3-5679909

---

### Sales & Marketing

7F-6, No.32, Sec. 1, Chenggong Rd.,  
Nangang District, Taipei City 115,  
Taiwan, R.O.C.  
TEL: +886-2-2788 0558  
FAX: +886-2-2788 2985

---