

GENERAL DESCRIPTION

The CM8501C is a low cost switching regulator designed to provide a desired output voltage or termination voltage for various applications by converting voltage supplies ranging from 2.0V to 4.5V. The CM8501C can be implemented to produce regulated output voltages in two different modes. In the default mode, when the VIN/2 pin is open, the output voltage is 50% of the VCCQ. The CM8501C can also be used to produce various user-defined voltages by forcing a voltage on the VIN/2 pin. In this case, the output voltage follows the VIN/2 pin input voltage. The regulated output voltage of CM8501C is internally set to be 50% of the applied VCCQ. The switching regulator is capable of sourcing or sinking up to 1.5A of current while regulating an output V_{TT} voltage to within 3% or less.

The CM8501C provides low profile 8-pin PSOP package to save system space.

FEATURES

- ◆ Patent Filed #6,452,366
- ◆ 8-pin SOP packages
- ◆ Source and sink up to 1.5A, no heat sink required
- ◆ Peak Current to 3A
- ◆ Integrated Power MOSFETs
- ◆ Output voltage can be programmed by external resistors
- ◆ Separate voltages for VCCQ and PVDD
- ◆ V_{OUT} of $\pm 3\%$ or less at 1.5A
- ◆ Minimum external components
- ◆ Shutdown for standby or suspend mode operation
- ◆ Thermal shutdown protection
- ◆ Soft start

APPLICATIONS

- ◆ Mother Board
- ◆ PCI/AGP Graphics
- ◆ Game/ Play Station
- ◆ Set Top Box
- ◆ IPC
- ◆ SCSI-III Bus terminator
- ◆ Buck Converter

PIN CONFIGURATION

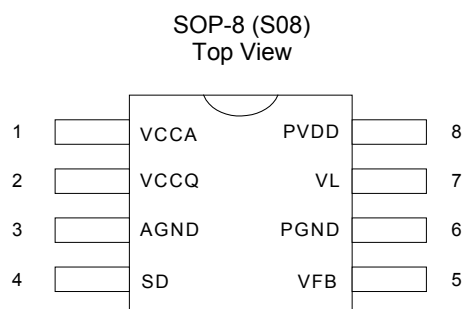

PIN DESCRIPTION

Pin No.	Symbol	Description	Operating Rating			
			Min.	Typ.	Max.	Unit
1	VCCA	Voltage supply for internal circuits	2.0		4.5	V
3	AGND	Ground for internal reference voltage divider				
4	SD	Shutdown active high. CMOS input level	0.75 x VCCA		VCCA + 0.3V	V
2	VCCQ	Voltage reference for external voltage divider		2.5		V
5	VFB	Feedback node for the V _{TT}		VCCQ/2		V
6	PGND	Ground for output power transistors				
7	VL	Output voltage/inductor connection (IDD1+IDD2, Output RMS current)	-1.5		+1.5	A
8	PVDD	Voltage supply for output power transistors	2.0		4.5	V

ORDERING INFORMATION

Part Number	Temperature Range	Package
CM8501CIS	-40°C to 85°C	8-Pin SOP (S08)
CM8501CGIS*	-40°C to 85°C	8-Pin SOP (S08)

*Note: G : Suffix for Pb Free Product

BLOCK DIAGRAM

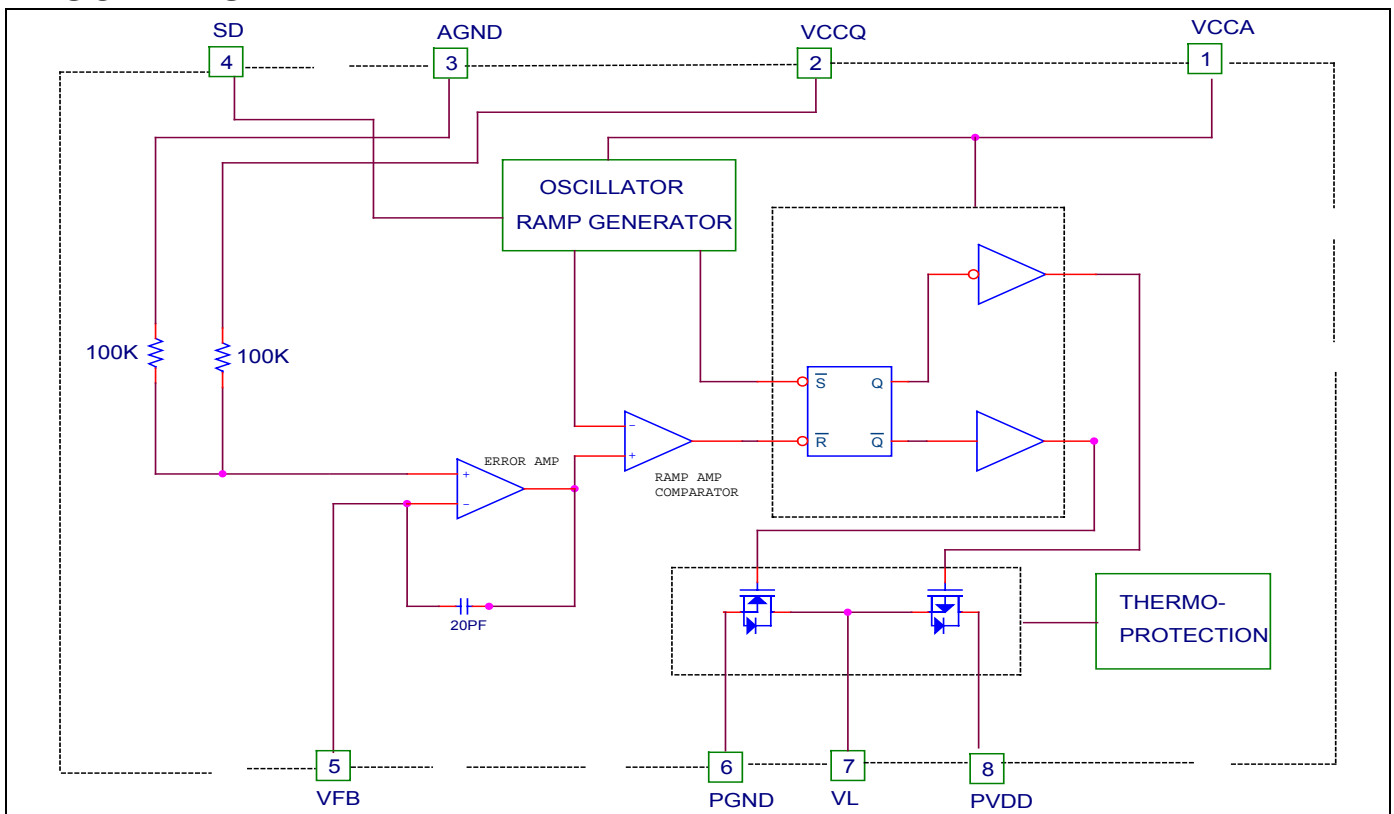

APPLICATION CIRCUITS

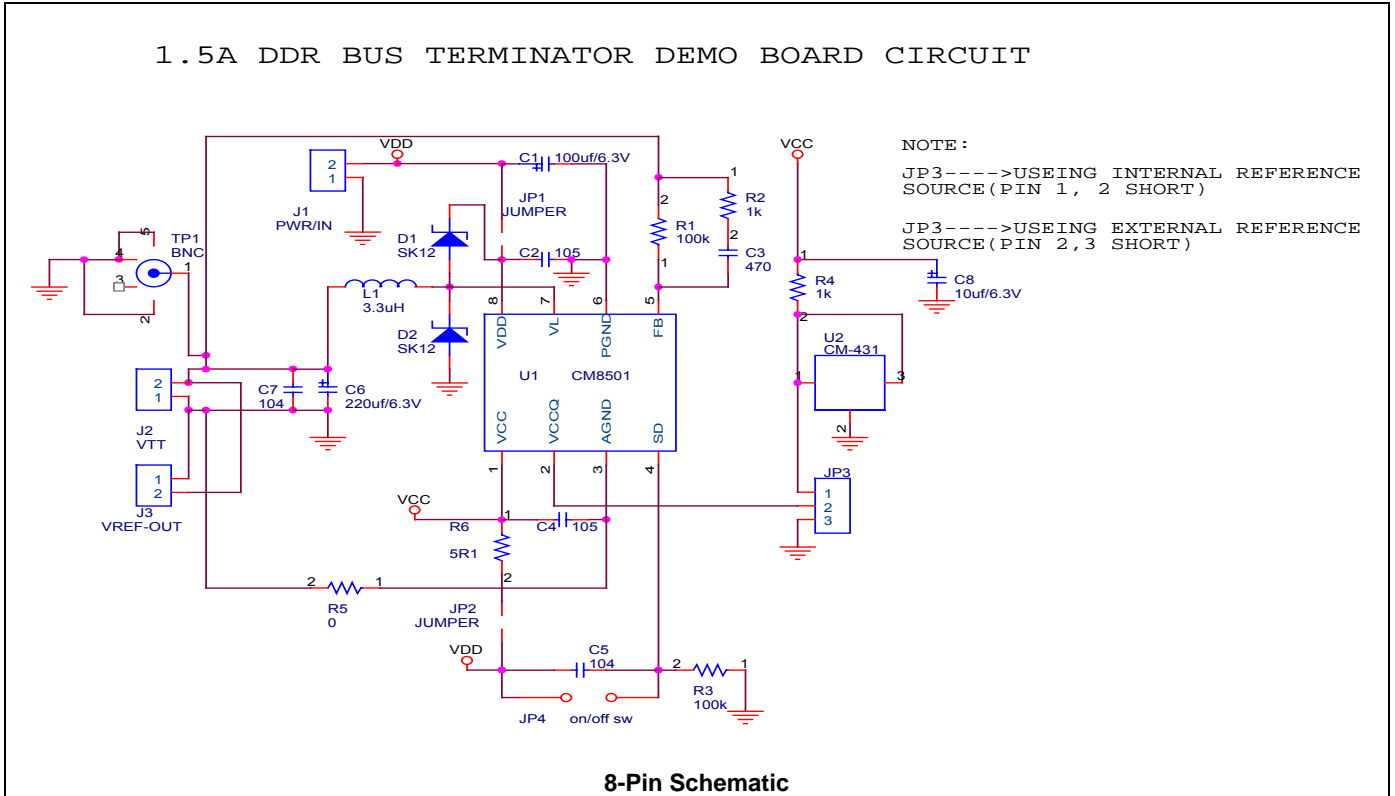

ABSOLUTE MAXIMUM RATINGS

Absolute maximum ratings are those values beyond which the device could be permanently damaged.

- PVDD/VCCA/VCCQ-0.3V to 4.5V
- Voltage on Any Other Pin GND – 0.3V to VCC + 0.3V
- Output RMS Current, Source or Sink1.5A

- Junction Temperature150°C
- Storage Temperature -65°C to 125°C
- Lead Temperature (Soldering, 5 sec)..... 300°C
- Thermal Resistance(θ_{JA})..... .100°C/W

OPERATING CONDITIONS

- Temperature Range -40°C to 85°C
- PVDD Operating Range2.0V to 4.5V

ELECTRICAL CHARACTERISTICS (Unless otherwise stated, these specifications apply $T_A=25^{\circ}\text{C}$; $V_{CCA}=+3.3\text{V}$ and $PVDD=+3.3\text{V}$) maximum ratings are stress ratings only and functional device operation is not implied.
(Note 1)

Symbol	Parameter	Test Conditions	CM8501C			Unit	
			Min.	Typ.	Max.		
SWITCHING REGULATOR							
VL	Output Voltage, SSTL_2	IOUT = 0, Note 2	VCCQ = 2.3V	1.12	1.15	1.18	V
			VCCQ = 2.5V	1.22	1.25	1.28	V
			VCCQ = 2.7V	1.32	1.35	1.38	V
		IOUT = $\pm 1.5\text{A}$, Note 2 Note 3	VCCQ = 2.3V	1.09	1.15	1.21	V
			VCCQ = 2.5V	1.19	1.25	1.31	V
			VCCQ = 2.7V	1.28	1.35	1.42	V
VIN/2	Internal Resistor Divider	IOUT = 0 Note 2	VCCQ = 2.3V	1.139	1.15	1.162	V
			VCCQ = 2.5V	1.238	1.25	1.263	V
			VCCQ = 2.7V	1.337	1.35	1.364	V
ZIN	VIN/2 Reference Pin Input Impedance	Note 2	VCCQ = 0		50		K Ω
fsw	Switching Frequency	CM8501C			1.2		MHz
IOUT(RMS)	Minimum Output RMS Current	CM8501C		1.5	2.0		A
IOUT(PEAK)	Maximum Output Peak Current	CM8501C				3	A
OTS	Over Temperature Shutdown	CM8501C		135	150		$^{\circ}\text{C}$
MOSFETS							
RDS(ON)	Drain to Source on-State Resistance	PVDD=5V			250		m Ω
SUPPLY							
IVCCA	Quiescent Current	VFB = 1.4V LC unconnected			220		μA
IPVDD		VFB = 1.4V LC unconnected			500		μA

Note 1: Limits are guaranteed by 100% testing, sampling, or correlation with worst case test conditions

Note 2: VCCA, PVDD = 3.3V $\pm 10\%$

Note 3: Guaranteed by design, not 100% test

FUNCTIONAL DESCRIPTION

The CM8501C is a switching regulator that is capable of sinking and sourcing 1.5A of current without an external heat sink.

The CM8501C integrates power MOSFETs that are capable of source and sink 1.5A of current while maintaining excellent voltage regulation. The output voltage can be regulated within 3% or less by using the external feedback. Separate voltage supply inputs have been added to fit applications with various power supplies for the databus and power buses.

OUTPUTS

The output voltage pins (VL) are tied to the databus, address, or clock lines via an external inductor. Output voltage is determined by the VCCQ and is determined by the VCCQ.

INPUTS

The input voltage pins (VCCQ) determine the output voltages (VL). At CM8501C, the output voltage is always 50% of the VCCQ input. VCCQ is suggested to connect to VCCQ of memory module for better tracking with memory VCCQ.

OTHER SUPPLY VOLTAGES

Several inputs are provided for the supply voltages: PVDD and VCCA

The PVDD provide the power supply to the power MOSFETs. VCCA provide the voltage supply to the logic section and internal error amplifiers of CM8501C.

FEEDBACK

The VFB pin is an input that can be used for closed loop compensation. This input is derived from the voltage output. AGSEN pin is a contact node of internal resistor divider for remote sense.

PACKAGE DIMENSION

8-PIN SOP (S08)

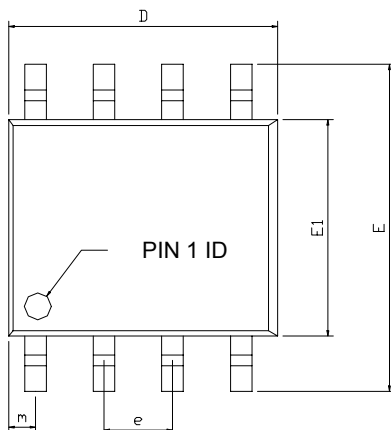

SYMBOLS	DIMENSIONS IN MILLIMETERS			DIMENSIONS IN INCHS		
	MIN	NOM	MAX	MIN	NOM	MAX
A1	0.10	----	0.25	0.004	----	0.010
A2	1.40	----	1.55	0.055	----	0.061
b	0.30	----	0.51	0.012	----	0.020
C	0.15	----	0.26	0.006	----	0.010
D	4.60	----	5.06	0.169	----	0.199
E	5.79	----	6.20	0.228	----	0.244
E1	3.76	----	4.01	0.148	----	0.158
e	----	1.27	----	----	0.050	----
L	0.38	----	0.69	0.015	----	0.035
m	0.43	----	0.69	0.017	----	0.027
θ	0°	----	8°	0°	----	8°

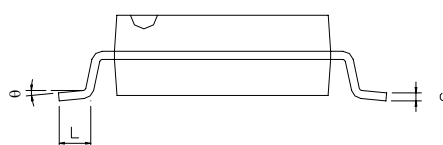
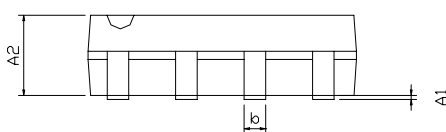

IMPORTANT NOTICE

Champion Microelectronic Corporation (CMC) reserves the right to make changes to its products or to discontinue any integrated circuit product or service without notice, and advises its customers to obtain the latest version of relevant information to verify, before placing orders, that the information being relied on is current.

A few applications using integrated circuit products may involve potential risks of death, personal injury, or severe property or environmental damage. CMC integrated circuit products are not designed, intended, authorized, or warranted to be suitable for use in life-support applications, devices or systems or other critical applications. Use of CMC products in such applications is understood to be fully at the risk of the customer. In order to minimize risks associated with the customer's applications, the customer should provide adequate design and operating safeguards.

HsinChu Headquarter

5F, No. 11, Park Avenue II,
Science-Based Industrial Park,
HsinChu City, Taiwan 300

TEL: +886-3-567 9979

FAX: +886-3-567 9909

<http://www.champion-micro.com>

Sales & Marketing

7F-6, No. 32, Sec. 1, Chenggong Rd.,
Nangang District, Taipei City 115, Taiwan

TEL: +886-2-2788 0558

FAX: +886-2-2788 2985