

3 Watt Audio Power Amplifier with Selectable Shutdown Logic Level

General Description

The CM8601 is an audio power amplifier primarily designed for demanding applications in mobile phones and other portable communication device applications. It is capable of delivering 1.25 watts of continuous average power to an 8 BTL load and 2 watts of continuous average power (LD and MH only) to a 4ΩBTL load with less than 1% distortion (THD+N+N) from a 5.5VDC power supply.

Boomer audio power amplifiers were designed specifically to provide high quality output power with a minimal amount of external components. The CM8601 does not require output coupling capacitors or bootstrap capacitors, and therefore is ideally suited for mobile phone and other low voltage applications where minimal power consumption is a primary requirement.

The CM8601 features a low-power consumption shutdown mode. To facilitate this, Shutdown may be enabled by either logic high or low depending on mode selection. Driving the shutdown mode pin either high or low enables the shutdown pin to be driven in a likewise manner to enable shutdown.

The CM8601 contains advanced pop & click circuitry which eliminates noise which would otherwise occur during turn-on and turn-off transitions.

The CM8601 is unity-gain stable and can be configured by external gain-setting resistors.

Key Specifications

- Ø Improved PSRR at 217Hz & 1KHz 62dB
- Ø Power Output at 3.0V, 1% THD+N, 4Ω 600mW (typ)
- Ø Power Output at 5.0V, 1% THD+N, 4Ω (LD and MH only) 3W (typ)
- Ø Power Output at 3.0V, 1% THD+N, 8Ω 425mW (typ)
- Ø Shutdown Current 0.1μA (typ)
- Ø Power Output at 5.0V, 1% THD+N, 8Ω 1.25W (typ)

Features

- Available in space-saving packages:SOP-8
- Ø Ultra low current shutdown mode
- Ø Improved pop & click circuitry eliminates noise during turn-on and turn-off transitions
- Ø 1.8 - 8.0V operation
- Ø No output coupling capacitors, snubber networks or bootstrap capacitors required
- Ø Unity-gain stable
- Ø External gain configuration capability
- Ø User selectable shutdown High or Low logic Level

Applications

- Ø Mobile Phones
- Ø PDAs
- Ø Portable electronic device

Connection Diagrams

SOP-8

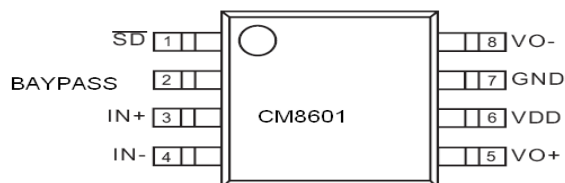

Package	LD	MH	MM	ITL
Shutdown Mode	Selectable	Selectable	Low	Low
Typical Power Output at 5V, 1% THD+N	3W ($R_L = 4\Omega$)	3W ($R_L = 4\Omega$)	1.25W ($R_L = 8\Omega$)	1.25W ($R_L = 8\Omega$)

- . A SD_MODE select pin determines the Shutdown Mode for the LD and MH packages, whether it is an Asserted High or an Asserted Low device, to activate shutdown.
- . The SD_MODE select pin is not available with the MM and ITL packaged devices. Shutdown occurs only with a low assertion.

Typical Application

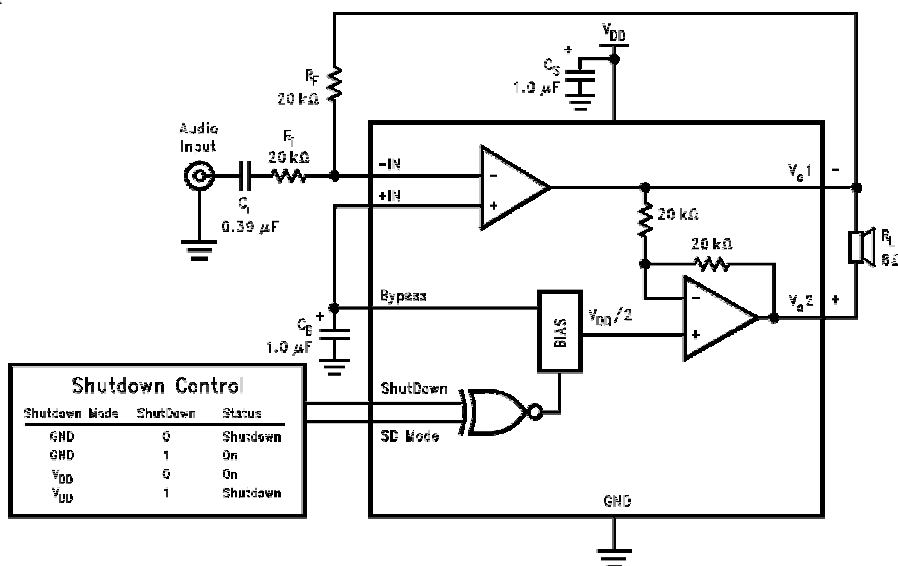

Note: MM and ITL packaged devices are active low only; Shutdown Mode pin is internally tied to GND.

FIGURE 1. Typical Audio Amplifier Application Circuit (LD and MH)

Absolute Maximum Ratings (Note 2)

If Military/Aerospace specified devices are required, please contact the National Semiconductor Sales Office/Distributors for availability and specifications.

Supply Voltage (Note 11)	6.0V
Storage Temperature	-65°C to +150°C
Input Voltage	-0.3V to VDD +0.3V
Power Dissipation (Notes 3, 12)	Internally Limited
ESD Susceptibility (Note 4)	2000V
ESD Susceptibility (Note 5)	200V
Junction Temperature	150°C
Thermal Resistance	
θJC (MSOP)	56°C/W
θJA (MSOP)	190°C/W
θJA (9 Bump micro SMD) (Note 15)	180°C/W

θ_{JA} (LLP) 63°C/W (Note 13)
 θ_{JC} (LLP) 12°C/W (Note 13)
 Soldering Information
 See AN-1187 "Leadless
 Leadframe Package (LLP)."

Operating Ratings

Temperature Range
 $T_{MIN} \leq T_A \leq T_{MAX}$ $-40^\circ\text{C} \leq T_A \leq 85^\circ\text{C}$
 Supply Voltage $2.2\text{V} \leq V_{DD} \leq 5.5\text{V}$

Electrical Characteristics $V_{DD} = 5\text{V}$ (Notes 1, 2)

The following specifications apply for the circuit shown in Figure 1, unless otherwise specified. Limits apply for $T_A = 25^\circ\text{C}$.

Symbol	Parameter	Conditions	CM8601		Units (Limits)
			Typical	Limit	
			(Note 6)	(Notes 7, 9)	
I_{DD}	Quiescent power supply current	$V_{IN}=0\text{V}, I_O=0\text{A}$, No Load	3	7	mA(max)
		$V_{IN}=0\text{V}, I_O=0\text{A}$, 8 Ω Load	4	10	mA(max)
I_{SD}	Shutdown current	$V_{SD}=V_{SD \text{ Mode}}$ (Note 8)	0.1	2.0	uA(max)
V_{SDIH}	Shutdown voltage input high	$V_{SD \text{ Mode}}=V_{DD}$	1.5	--	V
V_{SDIL}	Shutdown voltage input low	$V_{SD \text{ Mode}}=V_{DD}$	1.3	--	V
V_{SDIH}	Shutdown voltage input high	$V_{SD \text{ Mode}}=GND$	1.5	--	V
V_{SDIL}	Shutdown voltage input low	$V_{SD \text{ Mode}}=GND$	1.3	--	V
V_{OS}	Output offset voltage		7	50	mV(max)
R_{OUT}	Resistor output to GND (Note 10)		8.5	9.7	K Ω (max)
				7.0	K Ω (min)
P_O	Output power (8 Ω)	THD+N=1% (max); f=1KHz	1.25	0.9	W(min)
	(4 Ω) (Note 13, 14)	THD+N=1% (max); f=1KHz	3	--	W
T_{WU}	Wake-up time		100	--	ms
THD+N+N	Total harmonic distortion + Noise	$P_O=0.5\text{Wrms}$; f=1KHz	0.2	--	%
PSRR	Power supply rejection ratio	Vripple=200mV sine p-p Input terminated with 10 Ω	60 (f=217Hz) 64 (f=1KHz)	55	dB(min)

Electrical Characteristics $V_{DD} = 3\text{V}$ (Notes 1, 2)

The following specifications apply for the circuit shown in Figure 1, unless otherwise specified. Limits apply for $T_A = 25^\circ\text{C}$.

Symbol	Parameter	Conditions	CM8601		Units (Limits)
			Typical	Limit	
			(Note 6)	(Notes 7, 9)	
I_{DD}	Quiescent power supply current	$V_{IN}=0\text{V}, I_O=0\text{A}$, No Load	2	7	mA(max)
		$V_{IN}=0\text{V}, I_O=0\text{A}$, 8 Ω Load	3	9	mA(max)
I_{SD}	Shutdown current	$V_{SD}=V_{SD \text{ Mode}}$ (Note 8)	0.1	2.0	uA(max)
V_{SDIH}	Shutdown voltage input high	$V_{SD \text{ Mode}}=V_{DD}$	1.1	--	V
V_{SDIL}	Shutdown voltage input low	$V_{SD \text{ Mode}}=V_{DD}$	0.9	--	V

V_{SDIH}	Shutdown voltage input high	$V_{SD\ MODE=GND}$	1.3	--	V
V_{SDIL}	Shutdown voltage input low	$V_{SD\ MODE=GND}$	1.0	--	V
V_{OS}	Output offset voltage	--	7	50	mV(max)
R_{OUT}	Resistor output to GND (Note 10)	--	8.5	9.7	K Ω (max)
				7.0	K Ω (min)

Electrical Characteristics $V_{DD} = 3V$ (Notes 1, 2)

The following specifications apply for the circuit shown in Figure 1, unless otherwise specified. Limits apply for TA = 25°C.

Symbol	Parameter	Conditions	CM8601		Units (Limits)
			Typical (Note 6)	Limit (Notes 7, 9)	
PO	Output power (8 Ω)	THD+N=1%; f=1KHz	425	--	mW
	(4 Ω)	THD+N=1%; f=1KHz	600	--	mW
TWU	Wake-up time		75	--	ms
THD+N+N	Total harmonic distortion +Noise	Po=0.25Wrms; f=1KHz	0.1	--	%
PSRR	Power supply rejection ratio	$V_{ripple} = 200mV$ sine p-p Input terminated with 10 Ω	62 (f=217Hz) 68 (f=1KHz)	55	dB (min)

Electrical Characteristics $V_{DD} = 2.6V$ (Notes 1, 2)

The following specifications apply for the circuit shown in Figure 1, unless otherwise specified. Limits apply for TA = 25°C.

Symbol	Parameter	Conditions	CM8601		Units (Limits)
			Typical (Note 6)	Limit (Notes 7, 9)	
I_{DD}	Quiescent power supply current	$V_{IN}=0V, I_O=0A, No\ Load$	2.0	--	mA(max)
		$V_{IN}=0V, I_O=0A, 8\Omega\ Load$	3.0	--	mA(max)
I_{SD}	Shutdown current	$V_{SD}=V_{SD\ Mode}$ (Note 8)	0.1	--	uA(max)
V_{SDIH}	Shutdown voltage input high	$V_{SD\ MODE}=V_{DD}$	1.0	--	V
V_{SDIL}	Shutdown voltage input low	$V_{SD\ MODE}=V_{DD}$	0.9	--	V
V_{SDIH}	Shutdown voltage input high	$V_{SD\ MODE}=GND$	1.2	--	V
V_{SDIL}	Shutdown voltage input low	$V_{SD\ MODE}=GND$	1.0	--	V
V_{OS}	Output offset voltage	--	5	50	mV(max)
R_{OUT}	Resistor output to GND (Note 10)	--	8.5	9.7	K Ω (max)
				7.0	K Ω (min)
P_O	Output power (8 Ω)	THD+N=1% (max); f=1KHz	300	--	W(min)
	(4 Ω)	THD+N=1% (max); f=1KHz	400	--	W
T_{WU}	Wake-up time	--	70	--	ms
THD+N+N	Total harmonic distortion + Noise	$P_O=0.5Wrms; f=1KHz$	0.1	--	%
PSRR	Power supply rejection ratio	$V_{ripple}=200mV$ sine p-p Input terminated with 10 Ω	51 (f=217Hz) 51 (f=1KHz)	--	dB(min)

Note 1: All voltages are measured with respect to the ground pin, unless otherwise specified.

Note 2: *Absolute Maximum Ratings* indicate limits beyond which damage to the device may occur. *Operating Ratings* indicate conditions for which the device is functional, but do not guarantee specific performance limits. *Electrical Characteristics* state DC and AC electrical specifications under particular test conditions which guarantee specific performance limits. This assumes that the device is within the Operating Ratings. Specifications are not guaranteed for parameters where no limit is given, however, the typical value is a good indication of device performance.

Note 3: The maximum power dissipation must be dated at elevated temperatures and is dictated by T_{JMAX} , θ_{JA} , and the ambient temperature T_A . The maximum allowable power dissipation is $P_{DMAX} = (T_{JMAX} - T_A) / \theta_{JA}$ or the number given in Absolute Maximum Ratings, whichever is lower. For the CM8601, see power debating curves for additional information.

Note 4: Human body model, 100pF discharged through a 1.5k Ω resistor.

Note 5: Machine Model, 220pF – 240pF discharged through all pins.

Note 6: Typical values are measured at 25°C and represent the parametric norm.

Note 7: Limits are guaranteed to National’s AOQL (Average Outgoing Quality Level).

Note 8: For micro SMD only, shutdown current is measured in a Normal Room Environment. Exposure to direct sunlight will increase I_{SD} by a maximum of 2 μ A.

Note 9: Datasheet min/max specification limits are guaranteed by design, test, or statistical analysis.

Note 10: RROUT is measured from the output pin to ground. This value represents the parallel combination of the 10k Ω output resistors and the two 20k Ω resistors.

Note 11: If the product is in Shutdown mode and VDD exceeds 6V (to a max of 8V VDD), then most of the excess current will flow through the ESD protection circuits. If the source impedance limits the current to a max of 10mA, then the device will be protected. If the device is enabled when VDD is greater than 5.5V and less than 6.5V, no damage will occur, although operation life will be reduced. Operation above 6.5V with no current limit will result in permanent damage.

Note 12: Maximum power dissipation in the device (P_{DMAX}) occurs at an output power level significantly below full output power. P_{DMAX} can be calculated using Equation 1 shown in the **Application Information** section. It may also be obtained from the power dissipation graphs.

Electrical Characteristics $V_{DD} = 2.6V$ (Notes 1, 2)

The following specifications apply for the circuit shown in Figure 1, unless otherwise specified. Limits apply for $T_A = 25^\circ C$. (Continued)

Note 13: The Exposed-DAP of the LDA10B package should be electrically connected to GND or an electrically isolated copper area. the CM8601LD demo board

has the Exposed-DAP connected to GND with a PCB area of 86.7mils x 585mils (2.02mm x 14.86mm) on the copper top layer and 550mils x 710mils (13.97mm × 18.03mm) on the copper bottom layer.

Note 14: The thermal performance of the LLP and exposed-DAP TSSOP packages when used with the exposed-DAP connected to a thermal plane is sufficient for driving 4 Ω loads. The MSOP and ITL packages do not have the thermal performance necessary for driving 4 Ω loads with a 5V supply and is not recommended for this application.

Note 15: All bumps have the same thermal resistance and contribute equally when used to lower thermal resistance. All bumps must be connected to achieve specified thermal resistance.

External Components Description

See (Figure 1)

Components		Functional Description
1	Ri	Inverting input resistance which sets the closed-loop gain in conjunction with Rf. This resistor also forms a high pass filter with Ci at $f_C = 1 / (2\pi R_i C_i)$.
2	Ci	Inverting input resistance which sets the closed-loop gain in conjunction with Rf. This resistor also forms a high pass filter with Ci at $f_C = 1 / (2\pi R_i C_i)$.
3	Rf	Feedback resistance which sets the closed-loop gain in conjunction with Ri.
4	Cs	Supply bypass capacitor which provides power supply filtering. Refer to the Power Supply Bypassing section for information concerning proper placement and selection of the supply bypass capacitor.
5	CB	Bypass pin capacitor which provides half-supply filtering. Refer to the section, Proper Selection of External Components , for information concerning proper placement and selection of CB.

Typical Performance Characteristics

LD and MH Specific Characteristics

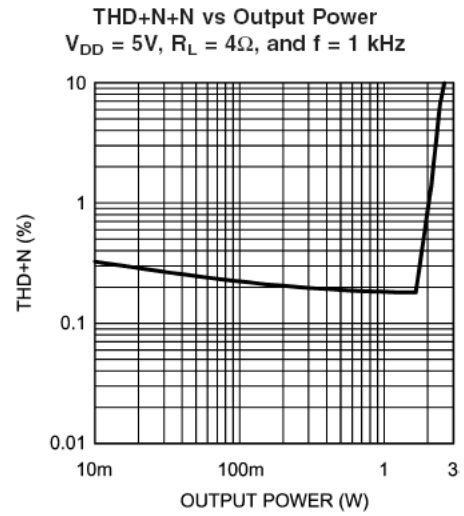
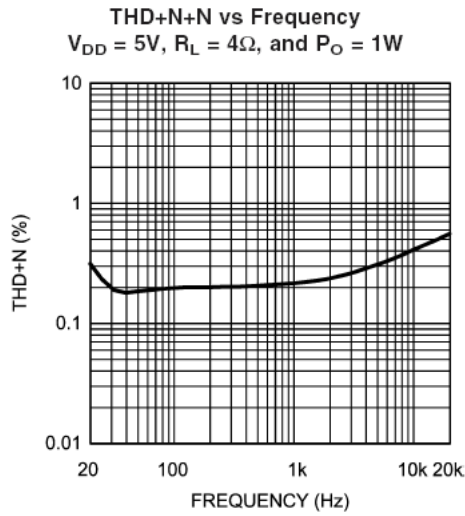

Typical Performance Characteristics

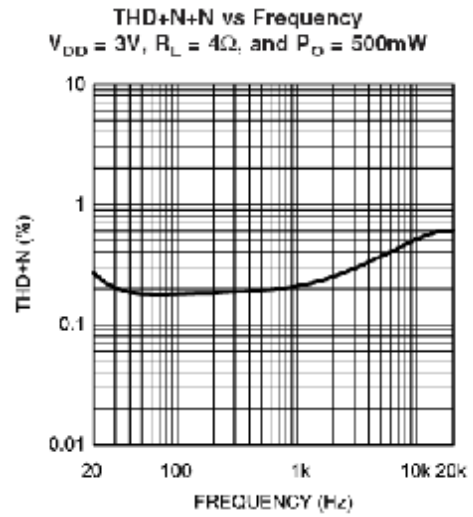
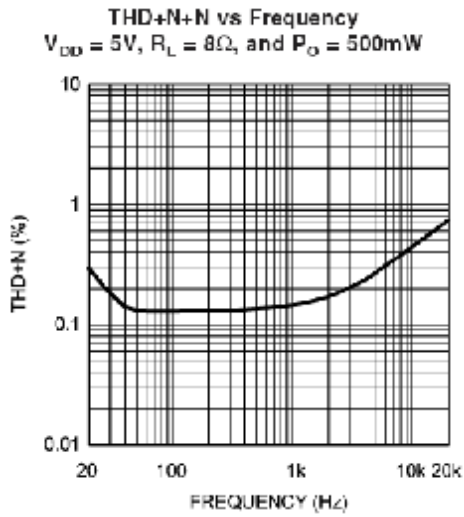

THD+N+N vs Frequency
 $V_{DD} = 3V$, $R_L = 8\Omega$, and $P_O = 250mW$

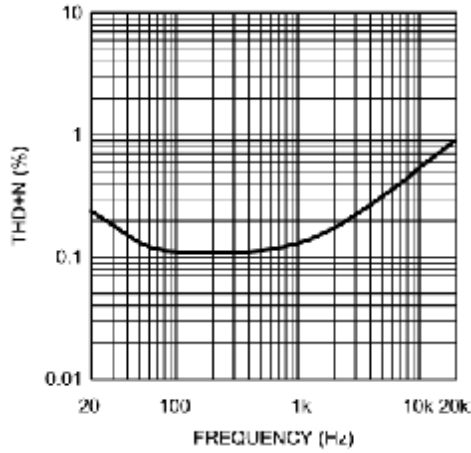

THD+N+N vs Frequency
 $V_{DD} = 2.6V$, $R_L = 4\Omega$, and $P_O = 150mW$

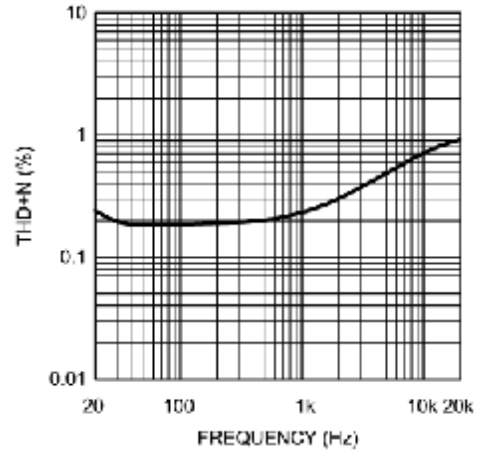

THD+N+N vs Output Power
 $V_{DD} = 2.6V$, $R_L = 8\Omega$, and $P_O = 150mW$

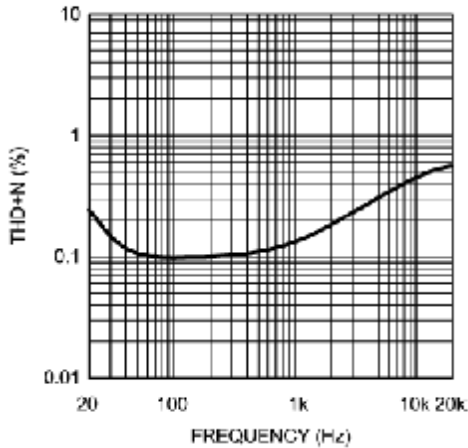

THD+N+N vs Output Power
 $V_{DD} = 5V$, $R_L = 8\Omega$, and $f = 1kHz$

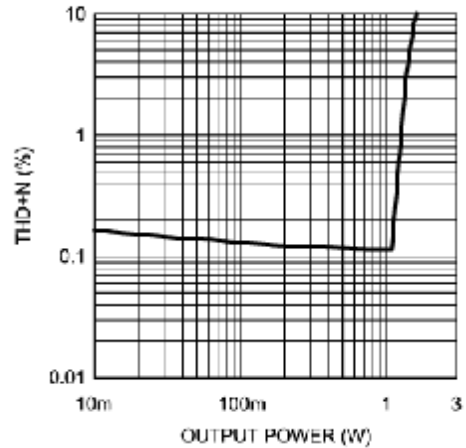

THD+N+N vs Output Power
 $V_{DD} = 3V$, $R_L = 4\Omega$, and $f = 1kHz$

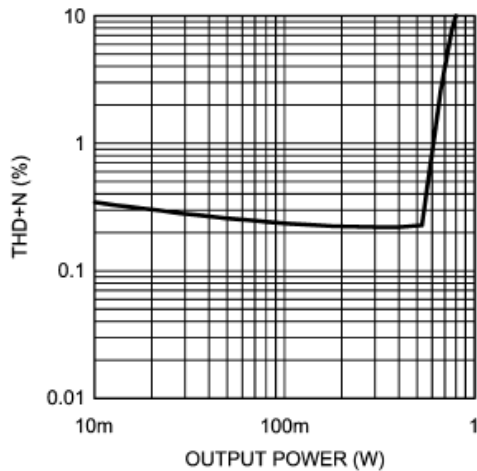

THD+N+N vs Output Power
 $V_{DD} = 3V$, $R_L = 8\Omega$, and $f = 1kHz$

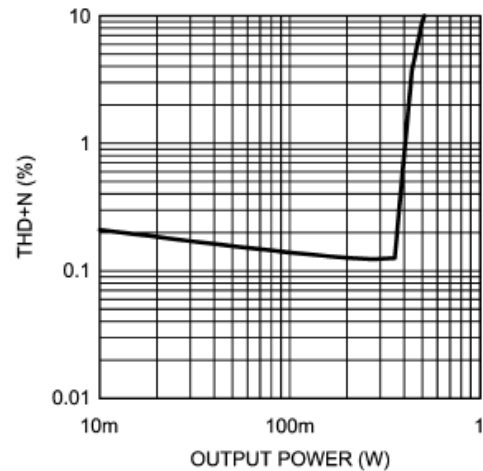

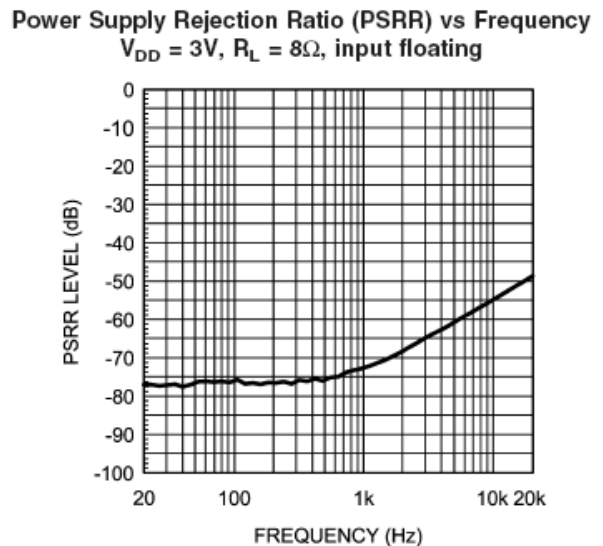
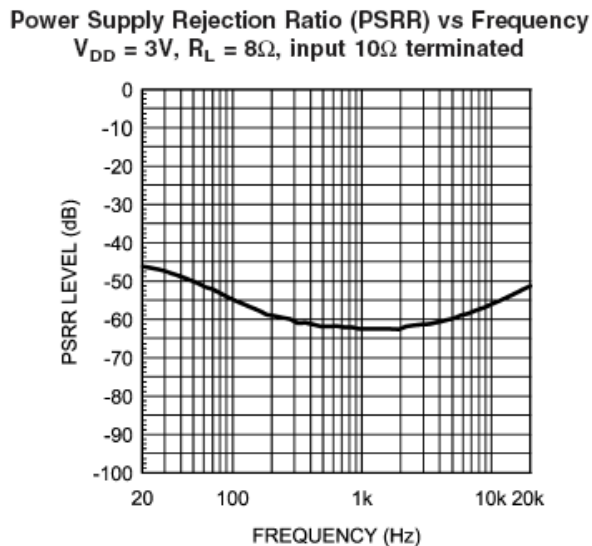
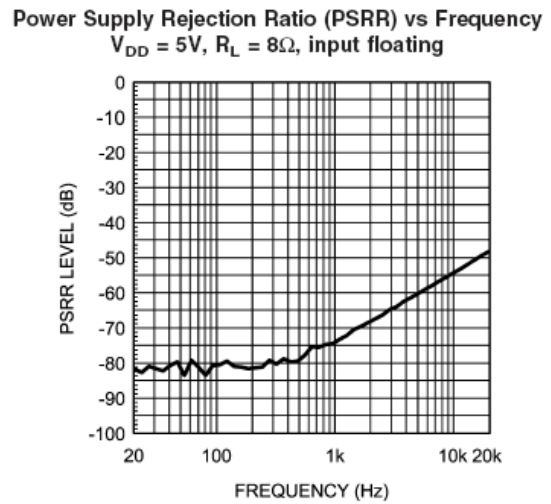
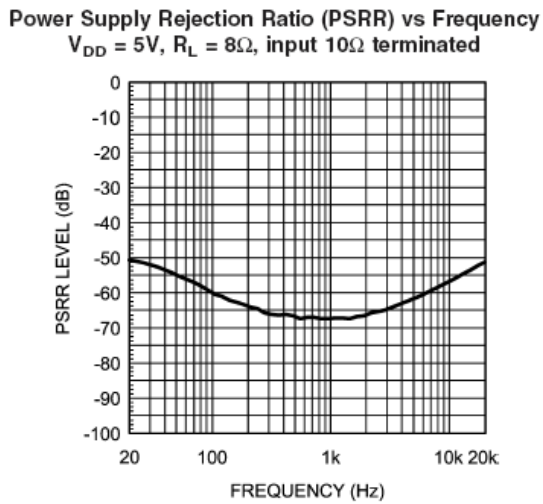
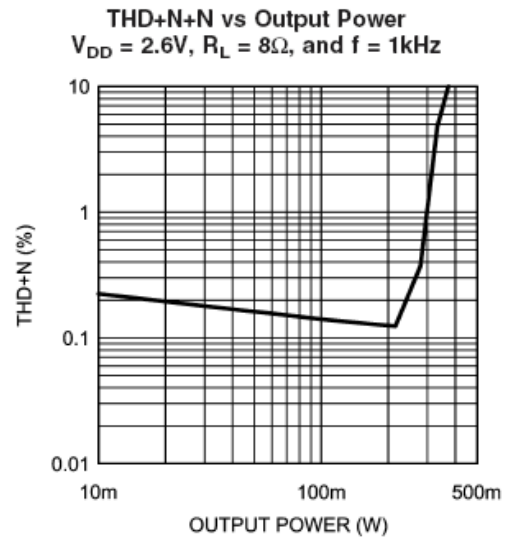
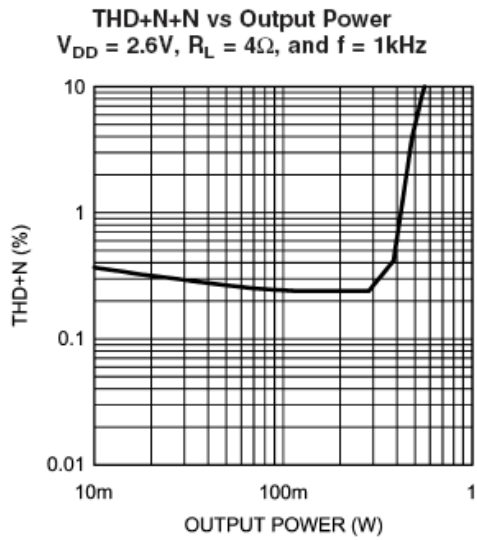

Power Supply Rejection Ratio (PSRR) vs Frequency
 $V_{DD} = 2.6V$, $R_L = 8\Omega$, input 10Ω terminated

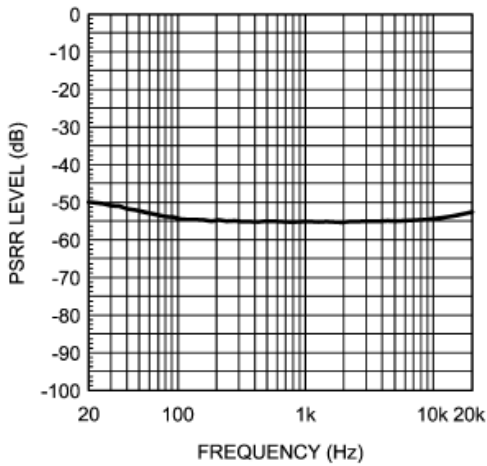

Power Supply Rejection Ratio (PSRR) vs Frequency
 $V_{DD} = 2.6V$, $R_L = 8\Omega$, Input Floating

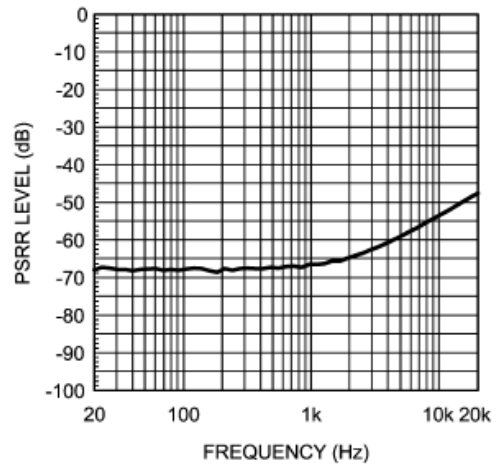

Open Loop Frequency Response, 5V

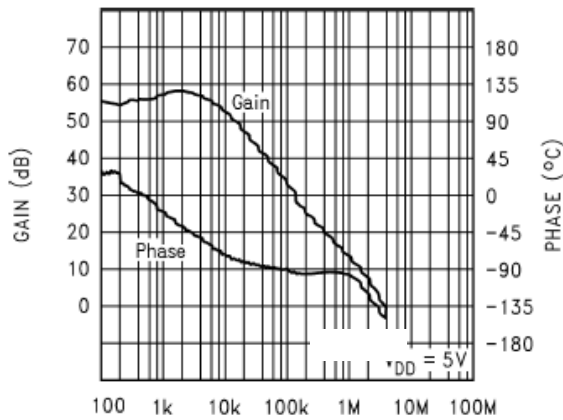

Noise Floor, 5V, 8Ω
 80kHz Bandwidth, Input to GND

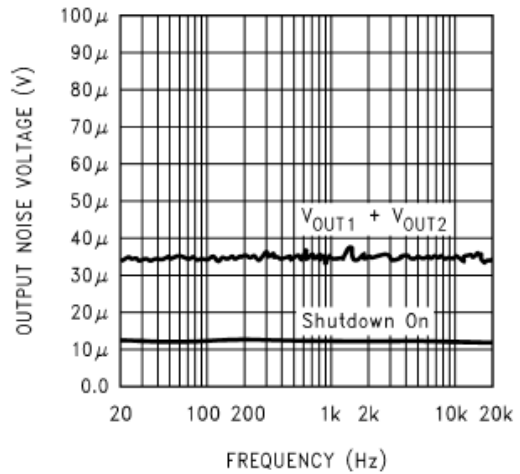

Power Dissipation vs Output Power, $V_{DD} = 5V$

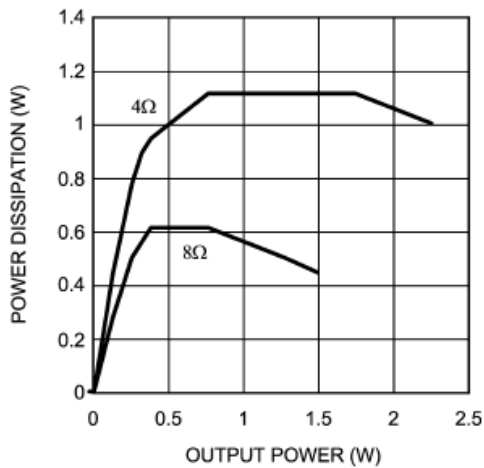

Power Dissipation vs Output Power, $V_{DD} = 3V$

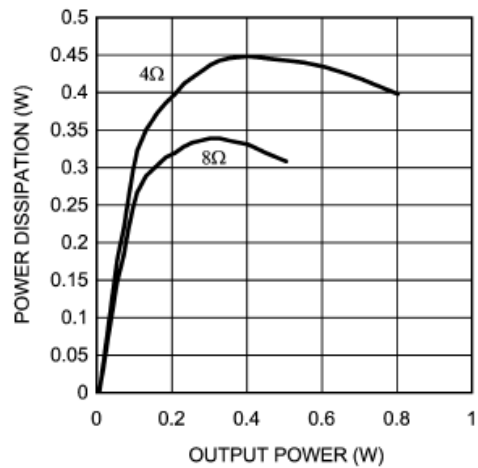

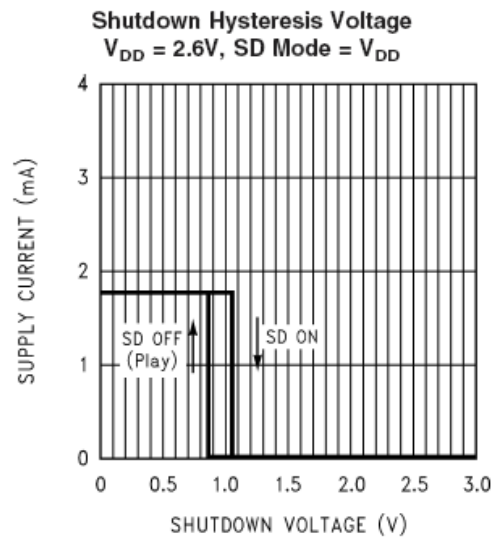
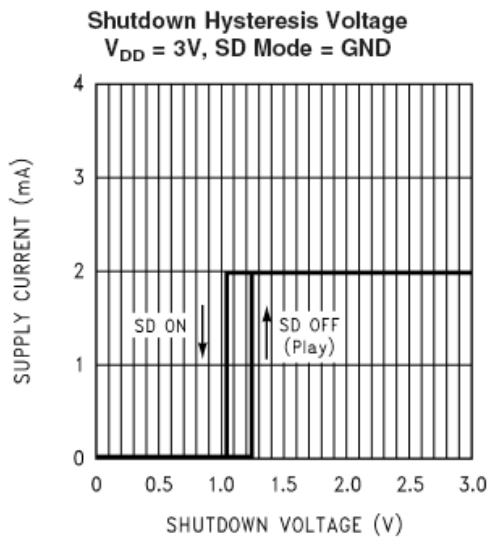
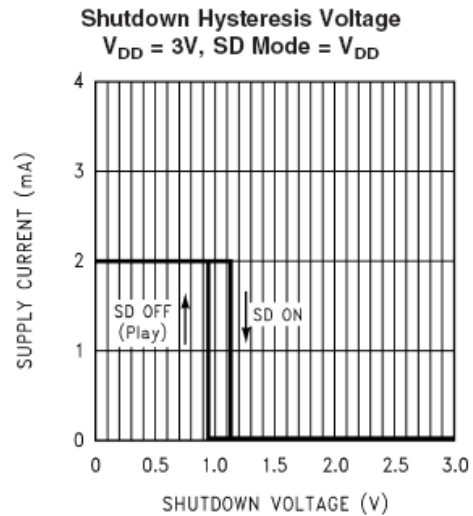
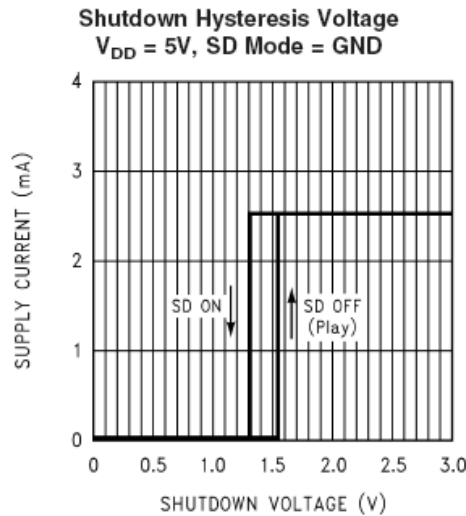
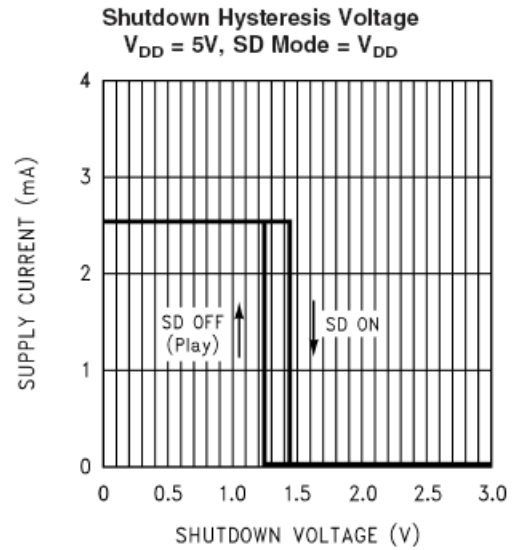
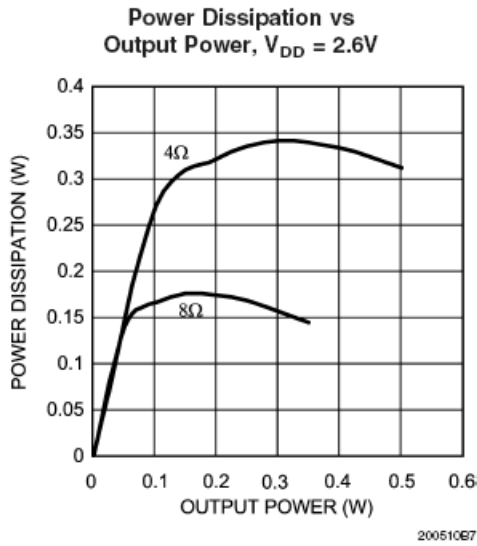

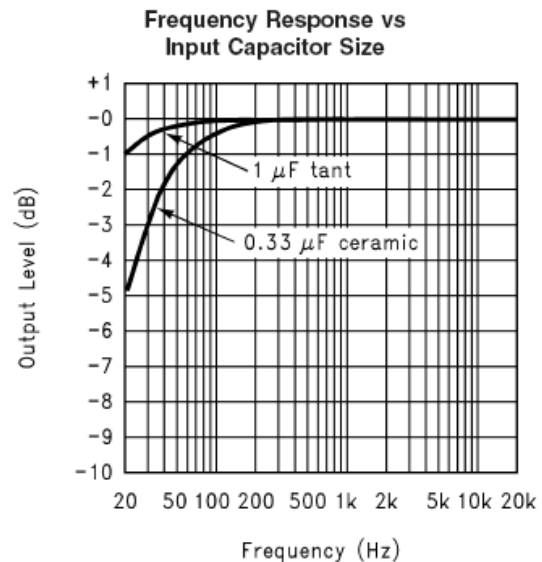
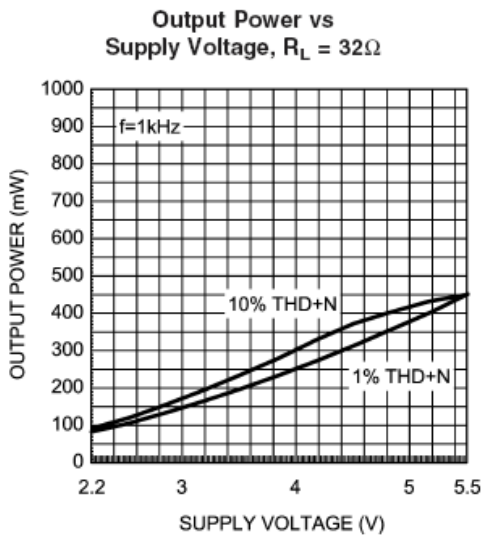
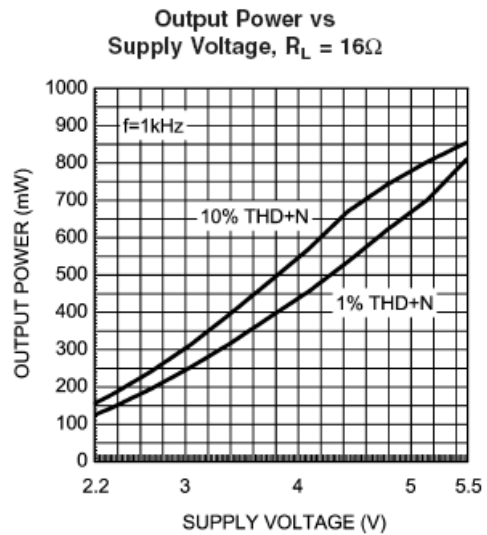
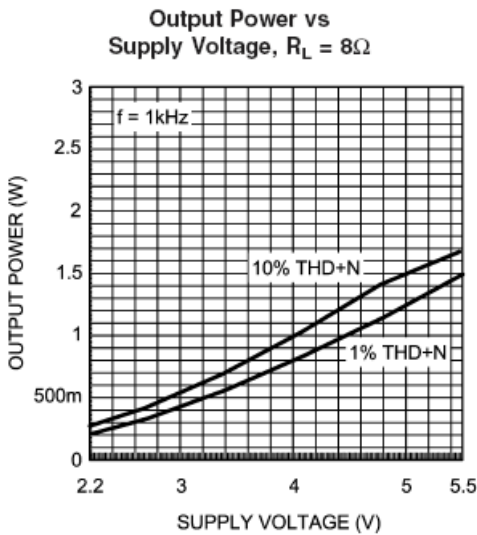
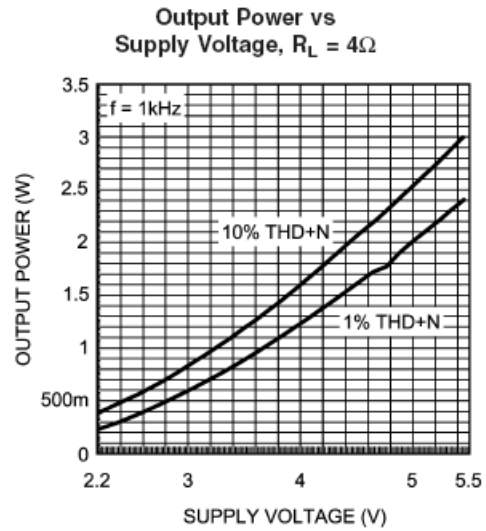
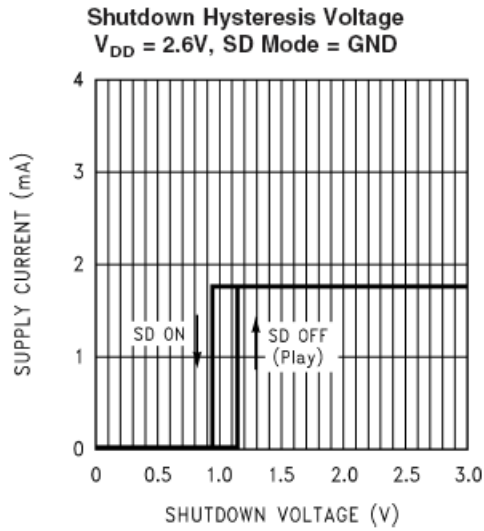

Application Information

BRIDGE CONFIGURATION EXPLANATION

As shown in *Figure 1*, the CM8601 has two internal operational amplifiers. The first amplifier's gain is externally configurable, while the second amplifier is internally fixed in a unity-gain, inverting configuration. The closed-loop gain of the first amplifier is set by selecting the ratio of R_f to R_i while the second amplifier's gain is fixed by the two internal 20k Ω resistors. *Figure 1* shows that the output of amplifier one serves as the input to amplifier two which results in both amplifiers producing signals identical in magnitude, but out of phase by 180°. Consequently, the differential gain for the IC is

$$AVD = 2 * (R_f/R_i)$$

By driving the load differentially through outputs V_{o1} and V_{o2} , an amplifier configuration commonly referred to as “bridged mode” is established. Bridged mode operation is different from the classical single-ended amplifier configuration where one side of the load is connected to ground. A bridge amplifier design has a few distinct advantages over the single-ended configuration, as it provides differential drive to the load, thus doubling output swing for a specified supply voltage. Four times the output power is possible as compared to a single-ended amplifier under the same conditions. This increase in attainable output power assumes that the amplifier is not current limited or clipped. In order to choose an amplifier's closed-loop gain without causing excessive clipping, please refer to the **Audio Power Amplifier Design** section.

A bridge configuration, such as the one used in CM8601, also creates a second advantage over single-ended amplifiers. Since the differential outputs, V_{o1} and V_{o2} , are biased at half-supply, no net DC voltage exists across the load. This eliminates the need for an output coupling capacitor which is required in a single supply, single-ended amplifier configuration. Without an output coupling capacitor, the half-supply bias across the load would result in both increased internal IC power dissipation and also possible loudspeaker damage.

POWER DISSIPATION

Power dissipation is a major concern when designing a successful amplifier, whether the amplifier is bridged or single-ended. A direct consequence of the increased power delivered to the load by a bridge amplifier is an increase in internal power dissipation. Since the CM8601 has two operational amplifiers in one package, the maximum internal power dissipation is 4 times that of a single-ended amplifier. The maximum power dissipation for a given application can be derived from the power dissipation graphs or from Equation 1.

$$P_{D_{MAX}} = 4 * (V_{DD})^2 / (2\pi^2 R_{L}) \quad (1)$$

It is critical that the maximum junction temperature $T_{J_{MAX}}$ of 150°C is not exceeded. $T_{J_{MAX}}$ can be determined from the power derating curves by using $P_{D_{MAX}}$ and the PC board foil area. By adding copper foil, the thermal resistance of the application can be reduced from the free air value of θ_{JA} , resulting in higher $P_{D_{MAX}}$ values without thermal shutdown protection circuitry being activated. Additional copper foil can be added to any of the leads connected to the CM8601. It is especially effective when connected to VDD, GND, and the output pins. Refer to the application information on the CM8601 reference design board for an example of good heat sinking. If $T_{J_{MAX}}$ still exceeds 150°C, then additional changes must be made. These changes can include reduced supply voltage, higher load impedance, or reduced ambient temperature. Internal power dissipation is a function of output power. Refer to the **Typical Performance Characteristics** curves for power dissipation information for different output powers and output loading.

POWER SUPPLY BYPASSING

As with any amplifier, proper supply bypassing is critical for low noise performance and high power supply rejection. The capacitor location on both the bypass and power supply pins should be as close to the device as possible. Typical applications employ a 5V regulator with 10 μ F tantalum or electrolytic capacitor and a ceramic bypass capacitor which aid in supply stability. This does not eliminate the need for bypassing the supply nodes of the CM8601. The selection of a bypass capacitor, especially CB, is dependent upon PSRR requirements, click and pop performance (as explained in the section, **Proper Selection of External Components**), system cost, and size constraints.

SHUTDOWN FUNCTION

In order to reduce power consumption while not in use, the CM8601 contains shutdown circuitry that is used to turn off the amplifier's bias circuitry. In addition, the CM8601 contains a Shutdown Mode pin (LD and MH packages only), allowing the designer to designate whether the part will be driven into shutdown with a high level logic signal or a low level logic signal. This allows the designer maximum flexibility in device use, as the Shutdown Mode pin may simply be tied permanently to either VDD or GND to set the CM8601 as either a "shutdown-high" device or a "shutdown-low" device, respectively. The device may then be placed into shutdown mode by toggling the Shutdown pin to the same state as the Shutdown Mode pin. For simplicity's sake, this is called "shutdown same", as the CM8601 enters shutdown mode whenever the two pins are in the same logic state. The MM package lacks this Shutdown Mode feature, and is permanently fixed as a 'shutdown-low' device. The trigger point for either shutdown high or shutdown low is shown as a typical value in the Supply Current vs Shutdown Voltage

graphs in the **Typical Performance Characteristics** section. It is best to switch between ground and supply for maximum performance. While the device may be disabled with shutdown voltages in between ground and supply, the idle current may be greater than the typical value of 0.1 μ A. In either case, the shutdown pin should be tied to a definite voltage to avoid unwanted state changes.

In many applications, a microcontroller or microprocessor output is used to control the shutdown circuitry, which provides a quick, smooth transition to shutdown. Another solution is to use a single-throw switch in conjunction with an external pull-up resistor (or pull-down, depending on shutdown high or low application). This scheme guarantees that the shutdown pin will not float, thus preventing unwanted state changes.

PROPER SELECTION OF EXTERNAL COMPONENTS

Proper selection of external components in applications using integrated power amplifiers is critical to optimize device and system performance. While the CM8601 is tolerant of external component combinations, consideration to component values must be used to maximize overall system quality.

The CM8601 is unity-gain stable which gives the designer maximum system flexibility. The CM8601 should be used in low gain configurations to minimize THD+N+N values, and maximize the signal to noise ratio. Low gain configurations require large input signals to obtain a given output power. Input signals equal to or greater than 1V_{rms} are available from sources such as audio codec's. Please refer to the section, **Audio Power Amplifier Design**, for a more complete explanation of proper gain selection.

Besides gain, one of the major considerations is the closed loop bandwidth of the amplifier. To a large extent, the bandwidth is dictated by the choice of external components shown in *Figure 1*. The input coupling capacitor, C_i, forms a first order high pass filter which limits low frequency response. This value should be chosen based on needed frequency response for a few distinct reasons.

Selection of Input Capacitor Size

Large input capacitors are both expensive and space hungry for portable designs. Clearly, a certain sized capacitor is needed to couple in low frequencies without severe attenuation. But in many cases the speakers used in portable systems, whether internal or external, have little ability to reproduce signals below 100Hz to 150Hz. Thus, using a large input capacitor may not increase actual system performance.

In addition to system cost and size, click and pop performance is effected by the size of the input coupling capacitor, C_i. A larger input coupling capacitor requires more charge to reach its quiescent DC voltage (nominally 1/2 V_{DD}). This charge comes from the output via the feedback and is apt to create pops upon device enable. Thus, by minimizing the capacitor size based on necessary low frequency response, turn-on pops can be minimized.

Besides minimizing the input capacitor size, careful consideration should be paid to the bypass capacitor value. Bypass capacitor, C_B, is the most critical component to minimize turn-on pops since it determines how fast the CM8601 turns on. The slower the CM8601's outputs ramp to their quiescent DC voltage (nominally 1/2 V_{DD}), the smaller the turn-on pop. Choosing C_B equal to 1.0 μ F along with a small value of C_i (in the range of 0.1 μ F to 0.39 μ F), should produce a virtually click less and peoples shutdown function. While the device will function properly, (no oscillations or motor boating), with C_B equal to 0.1 μ F, the device will be much more susceptible to turn-on clicks and pops. Thus, a value of C_B equal to 1.0 μ F is recommended in all but the most cost sensitive designs.

AUDIO POWER AMPLIFIER DESIGN

A 1W/8 Ω Audio Amplifier

Given:

Power Output	1W _{rms}
Load Impedance	8 Ω
Input Level	1V _{rms}
Input Impedance	20k Ω
Bandwidth	100Hz–20kHz \pm 0.25dB

A designer must first determine the minimum supply rail to obtain the specified output power. By extrapolating from the Output Power vs Supply Voltage graphs in the **Typical Performance Characteristics** section, the supply rail can be easily found.

5V is a standard voltage in most applications, it is chosen for the supply rail. Extra supply voltage creates headroom that allows the CM8601 to reproduce peaks in excess of 1W without producing audible distortion. At this time, the designer must make sure that the power supply choice along with the output impedance does not violate the conditions explained in the **Power Dissipation** section. Once the power dissipation equations have been addressed, the required differential gain can be determined from Equation 2.

$$A_{VD} \geq \sqrt{(P_O R_L)} / (V_{IN}) = V_{orms} / V_{inrms} \quad (2)$$

$$R_f / R_i = A_{VD} / 2$$

From Equation 2, the minimum AVD is 2.83; use AVD = 3. Since the desired input impedance was 20kΩ, and with a AVD impedance of 2, a ratio of 1.5:1 of Rf to Ri results in an allocation of Ri = 20kΩ and Rf = 30kΩ. The final design step is to address the bandwidth requirements which must be stated as a pair of -3dB frequency points. Five times away from a -3dB point is 0.17dB down from pass band response which is better than the required ±0.25dB specified.

$$f_L = 100\text{Hz} / 5 = 20\text{Hz}$$

$$f_H = 20\text{kHz} * 5 = 100\text{kHz}$$

As stated in the **External Components** section, Ri in conjunction with Ci create a high pass filter.

$$C_i \geq 1 / (2\pi * 20\text{k}\Omega * 20\text{Hz}) = 0.397\mu\text{F}; \text{ use } 0.39\mu\text{F}$$

The high frequency pole is determined by the product of the desired frequency pole, fH, and the differential gain, AVD. With a AVD = 3 and fH = 100kHz, the resulting GBWP = 300kHz which is much smaller than the CM8601 GBWP of 2.5MHz. This figure displays that if a designer has a need to design an amplifier with a higher differential gain, the CM8601 can still be used without running into bandwidth limitations.

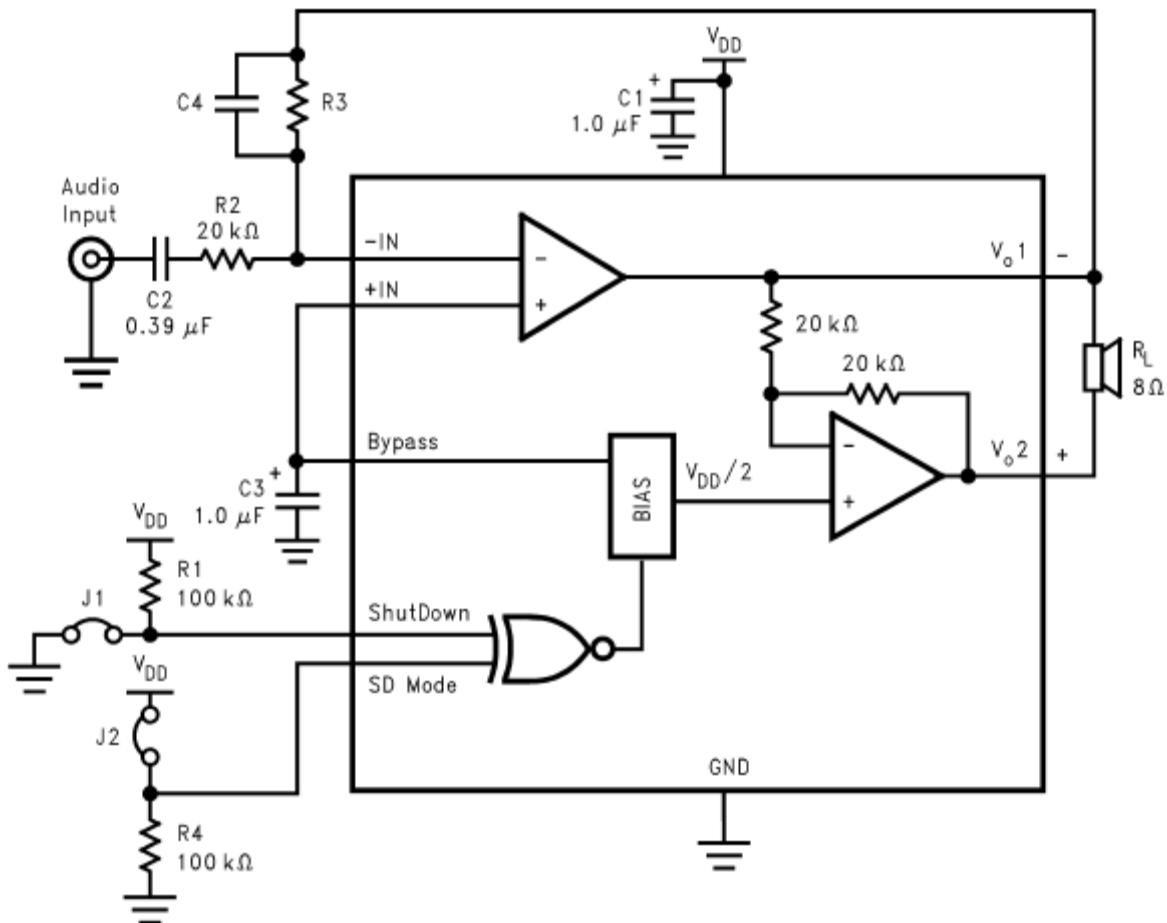

FIGURE 2. HIGHER GAIN AUDIO AMPLIFIER

The CM8601 is unity-gain stable and requires no external components besides gain-setting resistors, an input coupling capacitor, and proper supply bypassing in the typical application. However, if a closed-loop differential gain of greater than 10 is required, a feedback capacitor (C4) may be needed as shown in Figure 2 to bandwidth limit the amplifier. This feedback capacitor creates a low pass filter that eliminates possible high frequency oscillations. Care should be taken when calculating the -3dB frequency in that an incorrect combination of R3 and C4 will cause rolloff before 20kHz. A typical combination of feedback resistor and capacitor that will not produce audio band high frequency rolloff is R3 = 20kΩ and C4 = 25pf. These components result in a -3dB point of approximately 320kHz.

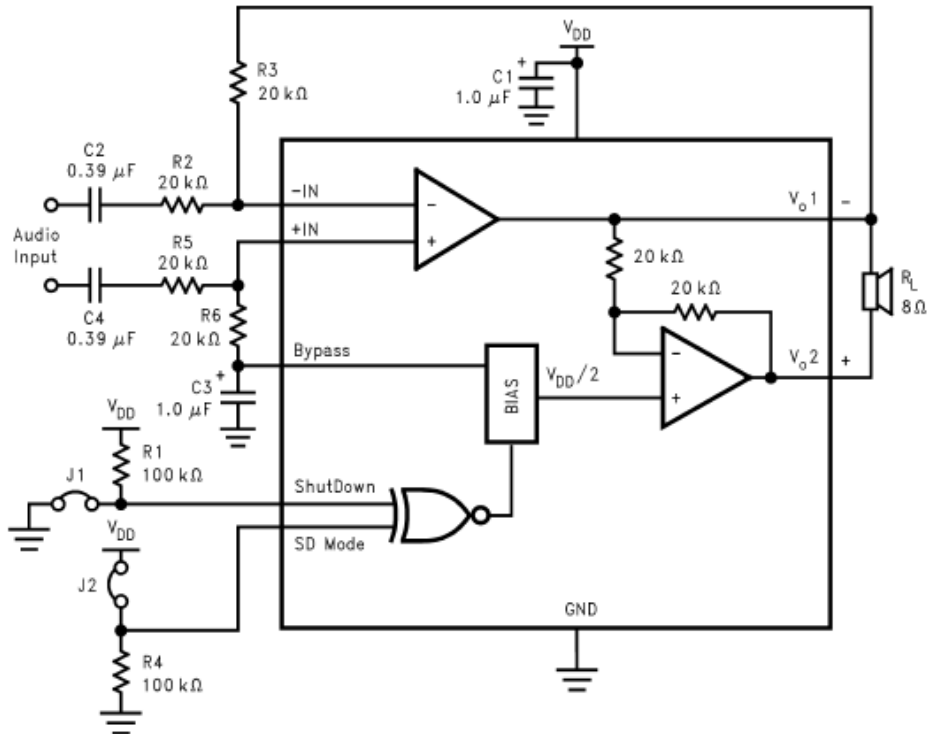

FIGURE 3. DIFFERENTIAL AMPLIFIER CONFIGURATION FOR CM8601

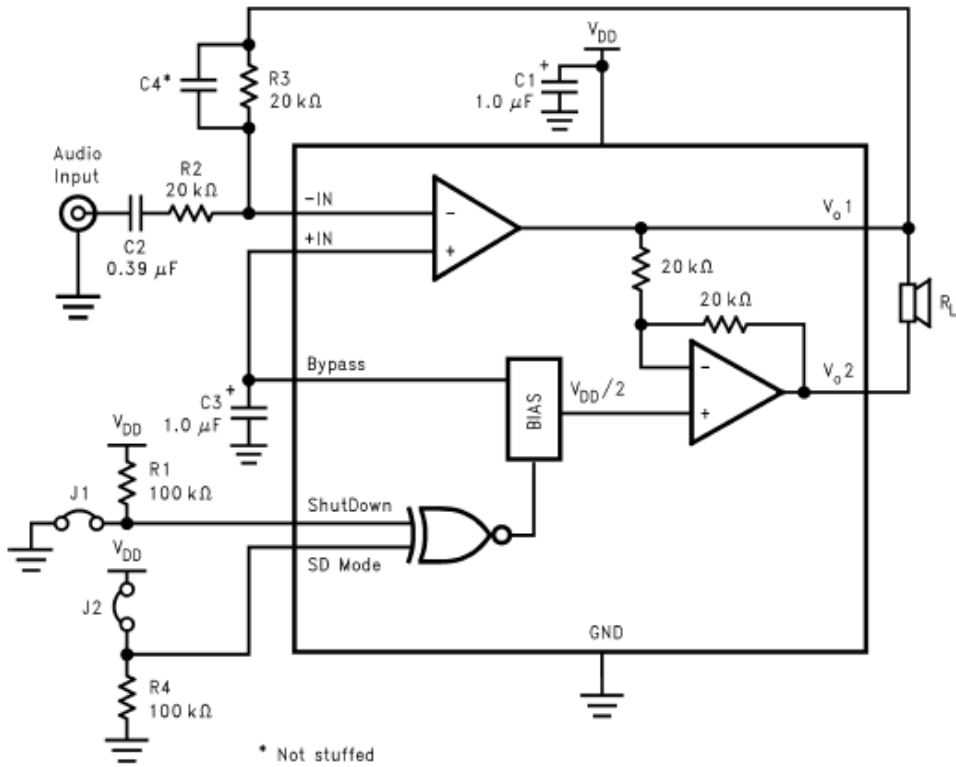

FIGURE 4. REFERENCE DESIGN BOARD SCHEMATIC

Physical Dimensions inches (millimeters) unless otherwise noted

