

### GENERAL DESCRIPTION

The CM8608 is an integrated class AB stereo headphone driver contained in an SO8 or a DIP8 plastic package. The device is fabricated in a 1 mm CMOS process and has been primarily developed for portable digital audio applications.

### FEATURES

- ◆ Wide temperature range
- ◆ No switch ON/OFF clicks
- ◆ Excellent power supply ripple rejection.
- ◆ Low power consumption
- ◆ Short-circuit resistant
- ◆ High performance
  - ◇ high signal-to-noise ratio
  - ◇ high slew rate
  - ◇ low distortion
- ◆ Large output voltage swing

### PIN CONFIGURATION

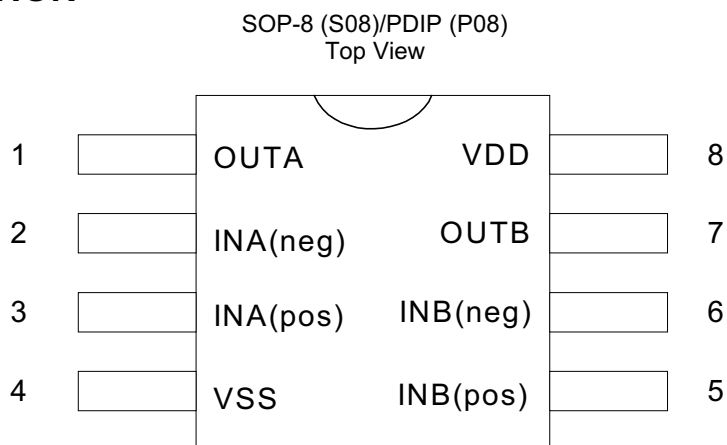

### PIN DESCRIPTION

Pin No.	Symbol	Description
1	OUTA	Output A
2	INA(neg)	Inverting input A
3	INA(pos)	Non-inverting input A
4	VSS	Negative supply
5	INB(pos)	Non-inverting input B
6	INB(neg)	Inverting input B
7	OUTB	Output B
8	VDD	Positive supply

### BLOCK DIAGRAM

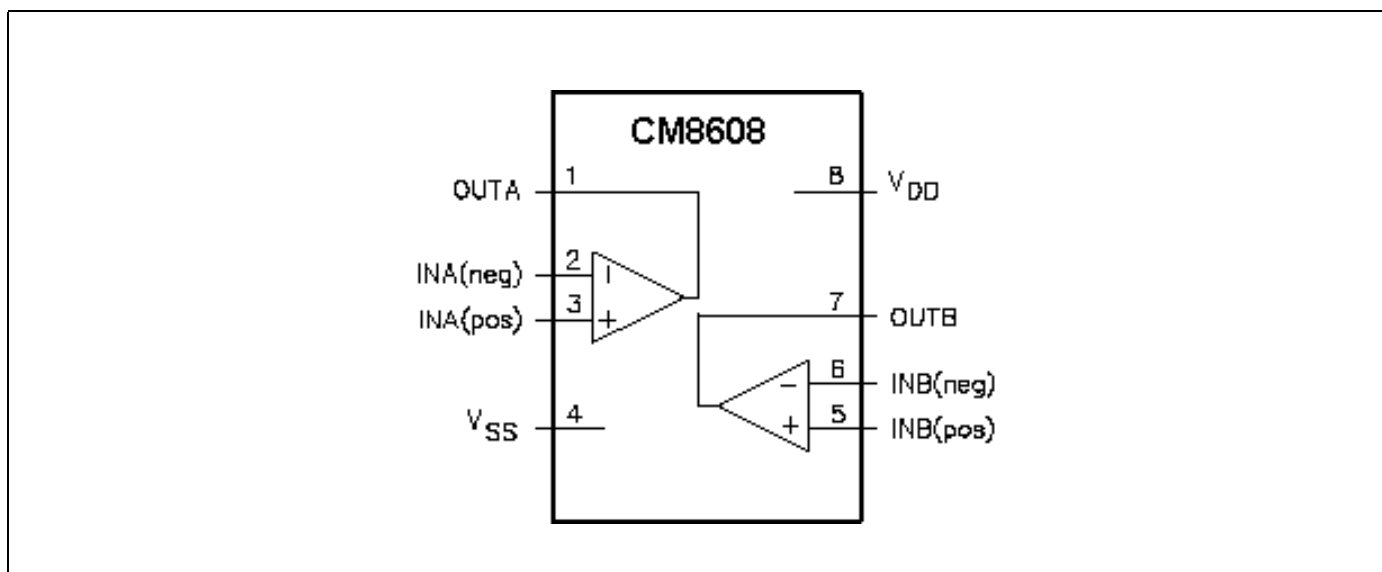

### ORDERING INFORMATION

Part Number	Temperature Range	Package
CM8608IP	-40°C to 85°C	8-Pin PDIP (P08)
CM8608IS	-40°C to 85°C	8-Pin SOP (S08)

### ABSOLUTE MAXIMUM RATINGS

Absolute Maximum ratings are those values beyond which the device could be permanently damaged.

SYMBOL	PARAMETER	CONDITIONS	MIN.	MAX.	UNIT
$V_{DD}$	supply voltage		0	8.0	V
$t_{SC(O)}$	output short-circuit duration	$T_{amb} = 25\text{ }^{\circ}\text{C}; P_{tot} = 1\text{ W}$	20	–	s
$T_{stg}$	storage temperature		-65	+150	$^{\circ}\text{C}$
$T_{amb}$	operating ambient temperature		-40	+85	$^{\circ}\text{C}$
$V_{esd}$	electrostatic discharge	note 1	-2000	+2000	V
		note 2	-200	+200	V

**THERMAL CHARACTERISTICS**

SYMBOL	PARAMETER	VALUE	UNIT
$R_{th\ j-a}$	thermal resistance from junction to ambient in free air		
	DIP8	109	K/W
	SO8	210	K/W

**TYPICAL APPLICATION**

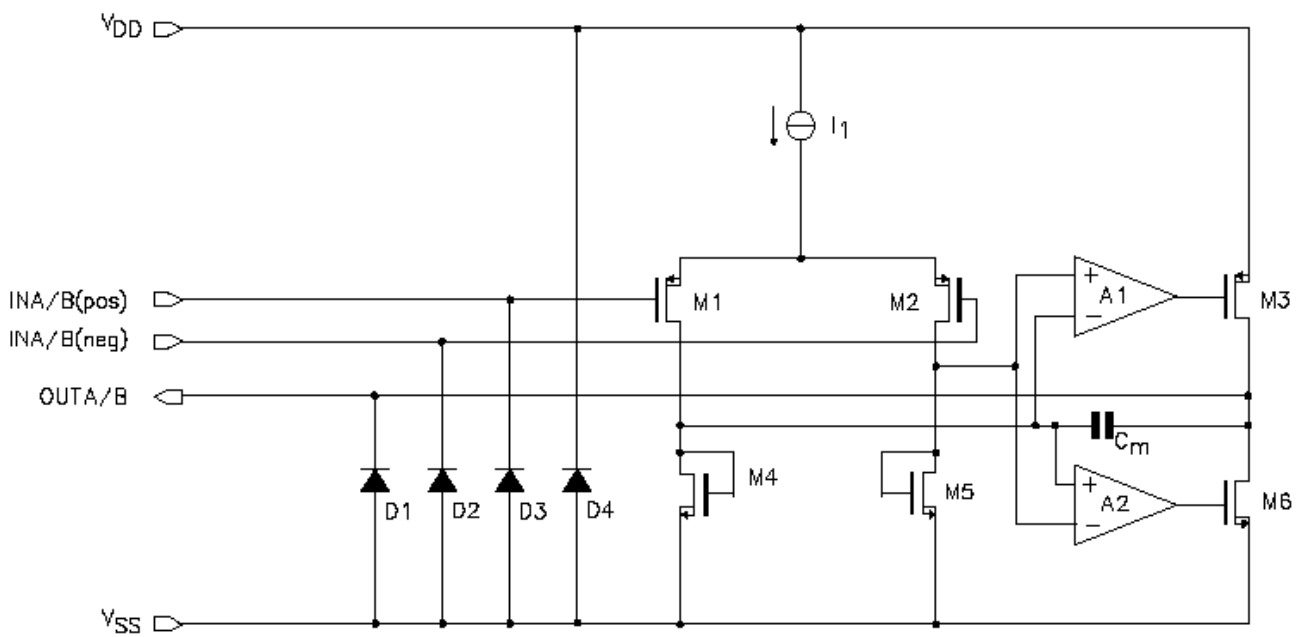

**ELECTRICAL CHARACTERISTICS** (Unless otherwise stated, these specifications apply  $T_A=25^\circ\text{C}$ ;  $V_{SS}=0\text{V}$ ,  $V_{DD}=+5\text{V}$ ,  $f_i = 1\text{kHz}$ ,  $R_L = 32\Omega$ ) maximum ratings are stress ratings only and functional device operation is not implied.

SYMBOL	PARAMETER	CONDITIONS	MIN.	TYP.	MAX.	UNIT
<b>Supplies</b>						
$V_{DD}$	supply voltage					
	single		3.0	5.0	7.0	V
	dual		1.5	2.5	3.5	V
$V_{SS}$	negative supply voltage		-1.5	-2.5	-3.5	V
$I_{DD}$	supply current	no load	-	3	5	mA
$P_{tot}$	total power dissipation	no load	-	15	25	mW
<b>DC characteristics</b>						
$V_{I(0s)}$	input offset voltage		-	10	-	mV
$I_{bias}$	input bias current		-	10	-	pA
$V_{CM}$	common mode voltage		0	-	3.5	V
$G_v$	open-loop voltage gain	$R_L = 5\text{ k}\Omega$	-	70	-	dB
$I_O$	maximum output current	$(\text{THD} + \text{N})/\text{S} < 0.1\%$	-	60	-	mA
$R_O$	output resistance		-	0.25	-	$\Omega$
$V_O$	output voltage swing	note 1	0.75	-	4.25	V
		$R_L = 16\ \Omega$ ; note 1	1.5	-	3.5	V
		$R_L = 5\ \text{k}\Omega$ ; note 1	0.1	-	4.9	V
PSRR	power supply rejection ratio	$f_i = 100\ \text{Hz}$ ; $V_{\text{ripple}(p-p)} = 100\ \text{mV}$	-	90	-	dB
$\alpha_{cs}$	channel separation		-	70	-	dB
		$R_L = 5\ \text{k}\Omega$	-	105	-	dB
$C_L$	load capacitance		-	-	200	pF
<b>AC characteristics</b>						
$(\text{THD} + \text{N})/\text{S}$	total harmonic distortion plus noise-to-signal ratio	note 2	-	-70	-65	dB
			-	0.03	0.06	%
		note 2; $R_L = 5\ \text{k}\Omega$	-	-101	-	dB
			-	0.0009	-	%
S/N	signal-to-noise ratio		100	110	-	dB
$f_G$	unity gain frequency	open-loop; $R_L = 5\ \text{k}\Omega$	-	5.5	-	MHz
$P_o$	maximum output power	$(\text{THD} + \text{N})/\text{S} < 0.1\%$	-	60	-	mW
$C_i$	input capacitance		-	3	-	pF
SR	slew rate	unity gain inverting	-	5	-	V/ $\mu\text{s}$
B	power bandwidth	unity gain inverting	-	20	-	kHz

**Notes**

1. Values are proportional to  $V_{DD}$ ;  $(\text{THD} + \text{N})/\text{S} < 0.1\%$ .
2.  $V_{DD} = 5.0\ \text{V}$ ;  $V_{O(p-p)} = 3.5\ \text{V}$  (at 0 dB).

### TEST INFORMATION

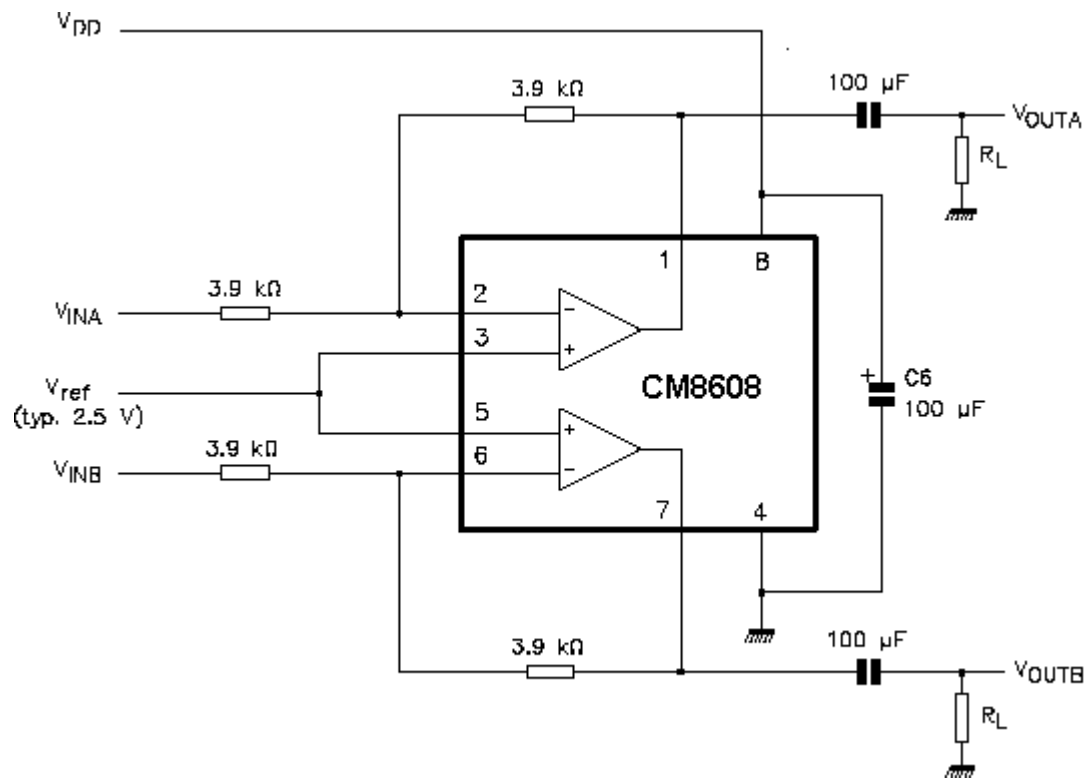

### TYPICAL CHARACTERISTICS

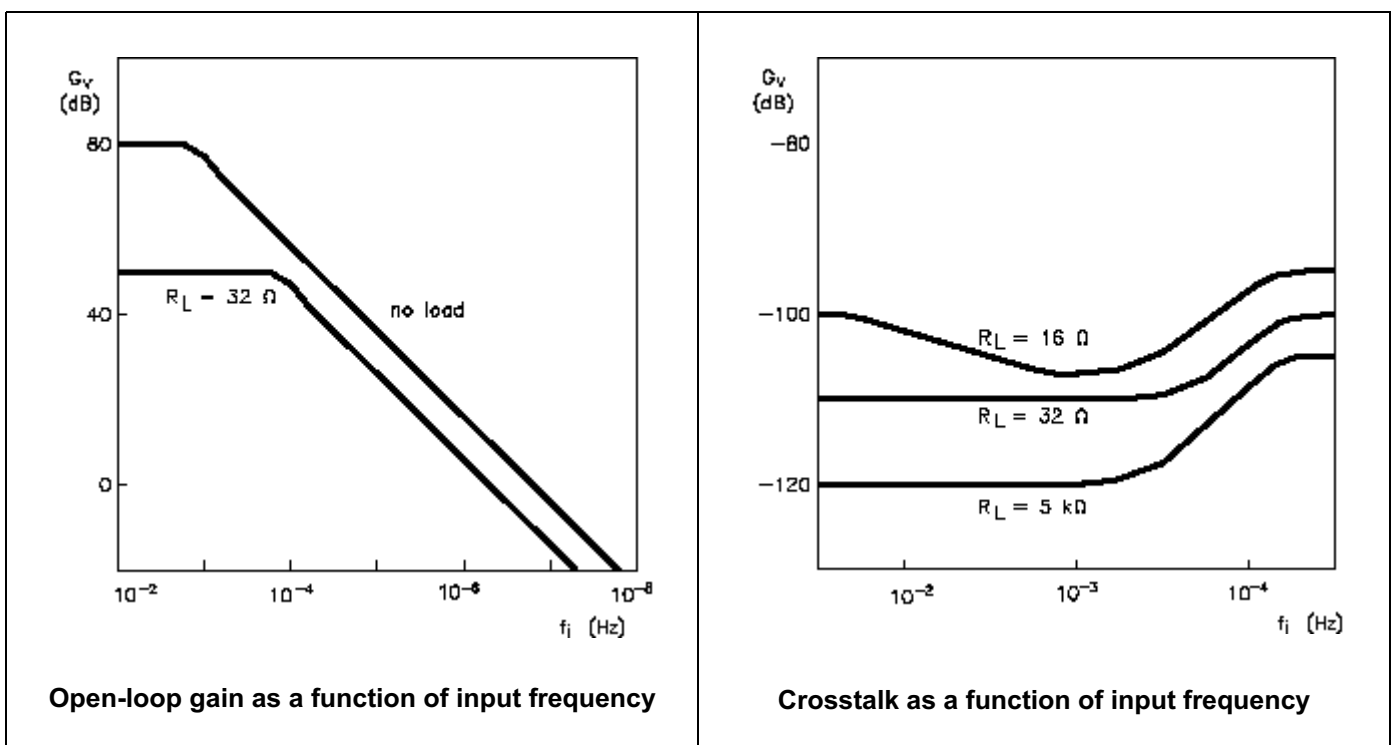

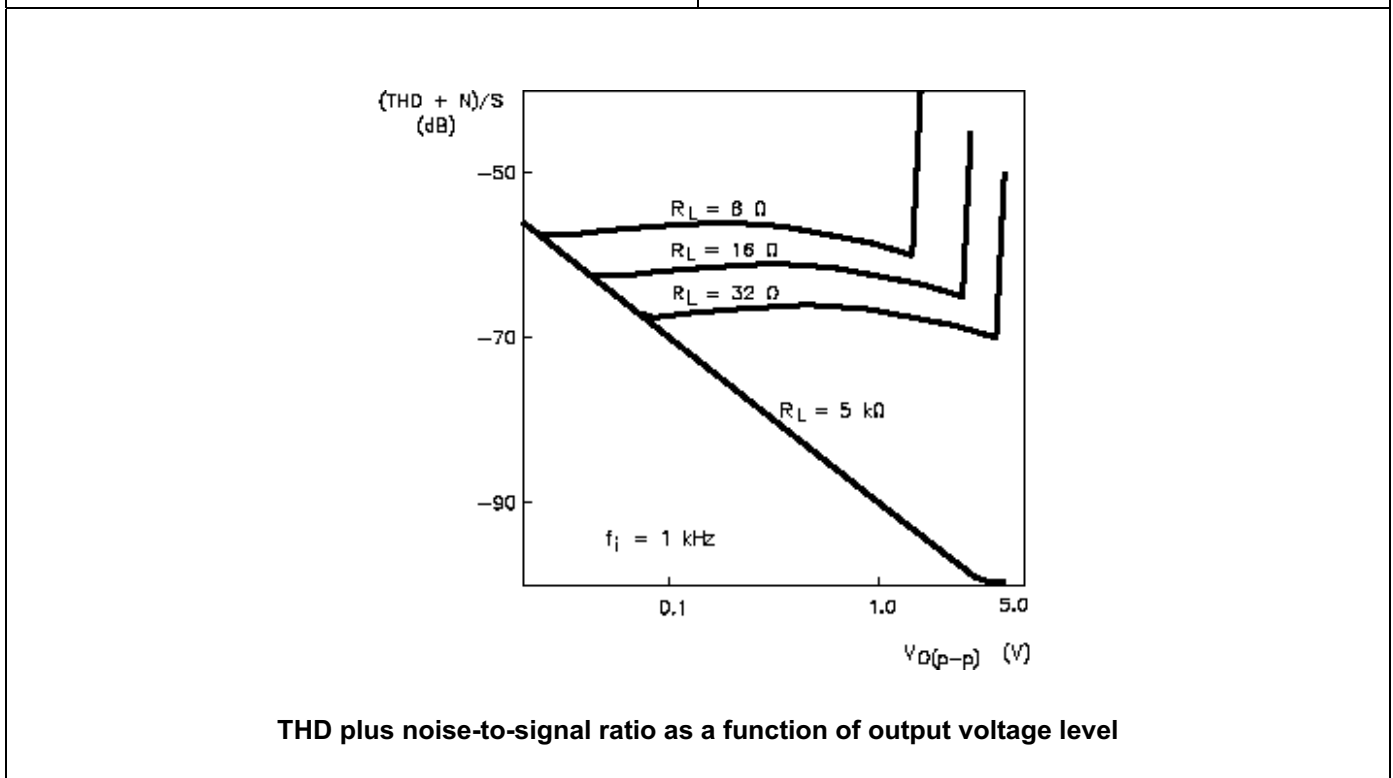
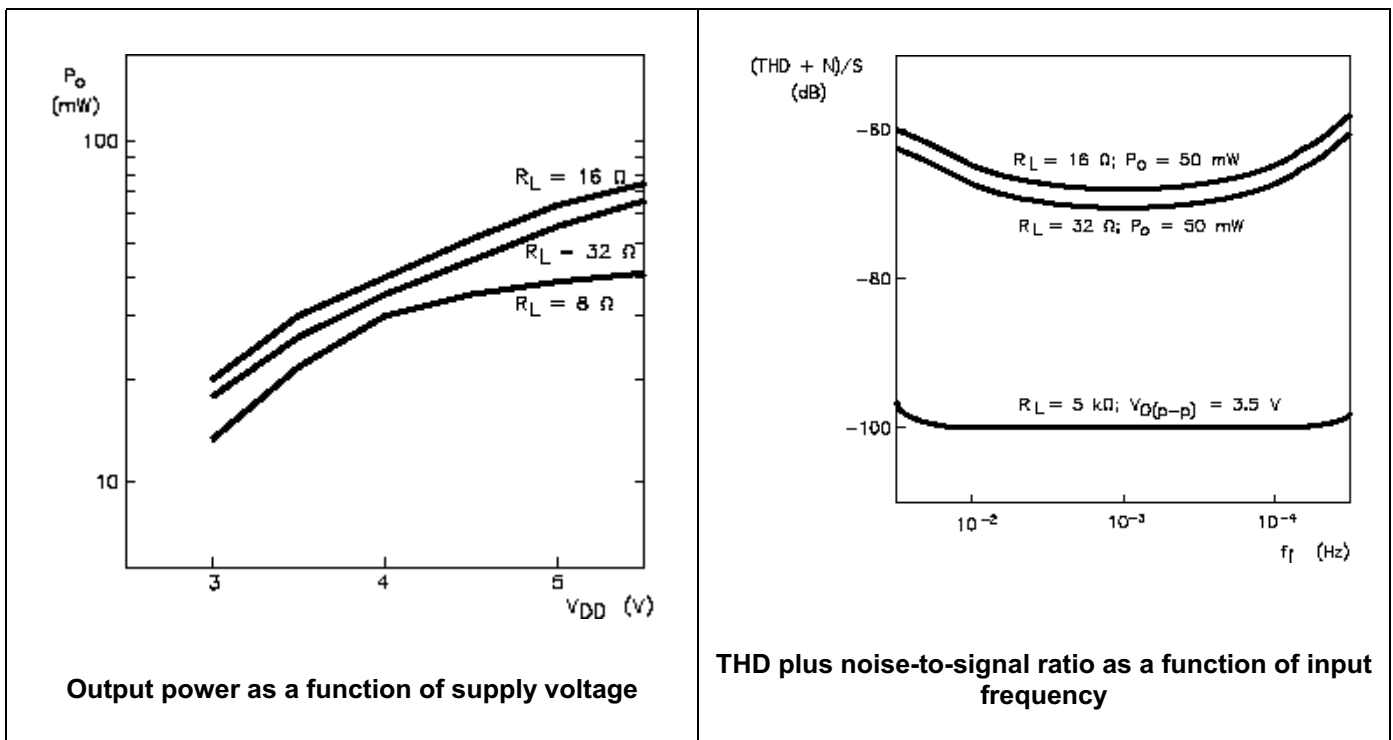

PACKAGE DIMENSION

8-PIN PDIP (P08)

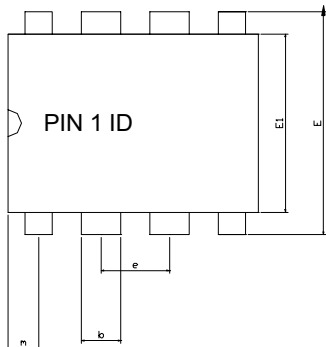

SYMBOLS	DIMENSIONS IN MILLIMETERS			DIMENSIONS IN INCHS		
	MIN	NOM	MAX	MIN	NOM	MAX
A	----	----	4.32	----	----	0.170
A1	0.38	----	----	0.015	----	----
b	1.40	----	1.65	0.055	----	0.065
b1	0.40	----	0.56	0.016	----	0.022
C	0.20	----	0.31	0.008	----	0.012
D	9.27	----	9.77	0.365	----	0.385
E	7.49	----	8.26	0.295	----	0.325
E1	6.09	----	6.61	0.240	----	0.260
e	----	2.54	----	----	0.100	----
L	3.18	----	----	0.125	----	----
m	0.50	----	----	0.02	----	----
θ	0	----	15	0	----	15

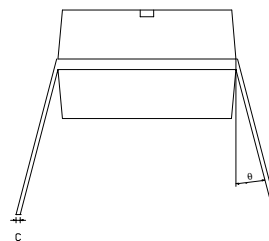
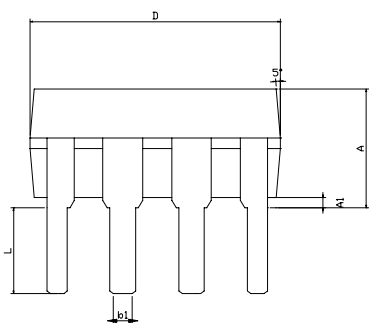

8-PIN SOP (S08)

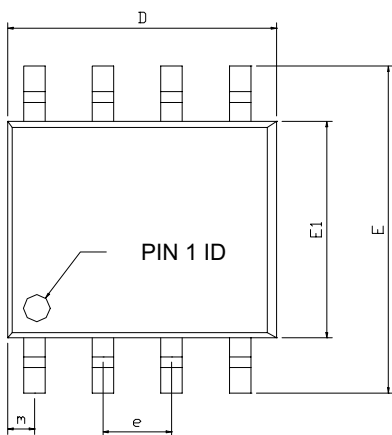

SYMBOLS	DIMENSIONS IN MILLIMETERS			DIMENSIONS IN INCHS		
	MIN	NOM	MAX	MIN	NOM	MAX
A1	0.10	----	0.25	0.004	----	0.010
A2	1.40	----	1.55	0.055	----	0.061
b	0.30	----	0.51	0.012	----	0.020
C	0.15	----	0.26	0.006	----	0.010
D	4.60	----	5.06	0.169	----	0.199
E	5.79	----	6.20	0.228	----	0.244
E1	3.76	----	4.01	0.148	----	0.158
e	----	1.27	----	----	0.050	----
L	0.38	----	0.69	0.015	----	0.035
m	0.43	----	0.69	0.017	----	0.027
θ	0°	----	8°	0°	----	8°

