



# CMD132P3

## 5-11 GHz Low Noise Amplifier

### Features

- ▶ Ultra low noise figure
- ▶ Low current consumption
- ▶ High gain broadband performance
- ▶ Single supply voltage: +3.6 V @ 30 mA
- ▶ Pb-free RoHs compliant 3x3 QFN package

### Description

The CMD132P3 is a broadband MMIC low noise amplifier housed in a leadless 3x3 mm plastic surface mount package. The CMD132P3 is ideally suited for microwave radios and C and X-band applications where small size and low power consumption are needed. The broadband device delivers greater than 20 dB of gain with a corresponding output 1 dB compression point of +10 dBm and a noise figure of 1.4 dB. The CMD132P3 is a 50 ohm matched design eliminating the need for external DC blocks and RF port matching. The CMD132P3 amplifier is the perfect alternative to costly hybrid amplifiers.

### Functional Block Diagram

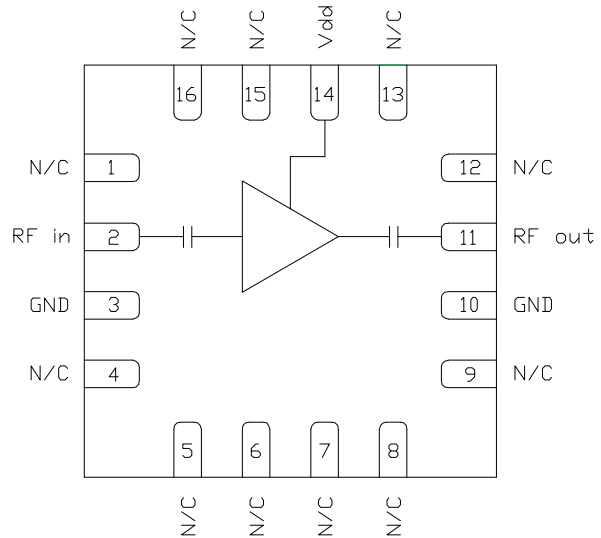

### Electrical Performance - $V_{dd} = 3.6 \text{ V}$ , $T_A = 25 \text{ }^\circ\text{C}$

Parameter	Min	Typ	Max	Units
Frequency Range	5 - 11			GHz
Gain		21		dB
Noise Figure		1.4		dB
Input Return Loss		10		dB
Output Return Loss		15		dB
Output P1dB		10		dBm
Supply Current		30		mA

ver 1.5 0516



# CMD132P3

## 5-11 GHz Low Noise Amplifier

### Specifications

#### Absolute Maximum Ratings

Parameter	Rating
Drain Voltage, Vdd	5.0 V
RF Input Power	+20 dBm
Channel Temperature, Tch	150 °C
Power Dissipation, Pdiss	367 mW
Thermal Resistance	177 °C/W
Operating Temperature	-40 to 85 °C
Storage Temperature	-55 to 150 °C

Operation of this device outside the maximum ratings may cause permanent damage.

#### Recommended Operating Conditions

Parameter	Min	Typ	Max	Units
Vdd	2.0	3.6	4.5	V
Idd		30		mA

Electrical performance is measured at specific test conditions. Electrical specifications are not guaranteed over all recommended operating conditions.

#### Electrical Specifications - V<sub>dd</sub> = 3.6 V, T<sub>A</sub> = 25 °C

Parameter	Min	Typ	Max	Min	Typ	Max	Units
Frequency Range	5 - 8.5			8.5 - 11			GHz
Gain	19	22	25	18	21	24	dB
Noise Figure		1.7	2.3		1.3	1.7	dB
Input Return Loss		8			10		dB
Output Return Loss		14			15		dB
Output P1dB		10			11		dBm
Output IP3		22			22.5		dBm
Supply Current	21	30	39	21	30	39	mA
Gain Temperature Coefficient		0.015			0.015		dB/°C
Noise Figure Temperature Coefficient		0.008			0.008		dB/°C

ver 1.5 0516

### Typical Performance

**Broadband Performance,  $V_{dd} = 3.6\text{ V}$ ,  $I_{dd} = 30\text{ mA}$ ,  $T_A = 25\text{ }^\circ\text{C}$**

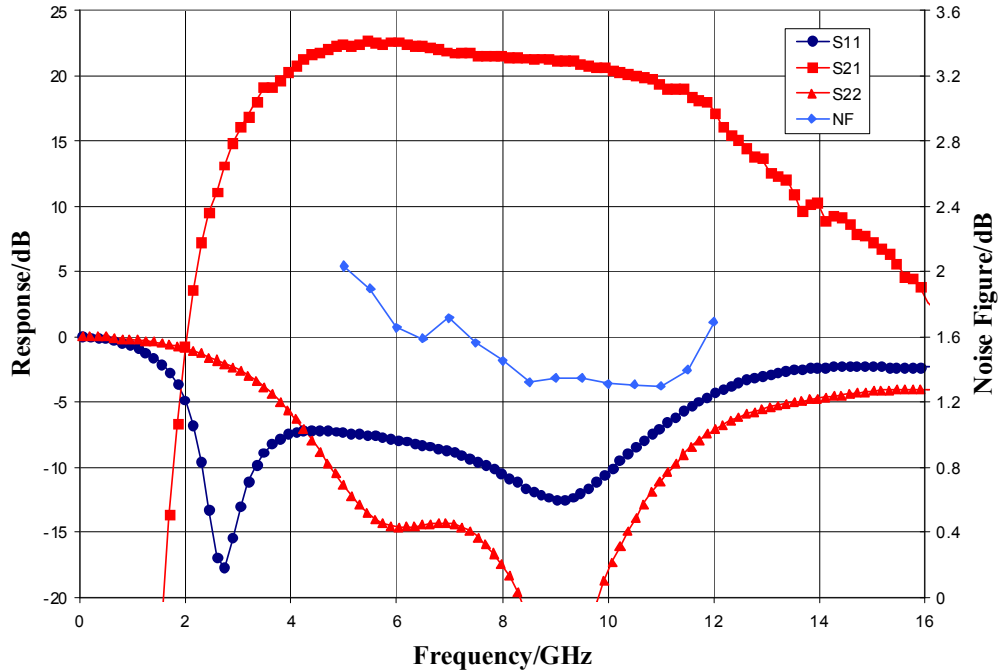

**Narrow-band Performance,  $V_{dd} = 3.6\text{ V}$ ,  $I_{dd} = 30\text{ mA}$ ,  $T_A = 25\text{ }^\circ\text{C}$**

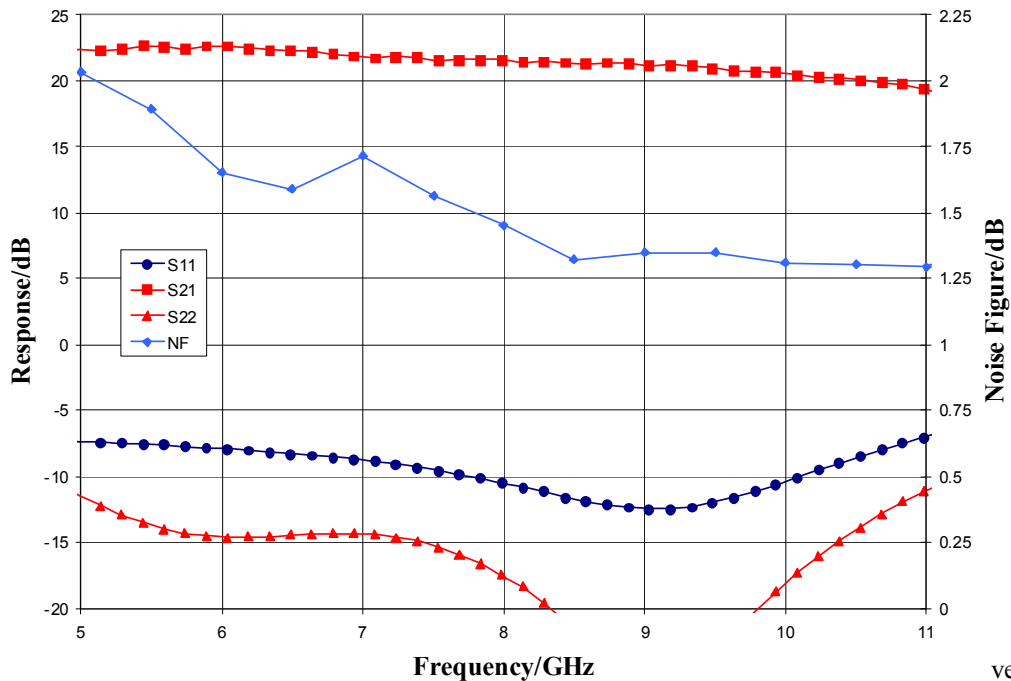

ver 1.5 0516

### Typical Performance

Gain vs. Temperature,  $V_{dd} = 3.6\text{ V}$

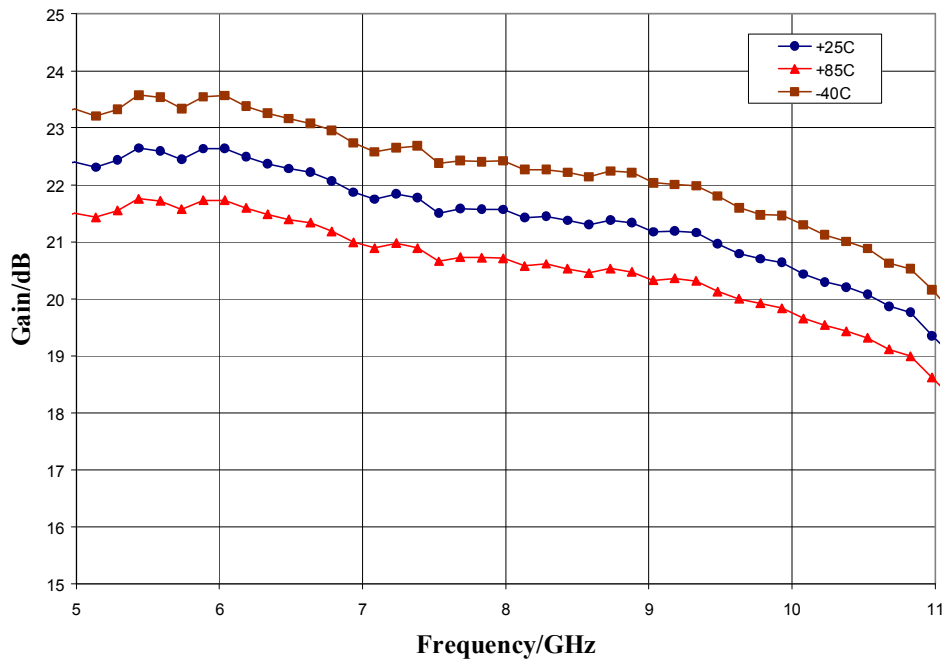

Noise Figure vs. Temperature,  $V_{dd} = 3.6\text{ V}$

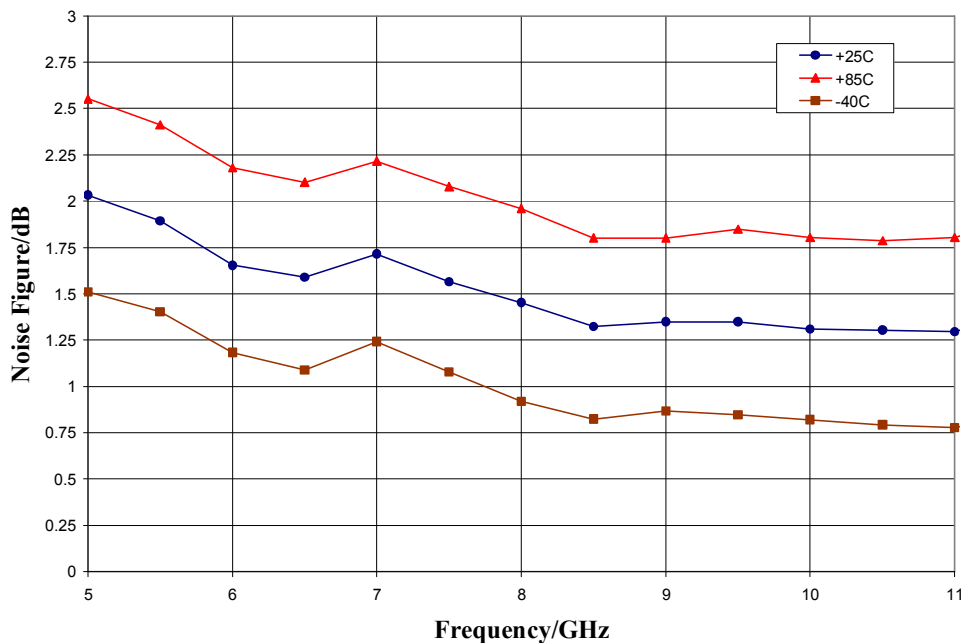

ver 1.5 0516

### Typical Performance

Output Power,  $V_{dd} = 3.6\text{ V}$ ,  $I_{dd} = 30\text{ mA}$ ,  $T_A = 25\text{ }^\circ\text{C}$

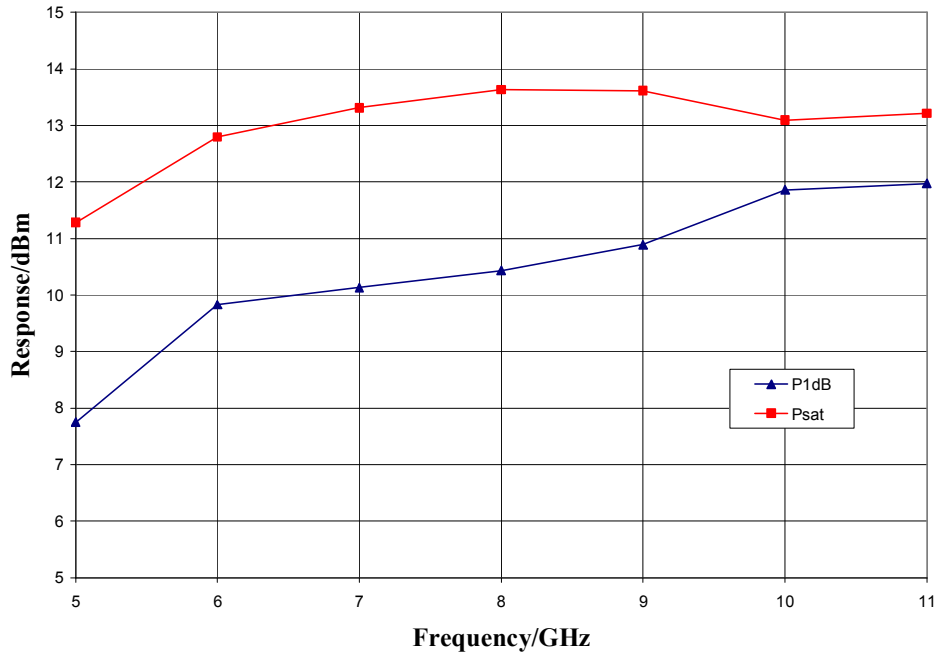

Output IP3,  $V_{dd} = 3.6\text{ V}$ ,  $I_{dd} = 30\text{ mA}$ ,  $T_A = 25\text{ }^\circ\text{C}$

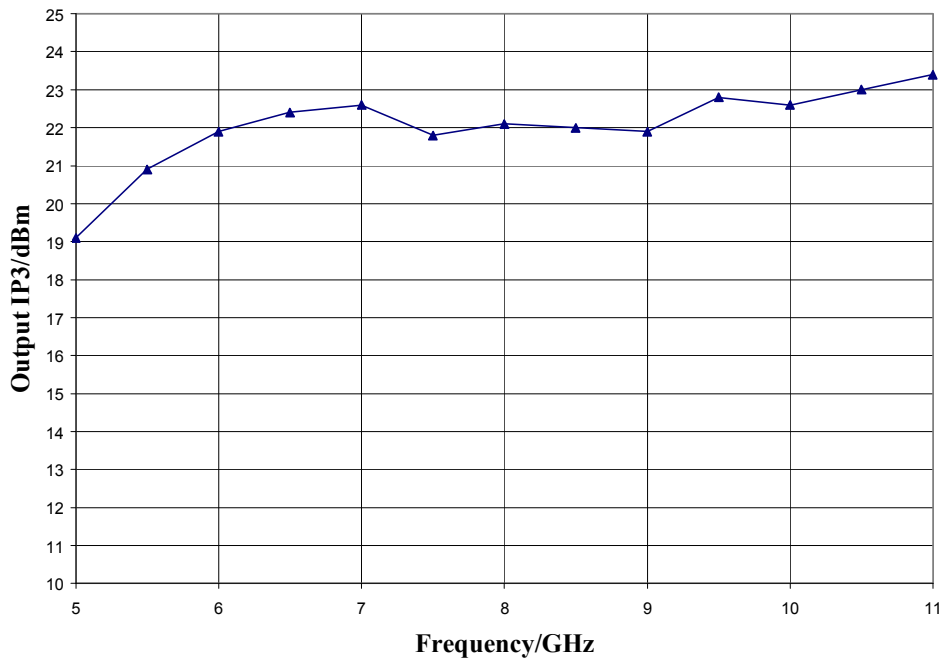

ver 1.5 0516

### Mechanical Information

#### Package Information and Dimensions

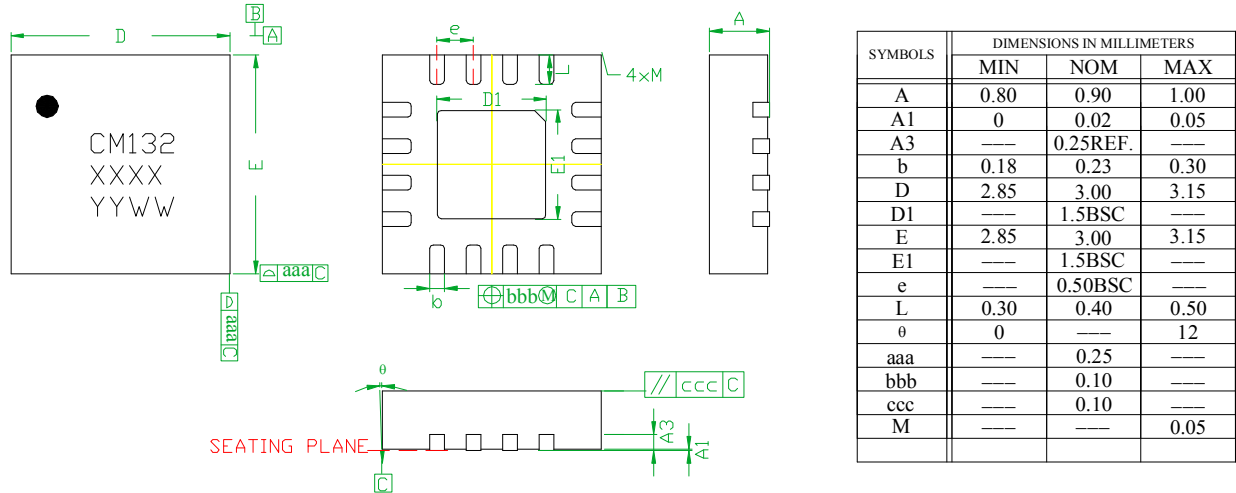

- NOTES:
1. DIMENSIONS ARE IN MILLIMETERS
  2. RoHS COMPLIANT MOLD COMPOUND
  3. LEADFRAME MATERIAL: COPPER ALLOY
  4. LEAD FINISH: 100% MATTE Sn
  5. INDICATED DIMENSION/TOLERANCE APPLIES TO LEADS AND EXPOSED PAD

#### Recommended PCB Land Pattern

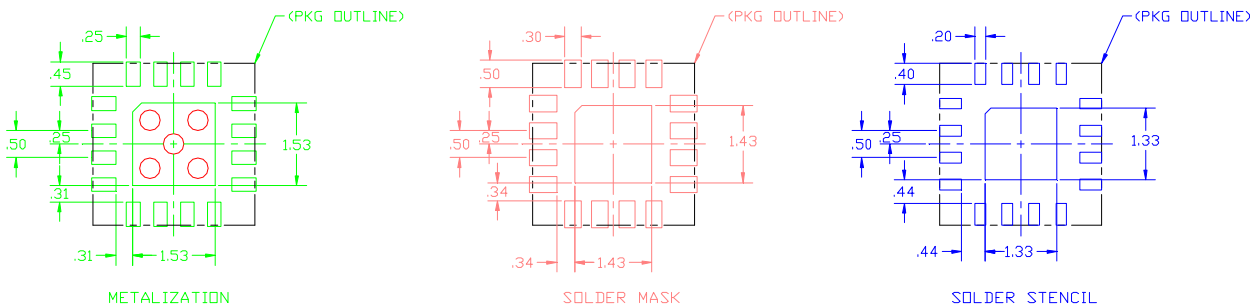

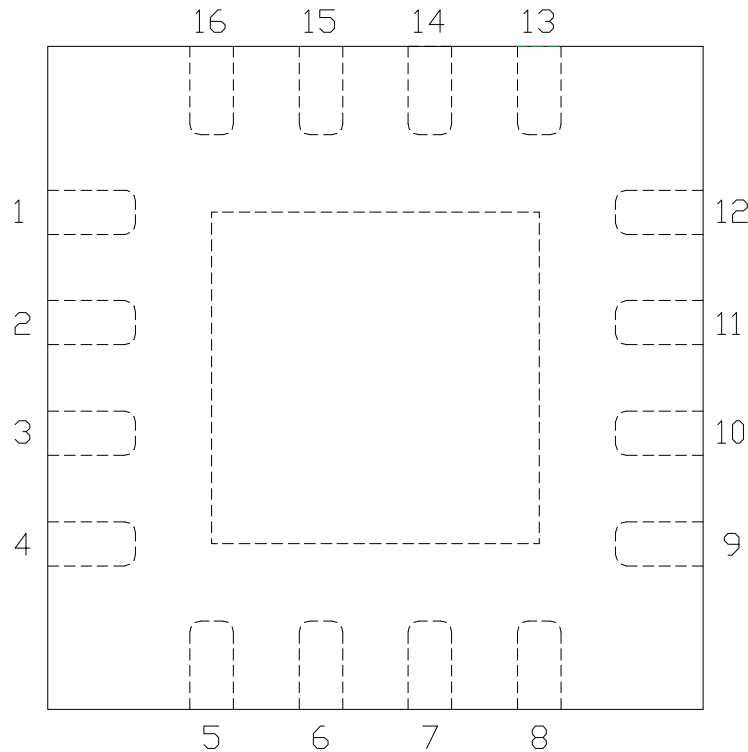

### Pin Description

#### Pin Diagram

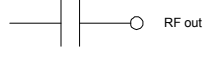
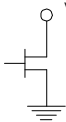

#### Functional Description

Pin	Function	Description	Schematic
2	RF in	DC blocked and 50 ohm matched	
11	RF out	DC blocked and 50 ohm matched	
14	Vdd	Power supply voltage Decoupling and bypass caps required	
3,10 and die paddle	Ground	Connect to RF / DC ground	

ver 1.5 0516

### Applications Information

#### Application Circuit

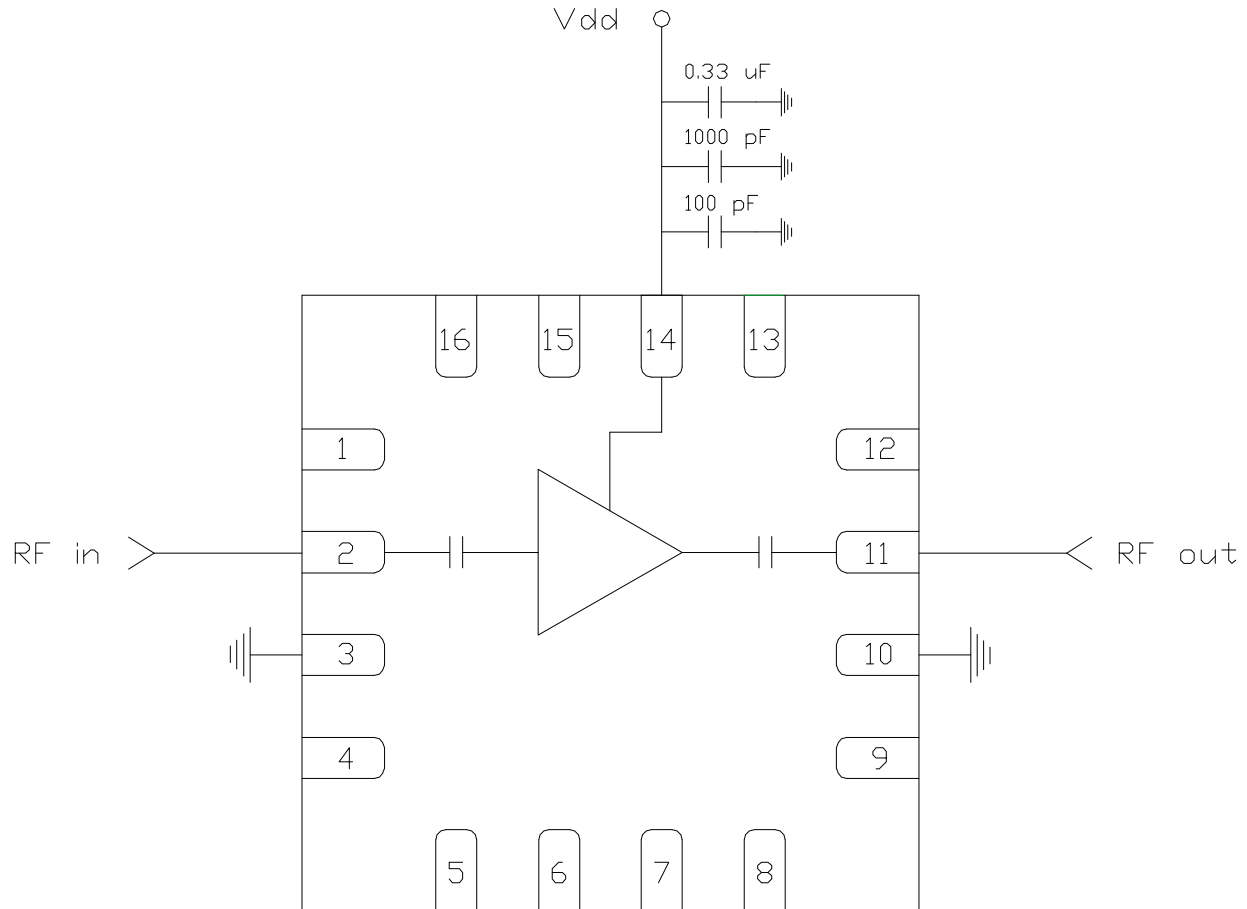

#### Biasing and Operation

The CMD132P3 is biased with a single 3.6 V positive drain supply.

RF power can be applied at any time.

**GaAs MMIC devices are susceptible to damage from Electrostatic Discharge. Proper precautions should be observed during handling, assembly and test.**

ver 1.5 0516



### Applications Information

#### Evaluation Board

The circuit board shown has been developed for optimized assembly at CMDS. A sufficient number of via holes should be used to connect the top and bottom ground planes. As surface mount processes vary, careful process development is recommended.

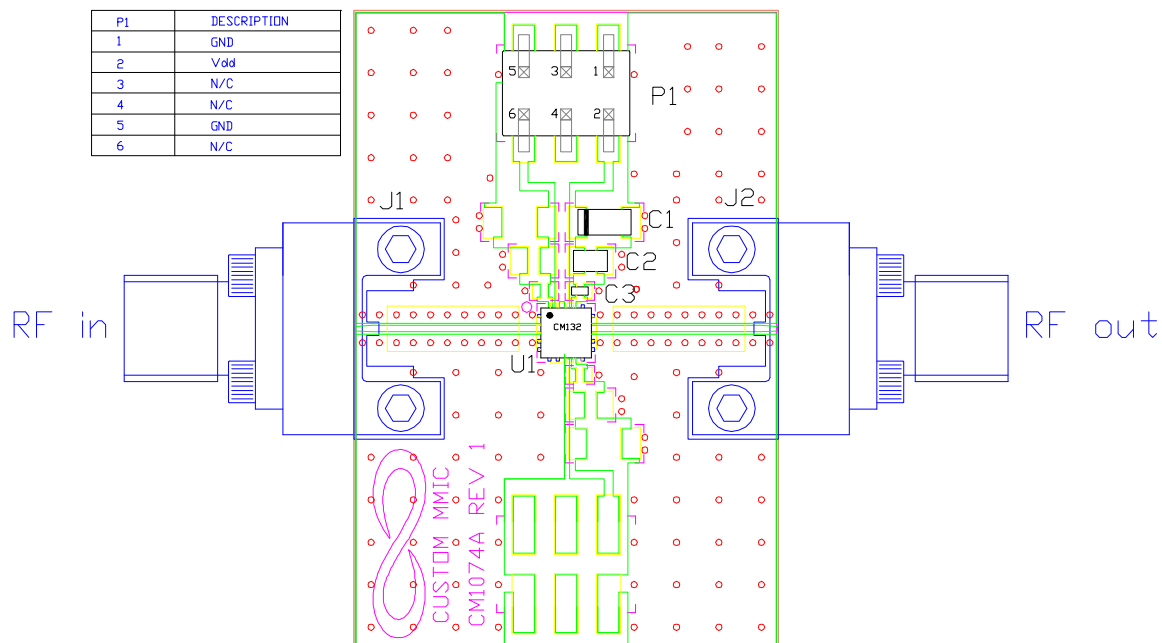

#### Bill of Material

Designator	Value	Description
J1, J2		SMA End Launch Connector
P1		6 Pin Header
C1	0.33 $\mu$ F	Capacitor, Tantalum
C2	1000 pF	Capacitor, 0603
C3	100 pF	Capacitor, 0402
U1		CMD132P3 Low Noise Amplifier
PCB		CM1074A Evaluation PCB

ver 1.5 0516