

Features

- ▶ Ultra low noise figure
- ▶ High gain broadband performance
- ▶ Single supply voltage: +4.0 V @ 75 mA
- ▶ Small die size

Description

The CMD185 is a broadband MMIC low noise amplifier ideally suited for EW and communications systems where small size and low power consumption are needed. The broadband device delivers greater than 15 dB of gain with a corresponding output 1 dB compression point of +15 dBm and a noise figure of 1.9 dB. The CMD185 is a 50 ohm matched design eliminating the need for external DC blocks and RF port matching. The CMD185 offers full passivation for increased reliability and moisture protection.

Functional Block Diagram

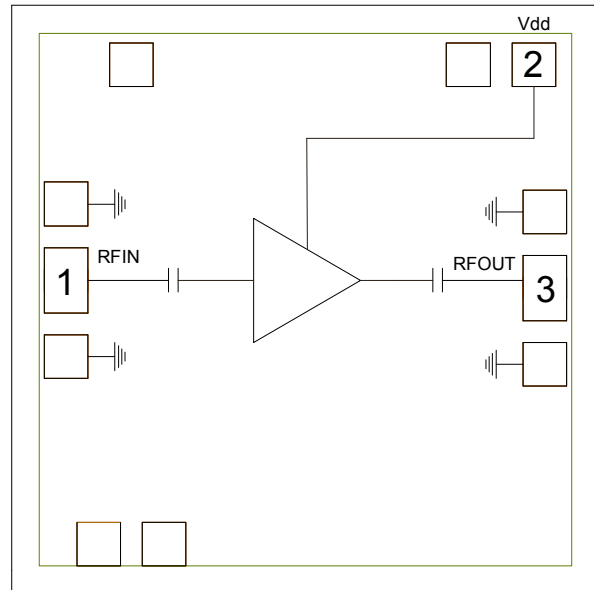

Electrical Performance - $V_{dd} = 4.0\text{ V}$, $T_A = 25\text{ }^\circ\text{C}$, $F = 6\text{ GHz}$

Parameter	Min	Typ	Max	Units
Frequency Range		4 - 8		GHz
Gain		15.5		dB
Noise Figure		1.9		dB
Input Return Loss		10		dB
Output Return Loss		17		dB
Output P1dB		15		dBm
Supply Current		75		mA

Specifications

Absolute Maximum Ratings

Parameter	Rating
Drain Voltage, Vdd	5 V
RF Input Power	+20 dBm
Channel Temperature, Tch	150 °C
Power Dissipation, Pdiss	529 mW
Thermal Resistance	123 °C/W
Operating Temperature	-40 to 85 °C
Storage Temperature	-55 to 150 °C

Operation of this device outside the maximum ratings may cause permanent damage.

Recommended Operating Conditions

Parameter	Min	Typ	Max	Units
Vdd	2.0	4.0	5.0	V
Idd		75		mA

Electrical performance is measured at specific test conditions. Electrical specifications are not guaranteed over all recommended operating conditions.

Electrical Specifications - V_{dd} = 4.0 V, T_A = 25 °C

Parameter	Min	Typ	Max	Min	Typ	Max	Units
Frequency Range	4 - 6			6 - 8			GHz
Gain	13.5	15.5	17.5	13	15	17.5	dB
Noise Figure		2	2.8		1.5	2.7	dB
Input Return Loss		10			13		dB
Output Return Loss		18			13		dB
Output P1dB		14			16.5		dBm
Output IP3		28			29.5		dBm
Supply Current	53	75	97	53	75	97	mA
Gain Temperature Coefficient		0.009			0.009		dB/°C
Noise Figure Temperature Coefficient		0.009			0.009		dB/°C

ver 1.0 0716

Typical Performance

Broadband Performance, $V_{dd} = 4.0 \text{ V}$, $I_{dd} = 75 \text{ mA}$, $T_A = 25 \text{ }^\circ\text{C}$

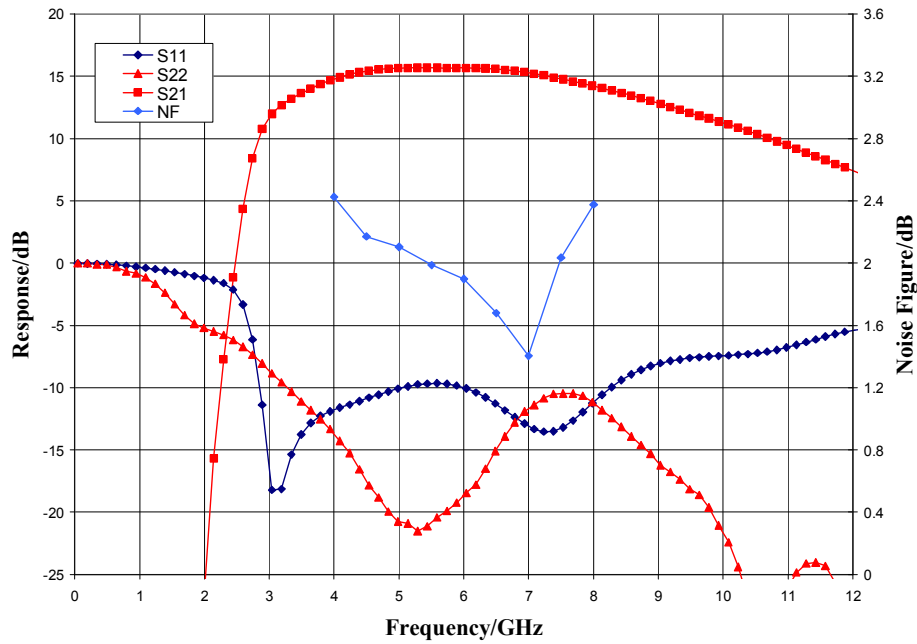

Narrow-band Performance, $V_{dd} = 4.0 \text{ V}$, $I_{dd} = 75 \text{ mA}$, $T_A = 25 \text{ }^\circ\text{C}$

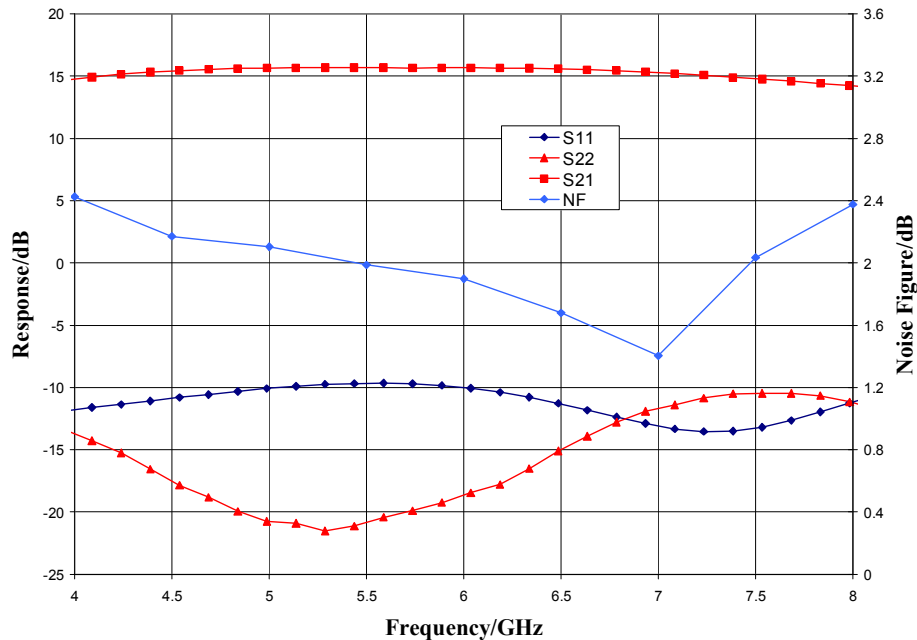

ver 1.0 0716

Typical Performance

Gain vs. Temperature, $V_{dd} = 4.0\text{ V}$

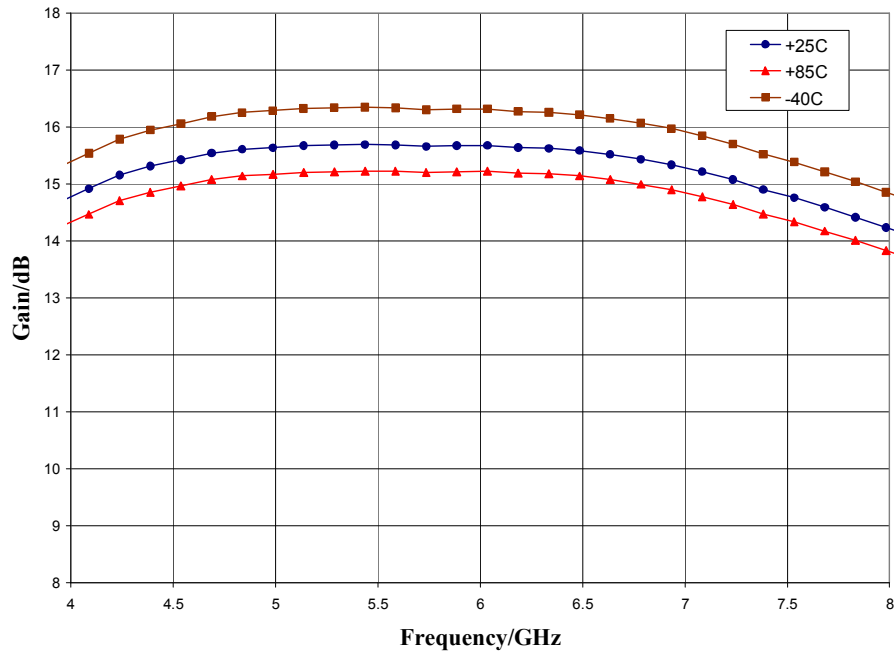

Noise Figure vs. Temperature, $V_{dd} = 4.0\text{ V}$

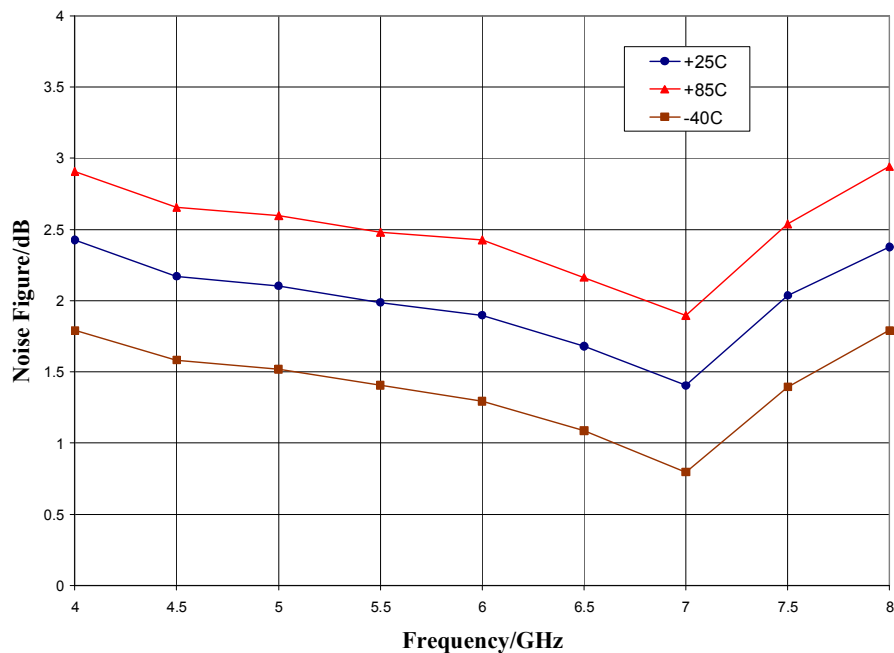

ver 1.0 0716

Typical Performance

Noise Figure, $V_{dd} = 3.3\text{ V}, 4.0\text{V}, 5.0\text{V}, T_A = 25\text{ }^\circ\text{C}$

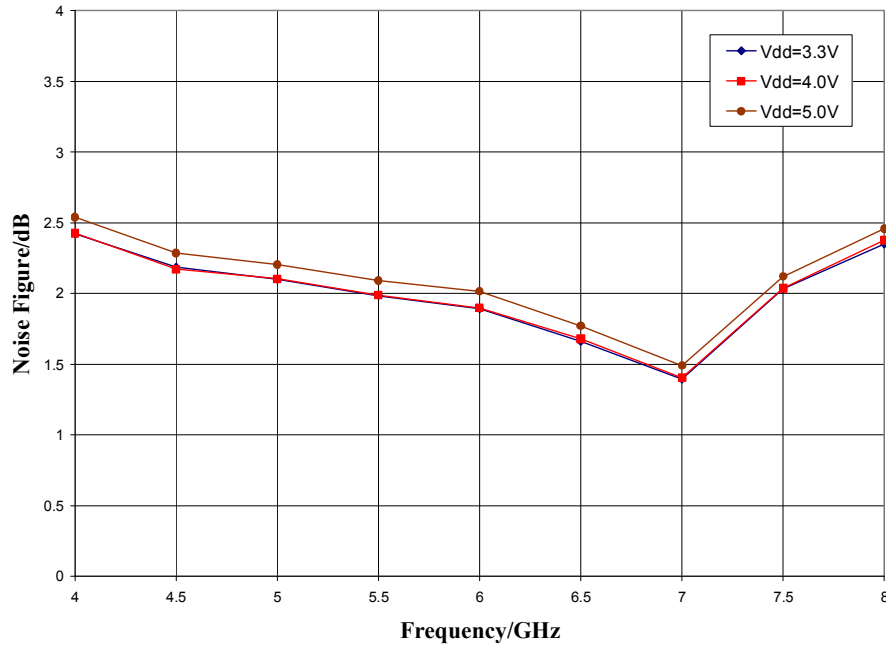

P1dB vs. Temperature, $V_{dd} = 4.0\text{ V}$

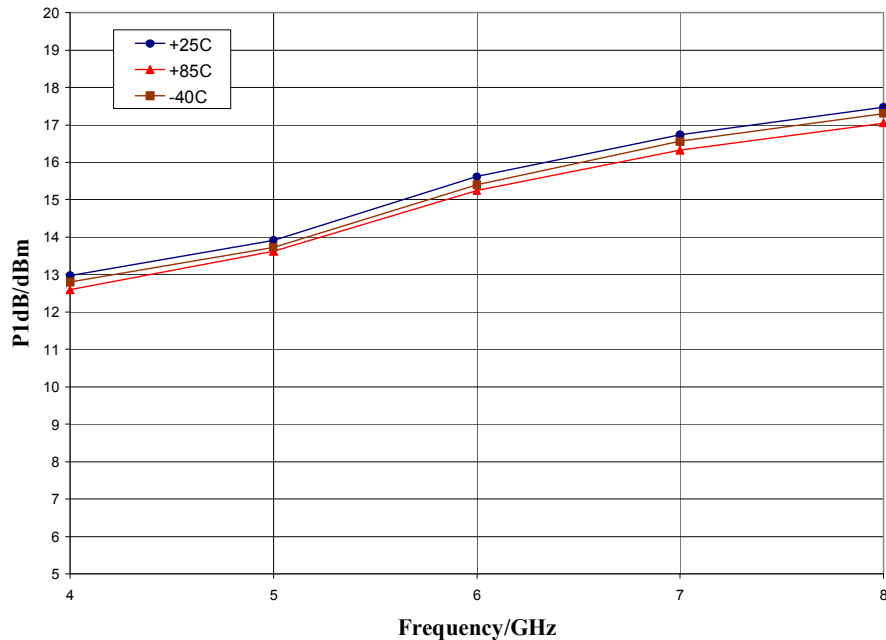

ver 1.0 0716

Typical Performance

P1dB, $V_{dd} = 3.3V, 4.0V, 5.0V, T_A = 25^\circ C$

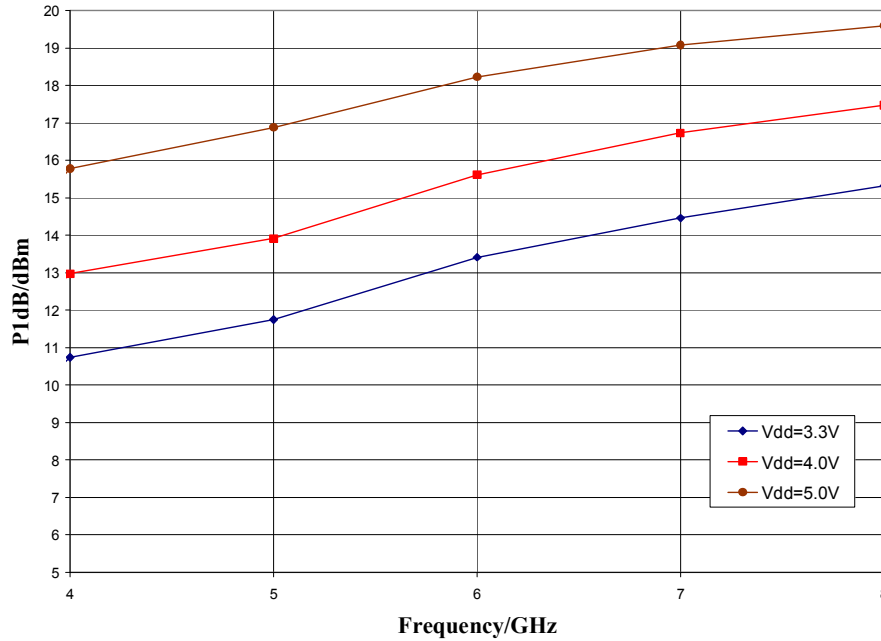

Output IP3, $V_{dd} = 3.3V, 4.0V, 5.0V, T_A = 25^\circ C$

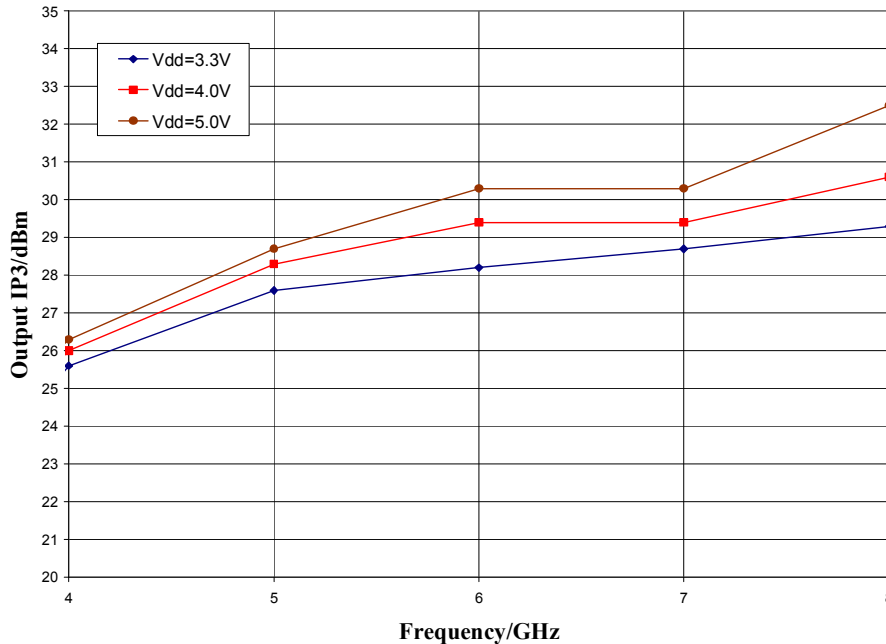

ver 1.0 0716

Mechanical Information

Die Outline (all dimensions in microns)

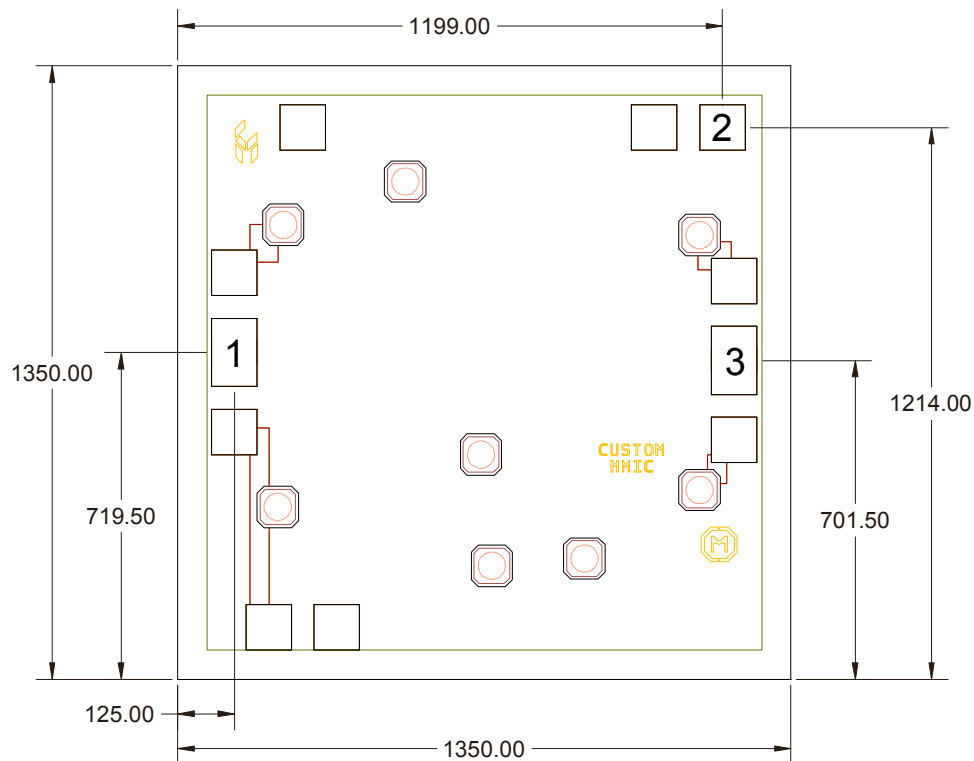

Notes:



1. No connection required for unlabeled pads
2. Backside is RF and DC ground
3. Backside and bond pad metal: Gold
4. Die is 85 microns thick
5. DC bond pads are 100 microns square
6. RF bond pads are 100 microns x 150 microns

Pad Description

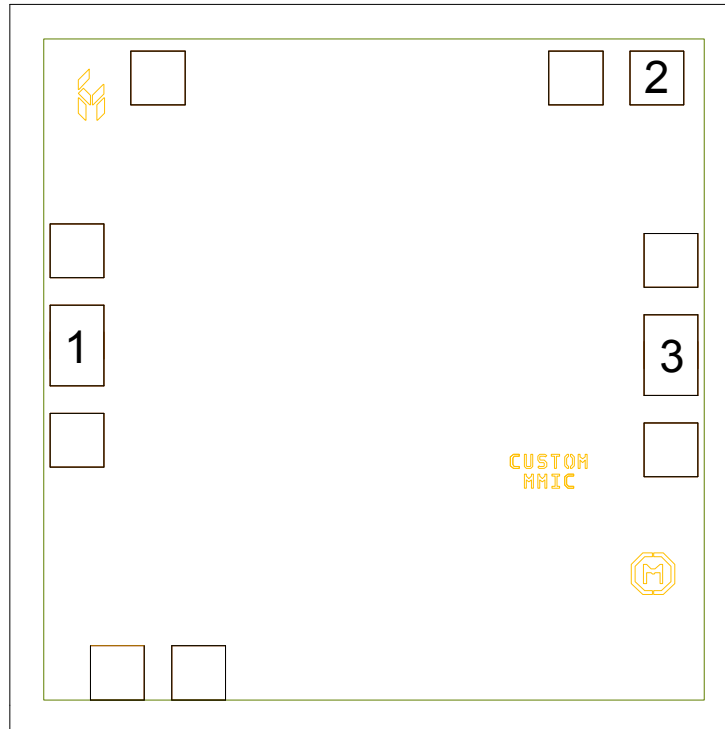
Pad Diagram

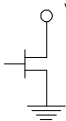
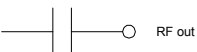

Functional Description

Pin	Function	Description	Schematic
1	RF in	DC blocked and 50 ohm matched	
2	Vdd	Power supply voltage Decoupling and bypass caps required	
3	RF out	DC blocked and 50 ohm matched	
Backside	Ground	Connect to RF / DC ground	

ver 1.0 0716

Applications Information

Assembly Guidelines

The backside of the CMD185 is RF ground. Die attach may be accomplished with either electrically and thermally conductive epoxy or eutectic attach. Standard assembly procedures should be followed for high frequency devices. The top surface of the semiconductor should be made planar to the adjacent RF transmission lines, and the RF decoupling capacitors placed in close proximity to the DC connections on chip.

RF connections should be made as short as possible to reduce the inductive effect of the bond wire. Use of a 0.8 mil thermosonic wedge bonding is highly recommended as the loop height will be minimized. The RF input and output require a single bond wire as shown.

The semiconductor is 85 um thick and should be handled by the sides of the die or with a custom collet. Do not make contact directly with the die surface as this will damage the monolithic circuitry. Handle with care.

Assembly Diagram

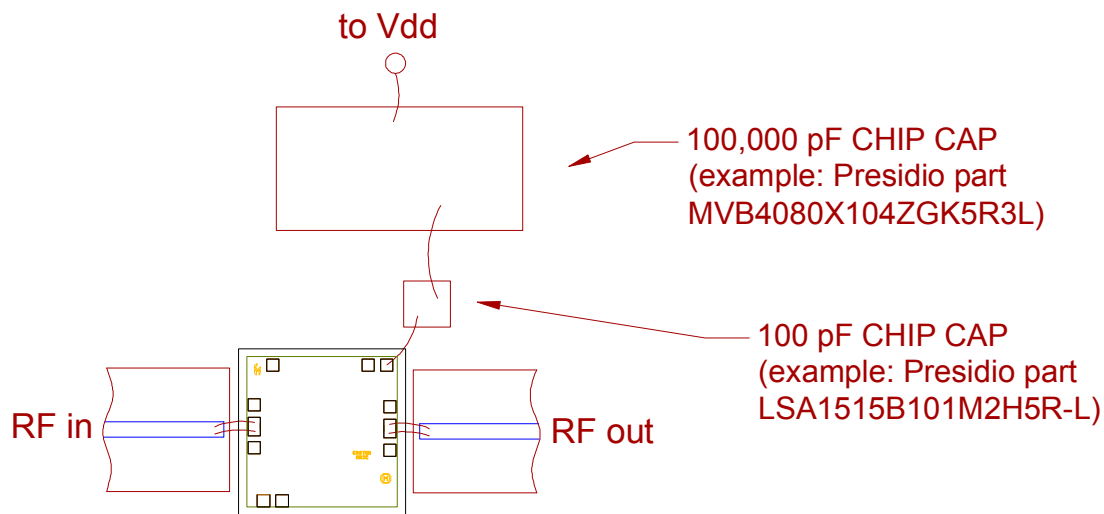

Biasing and Operation

The CMD185P3 is biased with a single 4.0 V positive drain supply.

RF power can be applied at any time.

GaAs MMIC devices are susceptible to damage from Electrostatic Discharge. Proper precautions should be observed during handling, assembly and test.