

Features

- ▶ Broadband performance
- ▶ Low loss
- ▶ High isolation
- ▶ Fast switching speed
- ▶ Small die size

Description

The CMD215 is a general purpose broadband high isolation reflective MMIC SPDT switch in die form. Covering DC to 40 GHz, the CMD215 features a low insertion loss of 2.3 dB and high isolation of 36 dB at 20 GHz. The CMD215 operates using complementary control voltage logic lines of 0/-5 V and requires no bias supply.

Functional Block Diagram

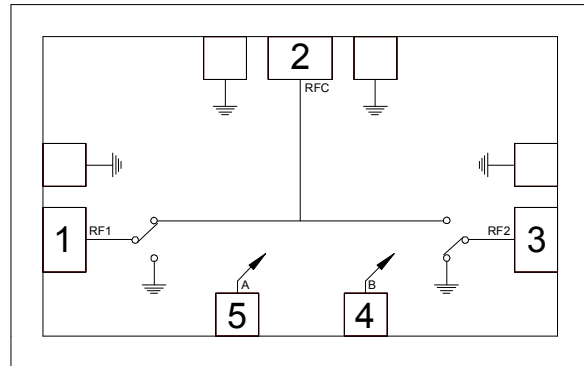

Electrical Performance - $V_{ctl} = 0/-5\text{ V}$, $T_A = 25\text{ }^\circ\text{C}$, $F = 20\text{ GHz}$

Parameter	Min	Typ	Max	Units
Frequency Range	DC - 40			GHz
Insertion Loss		2.3		dB
Isolation		36		dB
Return Loss - On State		16		dB
Input P1dB		19		dBm
Input P0.1dB		17		dBm
Input IP3		30		dBm
Switching Speed		4		ns

ver 1.0 0916

Specifications

Absolute Maximum Ratings

Parameter	Rating
RF Input Power	+27 dBm
Control Voltage Range (A,B)	+0.5V to -7.5V
Channel Temperature, T _{ch}	150 °C
Operating Temperature	-55 to 85 °C
Storage Temperature	-55 to 150 °C

Operation of this device outside the maximum ratings may cause permanent damage.

Control Voltages

State	Bias Condition
Low	0 to -0.5V @ 1 uA Typ
High	-3V @ 1 uA Typ to -7V @ 6 uA Typ

Truth Table

Control Input		Signal Path State	
A	B	RFC to RF1	RFC to RF2
High	Low	Off	On
Low	High	On	Off

Electrical Specifications - V_{ctl} = 0/-5 V, T_A = 25 °C

Parameter	Min	Typ	Max	Min	Typ	Max	Min	Typ	Max	Units
Frequency Range	DC - 18			18 - 26			26 - 40			GHz
Insertion Loss		2	2.4		2	2.6		3	3.6	dB
Isolation	38	45		30	36		31	37		dB
Return Loss - On State		13			14			10		dB
Input P1dB		17			20			22		dBm
Input P0.1dB		15			17			20		dBm
Input IP3		29			31			32		dBm
Switching Speed		4			4			4		ns

ver 1.0 0916

Typical Performance

Insertion Loss vs. Temperature

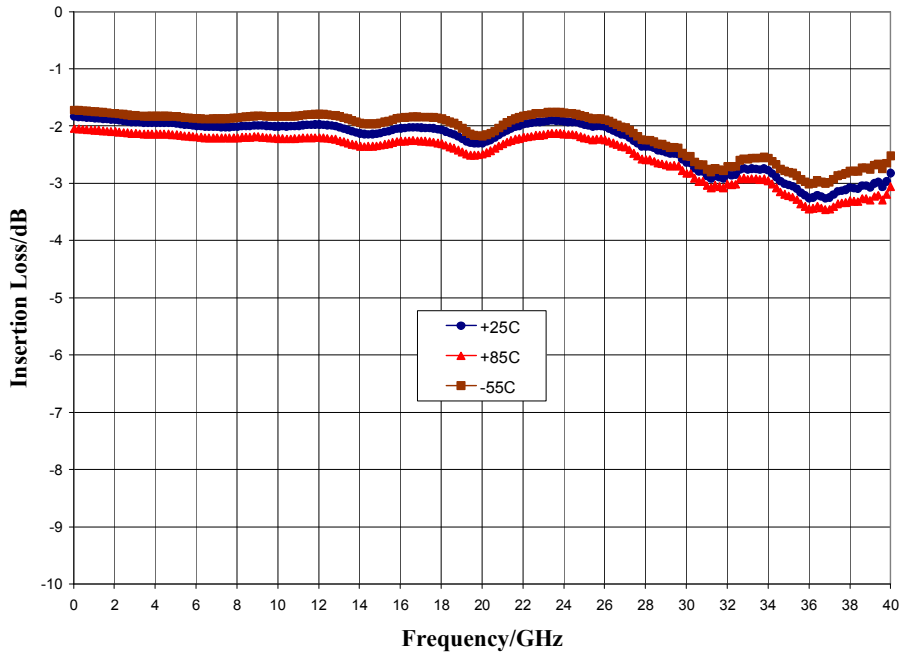

Return Loss

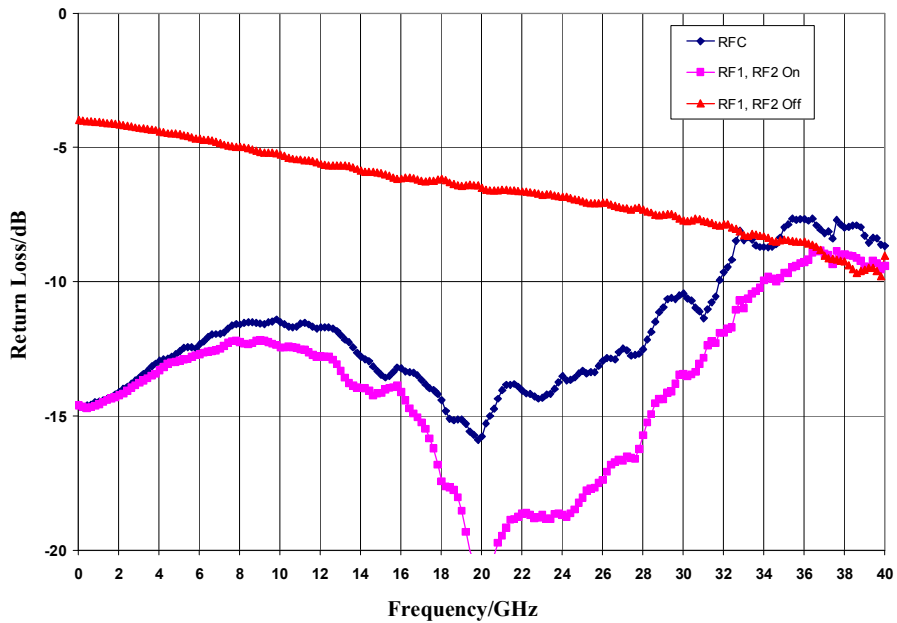

ver 1.0 0916

Typical Performance

Isolation Between Ports RFC and RF1/RF2

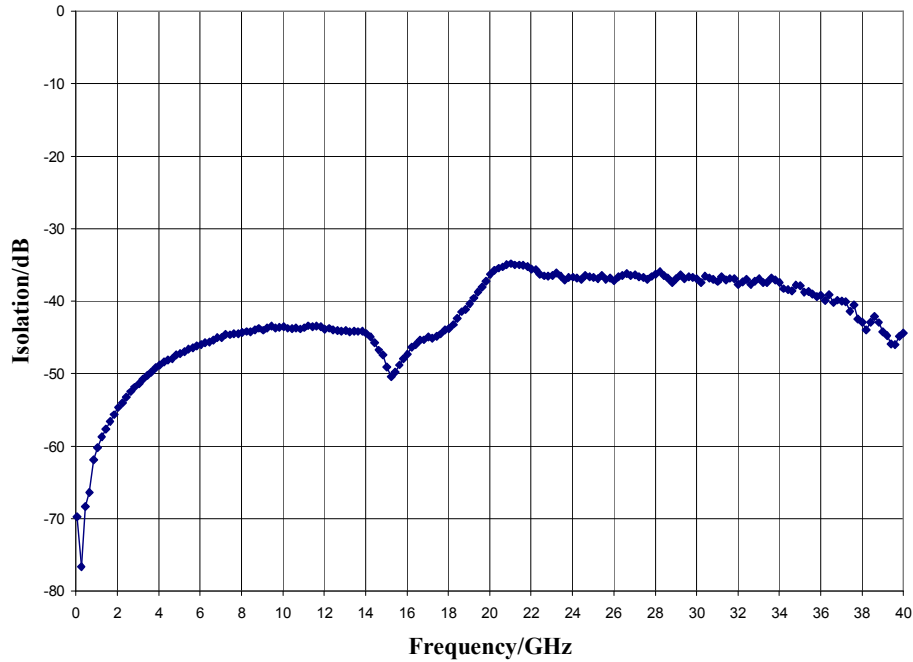

Input P1dB and P0.1dB Compression Point

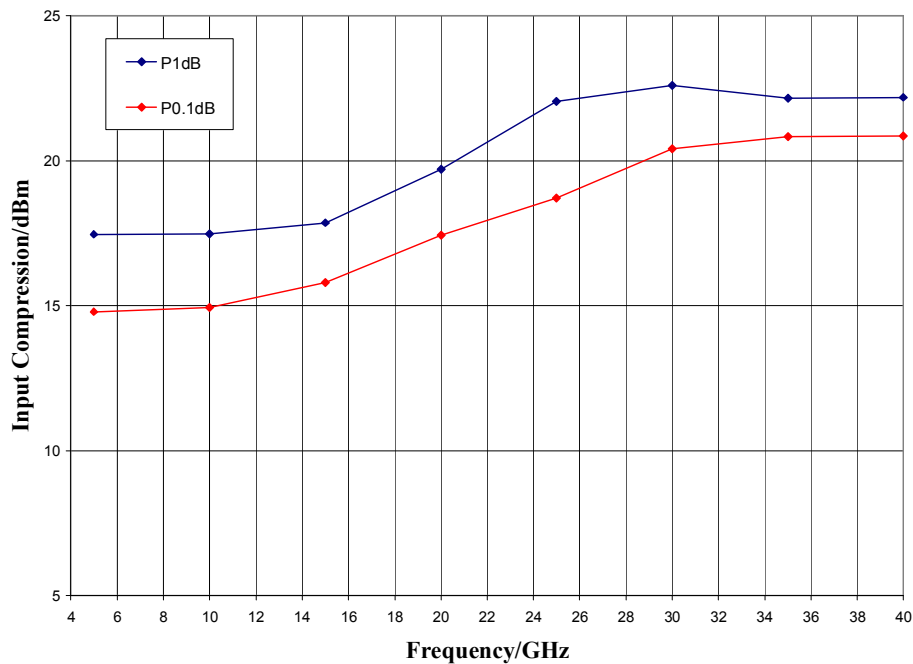

ver 1.0 0916

Typical Performance

Input Third Order Intercept Point

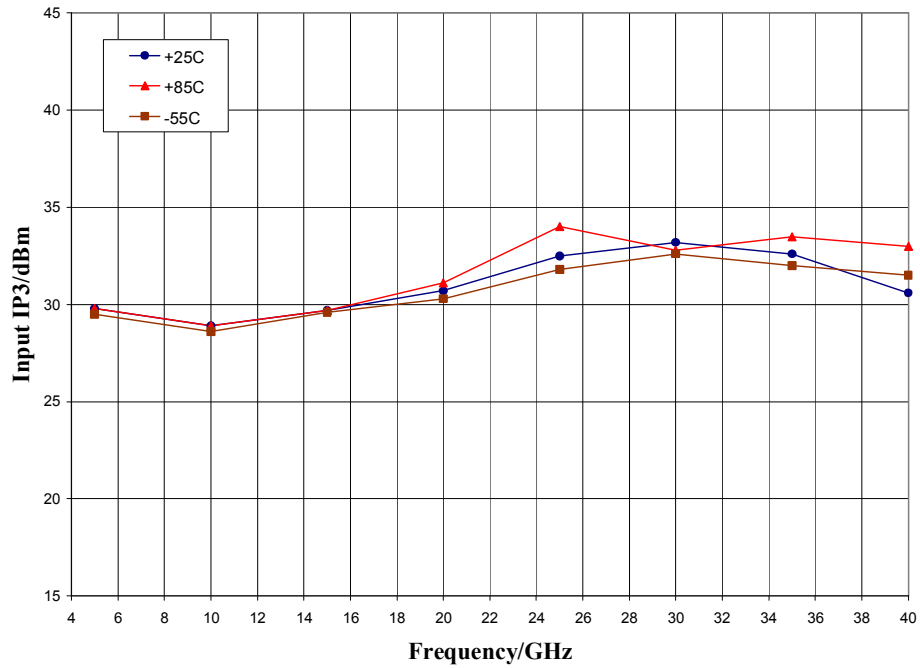

Mechanical Information

Die Outline (all dimensions in microns)

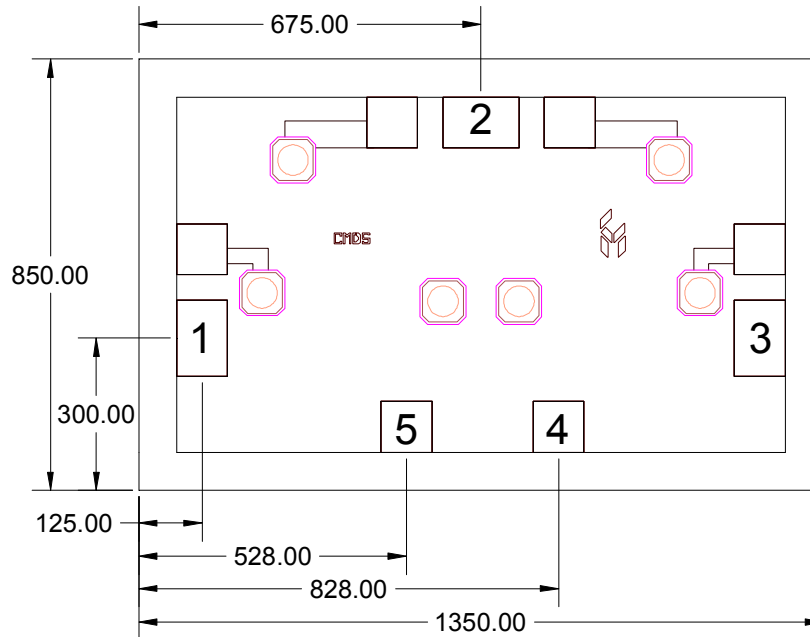

Notes:



1. No connection required for unlabeled pads
2. Backside is RF and DC ground
3. Backside and bond pad metal: Gold
4. Die is 85 microns thick
5. DC bond pads are 100 microns square
6. RF bond pads are 100 x 150 micron

Pad Description

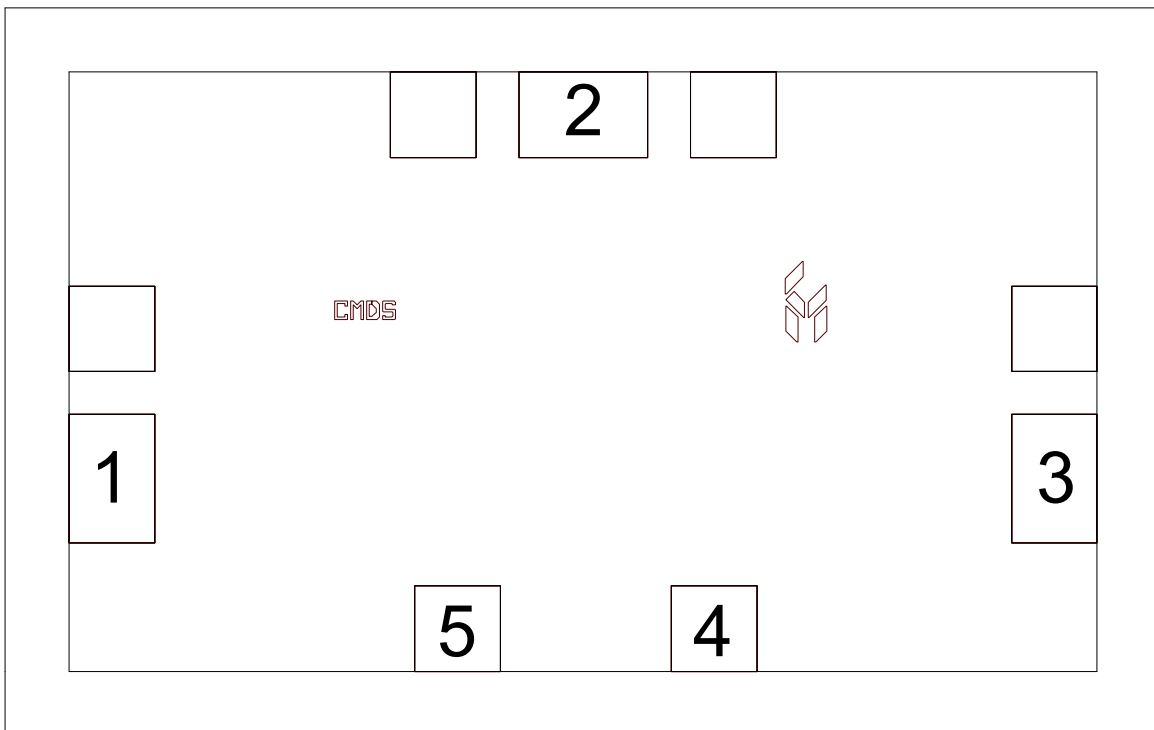
Pad Diagram

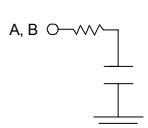

Functional Description

Pin	Function	Description	Schematic
1, 2, 3	RF1, RFC, RF2	These pins are DC coupled and matched to 50 Ohm. Blocking capacitors are required if RF line potential is not equal to 0V	
4	CTRLB	See truth table and control voltage table	
5	CTRLA	See truth table and control voltage table	
Backside	Ground	Connect to RF / DC ground	

ver 1.0 0916

Applications Information

Suggested Driver Circuit

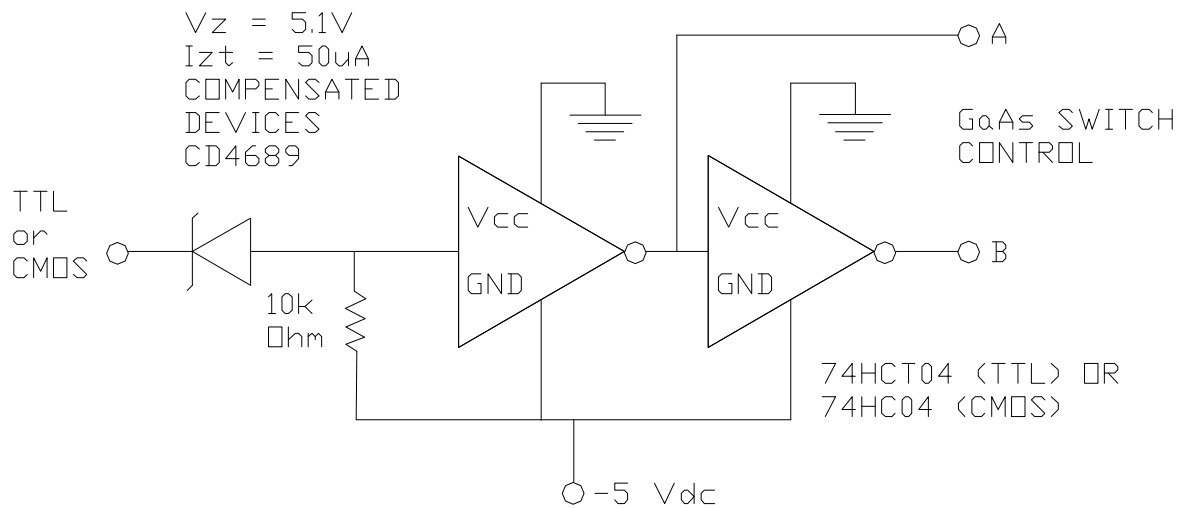

GaAs MMIC devices are susceptible to damage from Electrostatic Discharge. Proper precautions should be observed during handling, assembly and test.

ver 1.0 0916

Applications Information

Assembly Guidelines

The backside of the CMD215 is RF ground. Die attach should be accomplished with electrically and thermally conductive epoxy only. Eutectic attach is not recommended. Standard assembly procedures should be followed for high frequency devices. The top surface of the semiconductor should be made planar to the adjacent RF transmission lines, and the RF decoupling capacitors placed in close proximity to the DC connections on chip.

RF connections should be made as short as possible to reduce the inductive effect of the bond wire. Use of a 0.8 mil thermosonic wedge bonding is highly recommended as the loop height will be minimized. The RF inputs and outputs require a double bond wire as shown.

The semiconductor is 85 um thick and should be handled by the sides of the die or with a custom collet. Do not make contact directly with the die surface as this will damage the monolithic circuitry. Handle with care.

Assembly Diagram

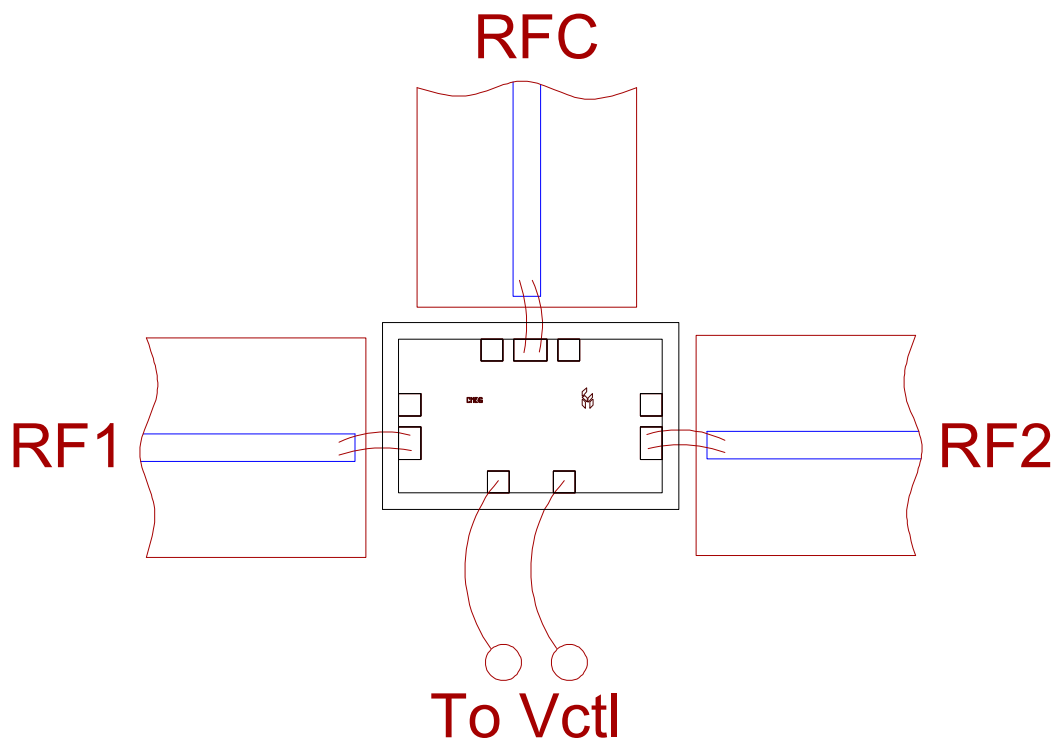

ver 1.0 0916