Novel Low Cost Green-Power PWM Controller With Soft Start & Frequency Jitter

Feature

- Low Cost, PWM&PFM&CRM (Cycle Reset Mode)
- Low Start-up Current (about 1.5μA)
- Low Operating Current (about 2.2mA)
- Current Mode Operation
- Under Voltage Lockout (UVLO)
- Built-in Synchronized Slope Compensation
- Built-in fixed soft start with 1.2mS
- Built-in Frequency jitter for better EMI Signature
- Programmable PWM Frequency
- Audio Noise Free Operation
- Leading edge Blanking on Sense input
- Constant output power limiting for universal AC input Range
- SOT-23-6L 、 SOP8 and DIP-8 Pb-Free Packaging
- Compatible with [SG6848 \(6849\)](#) / [SG5701/SG5848/LD7535 \(7550\)](#) / [OB2262 \(2263\)/OB2278 \(2279 \)](#)
- **Complete Protection with**
 - Soft Clamped GATE output voltage 16.5V
 - VDD over voltage protect 25.6V
 - Cycle-by-cycle current limiting
 - Sense Fault Protection
 - OTP (Over Temperature Protection)
 - Output SCP (Short circuit Protection)
 - Output OLP (Over Load Protection)
 - Latch mode After OLP&SCP
 - High-Voltage CMOS Process with ESD

Applications

- Switching AC/DC Adaptor
- Battery Charger
- Open Frame Switching Power Supply
- Standby Power Supplies
- Set-Top Box Power Supplies
- 384X Replacement

General Description

The CMD2264 is a highly integrated low cost current mode PWM controller, which is ideal for small power current mode of offline AC-DC fly-back converter applications. Making use of external resistors, the IC changes the operating frequency and automatically enters the PFM/CRM (Cycle Reset Mode) under light-load/zero-load conditions. This can minimize standby power consumption and achieve power-saving functions. With a very low start-up current, the CMD2264 could use a

large value start-up resistor (2Mohms). Built-in synchronized slope compensation enhances the stability of the system and avoids sub-harmonic oscillation. Dynamic peak current limiting circuit minimizes output power change caused by delay time of the system over a universal AC input range. Leading edge blanking circuit on current sense input could remove the signal glitch due to snubber circuit diode reverse recovery and thus greatly reduces the external component count and system cost

CMD2264 Product Specification

in the design. Cycle-by-Cycle current limiting ensures safe operation even during short-circuit.

Excellent EMI performance is achieved built-in soft start with 1.2mS, soft driver and frequency jitter.

The CMD2264 offers perfect protection like OVP(Over Voltage Protection), OLP(Over

Load Protection) , SCP(Short circuit protection), OTP, Sense Fault Protection and OCP(Over current protection). The CMD2264's output driver is soft clamped to maximum 16.5V to protect the power MOSFET. CMD2264 is offered in SOT-23-6L, SOT-8 and DIP-8 packages.

CMD22XX Green-Power Series

Part Number	PWM Frequency	Package	Description
CMD2262	External Adjustable	DIP-8, SOP8 SOT-23-6L	PWM&PF&CRM , Current Mode , Slope Compensation Leading-edge Blanking, GATE Clamped, Over-voltage Protection, Over-current Protection, Soft Drive.
CMD2263	External Adjustable	DIP-8, SOP8 SOT-23-6L	With All Functions of CMD2263 , GATE,soft Clamped.
CMD2264	External Adjustable	DIP-8, SOP8 SOT-23-6L	With All Functions of CMD2263, Frequency jitter, Soft start, Sense Fault Protect, OLP, SCP, OTP
CMD2264	External Adjustable	DIP-8, SOP8 SOT-23-6L	CMD2264 & Latch Mode

CMD2264 Product Specification

Pin Assignment

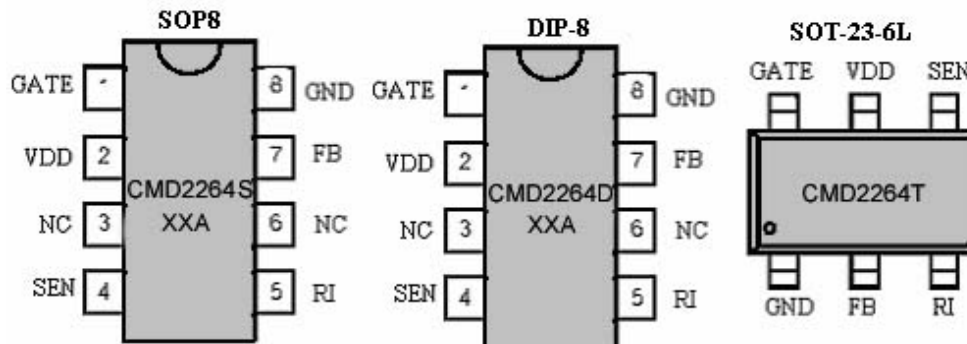

Pin Descriptions

Name	Description
GND	GND Pin
FB	Voltage feedback pin. Output current of this pin could controls the PWM duty cycle, OLP and SCP.
RI	This pin is to program the switching frequency. By connecting a resistor to ground to set the switching frequency.
SEN	Current sense pin, a resistor connects to sense the MOSFET current.
VDD	Supply voltage pin.
GATE	Totem output to drive the external power MOSFET.

TYPICAL APPLICATION

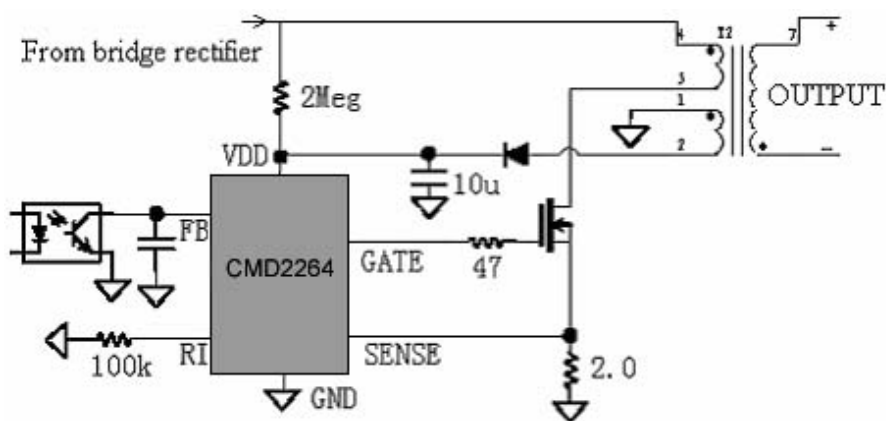

Block Diagram

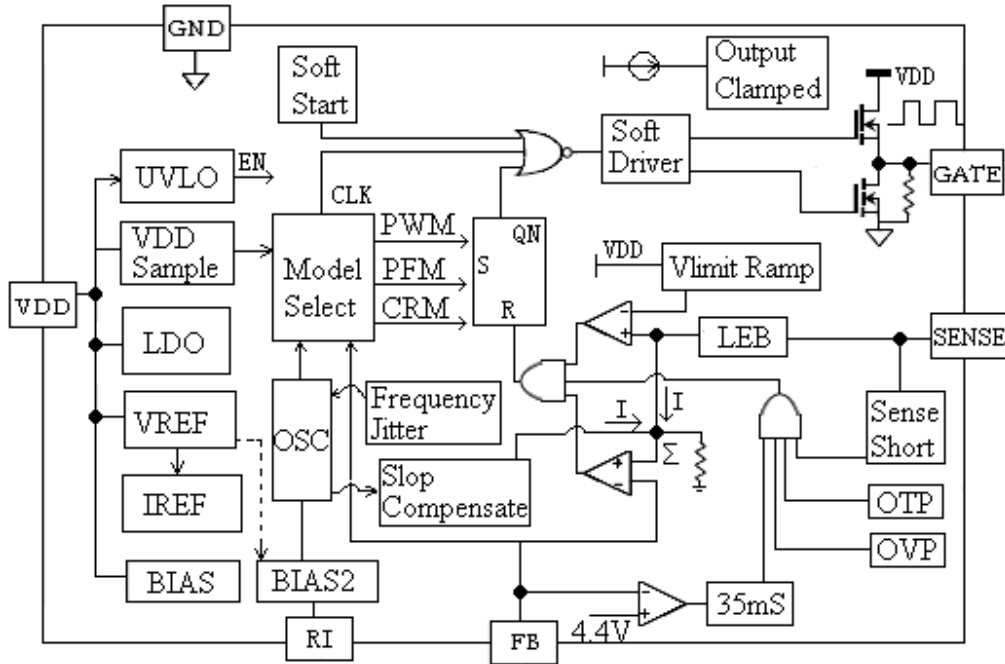

Simplified Internal Circuit Architecture

Absolute Maximum Ratings

Symbol	Parameter	Rating	Unit
V _{DD}	Supply voltage Pin Voltage	40	V
I _{OVP}	VDD OVP maximal enter current	20	mA
V _{FB}	Input Voltage to FB Pin	-0.3 to 6V	V
V _{SEN}	Input Voltage to SEN Pin	-0.3 to 6V	V
P _D	Power Dissipation	300	mW
	ESD Capability, HBM Model	2500	V
	ESD Capability, Machine Model	250	V
T _L	Lead Temperature (Soldering)	SOT-23-6L (20S)	220
		DIP-8 (10S)	260
		SOP-8 (10S)	230
T _{STG}	Storage Temperature Range	-55 to + 150	

RECOMMENDED OPERATION CONDITION

Symbol	Parameter	Min ~ Max	Unit
V _{DD}	VDD Supply Voltage	11~20	V
RI	RI PIN Resistor Value	40~200	K ohm
T _{OA}	Operation Ambient Temperature	-20~85	
P _{OMAX}	Maximal Output Power	0~80	W
F _{PWM}	Frequency of PWM	30~150	kHz

CMD2264 Product Specification

Electrical Characteristics (Ta=25°C unless otherwise noted, V_{DD} = 15V)

Symbol	Parameter	Conditions	Min.	Typ.	Max.	Unit
Supply Voltage (V_{DD} Pin)						
I _{ST}	Startup Current			1.5		μA
I _{SS}	Operating Current	V _{FB} =0V		3.2		mA
		V _{FB} =3V		2.2		mA
		V _{FB} =Open		1.65		mA
V _{DDON}	Turn-on Threshold Voltage			12.8		V
V _{DDOFF}	Turn-off Threshold Voltage			7.8		V
V _{DDCLAMP}	VDD Clamp Voltage	I _{VDD} =20mA		25.6		V
V _{DDAIS}	Anti Intermission Surge VDD Voltage			12.7		V
T _{SS}	Soft start Time			1.2		mS
T _{OFF}	Over temperature Protection			130		
T _{RESTART}	Temperature restart			100		
Voltage Feedback (FB Pin)						
I _{FB}	Short Circuit Current	V _{FB} =0V		1.57		mA
V _{FB}	Open Loop Voltage	V _{FB} =Open		4.6		V
I _{FB_OD}	Zero Duty Cycle FB current			1.47		mA
I _{PFM}	Enter PFM FB current			1.37		mA
I _{CRM}	Enter CRM FB current			1.45		mA
V _{PFM}	Enter PFM Threshold V _{FB}			0.51		V
V _{CRM}	Enter CRM Threshold V _{FB}			0.30		V
I _{OLP&SCP}	Enter OLP&SCP FB current			152		uA
V _{OLP&SCP}	Enter OLP&SCP FB voltage			4.2		V
T _{OLP&SCP}	OLP&SCP min. delay Time	RI=100K	33		50	mS
Current Sensing (SEN Pin)						
V _{TH_L}	SEN Minimum Voltage Lever			0.65		V
V _{TH_H}	SEN Maximum Voltage Lever			0.85		V
T _{PD}	Delay to Output			150		ns
R _{CS}	Input Impedance			50		KΩ
V _{SCP}	Sense short protect voltage			177		mV
T _{SCP}	Sen. short protect Delay Time			1.2		mS

CMD2264 Product Specification

Oscillator (RI Pin)						
F _{OSC}	Normal Frequency	RI=100Kohm	55	60	65	KHz
F _{PFM}	PFM Frequency	RI=100Kohm		22		KHZ
DC _{MAX_W}	Maximum Duty Cycle PWM	RI=100Kohm		77		%
DC _{MAX_F}	Maximum Duty Cycle PFM	RI=100Kohm		14		%
F _{TEMP}	Frequency Temp. Stability	-30-100		5		%
T _{BLANK}	Leading-Edge Blanking Time			300		nS
F _{JITTER}	Frequency jitter	RI=100Kohm	-4		4	%
GATE Drive Output (GATE Pin)						
V _{OL}	Output Low Level	V _{DD} =15V, I _O =20mA			0.8	V
V _{OH}	Output High Level	V _{DD} =15V, I _O =20mA	9			V
T _{R1}	Rising Time	C _L =500pF		123		ns
T _{F1}	Falling Time	C _L =500pF		71		ns
T _{R2}	Rising Time	C _L =1000pF		248		ns
T _{F2}	Falling Time	C _L =1000pF		116		ns
T _{R3}	Rising Time	C _L =1500pF		343		ns
T _{F3}	Falling Time	C _L =1500pF		153		ns
T _{R4}	Rising Time	C _L =2000pF		508		ns
T _{F4}	Falling Time	C _L =2000pF		209		ns
V _{GCLAMP}	Output Clamp Voltage	V _{DD} =20V		16.5		V

Notice: The drive current of GATE pin is a variable value, which is decided by

$I = K(V_{VDD} - V_{GATE} - 2.8)^2$ (Among these, K is a invariable coefficient, V_{GATE} is the voltage of GATE pin, V_{VDD} is the voltage of VDD pin); So the higher the VDD voltage is and the lower the output voltage is, the bigger the drive transient current is. When the GATE voltage is 0V and the VDD voltage is 13V, the output drive current would over 120mA. The output driver current would decrease with increasing of the GATE voltage.

OPERATION DESCRIPTION

Current Mode

Compared to voltage mode control, current mode control has a current feedback loop. When the voltage of the Sense resistor peak current of the primary winding reaches the internal setting value V_{TH} , the register resets and the power MOSFET cuts off. So, to detect and modulate the peak current cycle-by-cycle could control the output of the power supply. The current feedback has a good linear modulation rate and a fast input and output dynamic impact, and avoid the pole that the output filter inductance brings and the two-class system descends to the one-class. So it widens the frequency range and optimizes overload protection and short circuit protection.

Startup Current and Under Voltage Lockout

The startup current of CMD2264 is set to be very low so that a large value startup resistor can be used to minimize the power loss. For AC to DC adaptor with universal input range design, a 2 M Ω , 1/8 W startup resistor and a 10uF/25V VDD hold capacitor could be used.

The turn-on and turn-off threshold of the CMD2264 is designed to 12.8V/7.8V. During startup, the hold-up capacitor must be charge to 12.8V through the startup resistor. The hysteresis is implemented to prevent the shutdown from the voltage dip during startup.

Internal Bias and OSC Operation

A resistor connected between RI pin and GND pin sets the internal constant current source to charge or discharge the internal fixed capacitor. The charge time and discharge time determines the internal clock speed and the switching frequency. Increasing the resistance will reduce the value of the input current and reduce the switching frequency. The relationship between RI and PWM switching frequency follows the below equation within the RI allowed range.

$$F_{osc} = \frac{6000}{RI(K\Omega)} (kHz)$$

For example, a 100k Ω resistor RI could

generate a 13uA constant current and a 60kHz PWM switching frequency. The suggested operating frequency range of CMD2264 is within 30KHz to 150KHz.

Green Power Operation

The power dissipation of switching mode power supply is very important in zero load or light load condition. The major dissipation results from conduction loss, switching loss and consume of the control circuit. However, all of them relates to the switching frequency. There are many difference topologies has been implemented in different chip. The basic operation theory of all these approaches intends to reduce the switching frequency under light-load or no-load condition.

The CMD2264's green power function adapts PWM, PFM and CRM combining modulation. When RI resistor is 100k , the PWM frequency is 60kHz in medium or heavy load operation. Through modifying the pulse width, The CMD2264 could control output voltage. The current of FB pin increases when the load is in light condition and the internal mode controller enters PFM&PWM when the feedback current is over 1.37mA. The operation frequency of oscillator is to descend gradually. When the feedback current is over 1.43mA, the frequency of oscillator is invariable, namely 22kHz.

To decrease the standby consumption of the power supply,

the feedback current is over 1.45mA, mode controller of the CMD2264 would reset internal register all the time and cut off the GATE pin. While the output voltage is lower than the set value, the register would be set, the GATE pin operate again. So the frequency of the internal OSC is invariable, the register would reset some pulses so that the practical frequency is decreased at the GATE pin.

CMD2264 Product Specification

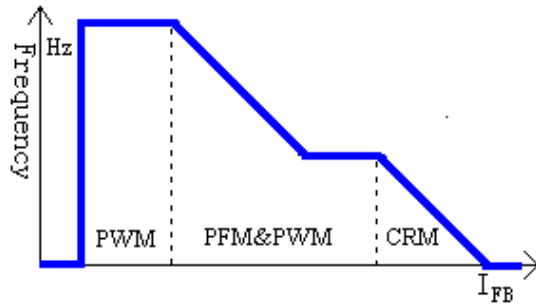

CMD2264 Green-Power Function

Internal Synchronized Slope Compensation

Although there are more advantages of the current mode control than conventional voltage mode control, there are still several drawbacks of peak-sensing current-mode converter, especially the open loop instability when it operates in higher than 50% of the duty-cycle. To solve this problem, the CMD2264 is introduced an internal slope compensation adding voltage ramp to the current sense input voltage for PWM generation. It improves the close loop stability greatly at CCM, prevents the sub-harmonic oscillation and thus reduces the output ripple voltage.

$$V_{SLOP} = 0.33 \times \frac{DUTY}{DUTY_{MAX}} = 0.4389 \times DUTY$$

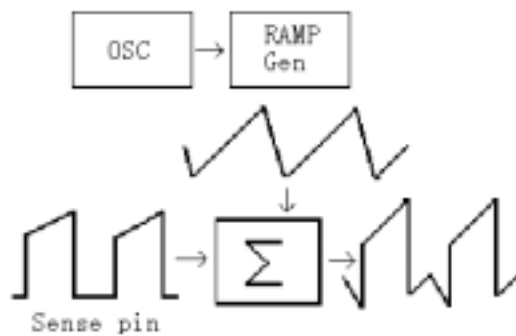

Slope Compensation

Current Sensing & Dynamic peak limiting

The current flowing by the power MOSFET comes into being a voltage V_{SENSE} on the Sense pin cycle-by-cycle, which compares to the internal reference voltage, and controls the reverse of the internal register, limits the peak current I_{MAX} of the

primary of the transformer. The transformer

energy is $E = \frac{1}{2} \times L \times I_{MAX}^2$. So adjusting

the R_{SENSE} can set the maximal output power of the power supply. The current flowing by the power MOSFET has an extra

value ($\Delta I = \frac{V_{IN}}{L_P} \times T_D$) due to the system

delay time that is from detecting the current through the Sense pin to power MOSFET off in the CMD2264 (Among these, V_{IN} is the primary winding voltage of the transformer and L_P is the primary wind inductance). V_{IN} ranges from 85VAC to 264VAC. To guarantee the output power is a constant for universal input AC voltage, there is a dynamic peak limit circuit to compensate the system delay T that the system delay brings on.

$$I_{PEAK_MAX} = \frac{0.65V}{R_{SENSE}} (V_{IN} = 264V)$$

$$I_{PEAK_MAX} = \frac{0.85V}{R_{SENSE}} (V_{IN} = 85V)$$

Soft Start

The CMD2264 features an internal soft start during the initial power on. As soon as VDD reaches ON, the voltage on the internal fixed capacitor is gradually increased from zero up to the maximum internal clamping level. The time of the soft start is fixed about 1.2mS for the constant charge current and the fixed capacitor.

Frequency Jitter

The frequency jittering is introduced in the CMD2264. As following figure, the internal oscillation frequency is modulated by itself. A whole surge cycle includes 8 pulses and the jittering ranges from -4% to +4%. Thus, the function could minimize the electromagnetic interferer from the power supply module.

CMD2264 Product Specification

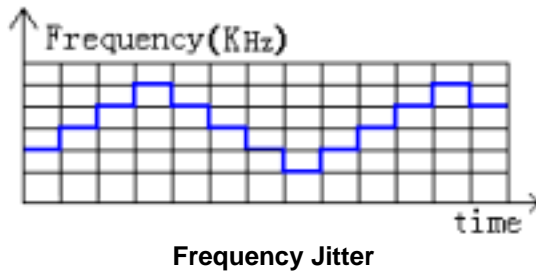

OLP&SCP

To protect the circuit from being damaged under the over load or short circuit condition, a smart OLP&SCP function is implemented in the CMD2264. When short circuit or over load occurs in the output end, the feedback cycle would enhance the voltage of FB pin, while the voltage is over 4.2V or the current from FB is below 152uA, the internal detective circuit would send a signal to shut down the GATE and pull down the VDD voltage, then the circuit is restart. To avoid the wrong operation when circuit starts, the delay time is set. When the RI resistance is 100Kohm, the delay time $T_{OLP\&SCP}$ is between 33mS and 50mS. The relationship between RI and $T_{OLP\&SCP}$ follows the below equation.

$$\frac{RI \times 2}{6 \times 10^3} (mS) < T_{OLP\&SCP} < \frac{RI \times 3}{6 \times 10^3} (mS)$$

Over Temperature Protection

The CMD2264 has a built-in temperature sensing circuit to shut down PWM output once the junction temperature exceeds 130°C. While PWM output is shut down, VDD voltage will gradually drop to the UVLO voltage, and VDD voltage will gradually increase again. If the junction temperature is still higher than 130°C, the PWM controller will be shut down again. This situation will continue until the temperature drops below 100°C. The PWM output will then be turned back. The temperature hysteresis window for the OTP circuit is 30°C.

Sense Fault Detect

Changing the resistance of Sense pin could limit the maximal peak current of power MOSFET. If the Sense pin is short circuit to the ground and the CMD2264 is overload, the power MOSFET and transformer is easy to be shattered. So, the

short circuit protection is built in the CMD2264. Every time to start up, the circuit would detect the voltage of the Sense pin when the start signal is send. If the voltage keeps lower than 177mV, the circuit would be cut off and restart in 1.2mS. But, when the switch power is cut off, there could always be a big noise on the ground, so to achieve this function, it is strongly suggested that the board on the ground of the sense pin must be attention.

Anti Intermission Surge

When the power supplies change the heavy load to light load immediately, there could be tow phenomena caused by system delay. They are output voltage overshoot and intermission surge. To avoid it, the anti intermission surge is built in the CMD2264. If it occurs, the FB current is to increase rapidly, the GATE would be cut off for a while, VDD pin voltage descends gradually. When VDD reaches 12.7V, the GATE pin would operate again, which the frequency is 22KHz and the max. Duty cycle is 14%.

Leading-edge Blanking (LEB)

Each time the power MOSFET is switched on, a turn-on spike will inevitably occur at the Sense pin, which would disturb the internal signal from the sampling of the R_{SENSE} . There is a 300nS leading edge blanking time built in to avoid the effect of the turn-on spike, and the power MOSFET cannot be switched off during the moment. So that the conventional external RC filtering on sense input is no longer required.

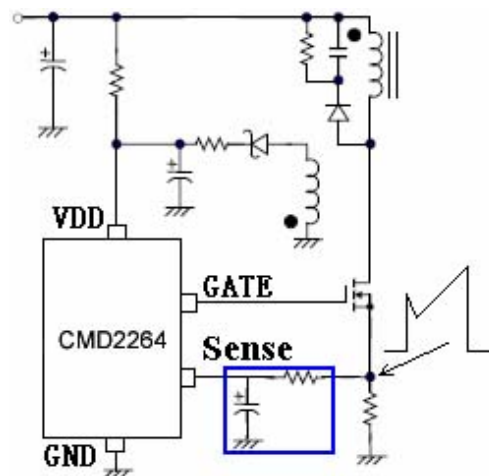

CMD2264 Product Specification

Over Voltage Protection (OVP)

There is a 25.6V over-voltage protection circuit in the CMD2264 to improve the credibility and extend the life of the chip. When the VDD voltage is over 25.6V, the GATE pin is to shutdown immediately and the VDD voltage is to descend rapidly.

GATE Driver & Soft Clamped

The CMD2264' output designs a totem pole to drive a periphery power MOSFET. The dead time is introduced to minimize the transfixion current during the output operating. The novel soft clamp technology is introduced to protect the periphery power MOSFET from breaking down and current saturation of the Zener.

PACKAGE DIMENSIONS

DIP-8L

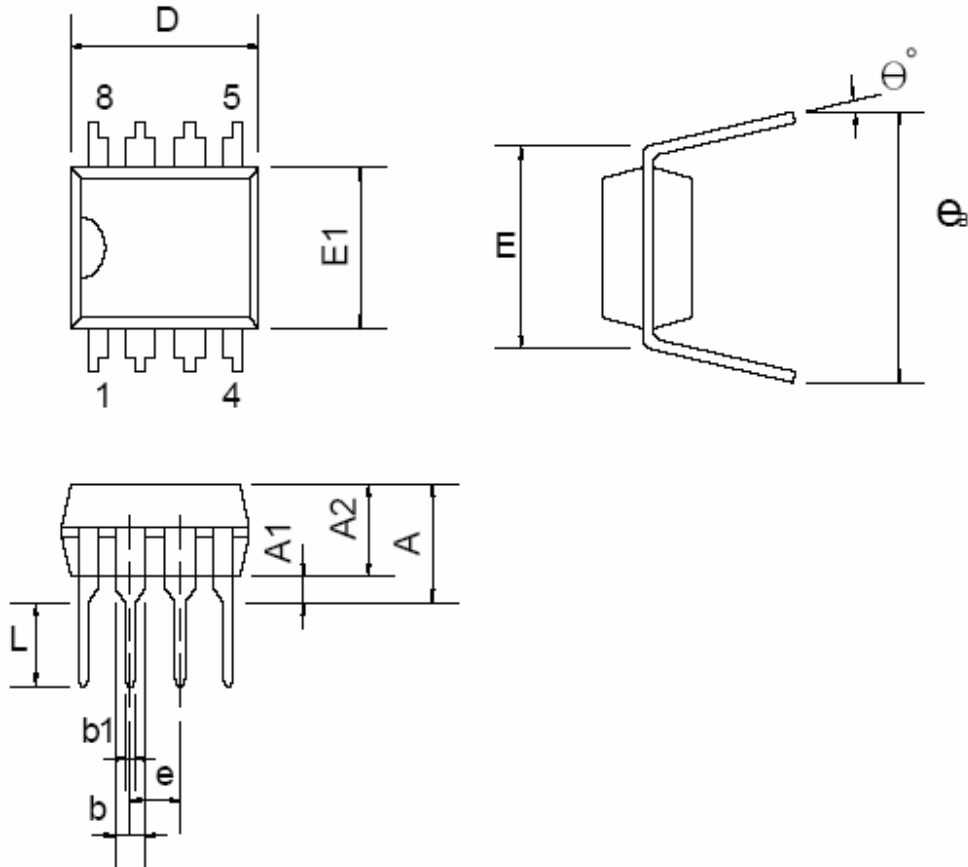

Dimensions

Symbol	Millimeters			Inches		
	Min.	Typ.	Max.	Min.	Typ.	Max.
A			5.334			0.210
A1	0.381			0.015		
A2	3.175	3.302	3.429	0.125	0.130	0.135
b		1.524			0.060	
b1		0.457			0.018	
D	9.017	9.271	10.160	0.355	0.365	0.400
E		7.620			0.300	
E1	6.223	6.350	6.477	0.245	0.250	0.255
e		2.540			0.100	
L	2.921	3.302	3.810	0.115	0.130	0.150
eB	8.509	9.017	9.525	0.335	0.355	0.375
θ°	0°	7°	15°	0°	7°	15°

SOT-23-6L

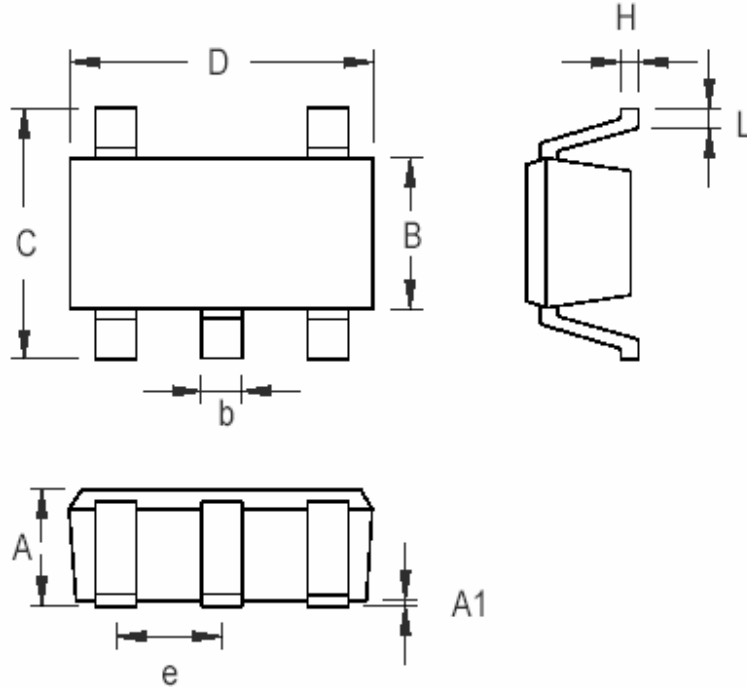

Symbol	Dimensions In Millimeters		Dimensions In Inches	
	Min	Max	Min	Max
A	0.700	1.000	0.028	0.039
A1	0.000	0.100	0.000	0.004
B	1.397	1.803	0.055	0.071
b	0.300	0.559	0.012	0.022
C	2.591	3.000	0.102	0.118
D	2.692	3.099	0.106	0.122
e	0.838	1.041	0.033	0.041
H	0.080	0.254	0.003	0.010
L	0.300	0.610	0.012	0.024

SOP-8L

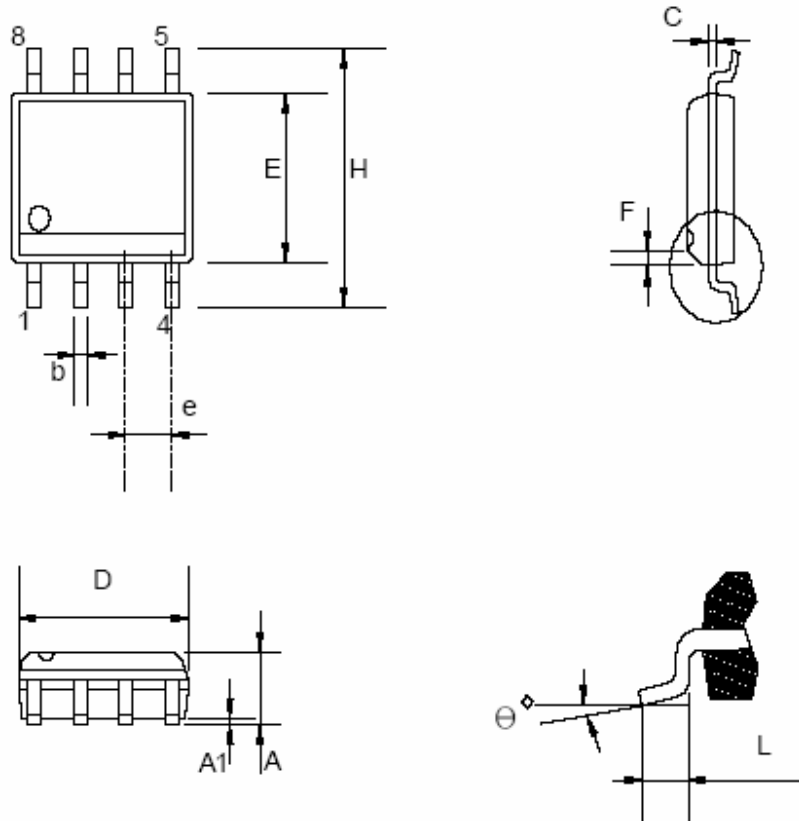

Dimensions DISCLAIMERS

Symbol	Millimeter			Inch		
	Min.	Typ.	Max.	Min.	Typ.	Max.
A	1.346		1.752	0.053		0.069
A1	0.101		0.254	0.004		0.010
b		0.406			0.016	
c		0.203			0.008	
D	4.648		4.978	0.183		0.196
E	3.810		3.987	0.150		0.157
e	1.016	1.270	1.524	0.040	0.050	0.060
F		0.381X45 °			0.015X45 °	
H	5.791		6.197	0.228		0.244
L	0.406		1.270	0.016		0.050
θ	0°		8°	0°		8°