

### Features

- ▶ Ultra wideband performance
- ▶ Low noise figure
- ▶ Low current consumption
- ▶ Excellent return losses
- ▶ Small die size

### Description

The CMD240 is wideband GaAs MMIC distributed low noise amplifier die which operates from DC to 22 GHz. The amplifier delivers greater than 15 dB of gain with a corresponding noise figure of 2.2 dB and output 1 dB compression point of 19 dBm at 10 GHz. The CMD240 is a 50 ohm matched design which eliminates the need for RF port matching. The CMD240 offers full passivation for increased reliability and moisture protection.

### Functional Block Diagram

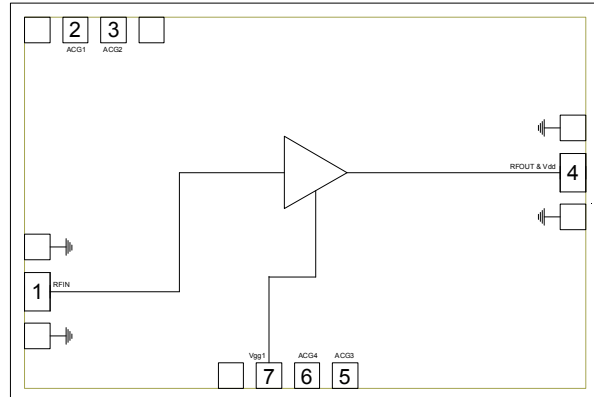

### Electrical Performance - $V_{dd} = 5.0$ V, $I_{dd} = 80$ mA, $T_A = 25$ °C, $F = 10$ GHz

Parameter	Min	Typ	Max	Units
Frequency Range	DC - 22			GHz
Gain		15		dB
Noise Figure		2.2		dB
Input Return Loss		18		dB
Output Return Loss		15		dB
Output P1dB		19		dBm
Output IP3		28		dBm
Supply Current		80		mA

### Specifications

#### Absolute Maximum Ratings

Parameter	Rating
Drain Voltage, V <sub>dd</sub>	10 V
Gate Voltage, V <sub>gg</sub>	-2.5 to 0 V
RF Input Power	+20 dBm
Channel Temperature, T <sub>ch</sub>	150 °C
Power Dissipation, P <sub>diss</sub>	1.7 W
Thermal Resistance $\Theta_{JC}$	38 °C/W
Operating Temperature	-55 to 85 °C
Storage Temperature	-55 to 150 °C

Exceeding any one or combination of the maximum ratings may cause permanent damage to the device.

#### Recommended Operating Conditions

Parameter	Min	Typ	Max	Units
V <sub>dd</sub>	5.0	5.0	8.0	V
I <sub>dd</sub>		80		mA
V <sub>gg</sub>		-0.6		V

Electrical performance is measured at specific test conditions. Electrical specifications are not guaranteed over all recommended operating conditions.

#### Electrical Specifications, V<sub>dd</sub> = 5.0 V, I<sub>dd</sub> = 80 mA, T<sub>A</sub> = 25 °C

Parameter	Min	Typ	Max	Min	Typ	Max	Units
Frequency Range	DC - 22			6 - 18			GHz
Gain	12	15		12	15		dB
Noise Figure		2.5			2.2		dB
Input Return Loss		15			15		dB
Output Return Loss		13			13		dB
Output P1dB	15	18		17	19		dBm
Output IP3		26.5			27.5		dBm
Supply Current	55	80	105	55	80	105	mA
Gain Temperature Coefficient		0.008			0.008		dB/°C
Noise Figure Temperature Coefficient		0.009			0.009		dB/°C

ver 1.7 1018

### Typical Performance

**Broadband Performance,  $V_{dd} = 5\text{ V}$ ,  $V_{gg} = -0.6\text{ V}$ ,  $I_{dd} = 80\text{ mA}$ ,  $T_A = 25\text{ }^\circ\text{C}$**

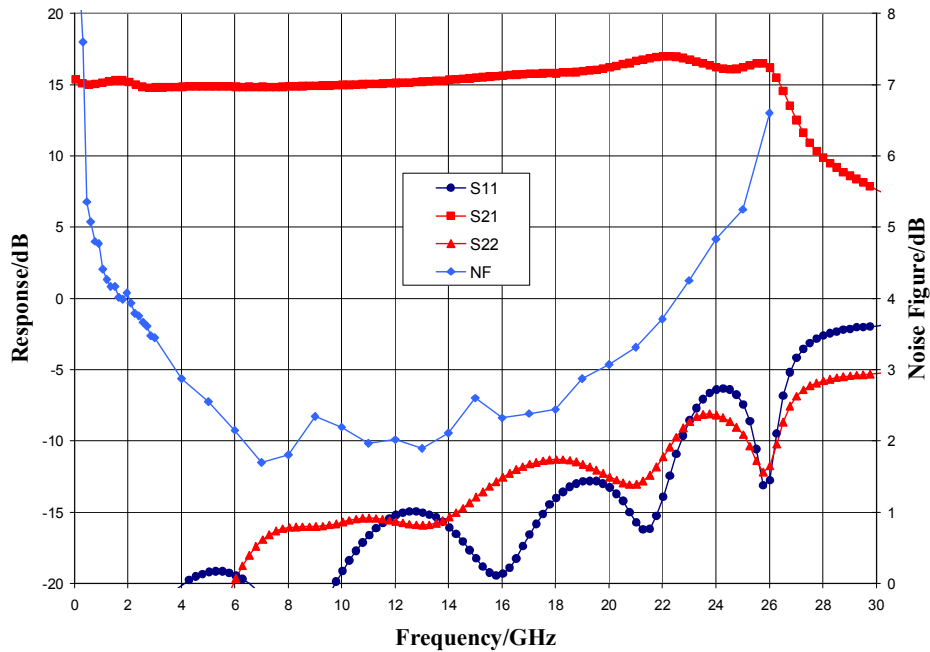

**Narrow-band Performance,  $V_{dd} = 5\text{ V}$ ,  $V_{gg} = -0.6\text{ V}$ ,  $I_{dd} = 80\text{ mA}$ ,  $T_A = 25\text{ }^\circ\text{C}$**

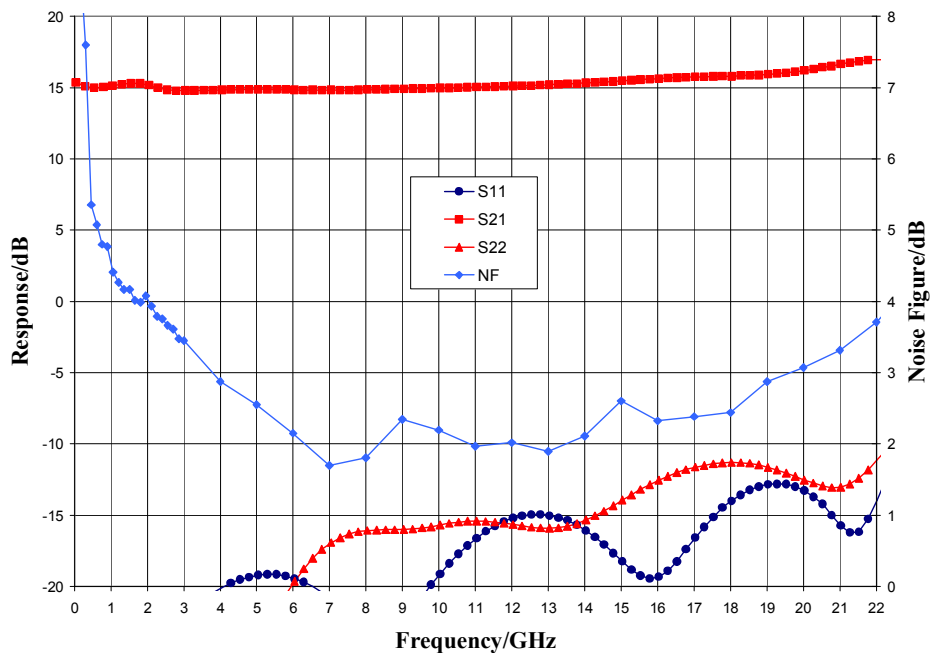

ver 1.7 1018

### Typical Performance

**Gain vs. Temperature,  $V_{dd} = 5\text{ V}$ ,  $V_{gg} = -0.6\text{ V}$**

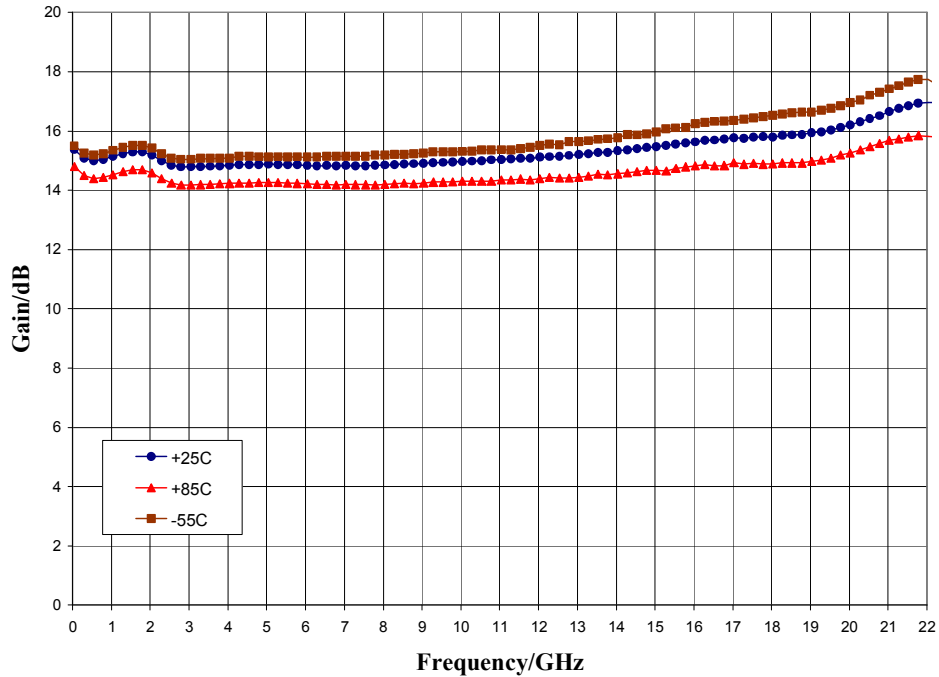

**Noise Figure vs. Temperature,  $V_{dd} = 5\text{ V}$ ,  $V_{gg} = -0.6\text{ V}$**

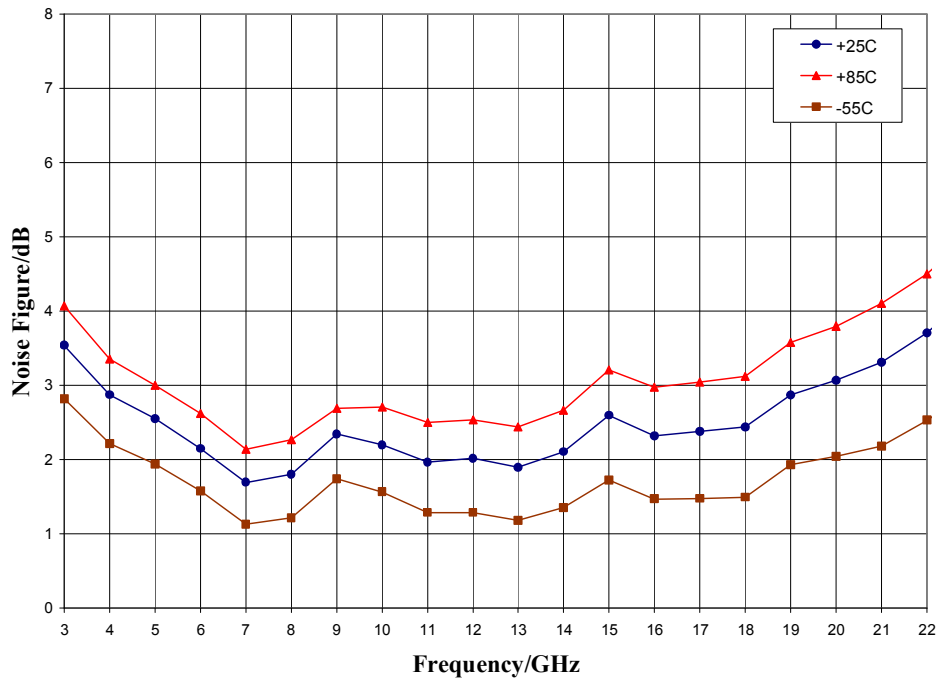

ver 1.7 1018

### Typical Performance

Output Power,  $V_{dd} = 5\text{ V}$ ,  $V_{gg} = -0.6\text{ V}$ ,  $T_A = 25\text{ }^\circ\text{C}$

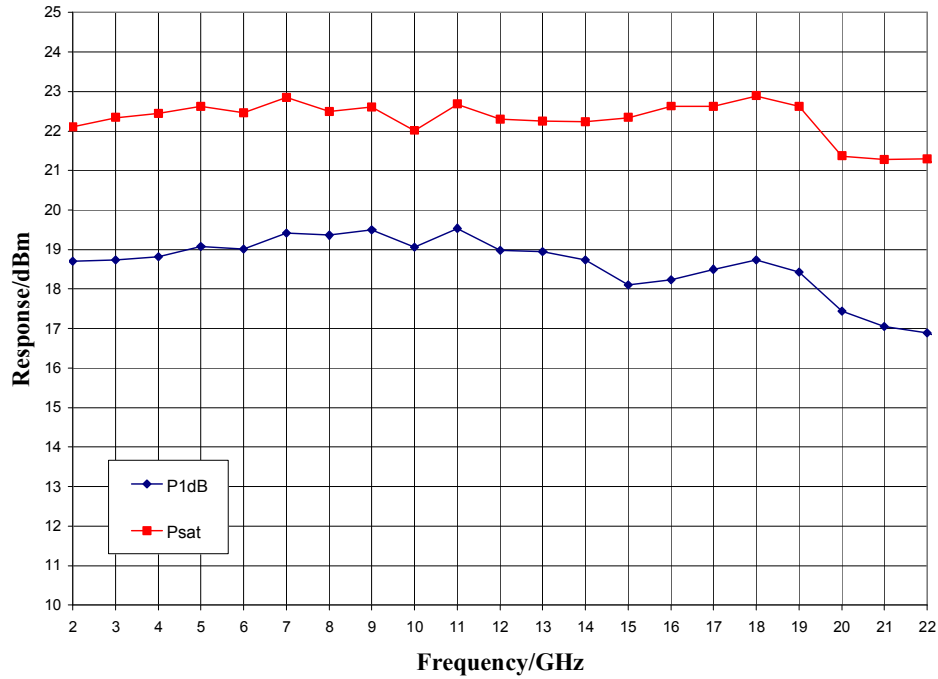

P1dB vs. Temperature,  $V_{dd} = 5\text{ V}$ ,  $V_{gg} = -0.6\text{ V}$

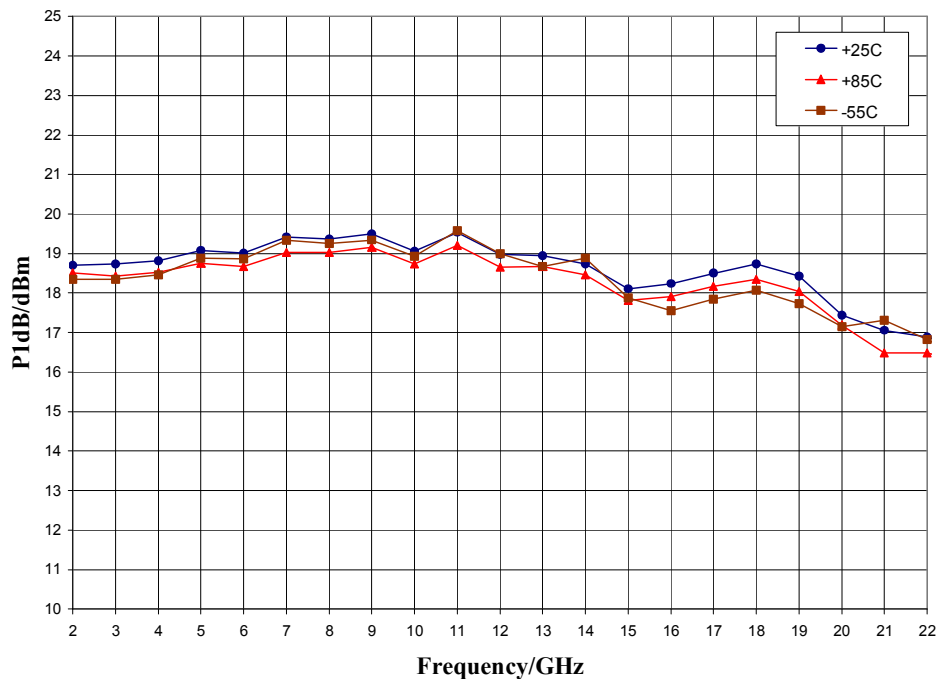

ver 1.7 1018

### Typical Performance

Output IP3 vs. Temperature,  $V_{dd} = 5\text{ V}$ ,  $V_{gg} = -0.6\text{ V}$

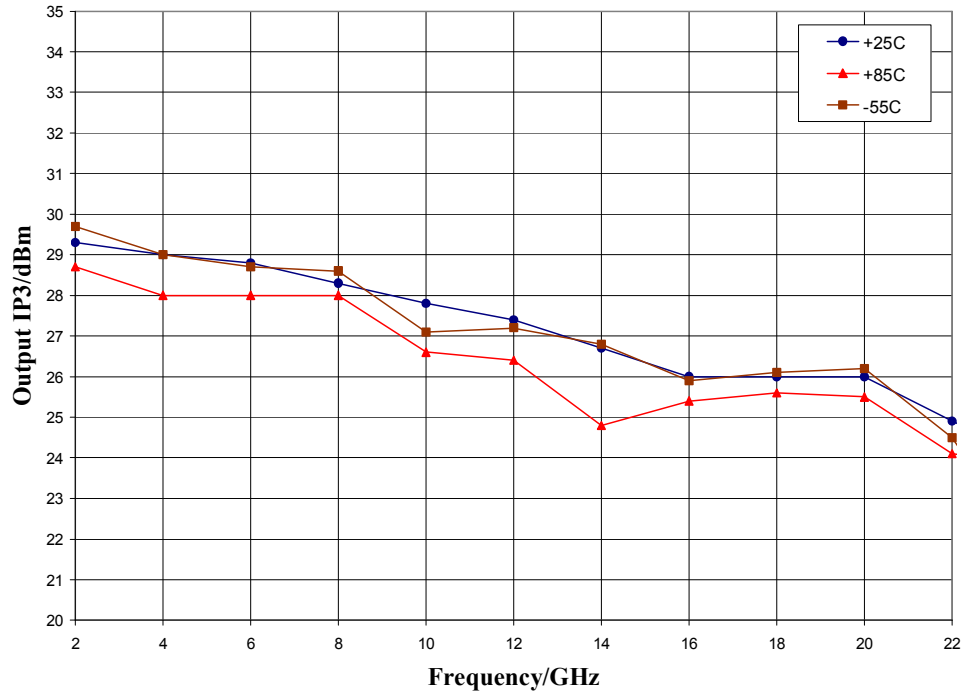

### Mechanical Information

#### Die Outline (all dimensions in microns)

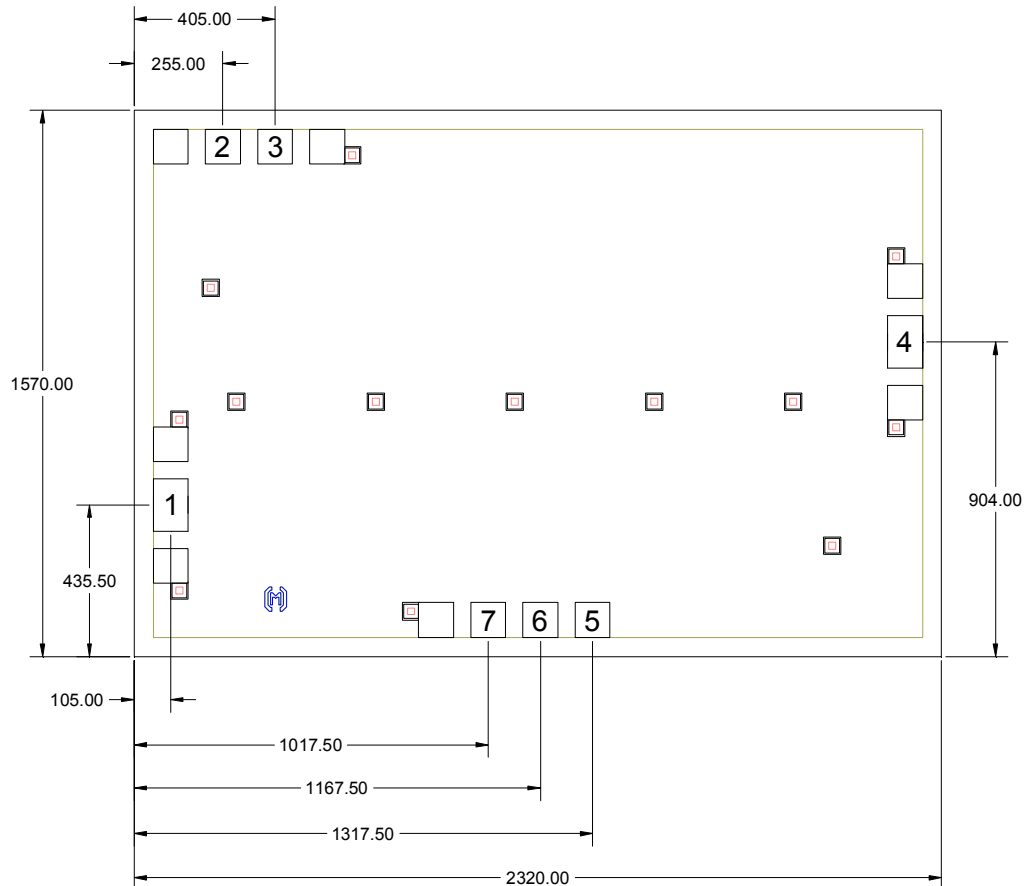

#### Notes:



1. No connection required for unlabeled pads
2. Backside is RF and DC ground
3. Backside and bond pad metal: Gold
4. Die is 70 microns thick
5. DC bond pads (2, 3, 5, 6, 7) are 100 x 100 microns
6. RF bond pads (1, 4) are 100 x 150 microns

### Pad Description

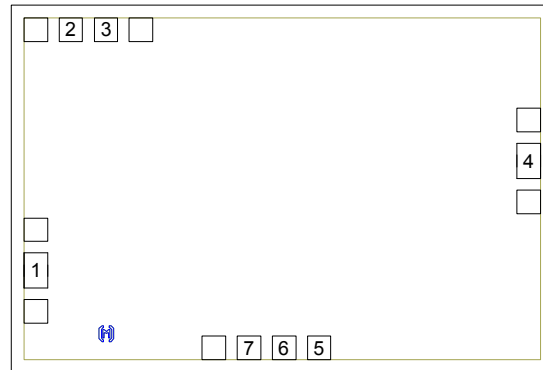
### Pad Diagram

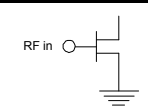
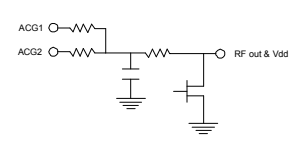
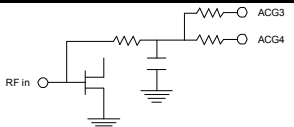
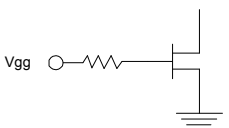

### Functional Description

Pad	Function	Description	Schematic
1	RF in	50 ohm matched input	
2, 3	ACG1, 2	Low frequency termination. Attach bypass capacitor per application circuit	
4	RF out & Vdd	Power supply voltage and 50 ohm matched output	
5, 6	ACG3, 4	Low frequency termination. Attach bypass capacitor per application circuit	
7	Vgg	Power supply voltage Decoupling and bypass caps required	
Backside	Ground	Connect to RF / DC ground	



### Applications Information

#### Assembly Guidelines

The backside of the CMD240 is RF ground. Die attach should be accomplished with electrically and thermally conductive epoxy or eutectic attach. Standard assembly procedures should be followed for high frequency devices. The top surface of the semiconductor should be made planar to the adjacent RF transmission lines, and the RF decoupling capacitors placed in close proximity to the DC connections on chip.

RF connections should be made as short as possible to reduce the inductive effect of the bond wire. Use of a 0.8 mil thermosonic wedge bonding is highly recommended as the loop height will be minimized. The RF input and output require a double bond wire as shown.

The semiconductor is 70  $\mu\text{m}$  thick and should be handled by the sides of the die or with a custom collet. Do not make contact directly with the die surface as this will damage the monolithic circuitry. Handle with care.

#### Assembly Diagram

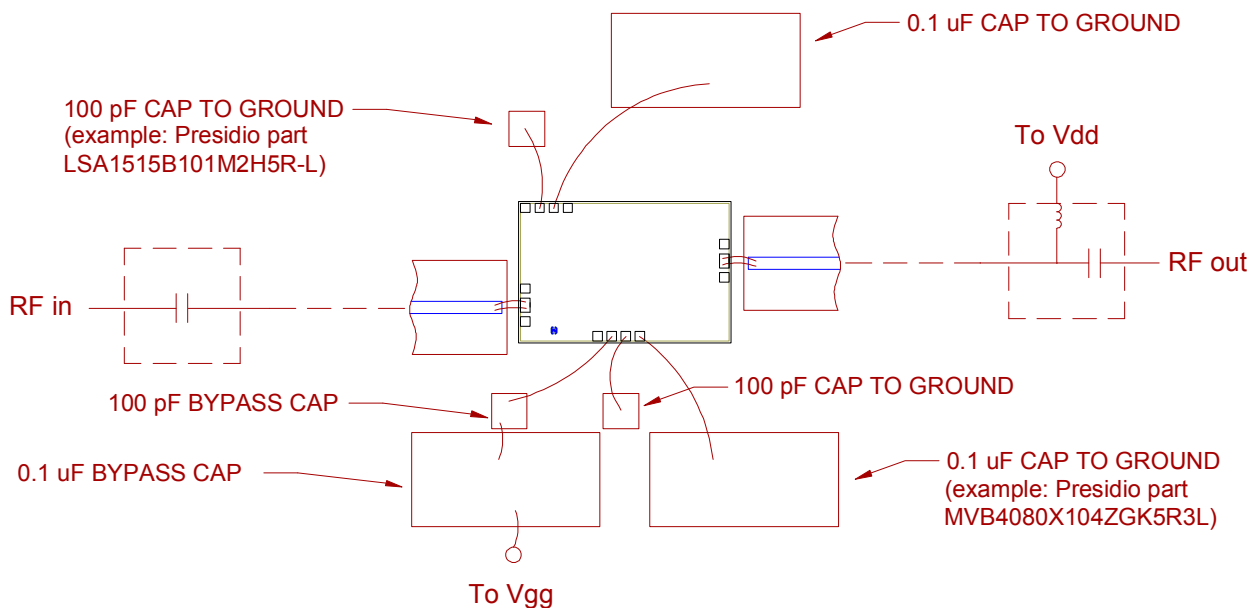

**GaAs MMIC devices are susceptible to damage from Electrostatic Discharge. Proper precautions should be observed during handling, assembly and test.**

ver 1.7 1018

### Applications Information

#### Application Circuit

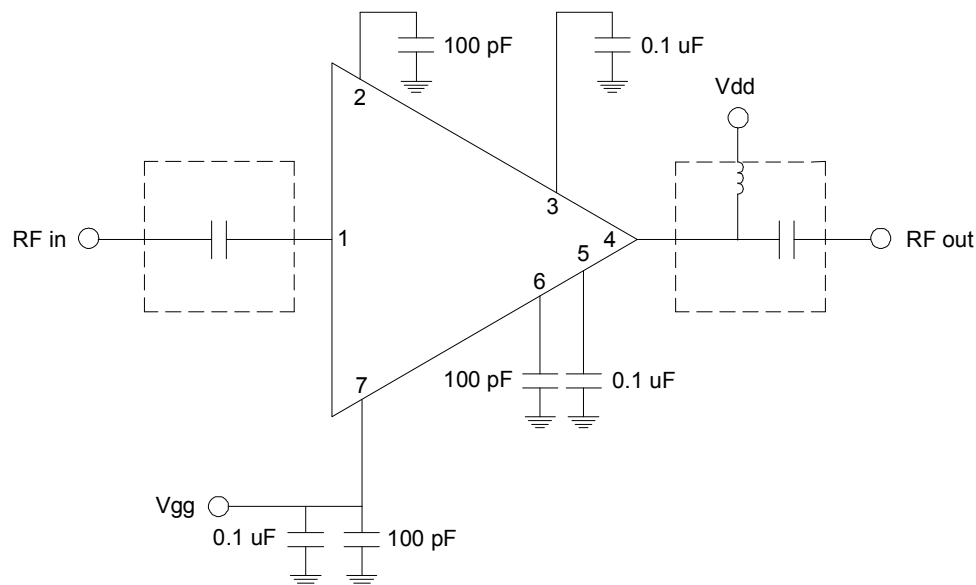

Note: Drain voltage ( $V_{dd}$ ) must be applied through a broadband bias tee or external bias network. External DC block is required on RF input.

#### Biasing and Operation

The CMD240 is biased with a positive drain supply and a negative gate supply. Performance is optimized when the drain voltage is set to +5 V. The nominal gate voltage is -0.6 V.

Turn ON procedure:

1. Apply gate voltage  $V_{gg}$  and set to -2V
2. Apply drain voltage  $V_{dd}$  and set to +5 V
3. Increase  $V_{gg}$  (less negative) to achieve a drain current of 80 mA

Turn OFF procedure:

1. Turn off drain voltage  $V_{dd}$
2. Turn off gate voltage  $V_{gg}$

RF power can be applied at any time.

*Please note, all information contained in this data sheet is subject to change without notice.*

ver 1.7 1018