

CMI8768

PCI 8CH Integrated Sound Chip



DESCRIPTION

CMI8768 is the first high performance (SNR~100dB) 8CH PCI integrated sound chip compatible with PCI V.2.2 specification in the world. With 16bit/96K digital/analog playback capability and versatile driver support, CMI8768 is designed delicately for advanced consumer PC sound card/media center/mainboard/desktop/embedded system/server audio applications. Through integrating a full-duplex 8/2 CODEC and S/PDIF transmitter/receiver, CMI8768 consequently saves much BOM cost for customers. CMI8768, bundled with C-Media friendly and high add-on value driver, provides the most economic and ideal audio solution with the best value-price ratio. Integrated S/PDIF transmitter can deliver 5.1 Dolby® Digital/DTS®, or 6.1/7.1 Dolby® Digital Surround EX/DTS ES DVD soundtracks and up-to-96KHz high-definition audio stream to external receiver satisfying audio enthusiasts and pioneers.

FEATURES

- The global first 8CH single sound chip with embedded codec
- Full-duplex 8CH DAC/2CH ADC
- Supports 96K/16bit playback; 48K/16bit recording
- CE level high-quality Signal-to-Noise Ratio (SNR)-100dB
- Integrated S/PDIF transmitter supports 44.1k/48k/96KHz sample rate (96k not available on Windows Vista)
- PCI Rev. 2.2 compliant with bus mastering modes
- Supports the latest Dolby® Digital EX and DTS® ES 6.1/7.1CH DVD soundtrack playback
- Two S/PDIF inputs for optical and coaxial connectors individually
- Built-in earphone buffer at Front-Out pins (32Ω loading)
- One GPIO (General purpose I/O) support

BLOCK DIAGRAM

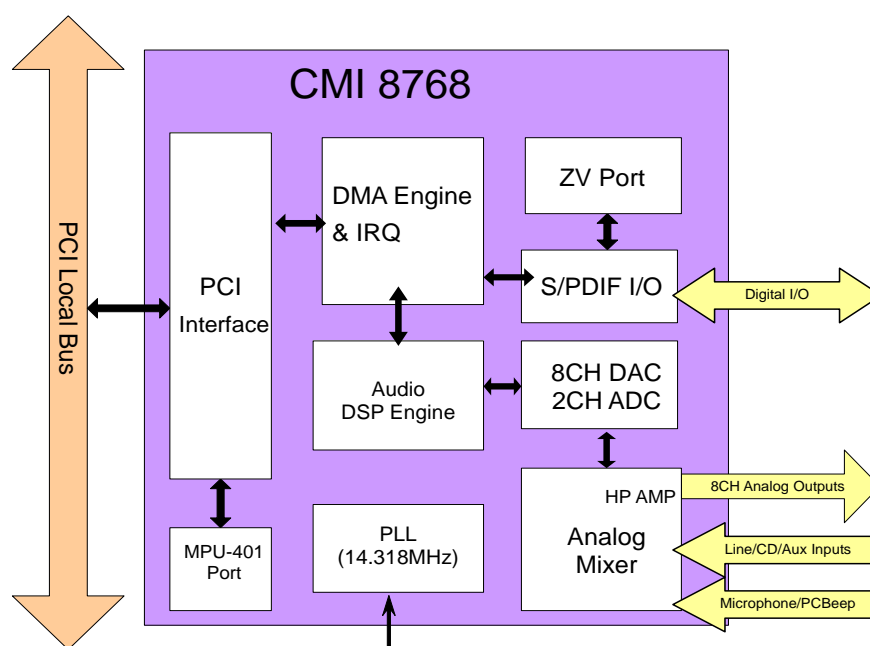

TABLE OF CONTENTS

Revision History.....	3
1. Description and Overview	4
2. Features	5
3. Block Diagram	7
4. Pin Assignment	8
5. Pin Description	9
5.1 Digital I/O	9
5.2 Analog I/O	10
5.3 Power & Ground	10
5.4 NC.....	11
6. Electrical Characteristics	12
6.1 Maximum Ratings.....	12
6.2 Recommended Operation Conditions	12
6.3 Power Consumption.....	12
6.4 Digital Characteristics.....	12
6.5 AC Characteristics	13
7. Mechanical Dimensions.....	16

Revision History

Date	Rev.	Release Note
2003/06/13	Rev. 0.1	Preliminary vision
2003/07/17	Rev. 0.2	Change feature and pin description
2003/10/13	Rev. 0.3	Add analog performance data
2004/03/31	Rev. 0.9	Change product name from 8768+ to 8768 Update feature/overview description (Support 96K/24Bit output) Clarify block diagram (no legacy/SBPRO support) Correct pin function (#125 XS6CH=>GND; #90-97 XGD0-XGD7=>NC) Add Electrical Characteristics data and update analog performance
2004/12/01	Rev. 1.0	Correct pin #59 EXTBASS type from analog output to input Add pin #62 description: XINTREF => Internal reference voltage Change feature description Clarify DirectX9.0 installed is required for 8ch playback support on Windows Indicate pin#9 IDSEL can works only with A16-31 Modify SPDIF-Out high voltage from VDD to 5V
2008/4/18	Rev. 1.1	Change the spec of resolution support Highlight the current spec limitations on Microsoft Windows Vista
2008/10/08	Rev. 1.2	Remove Sensaura support
2010/04/28	Rev. 1.3	Format Modification
2010/05/07	Rev. 1.4	Modify pin 71, 72 as input

1. Description and Overview

CMI8768 is the first high performance (SNR~100dB) 8CH PCI integrated sound chip compatible with PCI V.2.2 specification in the world. With 16bit/96K digital/analog playback capability and versatile driver support, CMI8768 is designed delicately for advanced consumer PC sound card/media center/mainboard/desktop/embedded system/server audio applications. Through integrating a full-duplex 8/2 CODEC and S/PDIF transmitter/receiver, CMI8768 consequently saves much BOM cost for customers. CMI8768, bundled with C-Media friendly and high add-on value driver, provides the most economic and ideal audio solution with the best value-price ratio.

Integrated S/PDIF transmitter can deliver 5.1 Dolby® Digital/DTS®, or 6.1/7.1 Dolby® Digital Surround EX/DTS ES DVD soundtracks and up-to-96KHz high-definition audio stream to external receiver satisfying audio enthusiasts and pioneers. The S/PDIF-Out data can meet the requirement of SCMS (Serial Copy Management System) for digital content serial copy protection legislated by consumer audio industry. CMI8768 also supports MPU-401 MIDI port for external musical instrument input.



Figure 1. Graphic User Interface Samples-- Main Setting & Mixer

Being compatible with various industrial standards for gaming such as EAX™ 1.0&2.0, Direct Sound™ 3D(not available due to Windows Vista’s architecture change), C-Media CMI8768 can provide enthusiastic gamers breathtaking sound experience in gaming.

C-Media proprietary Xear 3DTM sound technology empowers users to shift virtual speakers anywhere they want for optimizing the personal sound field. Virtual speakers can even deliver up-to-7.1 channel surround

sounds over only 2 physical speakers or headphones. C-Media unique Magic Voice™ functionality can reform your microphone voice through the recording process delivering amazing disguise effects for fun in many applications, such as Internet phone, messenger, online games, etc. Microphone echo and key-shifting features are well designed for karaoke application. Other sound effects like 10-band Equalizer and 27 environment effects can enrich user's audio experience and enjoyment.

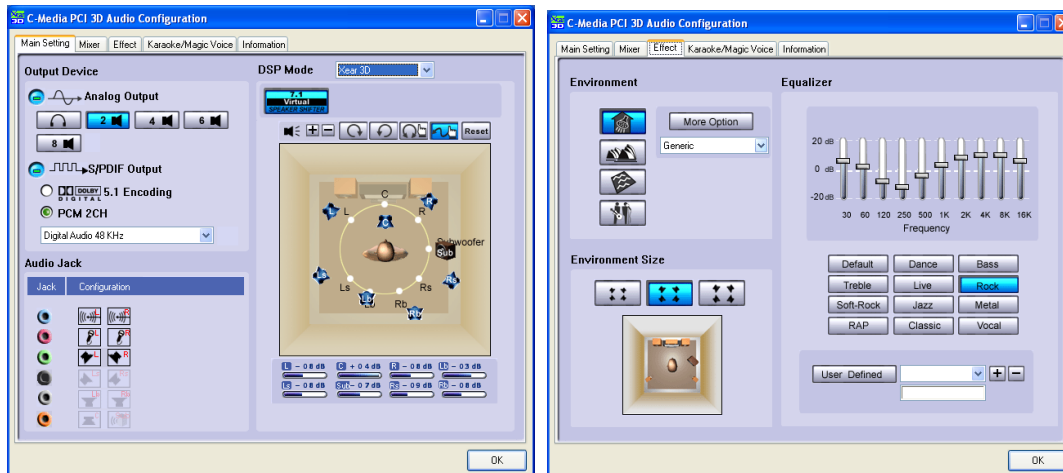

Figure 2. Graphic User Interface Samples—Virtual Speaker SHIFTER & Sound Effect

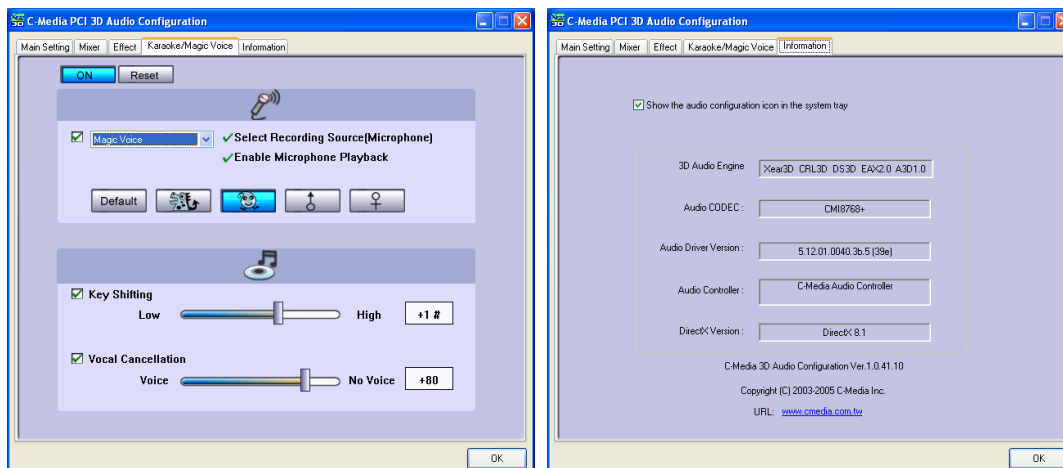

Figure 3. Graphic User Interface Samples—Karaoke & Magic Voice & Information

2. Features

- The global first 8CH single sound chip with embedded codec
- Full-duplex 8CH DAC/2CH ADC
- Supports 96K/16bit playback; 48K/16bit recording
- CE level high-quality Signal-to-Noise Ratio (SNR)- 100dB
- Integrated S/PDIF transmitter supports 44.1k/48k/96KHz sample rate (96k not available on Windows)

CMI8768

PCI 8CH Integrated Sound Chip



Vista)

- PCI Rev. 2.2 compliant with bus mastering modes
- Supports the latest Dolby® Digital EX and DTS® ES 6.1/7.1CH DVD soundtrack playback
- Two S/PDIF inputs for optical and coaxial connectors individually
- Built-in earphone buffer at Front-Out pins (32Ω loading)
- One GPIO (General purpose I/O) support
- External EEPROM Interface for SVID\SSID R/W purpose
- Supports MPU401 MIDI UART port
- DirectSound™ 3 HW acceleration compliant (not available on Vista yet)
- Power On/Off anti-pop circuit reference design
- ACPI compliant power down management
- Zoomed Video Port support
- Industrial standard QFP-128 package
- Almost pin-to-pin compatible with CMI8738 series
- Digital power = 3.3V & 5V, Analog power = 5V

Valuable S/W:

- C-Media Xear 3D™ 7.1 Virtual Speaker SHIFTER technology
- Interesting Magic Voice™ feature to disguise users' voice tone in all IP phones (Skype, MSN, Yahoo, ...), online games, messenger, and Internet DJ/broadcasting applications
- Unique Karaoke functionality: Mic Echo, Key-shifting, Vocal Cancellation
- Supports most industrial standards of PC 3D sound for gaming, including EAX™ 1.0&2.0, and DirectSound™ 3 SW (not available on Vista)
- 10-band Equalizer with 12 preset modes; 27 global environment effects
- Support 7.1 CH digital audio playback for Windows Vista, XP, 2K, ME, 98SE (Microsoft® DirectX V.9.0 above is required)
- WinCE driver and Linux OSS driver available

CMI8768

PCI 8CH Integrated Sound Chip



3. Block Diagram

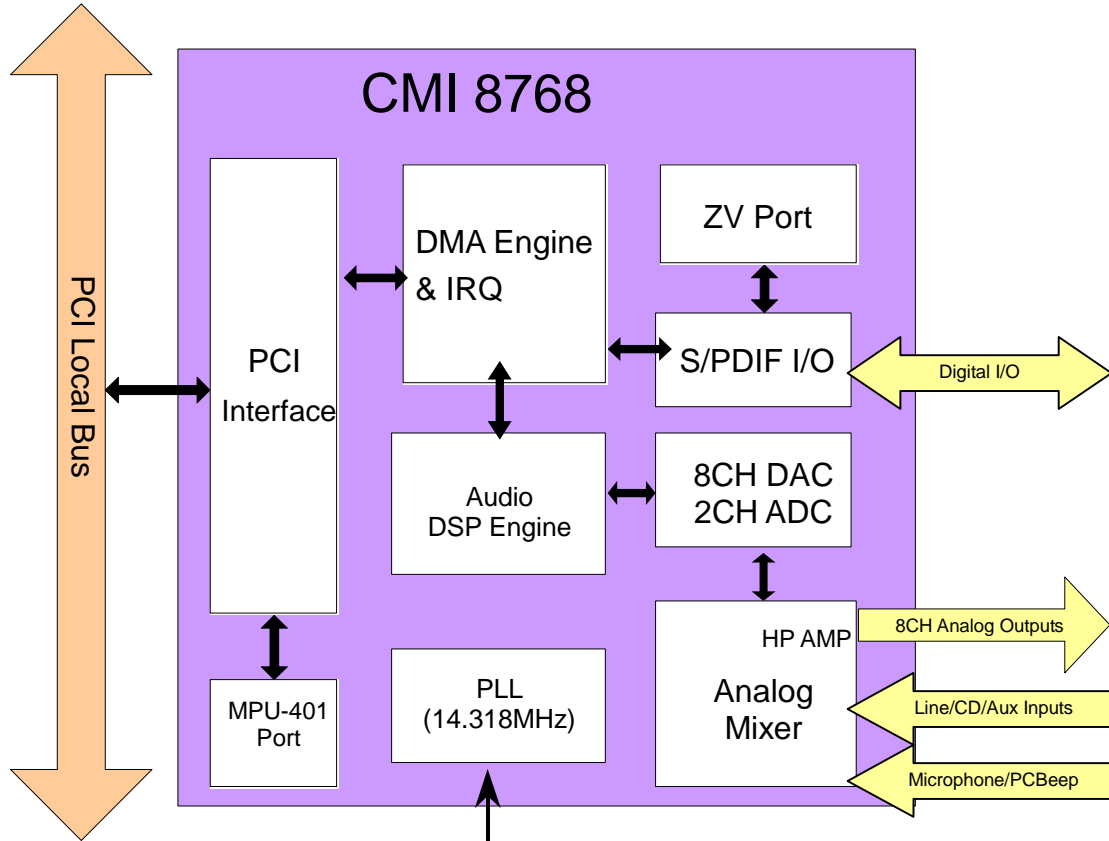

CMI8768

PCI 8CH Integrated Sound Chip



4. Pin Assignment



Top View of CMI8768

5. Pin Description

5.1 Digital I/O

Pin No	Signal Name	Type	Description
1-2, 5-7, 12-16, 19-21, 32-35, 38-41, 43-44, 47-52, 126-128	XA31 - XA0	I/O	PCI bus address and data lines
117	XINTA	O	Interrupt request, active-low
119	XPRST	I	Reset
120	XCLK33	I	PCI bus clock
121	XGNT	I	Bus master grant, active-low.
122	XREQ	O	Bus master request, tri-state output, active-low.
9	XIDSEL	I	ID select, active-high. (only work with A16-31 pin of host controller)
23	XFRAME	I/O	Cycle frame, active-low.
24	XIRDY	I/O	Initiator ready, active-low. The bus master device is ready to transmit or receive data.
25	XTRDY	I/O	Target ready, active-low. The target device is ready to transmit or receive data.
26	XDEVSEL	I/O	Device select, active-low. The target device has decoded the address of the current transaction as its own chip select range.
29	XSTOP	I/O	Stop transaction, active-low. The target device request to the master to stop the current transaction.
30	XPAR	I/O	Parity. The pin indicates even parity across XA31-XA9 and XCBE3-XCBE0 for both address and data phases.
8, 22, 31, 42	XCBE0 - XCBE3	I/O	Multiplexed command / byte enable. These pins indicate cycle type during the address phase of a transaction.
88	XTXD	O	MIDI transmit data
89	XRXD	I	MIDI receive data
55	XIN	I	14.318 MHz crystal input or ext. oscillator input
56	XOUT	O	13.318 MHz crystal output or NC
87	XGBIO0	I/O	General purpose I/O
84	XEECS	O	EEPROM chip select
85	XMBCSZ	I	Audio chip enable select (low:enable)
112	ZVCLK	I	ZV port clock
98	XSPDIFO	O	S/PDIF output (5V)
86	XSPDIFI	I	S/PDIF input 1 / ZV port LR channel clock
113	XSPDIFI2	I	S/PDIF input 2 (TTL 5V) / ZV port data input

5.2 Analog I/O

Pin No	Signal Name	Type	Description
57,58	XSUROUTL-R	O	Back surround out L/R channel
59	EXTBASS	I	External bass input
62	XINTREF	O	Internal reference voltage (for testing purpose)
64,65	XADOUTL-R	O	Front out L/R channel
66,67	XADCFL-R	O	ADC S/H capacitors
68	XCNOUT	O	Center channel output
69	XBSOUT	O	Bass channel output
70	XCDGND	O	CD audio differential ground channel output
71,72	XCDL-R	I	CD audio differential L/R channel input
73,74	XREARL-R	O	Side surround out L/R channel
75,76	XLNL-R	I	Line-In L/R channel
77,78	XAUXL-R	I	Aux input L/R channel
79	XPCSPKIN	I	PC beep or mono input
80	XMIC	I	Microphone input

5.3 Power & Ground

Pin No	Signal Name	Type	Description
4, 10, 18, 27, 37, 45, 100, 124	VDDIO	I	PCI I/O power pin (3.3V)
54, 115	VDDCORE	I	Core logic power pin (3.3V)
83	VDD5V	I	PCI I/O power pin (5V)
3, 11, 17, 28, 36, 46, 53, 82, 99, 116, 125	GND	I	Digital ground
61, 81	AVDD	I	Analog I/O power pin
60, 82	AGND	I	Analog ground

CMI8768

PCI 8CH Integrated Sound Chip



5.4 NC

Pin No	Signal Name
63, 90-97, 101 - 111, 114, 118, 123	NC

6. Electrical Characteristics

6.1 Maximum Ratings

Parameter	Symbol	Min.	Max.	Unit
Digital power voltage	DVDD	3	3.6	V
Analog power voltage	AVDD	3	5.5	V
Digital Input Voltage	VIND	-0.5	3.6	V
Analog Input Voltage	VINA	-0.5	5.5	V
Operating temperature range	TO	0	70	°C
Storage temperature range	TST	-40	125	°C
Maximum power dissipation	PDMAX		300	MW

6.2 Recommended Operation Conditions

Parameter	Symbol	Min.	Typ.	Max.	Unit
Digital Operating Voltage	DVDD	3.135	3.3	3.465	V
Analog Operating voltage	AVDD	4.75	5	5.25	V
Operating Ambient Temperature	TO	0	25	70	°C

6.3 Power Consumption

Parameter	Min.	Typ.	Max.	Unit
Power Supply Current (Normal) AVDD (5.0V)	-	35	-	mA
DVDD (3.3V)	-	10	-	mA

6.4 Digital Characteristics

PARAMETER	Symbol	Condition	Min.	Typ.	Max.	Unit
Input high voltage(PCI I/O)	VIH		2.0	-	VDD+0.3	V
Input low voltage (PCI I/O)	VIL		-0.5	-	0.8	V
Output high voltage	VOH	I _{OH} =1.5mA	2.4	-	VDD	V
Output low voltage	VOL	I _{OL} =-0.5mA	0.0	0.2	0.4	V
Input Leakage Current	IIL	0<Vin<VDD	-70	-	70	μ A
Output Leakage Current	IOL		-70	-	70	μ A
SPDIF IN input high voltage	VIH1		2.6	-	-	V
SPDIF IN input low voltage	VIL1		-	-	2.4	V
SPDIF output high voltage	VOH1		-	VDD5V	-	V
SPDIF output low voltage	VOL1		-	GND	-	V
Input Pin Capacitance	Cin		-	-	10	pF
Pin Inductance	Lpin		-	-	20	nH

6.5 AC Characteristics

Parameter	Symbol	Condition	Min.	Max.	Units
High Clamp Current	I _{ch}	$V_{dd}+4 > V_{in} \geq V_{dd}+1$	$25+(V_{in}-V_{dd}-1)/0.015$	-	mA
Low Clamp Current	I _{cl}	$-3 < V_{in} \leq -1$	$-25+(V_{in}+1)/0.015$	-	mA
Output Rise Slew Rate	SLEW _r	0.2V _{dd} -0.6V _{dd} load	1	4	V/ns
Output Fall Slew Rate	SLEW _f	0.6V _{dd} -0.2V _{dd} load	1	4	V/ns

6.6 Analog Performance

The measurements are performed under the circumstance as:

Tambient = 25°C, AVdd = 5.0V ± 5%, DVdd = 3.3V ± 5%, 10kΩ /50pF external load. Input is 1 kHz sine wave; Sampling frequency = 48 kHz; Bandwidth = 20 to 20 kHz; 0dB attenuation; All sound effects such as 3D effects are disabled.

Parameter	Minimum	Typical	Maximum	Units
Full Scale Input Voltage:				
Line Inputs (Mixer)	-	1.1	1.25	Vrms
Line Inputs (A/D)	-	-	1.25	Vrms
Mic Inputs (20dB boost)	-	0.1	1.25	Vrms
Full Scale Output Voltage:				
Front_Out	-	1.1	-	Vrms
Side_Surround_Out	-	1.1	-	Vrms
Center / LFE_out	-	1.1	-	Vrms
Back_Surround_Out	-	1.1	-	Vrms
SNR (Idle)				
A/A	-	100	-	dB
D/A	-	101	-	dB
A/D	-	86	-	dB
Dynamic Range (-60dB)				
A/A	-	100	-	dB
D/A	-	94	-	dB
A/D	-	85	-	dB
THD+N				
A/A	-	0.005	-	%
D/A	-	0.017	-	%
A/D	-	0.015	-	%
Frequency Response				
A/A	5	-	22,000	Hz
D/A	5	-	22,000	Hz
A/D	10	-	22,000	Hz
Cross-talk @ 10KHz (A/A)	-	100	-	dB
Transition Band	19,200		28,800	Hz
Stop Band	28,800		∞	Hz
Stop Band Rejection	-	-70	-	dB
Out-Of-Band Rejection	-	-65	-	dB

Parameter	Minimum	Typical	Maximum	Units
Power Supply Rejection Ratio	-	-65	-	dB
Master Volume Gain (32 steps)				
Step Size		1.5		dB
Control Range	-54	-	+6	dB
Analog Input Gain (16 steps)				
Step Size		2		dB
Control Range	-30	-	0	dB
Mic Input Gain (16 steps)				
Step Size		3		dB
Control Range	-22	-	+24	dB
Mic Boost Gain	-	+20	-	dB
PCSPK Input Gain (4 steps)				
Step Size		8		dB
Control Range	-24	-	0	dB
Recording Gain (16 steps)				
Step Size		1.5		dB
Control Range	0	-	+22.5	dB
Input Impedance				
Line-In, CD, Aux, PCSPK	-	60	-	K Ω
Mic (w/o Boost)	-	30	-	K Ω
Mic (w/ Boost)	-	10	-	K Ω
Output Impedance				
Amplifier Output	-	2	-	Ω
Non-amp Output	-	200	-	Ω
Output Power				
Line-Out (Front) @32 Ω Load	-	50	-	mW
Line-Out (Front) @10K Ω Load	-	0.16	-	mW
Vrefout	-	2.25	-	V

7. Mechanical Dimensions

QFP-128

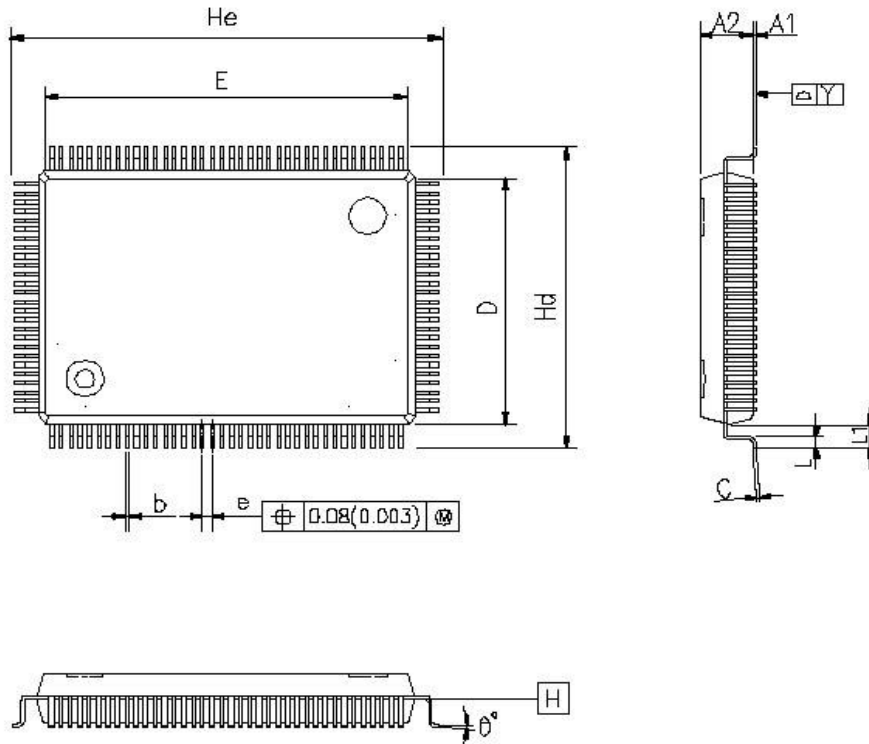

Symbols	Min.	Typ.	Max.	Notes
A1	0.25	0.35	0.45	Jedec outline : N/A
A2	2.57	2.72	2.87	Datum plane \square H is located at the bottom of the mold parting line
b	0.10	0.20	0.30	coincident with where the lead exits the body.
C	0.10	0.15	0.20	Dimensions E and D do not include mold protrusion. Allowable protrusion is 0.25 mm per side. Dimensions E and D do include mold mismatch and are determined at datum plane \square H.
D	13.90	14.00	14.10	
E	19.90	20.00	20.10	Dimension b does not include dambar protrusion.
e	-	0.50	-	
Hd	17.00	17.20	17.40	
He	23.00	23.20	23.40	
L	0.65	0.80	0.95	
L1	-	1.60	-	
Y	-	-	0.08	
θ°	0	-	12	

Unit : mm

CMI8768

PCI 8CH Integrated Sound Chip



— End of Specifications —

C-MEDIA ELECTRONICS INC.

6F., 100, Sec. 4, Civil Boulevard, Taipei, Taiwan 106 R.O.C.

TEL : +886-2-8773-1100

FAX : +886-2-8773-2211

E-MAIL : sales@cmedia.com.tw

Disclaimer:

Information furnished by C-Media Electronics Inc. is believed to be accurate and reliable. However, no responsibility is assumed by C-Media Electronics Inc. for its use, nor for any infringements of patents or other rights of third parties that may result from its use. Specifications subject to change without notice. No license is granted by implication or otherwise under any patent or patent rights of C-Media. Trademark and registered trademark are the property of their respective owners.