

# Oxygen™HD CMI8788

High Performance PCI Audio Processor



## DESCRIPTION

The CMI8788 is compatible with all the popular codecs, from I2S codecs with over 120dB quality to the usual AC97 codecs. This ability gives customers the flexibility to design their products exactly the way they want them. The I2S, AC-Link, 2-wire master bus, and SPI interfaces are used to transfer audio data and control data between the CMI8788 and codecs. To facilitate the connection with existing home audio electronics, the CMI8788 has incorporated the S/PDIF transmitter and receiver with 192k sampling rate. An EEPROM interface is built for the CMI8788 in connection with the EEPROM to store and retrieve the non-evaporable data for customer applications, such as board configuration, sub-vendor and sub-system IDs of the PCI configuration, or any dynamic data that customers want to restore at the next power-on.

## BLOCK DIAGRAM

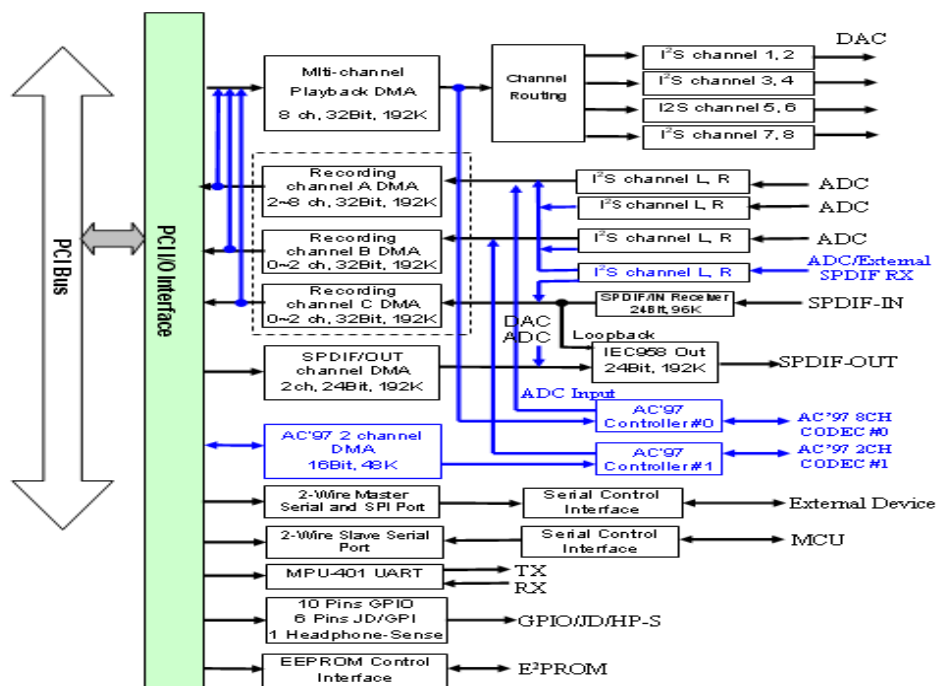

## FEATURES

- PCI 2.2 interface with bus mastering and burst modes
- Only one 24.576MHz oscillator is needed
- 4 synchronous I2S output data stream pairs within 1 flexible output DMA
- Programmable channel routing mechanism among the 4 I2S output pairs
- 4 synchronous I2S input data stream pairs spread in 3 input DMA' s (for Dolby pro-audio applications)
- DTS® Interactive - a real-time 5.1 channel encoder that takes 2 or more channels and encodes them into a DTS bit stream.
- DTS® NeoPC - an up-mix matrix that turns any 2 channel audio into 7.1 channel surround sound
- Dolby® Digital Live (AC-3) real-time 5.1 channel encoding bit-stream to facilitate the connection with CE AV receiver

## TABLE OF CONTENTS

Revision History.....	3
1 Description and Overview .....	4
2 Features .....	4
2.1 Hardware Features.....	4
2.2 Software Features .....	5
3 Applications .....	6
4 Block Diagram .....	7
5 Pin Assignment .....	8
5.1 Pin-out Diagram .....	8
5.2 Pin Descriptions .....	9
6 Electrical Characteristics .....	14
6.1 Maximum Ratings.....	14
6.2 Recommended Operation Conditions .....	14
6.3 Power Consumption.....	14
6.4 DC Characteristics .....	14
6.5 AC Timing Characteristics .....	15
6.5.1 I2S Signal Timing.....	15
6.5.2 Control Interface Timing - 3 - Wire Mode .....	16
6.5.3 Control Interface Timing - 2 - Wire Mode .....	17
6.5.4 EEPROM Interface Timing.....	18
6.5.5 EEPROM AC Timing Characteristics .....	19
6.5.6 AC-Link Timing Characteristics: .....	20
7 Mechanical Specification .....	24
7.1 Package Dimension.....	24

## Revision History

Date	Rev.	Release Note
2005/03/15	0.1	Preliminary vision
2005/04/18	0.2	Modify S/W features
2005/07/22	0.5	Edit for readability
2005/9/12	0.6	Modify S/W features
2006/5/16	1.0	Formal Release
2009/8/24	1.1	Cmedia logo update
2010/4/8	1.2	Modify datasheet layout

## 1 Description and Overview

The CMI8788 is a high quality PCI 32-bit multi-channel audio processor that can be built into home audio electronics or personal computers to provide high fidelity sound playback and processing. It supports up to 12 output channels and 8 input channels. The 12 output channels are composed of 3 playback DMA's, which are multi-channel DMA (32 bits, 8 channels, 192k), S/PDIF DMA (32 bits, 2 channels, 192k), and front panel DMA (16 bits, 2 channels, 48k). The 8 input channels are spread across 3 recording DMA's (32 bits, 192k) - recording A, B, and C DMA's. The architecture of recording is a unique point of CMI8788 that enables very flexible recording options for the user. The details of the recording mode selection will be explained in the later sections.

The CMI8788 is compatible with all the popular codecs, from I2S codecs with over 120dB quality to the usual AC97 codecs. This ability gives customers the flexibility to design their products exactly the way they want them. The I2S, AC-Link, 2-wire master bus, and SPI interfaces are used to transfer audio data and control data between the CMI8788 and codecs. To facilitate the connection with existing home audio electronics, the CMI8788 has incorporated the S/PDIF transmitter and receiver with 192k sampling rate. An EEPROM interface is built for the CMI8788 in connection with the EEPROM to store and retrieve the non-evaporable data for customer applications, such as board configuration, sub-vendor and sub-system IDs of the PCI configuration, or any dynamic data that customers want to restore at the next power-on. The CMI8788 has an independent 2-wire slave bus to communicate with the micro control unit (MCU). This interface is used as a medium for the system driver and the MCU to exchange data. One of the applications of the 2-wire slave bus is to transmit the control data from the remote controller to the system driver. The MPU-401 MIDI UART is also integrated in the CMI8788.

There are six GPI phone jack detect pins in CMI8788, which can be used to distinguish if a cable is plugged in the phone jack. There are 9 GPIO pins on the chip, however some of them are shared with other functions. The C-Media's unique device sensing technology is implemented in CMI8788, which can indicate whether a speaker or a headphone is plugged in the jack. Then according to this information, the system driver can decide to turn on the C-Media's X-ear 3D audio technology if appropriate.

## 2 Features

### 2.1 Hardware Features

- PCI 2.2 interface with bus mastering and burst modes
- Only one 24.576MHz oscillator is needed
- 4 synchronous I2S output data stream pairs within 1 flexible output DMA
- Programmable channel routing mechanism among the 4 I2S output pairs
- 4 synchronous I2S input data stream pairs spread in 3 input DMA's (for Dolby pro-audio applications)
- Optionally, a multi-channel AC-link can support 2 AC97 codecs 8 channel DAC output with 16 bit resolution

# Oxygen™HD CMI8788

High Performance PCI Audio Processor



- Programmable HW monitoring routing from I2S inputs to outputs
- All I2S I/O pairs support 32-bit PCM data transfer and adjustable sample rate (up to 192KHz)
- Integrated 192k/24-bit S/PDIF transmitter with 1 dedicated S/PDIF OUT DMA
- Integrated 192k/24-bit S/PDIF receiver in recording DMA
- S/PDIF IN supports digital loopback path for switching between optical and RCA connections
- 48k/16-bit front panel DMA for AC97 codec
- 2-wire master serial bus or 4-wire SPI (Serial Peripheral Interface) bus to control I2S codecs
- 2-wire slave serial bus to communicate with microcontroller unit (MCU)
- Interrupt pin to inform external MCU to retrieve the data from the system driver
- One MPU-401 MIDI UART port
- EEPROM control interface
- 6 GPI phone jack detection pins
- Advanced device-sensing technology indicates whether a speaker or a headphone is plugged in the jack
- 9 direct-access GPIO pins
- 3 bonding-option bits for 8 identification possibilities
- 128-pin LQFP thin high-quality package

## 2.2 Software Features

- DTS® Interactive – a real-time 5.1 channel encoder that takes 2 or more channels and encodes them into a DTS bit stream.
- DTS® NeoPC - an up-mix matrix that turns any 2 channel audio into 7.1 channel surround sound
- Dolby® Digital Live (AC-3) real-time 5.1 channel encoding bit-stream to facilitate the connection with CE AV receiver
- Dolby® Pro-Logic IIx surround processor, spreading stereo audio into 7.1 channel surround sound
- Renowned Dolby® Headphone technology, conveying 5.1 surround and 3D gaming audio over stereo headphones
- The latest Dolby® Virtual Speaker solution, creating amazing virtual surround sound from a generic two-speaker configuration
- C-Media FlexBass™ – configurable LFE channel crossover frequency (from 50 to 250Hz)
- C-Media Magic Voice™, a popular feature for disguising voice in online chatting
- C-Media Xear 3D™ 7.1 Virtual Speaker Shifter technology
- C-Media's unique Karaoke functions: Microphone Echo, Key-shifting
- Individual 10-band EQ for each channel
- 27 global reverberation environments
- Supports most industrial standards of 3D sound for PC gaming, including EAX™ 1.0&2.0, A3D™ 1.0,

# Oxygen™HD CMI8788

High Performance PCI Audio Processor



and DirectSound™

- Support 7.1 CH digital audio playback for WinXP, WinXP64, 2K, ME, 98SE (Microsoft® DirectX V.9.0 and above is required)
- ASIO function support
- Linux driver available (without Dolby® and DTS® technologies)

### 3 Applications

- Prosumer high-quality PCI sound card for retailer market
- Consumer sound card powered by Dolby® and DTS® technologies
- PC-based media center
- Professional PC musician application
- High-end motherboard requiring top audio quality
- Audio up-sell for PC systems
- Bundle selling with high-profile VGA cards
- General purpose multi-channel I/O

4 Block Diagram

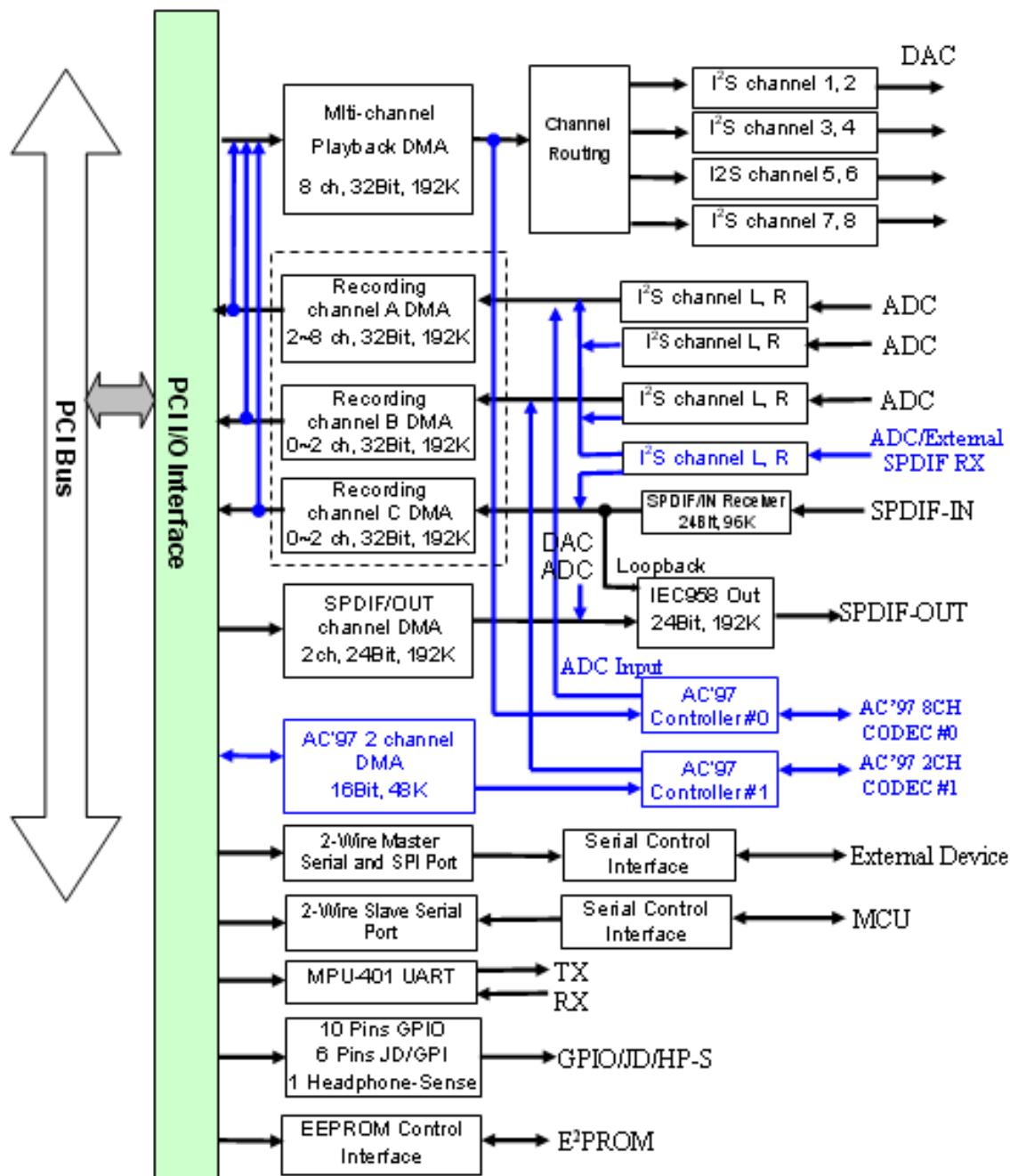

Figure 1. Block Diagram of Oxygen™HD CMI8788

## 5 Pin Assignment

### 5.1 Pin-out Diagram

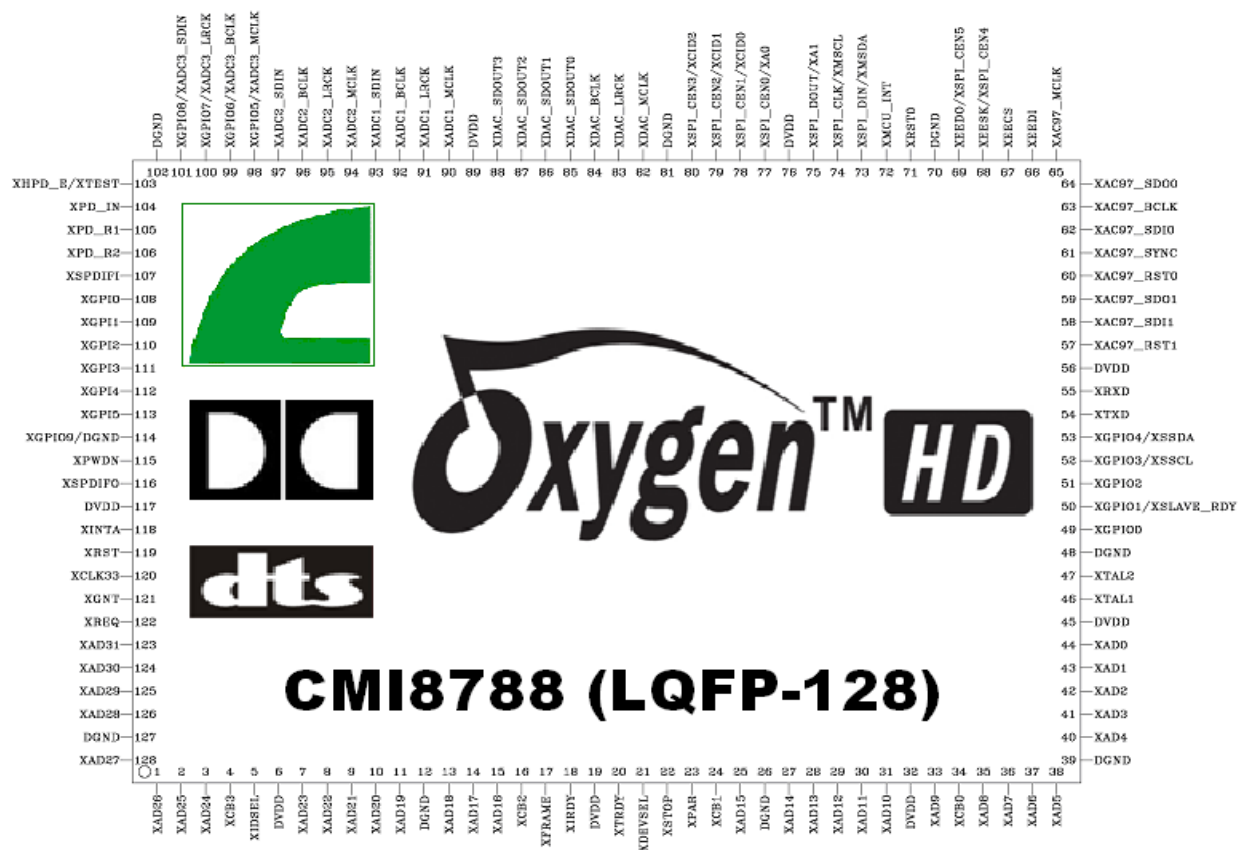

Figure 2. Pinout Diagram of Oxygen™HD CMI8788



### 5.2 Pin Descriptions

The following table gives the pin descriptions for the Oxygen™HD CMI8788. Some of the pins perform multiple functions, so for the sake of consistency, a pin may be listed more than once in the table. The abbreviations used in the pin description table are explained below.

**DI:** digital input signal

**DO:** digital output signal

**DIO:** digital bidirectional signal

**AI:** analog input

**PU:** pull-up with 75KΩ resistor

**PD:** pull-down with 75KΩ resistor

**#:** low active signal

Table 3.1 Pin description table of Oxygen™HD CMI8788

Symbol	Pin No.	Type	Description
<b>PCI Bus Interface</b>			
XRST	119	DI	PCI Bus Reset.
XCLK33	120	DI	PCI Bus clock, 33MHz.
XIDSEL	5	DI	PCI Initialization Device Select. This is the chip select during PCI configuration access.
XGNT#	121	DI	PCI Bus Grant. When active, PCI bus master is granted to CMI8788.
XREQ#	122	DIO	PCI Bus Master Request. When active, the CMI8788 is requesting to become a bus master.
XAD[31:0]	1-3, 7-11, 13-15, 25, 27, 28-31, 33, 35-38, 40-44, 123-126, 128	DIO	PCI Address / Data Bus
XCB#[3:0]	4, 16, 24, 34	DIO	PCI Bus Command / Byte Enable
XFRAME#	17	DIO	PCI Cycle Frame. It is driven by the current master to indicate the beginning and duration of an access
XDEVSEL#	21	DIO	PCI Device Select. When active, indicates that the driving device has decoded its address as the target of the current access.
XIRDY#	18	DIO	PCI Initiator Ready. When active, indicates that the initiator can complete the current data phase of the transaction.
XTRDY#	20	DIO	PCI Target Ready. When active, indicates the target device can complete the current data phase of the transaction.
XSTOP#	22	DIO	PCI Stop. When active, indicates that the target is requesting that the master stop the current transaction.
XPAR	23	DIO	PCI Parity. It is even parity across XAD[31:0] and XCB#[3:0].
XINTA#	118	DIO	PCI Interrupt Request A.

MPU-401 MIDI UART Interface			
XTXD	54	DIO, PU	MP-401 MIDI transmitter (output). It is also used as XGPIO5-8 and I2S ADC 3 configuration (input, 0: GPIO5-8, 1: I2S ADC 3) at the rising edge of XRST.
XRXD	55	DI, PU	MPU401 MIDI receiver.
I2S Interface			
XDAC_MCLK	82	DO	I2S DAC master clock output.
XDAC_LRCK	83	DIO	I2S DAC Left/Right sample clock.
XDAC_BCLK	84	DIO	I2S DAC bit clock.
XDAC_SDOUT0	85	DO	I2S DAC channel 0,channel 1 serial data output.
XDAC_SDOUT1	86	DO	I2S DAC channel 2,channel 3 serial data output.
XDAC_SDOUT2	87	DO	I2S DAC channel 4,channel 5 serial data output.
XDAC_SDOUT3	88	DO	I2S DAC channel 6,channel 7 serial data output.
XADC1_MCLK	90	DO	I2S ADC 1 and I2S ADC 4 master clock output.
XADC1_LRCK	91	DIO	I2S ADC 1 Left/Right sample clock.
XADC1_BCLK	92	DIO	I2S ADC 1 bit clock.
XADC1_SDIN	93	DI, PU	I2S ADC 1 serial data input.
XAC97_SD11/ XADC1_SDIN1	58	DI, PD	I2S ADC 1 serial data input 1. This pin is shared with AC97 serial data input 1, and determined by XSPI_DOUT/XA1 input configuration at the rising edge of XRST.
XADC2_MCLK	94	DO	I2S ADC 2 master clock output.
XADC2_LRCK	95	DIO	I2S ADC 2 Left/Right sample clock.
XADC2_BCLK	96	DIO	I2S ADC 2 bit clock.
XADC2_SDIN	97	DI, PU	I2S ADC 2 serial data input.
XGPIO5/ XADC3_MCLK	98	DIO, PD	I2S ADC 3 master clock output. This pin is shared with XGPIO5, which is determined by XTXD input configuration at the rising edge of XRST.
XGPIO6/ XADC3_BCLK	99	DIO, PD	I2S ADC 3 bit clock. This pin is shared with XGPIO6, which is determined by XTXD input configuration at the rising edge of XRST.
XGPIO7/ XADC3_LRCK	100	DIO, PD	I2S ADC 2 Left/Right sample clock. This pin is shared with XGPIO7, which is determined by XTXD input configuration at the rising edge of XRST.
XGPIO8/ XADC3_SDIN	101	DIO, PD	GPIO8, default input. This pin is shared with XADC3_SDIN, which determined by XTXD input configuration at the rising edge of XRST.
AC-Link Interface			
XAC97_BCLK	63	DI, PU	AC97 serial clock input8
XAC97_SDIO	62	DI, PD	AC97 serial data input 0
XAC97_SD11/ XADC1_SDIN1	58	DI, PD	AC97 serial data input 1. This pin is shared with XADC1_SDIN1, and determined by XSPI_DOUT/XA1 input configuration at the rising edge of XRST.
XAC97_SYNC	61	DO	AC97 frame synchronization.

XAC97_SDO0	64	DO	AC97 serial data output 0.
XAC97_SDO1	59	DO	AC97 serial data output 1.
XAC97_RST0	60	DO	AC97 codec reset 0.
XAC97_RST1	57	DO	AC97 codec reset 1.
XAC97_MCLK	65	DO	AC97 master clock 24.5760M for AC97 codec.
<b>Serial Port Interface</b>			
XSPI_DIN/ XMSDA	73	DIO, PU	SPI data input. This pin is shared with 2-wire master serial data.
XSPI_CLK/ XMSCL	74	DIO, PU	SPI clock output. This pin is shared with 2-wire master serial clock.
XSPI_DOUT/ XA1	75	DIO, PU	SPI data output. This pin is shared with 2-wire Codec address A1. It is also used as XAC97_SDI1 and XADC1_SDIN1 configuration at the rising edge of XRST (input, 1: XAC97_SDI1, 0: XADC1_SDIN1).
XSPI_CEN0/ XA0	77	DIO, PU	SPI chip enable, which select the codec #0 to be controlled. It is shared with I2C Codec address A0. It is also used as XGPIO3-4 and SSCL/SSDA configuration (input, 1: GPIO3-4, 0: SSCL/SSDA) at the rising edge of XRST.
XSPI_CEN1/ XCID0	78	DIO, PU	SPI chip enable, which select the codec #1 to be controlled (output). It is shared with codec ID 0 configuration (input) at the rising edge of XRST.
XSPI_CEN2/ XCID1	79	DIO, PU	SPI chip enable, which select the codec #2 to be controlled (output). It is shared with codec ID 1 configuration (input) at the rising edge of XRST.
XSPI_CEN3/ XCID2	80	DIO, PU	SPI chip enable, which select the codec #3 to be controlled (output). It is shared with codec ID 2 configuration (input) at the rising edge of XRST.
XSPI_CEN4/ XEESK	68	DO	SPI chip enable, which select the codec #4 to be controlled. It is shared with EEPROM serial clock.
XSPI_CEN5/ XEEDO	69	DO	SPI chip enable, which select the codec #5 to be controlled. It is shared with EEPROM serial data out.
<b>2-Wire Master Serial Bus</b>			
XMSDA/ XSPI_DIN	73	DIO, PU	2-wire serial bus data. This pin is shared with SPI data input.
XMSCL/ XSPI_CLK	74	DIO, PU	2-wire serial bus clock. This pin is shared with SPI clock output.
XA1/ XSPI_DOUT	75	DIO, PU	2-wire serial bus codec address A1. This pin is shared with SPI data output. It is also used as XAC97_SDI1 and XADC1_SDIN1 configuration at the rising edge of XRST (input, 1: XAC97_SDI1, 0: XADC1_SDIN1).
XA0/ XSPI_CEN0	77	DIO, PU	2-wire serial bus codec address A0. This pin is shared with SPI chip enable, which select the codec #0 to be controlled. It is also used as XGPIO3-4 and SSCL/SSDA configuration (input, 1: GPIO3-4, 0: SSCL/SSDA) at the rising edge of XRST.

2-Wire Slave Serial Bus			
XSSCL/ XGPIO3	52	DIO, PU	2-wire serial bus clock. This pin is shared with XGPIO3.
XSSDA/ XGPIO4	53	DIO, PU	2-wire serial bus data. This pin is shared with XGPIO4.
XMCU_INT	72	DO	Interrupt output for external Micro Control Unit (MCU).
XSLAVE_RDY/ XGPIO1	50	DIO, PD	2-wire serial bus data ready. This pin is shared with XGPIO1.
S/PDIF Interface			
XSPDIFI	107	DI	S/PDIF receiver.
XSPDIFO	116	DO	S/PDIF transmitter.
EEPROM Interface			
XEECS	67	DIO, PD	EEPROM chip enable (output). It is also used as power on EEPROM CS delay configuration (input, 0: no delay, 1: delay 1 clock) at the rising edge of XRST
XEESK/ XSPI_CEN4	68	DO	EEPROM serial clock. This pin is shared with SPI chip enable, which select the codec #4 to be controlled
XEEDI	66	DI, PU	EEPROM serial data in
XEEDO/ XSPI_CEN5	69	DO	EEPROM serial data out. This pin is shared with SPI chip enable, which select the codec #5 to be controlled
Jack Detect GPI Interface			
XGPIO0	108	DI, PD	JACK A detection input
XGPIO1	109	DI, PD	JACK B detection input
XGPIO2	110	DI, PD	JACK C detection input
XGPIO3	111	DI, PD	JACK D detection input
XGPIO4	112	DI, PD	JACK E detection input
XGPIO5	113	DI, PD	JACK F detection input
GPIO Interface			
XGPIO0	49	DIO, PD	GPIO0, default output Low.
XGPIO1/ XSLAVE_RDY	50	DIO, PD	GPIO1, default output Low. This pin is shared with I2C Slave data ready.
XGPIO2	51	DIO, PD	GPIO2, default input.
XGPIO3/XSSCL	52	DIO, PU	GPIO3, default output Low. This pin is shared with I2C Slave serial clock.
XGPIO4/XSSDA	53	DIO, PU	GPIO4, default input. This pin is shared with I2C Slave serial data
XGPIO5/ XADC3_MCLK	98	DIO, PD	GPIO5, default output Low. This pin is shared with XADC3_MCLK, which determined by XTXD input configuration at the rising edge of XRST.

XGPIO6/ XADC3_BCLK	99	DIO, PD	GPIO6, default input. This pin is shared with XADC3_BCLK, which determined by XTXD input configuration at the rising edge of XRST.
XGPIO7/ XADC3_LRCK	100	DIO, PD	GPIO7, default output Low. This pin is shared with XADC3_LRCK, which determined by XTXD input configuration at the rising edge of XRST.
XGPIO8/ XADC3_SDIN	101	DIO, PD	GPIO8, default input. This pin is shared with XADC3_SDIN, which determined by XTXD input configuration at the rising edge of XRST.
<b>Headphone Sensing Interface</b>			
XHPD_E/ XTEST	103	DIO, PD	Head phone detect enable. This pin is shared with test mode selection at the rising edge of XRST
XHPD_IN	104	AI	Head phone voltage input
XHPD_R1	105	AI	Head phone reference resistor 1
XHPD_R2	106	AI	Head phone reference resistor 2
<b>Miscellaneous</b>			
XTAL1	46	DI	24.576Mhz OSC input
XTAL2	47	DO	OSC output
XRSTO	71	DO	External Codec reset, can be programmed as Active Low or High with Register 0x50-bit 2
XPWDN	115	DO	Power Down output pin, Active Low, default High
DVDD	6, 19, 32, 45, 56, 76, 89, 117		3.3V power input
DGND	12, 26, 39, 48, 70, 81, 102, 114		Ground

## 6 Electrical Characteristics

### 6.1 Maximum Ratings

Test Conditions

DVDD = 3.3V, DGND =0V, TA=+25°C

Parameter	Symbol	Min	Typ	Max	Units
Storage temperature	-	-55	-	150	°C
Operating ambient temperature	-	0	25	75	°C
DC supply voltage	-	3.0	3.3	3.6	V
I/O pin voltage	-	GND	-	V <sub>DD</sub>	V
Power dissipation	-	-	0.15	-	W

### 6.2 Recommended Operation Conditions

Test Conditions

DVDD = 3.3V, DGND =0V, TA=+25°C

Parameter	Symbol	Min	Typ	Max	Units
Input voltage range	-	V <sub>DD</sub> -0.3	V <sub>DD</sub>	V <sub>DD</sub> +0.3	V
Output voltage range	-	0	-	V <sub>DD</sub>	V

### 6.3 Power Consumption

Test Conditions

DVDD = 3.3V, DGND =0V, TA=+25°C

Parameter	Symbol	Min	Typ	Max	Units
Supply current : power up	-	-	40	-	mA
Supply current : power down	-	-	10	-	uA

### 6.4 DC Characteristics

Test Conditions

DVDD = 3.3V, DGND =0V, TA=+25°C

Parameter	Symbol	Min	Typ	Max	Units
Input voltage range	V <sub>in</sub>	V <sub>DD</sub> -0.3	V <sub>DD</sub>	V <sub>DD</sub> +0.3	V
Output voltage range	V <sub>out</sub>	0	-	V <sub>DD</sub>	V
High level input voltage	V <sub>ih</sub>	0.7V <sub>DD</sub>	-	-	V
Low level input voltage	V <sub>il</sub>	-	-	0.3V <sub>DD</sub>	V
High level output voltage	V <sub>oh</sub>	2.4	-	-	V
Low level output voltage	V <sub>ol</sub>	-	-	0.4	V
Input leakage current	I <sub>il</sub>	-10	-	10	uA
Output leakage current	I <sub>ol</sub>	-10	-	10	uA
Output buffer driver current	-	-	8	-	mA
SPDIF transmit output driver current	-	-	8	-	mA

### 6.5 AC Timing Characteristics

#### 6.5.1 I2S Signal Timing

##### a. System Clock Timing

System Clock Timing Diagram

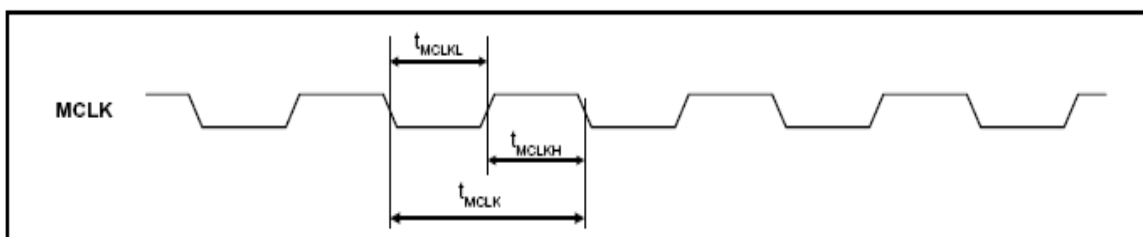

Test Conditions

DVDD = 3.3V, DGND = 0V, TA = +25°C, fs = 96 KHz, MCLK = 512fs, 24 bit data, unless otherwise stated

System Clock Timing Parameters

Parameter	Symbol	Min	Typ	Max	Units
MCLK clock cycle time	tmclk	20	-	-	ns
MCLK pulse width high	tmclkh	10	-	-	ns
MCLK pulse width low	tmckll	10	-	-	ns
MCLK duty cycle		40	50	60	%

##### b. Audio Interface Timing

Audio Interface Timing Diagram

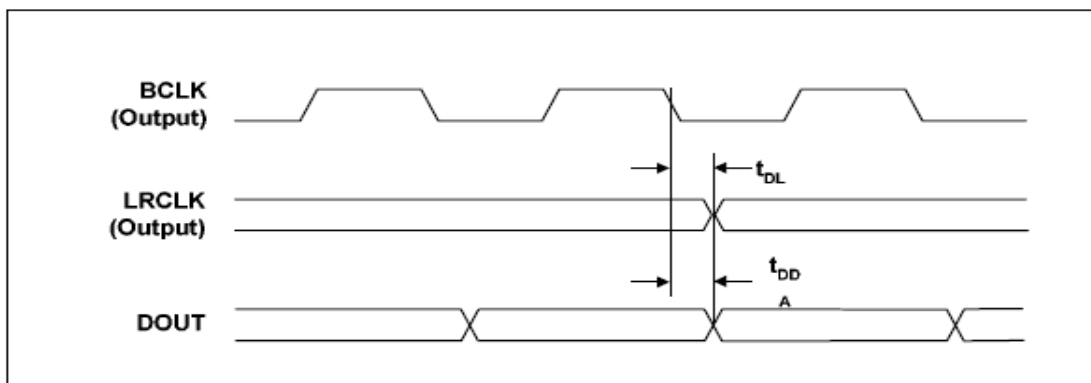

Test Conditions

DVDD = 3.3V, DGND = 0V, TA = +25°C, fs = 96 KHz, MCLK = 512fs, 24 bit data, unless otherwise stated

Audio Interface Timing Parameters

Parameter	Symbol	Min	Typ	Max	Units
LRCLK propagation delay from BCLK falling edge	Tdl	5	-	-	ns
SDOUT propagation delay from BCLK falling edge	Tdd	5	-	-	ns

### 6.5.2 Control Interface Timing - 3 - Wire Mode

Control Interface Timing -3- Wire Diagram

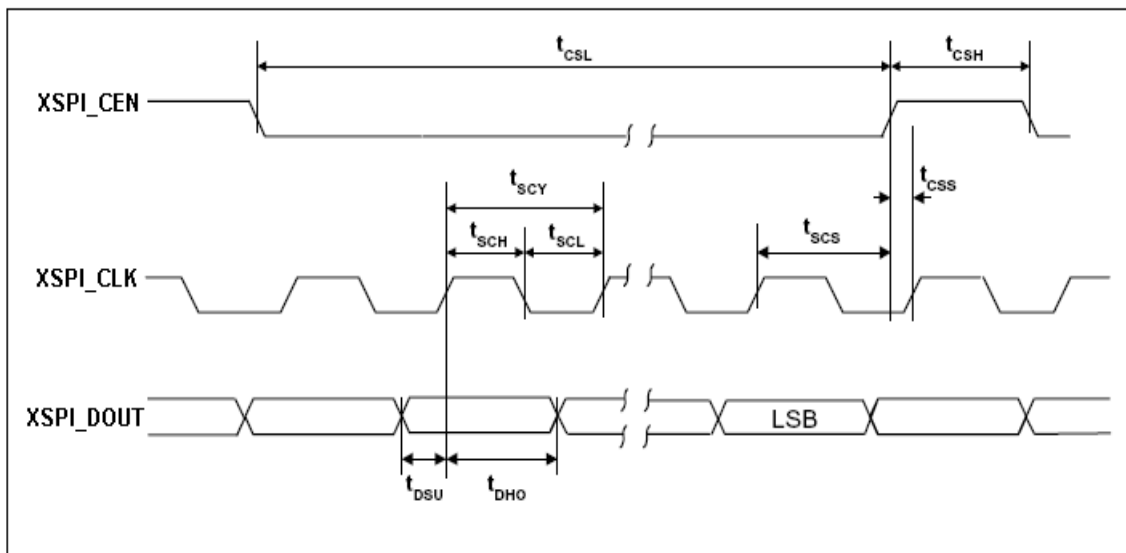

Note: latch data at XSPI\_CEN clock low mode, XSPI\_CEN clock can be low or high mode

#### Test Conditions

DVDD = 3.3V, DGND = 0V, TA = +25°C, SPI clock 160 ns, unless otherwise stated

Control Interface Timing -3- Wire Parameters

Parameter	Symbol	Min	Typ	Max	Units
XSPI_CLK rising edge to XSPI_CEN rising edge	Tscs	120	-	-	ns
XSPI_CLK pulse cycle time	Tscy	160	-	-	ns
XSPI_CLK pulse width low	Tscl	80	-	-	ns
XSPI_CLK pulse width high	Tsch	80	-	-	ns
XSPI_DOUT to XSPI_CLK set-up time	Tdsu	40	-	-	ns
XSPI_DOUT to XSPI_CLK hold time	Tdho	40	-	-	ns
XSPI_CEN rising to SCLK rising	Tcss	40	-	-	ns



### 6.5.3 Control Interface Timing - 2 - Wire Mode

Control Interface Timing -2- Wire Diagram

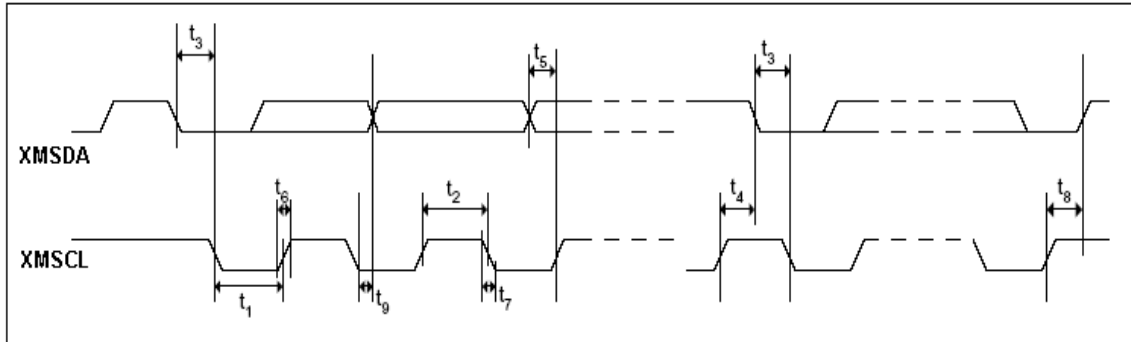

**Test Conditions**

DVDD = 3.3V, DGND = 0V, TA = +25°C, 2 wire, Fast speed mode, unless otherwise stated

Control Interface Timing -2- Wire Parameters

Parameter	Symbol	Min	Typ	Max	Units
XMSCL frequency		400	-	-	KHz
XMSCL pulse width low	t1	650	-	-	ns
XMSCL pulse width high	t2	1.3	-	-	us
Hold time (start condition)	t3	650	-	-	ns
Set-up time (start condition)	t4	650	-	-	ns
Data set-up time	t5	650	-	-	ns
XMSDI, XMSCL rise time	t6	100	-	-	ns
XMSDI, XMSCL fall time	t7	100	-	-	ns
Set-up time (stop condition)	t8	650	-	-	ns
Data hold time	t9	650	-	-	ns

Note: test parameters at 2 wire, Fast speed mode

## 6.5.4 EEPROM Interface Timing

EEPROM Interface Timing Diagram

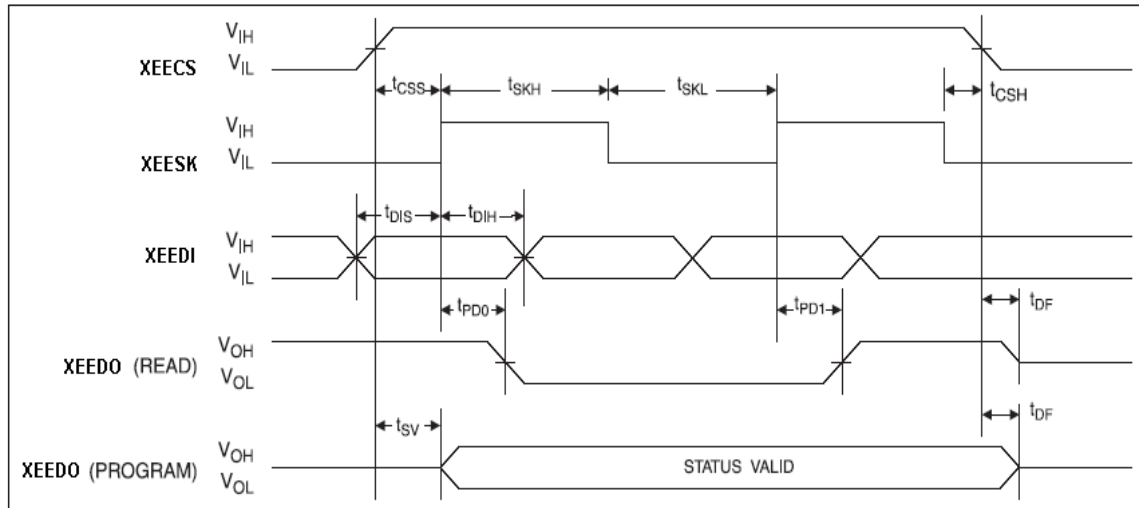

### Test Conditions

DVDD = 3.3V, DGND = 0V, TA = +25°C, unless otherwise stated

EEPROM Interface Timing Parameters

Parameter	Symbol	Min	Typ	Max	Units
XEESK clock frequency	tsk	555	-	-	KHz
XEESK high time	tskh	900	-	-	ns
XEESK low time	tskl	900	-	-	ns
XEECS setup time	tcss	900	-	-	ns
XEEDI setup time	tdis	900	-	-	ns
XEESK hold time	tcsh	900	-	-	ns
XEEDI hold time	tdih	2	-	-	ns
Output delay to "1"	tpd1	900	-	-	ns
Output delay to "0"	tpd0	30	-	-	ns
XEECS to status valid	tsv	30	-	-	ns
XEECS to XEEDO in high impedance	tdf	30	-	-	ns

### 6.5.5 EEPROM AC Timing Characteristics

Symbol	Description	Min	Max	Units
fsk	SK Clock Frequency	0	0.5	MHz
tskh	SK High Time	500		ns
tskl	SK Low Time	500		ns
tcss	CS Setup Time	100		ns
tcsh	CS Hold Time	0		ns
tdis	DI Setup Time	200		ns
tdih	DI Hold Time	200		ns
tpd0	Output Delay to "0"		500	ns
tpd1	Output Delay to "1"		500	ns
tsv	CS to Status Valid		500	ns
tdf	CS to DO High Impedance		200	ns

### 6.5.6 AC-Link Timing Characteristics:

#### Test Conditions

DVDD = 3.3V, DGND = 0V, TA = +25°C, unless otherwise stated

#### 1. Cold Rest

Cold Reset Timing Diagram

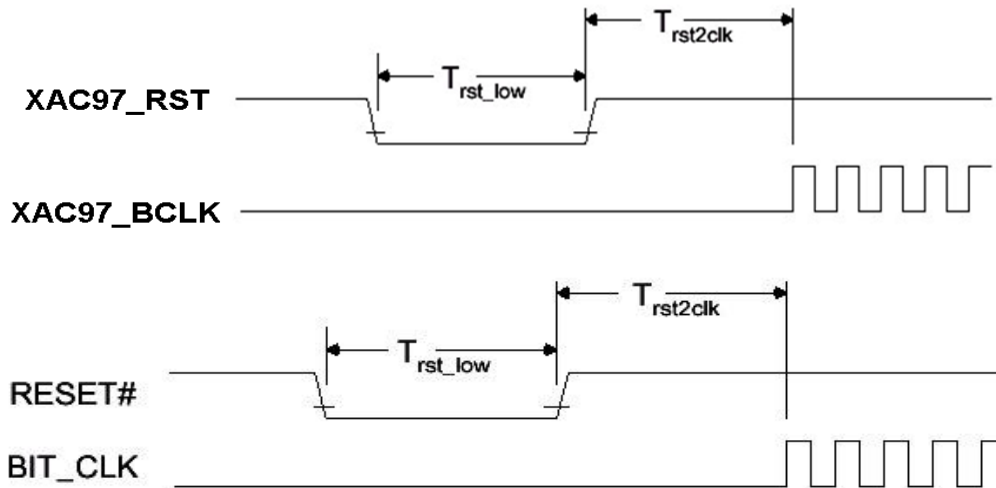

Cold Reset Timing Parameters

Parameter	Symbol	Min	Typ	Max	Units
XAC97_RST active low pulse width	Trst_low	1.7	-	-	us
XAC97_RST inactive to XAC97_BCLK startup delay	Trst2clk	168	-	-	ns

# denotes active low.

### 2. Warm Reset

Warm Reset Diagram

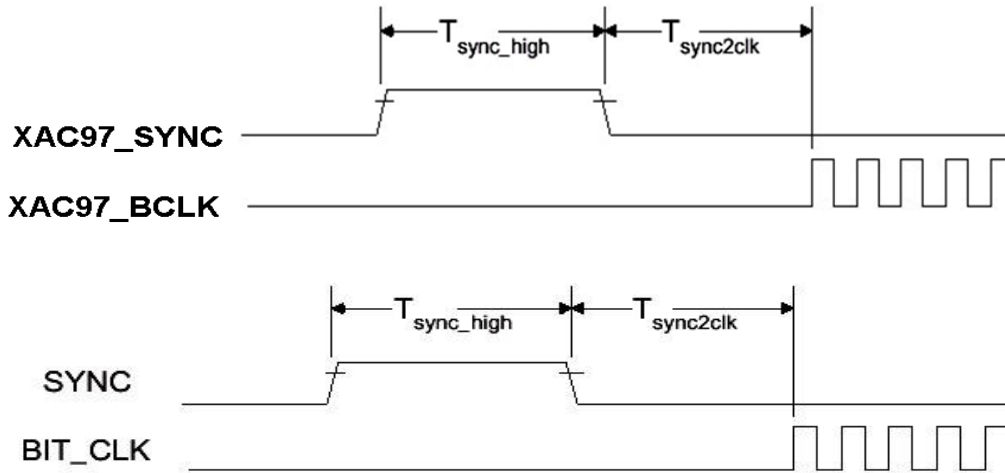

Warm Reset Parameters

Parameter	Symbol	Min	Typ	Max	Units
XAC97_SYNC active high pulse width	$T_{sync\_high}$	1.2	-	-	us
XAC97_SYNC inactive to XAC97_BCLK startup delay	$T_{sync2clk}$	168	-	-	ns

### 3. AC-Link Clocks

BIT\_CLK to SYNC Timing Diagram

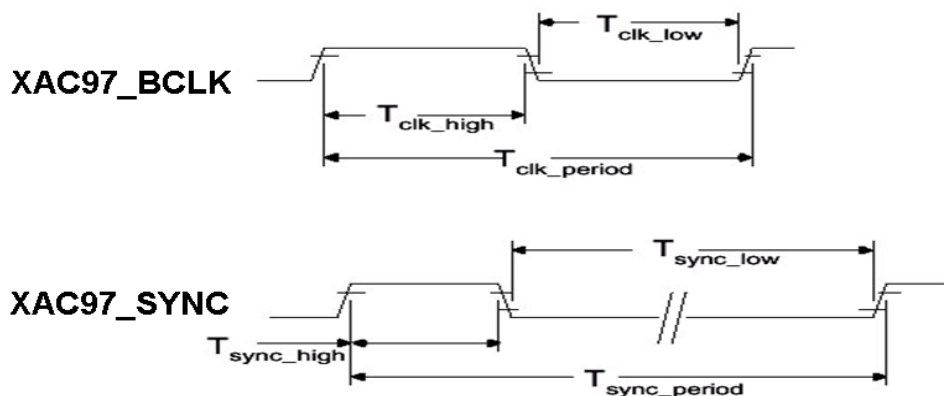

### BIT\_CLK to SYNC Timing Parameters

Parameter	Symbol	Min	Typ	Max	Units
XAC97_BCLK frequency		12.288	-	-	MHz
XAC97_BCLK period	Tclk_period	81.4	-	-	ns
XAC97_BCLK output jitter		750	-	-	ps
XAC97_BCLK high pulsewidth (note 1)	Tclk_high	40.7	-	-	ns
XAC97_BCLK low pulse width (note 1)	Tclk_low	40.7	-	-	ns
XAC97_SYNC frequency		48.0	-	-	kHz
XAC97_SYNC period	Tsync_period	20.8	-	-	us
XAC97_SYNC high pulse width	Tsync_high	1.3	-	-	us
XAC97_SYNC low_pulse width	Tsync_low	19.5	-	-	us

Note: Worst case duty cycle restricted to 45/55.

#### 4. Data Setup and Hold

Data Setup and Hold diagram

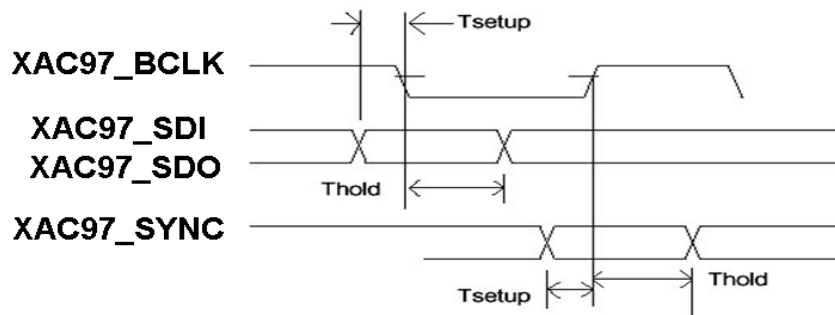

Data Setup and Hold Parameters

Parameter	Symbol	Min	Typ	Max	Units
Setup to falling edge of XAC97_BCLK	Tsetup	30	-	-	ns
Hold from falling edge of XAC97_BCLK	Thold	30	-	-	ns

Note: Setup and hold time parameters for SDATA\_IN are with respect to the AC '97 Controller.

## 5. Signal Rising and Falling Times

Signal Rising and Falling Times Diagram

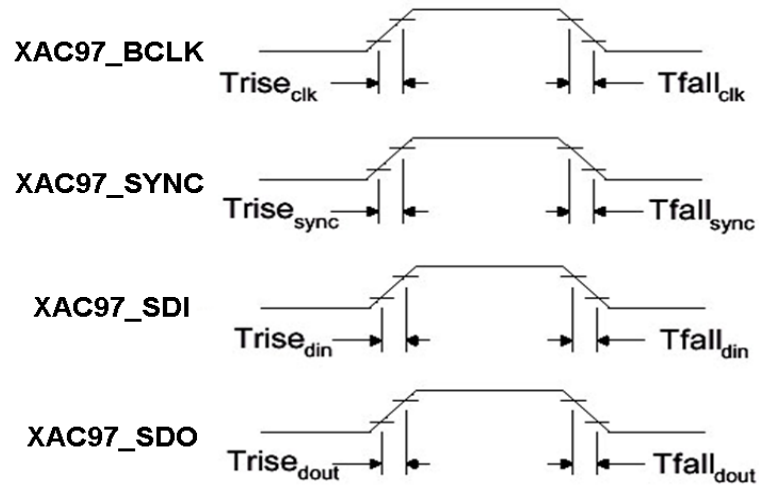

Signal Rising and Falling time Parameters

Parameter	Symbol	Min	Typ	Max	Units
XAC97_BCLK rising time	Triseclk	6	-	-	ns
XAC97_BCLK falling time	Tfallclk	6	-	-	ns
XAC97_SYNC rising time	Trisesync	6	-	-	ns
XAC97_SYNC falling time	Tfallsync	6	-	-	ns
XAC97_SDI rising time	Trisedin	6	-	-	ns
XAC97_SDI falling time	Tfalldin	6	-	-	ns
XAC97_SDO rising time	Trisedout	6	-	-	ns
XAC97_SDO falling time	Tfalldout	6	-	-	ns

# Oxygen™HD CMI8788

High Performance PCI Audio Processor



## 7 Mechanical Specification

### 7.1 Package Dimension

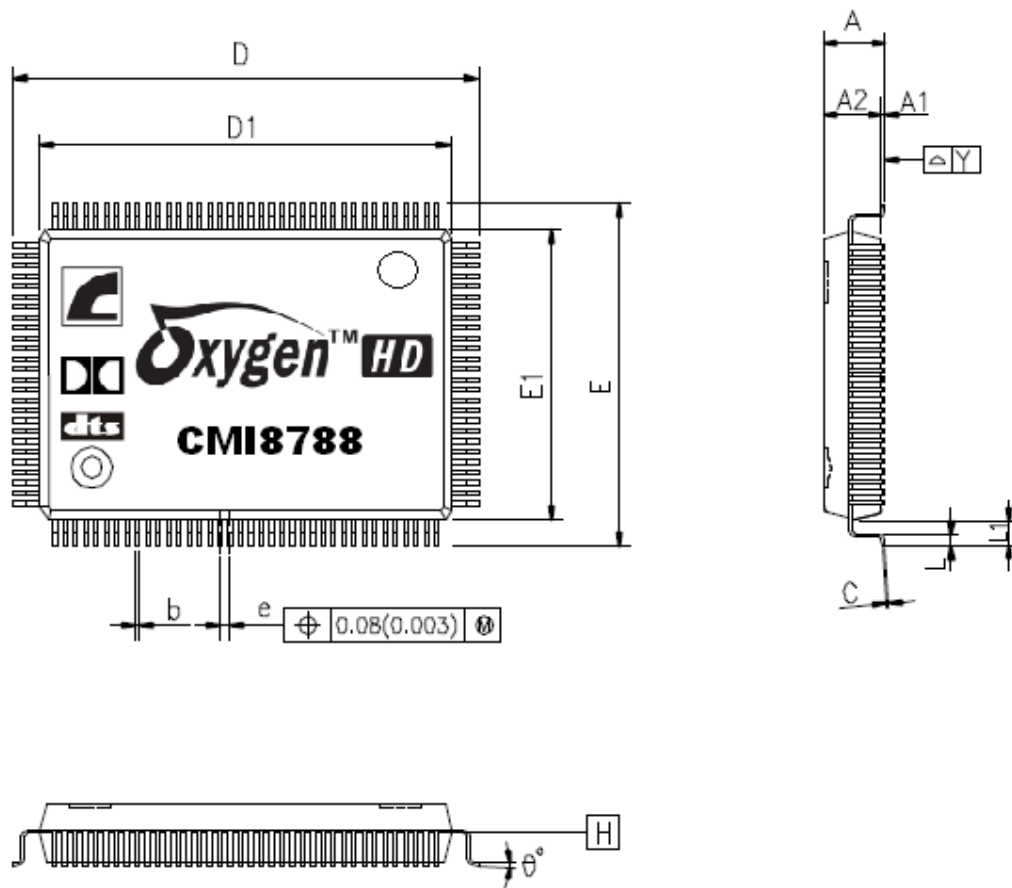

SYMBOLS	MIN.	NOM.	MAX.
A	—	—	1.60
A1	0.05	—	0.15
A2	1.35	1.40	1.45
b	0.17	0.22	0.27
c	0.10	0.15	0.20
D1	—	20.00 BSC	—
E1	—	14.00 BSC	—
e	—	0.50 BSC	—
D	—	22.00 BSC	—
E	—	16.00 BSC	—
L	0.45	0.60	0.75
L1	—	1.00 REF	—
Y	—	—	0.08
θ°	0°	3.5°	7°

UNIT : mm

#### NOTES.

1. JEDEC OUTLINE MS-026 BHB
2. DATUM PLANE [H] IS LOCATED AT THE BOTTOM OF THE MOLD PARTING LINE COINCIDENT WITH WHERE THE LEAD EXITS THE BODY.
3. DIMENSIONS E1 AND D1 DO NOT INCLUDE MOLD PROTRUSION. ALLOWABLE PROTRUSION IS 0.25 mm PER SIDE. DIMENSIONS E AND E DO INCLUDE MOLD MISMATCH AND ARE DETERMINED AT DATUM PLANE [H].
4. DIMENSION b DOES NOT INCLUDE DAMBAR PROTRUSION.



— End of Specifications —

**C-MEDIA ELECTRONICS INC.**

6F., 100, Sec. 4, Civil Boulevard, Taipei, Taiwan 106 R.O.C.

TEL : +886-2-8773-1100

FAX : +886-2-8773-2211

E-MAIL : [sales@cmedia.com.tw](mailto:sales@cmedia.com.tw)

**Disclaimer:**

Information furnished by C-Media Electronics Inc. is believed to be accurate and reliable. However, no responsibility is assumed by C-Media Electronics Inc. for its use, nor for any infringements of patents or other rights of third parties that may result from its use. Specifications subject to change without notice. No license is granted by implication or otherwise under any patent or patent rights of C-Media. Trademark and registered trademark are the property of their respective owners.

---