

CMOD2005
SURFACE MOUNT
HIGH VOLTAGE
SILICON SWITCHING DIODE



www.centrasemi.com

DESCRIPTION:

The CENTRAL SEMICONDUCTOR CMOD2005 is a Silicon Switching Diode, manufactured by the epitaxial planar process, epoxy molded in a SOD-523 surface mount package, designed for applications requiring high voltage capability.

ULTRAmiTM



SOD-523 CASE

MARKING CODE: 25

MAXIMUM RATINGS: ($T_A=25^\circ\text{C}$)

	SYMBOL		UNITS
Continuous Reverse Voltage	V_R	300	V
Peak Repetitive Reverse Voltage	V_{RRM}	350	V
Average Forward Current	I_O	200	mA
Continuous Forward Current ($T_L=90^\circ\text{C}$)	I_F	250	mA
Peak Repetitive Forward Current, $t_p=1.0\text{ms}$	I_{FRM}	1.0	A
Peak Forward Surge Current, $t_p=1.0\mu\text{s}$	I_{FSM}	4.5	A
Power Dissipation	P_D	250	mW
Power Dissipation ($T_L=90^\circ\text{C}$)	P_D	500	mW
Operating and Storage Junction Temperature	T_J, T_{stg}	-65 to +150	$^\circ\text{C}$
Thermal Resistance	θ_{JA}	500	$^\circ\text{C/W}$
Thermal Resistance	θ_{JL}	120	$^\circ\text{C/W}$

ELECTRICAL CHARACTERISTICS: ($T_A=25^\circ\text{C}$ unless otherwise noted)

SYMBOL	TEST CONDITIONS	MIN	MAX	UNITS
I_R	$V_R=280\text{V}$		100	nA
I_R	$V_R=280\text{V}, T_A=150^\circ\text{C}$		100	μA
BV_R	$I_R=100\mu\text{A}$	350		V
V_F	$I_F=20\text{mA}$		0.87	V
V_F	$I_F=100\text{mA}$		1.0	V
V_F	$I_F=200\text{mA}$		1.25	V
C_T	$V_R=0, f=1.0\text{MHz}$		5.0	pF
t_{rr}	$I_R=I_F=30\text{mA}, I_{rr}=3.0\text{mA}, R_L=100\Omega$		50	ns

R1 (24-June 2010)

CMOD2005
SURFACE MOUNT
HIGH VOLTAGE
SILICON SWITCHING DIODE



SOD-523 CASE - MECHANICAL OUTLINE

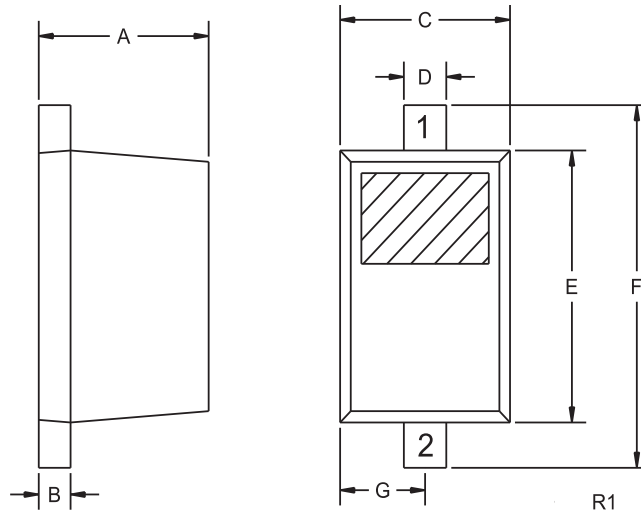

LEAD CODE:

- 1) Cathode
- 2) Anode

MARKING CODE: 25

SYMBOL	INCHES		MILLIMETERS	
	MIN	MAX	MIN	MAX
A	0.020	0.031	0.50	0.80
B	0.004	0.008	0.10	0.20
C	0.028	0.035	0.70	0.90
D	0.008	0.011	0.20	0.28
E	0.039	0.055	1.00	1.40
F	0.055	0.071	1.40	1.80
G	0.016		0.40	

SOD-523 (REV: R1)

R1 (24-June 2010)

www.centrasemi.com

www.DataSheet4U.com