

240 – 960 MHz (G)FSK/OOK Stand-Alone Transmitter with Encoder

Features

- Embedded EEPROM
 - Very Easy Development with RFPDK
 - All Features Programmable
- Frequency Range: 240 to 960 MHz
- FSK, GFSK and OOK Modulation
- Symbol Rate:
 - 0.5 to 100 ksps (FSK/GFSK)
 - 0.5 to 40 ksps (OOK)
- Deviation: 1.0 to 200 kHz
- Output Power: -10 to +13 dBm
- Sleep Current: < 20 nA
- Stand-Alone, No External MCU Control Required
- Embedded 1920, 1527 and 2262 Data Encoder
- Up to 7 Configurable Data Pins for Push Buttons
- LED Indicator for Low Battery Detection and Transmission
- Sync ID Auto-Study with CMOSTEK Receiver
- FCC / ETSI Compliant
- RoHS Compliant
- 14-pin SOP Package

Descriptions

The CMT2157A is a true single-chip, highly flexible, high performance, (G)FSK/OOK RF transmitter with embedded data encoder ideally for 240 to 960 MHz wireless applications. The device integrates a data encoder that is not only compatible with the most common used encoding format of 1527 and 2262, but also a more efficient, flexible and powerful format of 1920 designed by CMOSTEK. Up to 7 configurable push buttons are supported in multiple button modes. When pairing the device to CMOSTEK receiver, the synchronization ID can be programmed into both of the transmitter and receiver during the manufacturing phase, or studied by the receiver from the transmitter remotely by end customers. An embedded EEPROM allows the RF and encoder parameters to be programmed into the chip using the CMOSTEK USB Programmer and the RFPDK. Alternatively, in stock product of 868.35 MHz is available for immediate demands without the need of EEPROM programming. The CMT2157A is part of the CMOSTEK NextGenRF™ family, together with CMT225x series receivers, they enable ultra low cost, low power consumption RF links.

Applications

- Low-Cost Consumer Electronics Applications
- Home and Building Automation
- Remote Fan Controllers
- Infrared Transmitter Replacements
- Industrial Monitoring and Controls
- Remote Lighting Control
- Wireless Alarm and Security Systems
- Remote Keyless Entry (RKE)

Ordering Information

Part Number	Frequency	Package	MOQ
CMT2157A-ESR	868.35 MHz	T&R	2,500 pcs
CMT2157A-ESB	868.35 MHz	Tube	1,000 pcs

More Ordering Info: See [Page 26](#)

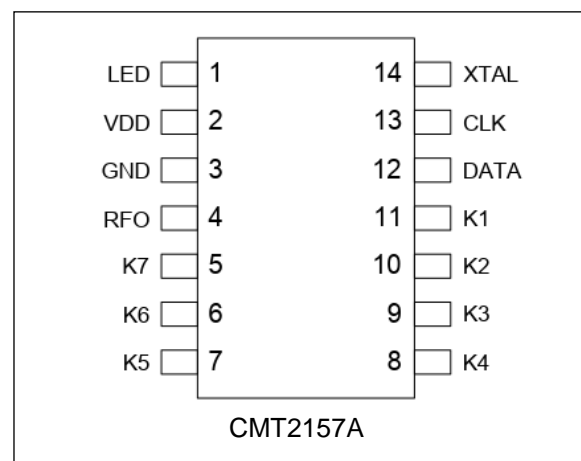

Typical Application

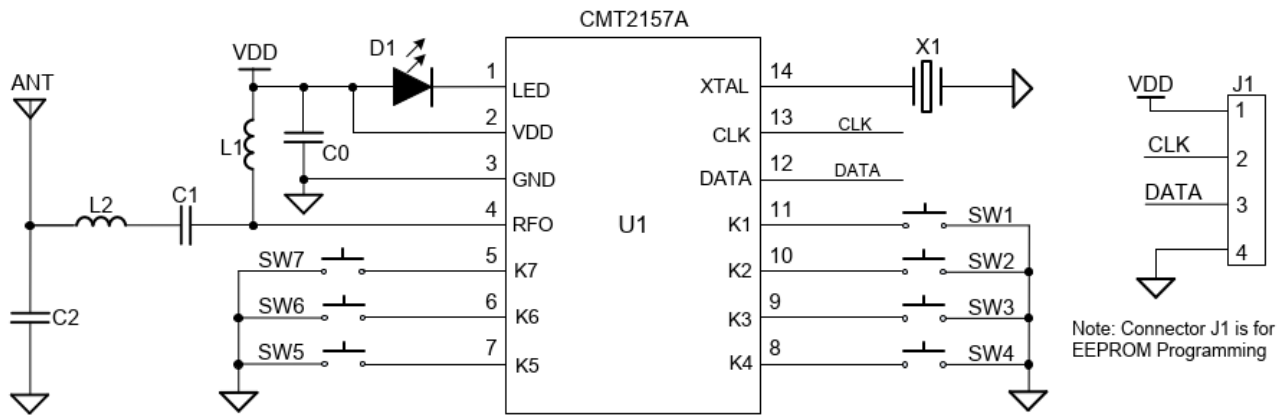

Figure 1. CMT2157A Typical Application Schematic

Table 1. BOM of 433.92/868.35 MHz Typical Application

Designator	Descriptions	Value		Unit	Manufacturer
		433.92 MHz	868.35 MHz		
U1	CMT2157A, 240 – 960 MHz (G)FSK/OOK stand-alone transmitter with encoder	-		-	CMOSTEK
X1	±20 ppm, SMD32*25 mm crystal	26		MHz	EPSON
C0	±20%, 0402 X7R, 25 V	0.1		uF	Murata GRM15
C1	±5%, 0402 NP0, 50 V	82	82	pF	Murata GRM15
C2	±5%, 0402 NP0, 50 V	9.1	3.9	pF	Murata GRM15
L1	±5%, 0603 multi-layer chip inductor	180	100	nH	Murata LQG18
L2	±5%, 0603 multi-layer chip inductor	22	5.1	nH	Murata LQG18
D1	D0603, red LED	-		-	-
SW[7:1]	Push buttons	-		-	-

Abbreviations

Abbreviations used in this data sheet are described below

AN	Application Notes	OBW	Occupied Bandwidth
BOM	Bill of Materials	OOK	On-Off Keying
BSC	Basic Spacing between Centers	PA	Power Amplifier
BW	Bandwidth	PC	Personal Computer
DC	Direct Current	PCB	Printed Circuit Board
EEPROM	Electrically Erasable Programmable Read-Only Memory	PLL	Phase Lock Loop
ESD	Electro-Static Discharge	PN	Phase Noise
ESR	Equivalent Series Resistance	RBW	Resolution Bandwidth
FSK	Frequency Shift Keying	RCLK	Reference Clock
GFSK	Gauss Frequency Shift Keying	RF	Radio Frequency
GUI	Graphical User Interface	RFPDK	RF Product Development Kit
IC	Integrated Circuit	RoHS	Restriction of Hazardous Substances
LDO	Low Drop-Out	Rx	Receiving, Receiver
Max	Maximum	SOT	Small-Outline Transistor
MCU	Microcontroller Unit	TBD	To Be Determined
Min	Minimum	Tx	Transmission, Transmitter
MOQ	Minimum Order Quantity	Typ	Typical
NPO	Negative-Positive-Zero	XO/XOSC	Crystal Oscillator
		XTAL	Crystal

Table of Contents

1.	Electrical Characteristics	5
1.1	Recommended Operating Conditions	5
1.2	Absolute Maximum Ratings	5
1.3	Transmitter Specifications	6
1.4	Crystal Oscillator	7
2.	Pin Descriptions	8
3.	Typical Performance Characteristics	9
4.	Typical Application Schematics	10
4.1	Low-Cost Application Schematic	10
4.2	FCC/ETSI Compliant Application Schematic	11
5.	Functional Descriptions	12
5.1	Overview	12
5.2	Modulation, Frequency, Deviation and Symbol Rate	12
5.3	Embedded EEPROM and RFPDK	13
5.4	Power Amplifier	15
5.5	PA Ramping	15
5.6	Working States	16
5.7	The Encoder	17
5.8	ID Study	20
5.9	Button Modes	21
5.10	LED Driving Capability	24
5.11	Low Battery Detection (LBD)	24
5.12	Crystal Oscillator and RCLK	24
6.	Ordering Information	26
7.	Package Outline	27
8.	Top Marking	28
8.1	CMT2157A Top Marking	28
9.	Other Documentations	29
10.	Revise History	30
11.	Contacts	31

1. Electrical Characteristics

$V_{DD} = 3.3\text{ V}$, $T_{OP} = 25\text{ }^{\circ}\text{C}$, $F_{RF} = 433.92\text{ MHz}$, output power is +10 dBm terminated in a matched $50\ \Omega$ impedance, unless otherwise noted.

1.1 Recommended Operating Conditions

Table 2. Recommended Operation Conditions

Parameter	Symbol	Conditions	Min	Typ	Max	Unit
Operation Voltage Supply	V_{DD}		1.8		3.6	V
Operation Temperature	T_{OP}		-40		85	$^{\circ}\text{C}$
Supply Voltage Slew Rate			1			mV/us

1.2 Absolute Maximum Ratings

Table 3. Absolute Maximum Ratings^[1]

Parameter	Symbol	Conditions	Min	Max	Unit
Supply Voltage	V_{DD}		-0.3	3.6	V
Interface Voltage	V_{IN}		-0.3	$V_{DD} + 0.3$	V
Junction Temperature	T_J		-40	125	$^{\circ}\text{C}$
Storage Temperature	T_{STG}		-50	150	$^{\circ}\text{C}$
Soldering Temperature	T_{SDR}	Lasts at least 30 seconds		255	$^{\circ}\text{C}$
ESD Rating		Human Body Model (HBM)	-2	2	kV
Latch-up Current		@ $85\text{ }^{\circ}\text{C}$	-100	100	mA

Note:

[1]. Stresses above those listed as "absolute maximum ratings" may cause permanent damage to the device. This is a stress rating only and functional operation of the device under these conditions is not implied. Exposure to maximum rating conditions for extended periods may affect device reliability.

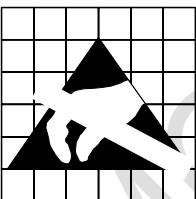

Caution! ESD sensitive device. Precaution should be used when handling the device in order to prevent permanent damage.

1.3 Transmitter Specifications

Table 4. Transmitter Specifications

Parameter	Symbol	Conditions	Min	Typ	Max	Unit
Frequency Range ^[1]	F_{RF}		240		960	MHz
Synthesizer Frequency Resolution	F_{RES}	$F_{RF} \leq 480$ MHz		198		Hz
		$F_{RF} > 480$ MHz		397		Hz
Symbol Rate	SR	FSK/GFSK	0.5		100	ksps
		OOK	0.5		40	ksps
(G)FSK Modulation Deviation Range	F_{DEV}		1		200	kHz
Bandwidth-Time Product	BT	GFSK modulation	-	0.5	-	-
Maximum Output Power	$P_{OUT(Max)}$			+13		dBm
Minimum Output Power	$P_{OUT(Min)}$			-10		dBm
Output Power Step Size	P_{STEP}			1		dB
PA Ramping Time ^[2]	t_{RAMP}		0		1024	us
Current Consumption ^[3] @ 433.92 MHz	$I_{DD-433.92}$	OOK, 0 dBm		6		mA
		OOK, +10 dBm		8.5		mA
		OOK, +13 dBm		10.2		mA
		FSK, 0 dBm		10.8		mA
		FSK, +10 dBm		23.8		mA
		FSK, +13 dBm		32		mA
Current Consumption ^[3] @ 868.35 MHz	$I_{DD-868.35}$	OOK, 0 dBm		6.1		mA
		OOK, +10 dBm		9.3		mA
		OOK, +13 dBm		11.2		mA
		FSK, 0 dBm		12.3		mA
		FSK, +10 dBm		26.7		mA
		FSK, +13 dBm		35.3		mA
Sleep Current	I_{SLEEP}			20		nA
Frequency Tune Time	t_{TUNE}			370		us
Phase Noise @ 433.92 MHz	$PN_{433.92}$	100 kHz offset from F_{RF}		-80		dBc/Hz
		600 kHz offset from F_{RF}		-96		dBc/Hz
		1.2 MHz offset from F_{RF}		-108		dBc/Hz
Phase Noise @ 868.35 MHz	$PN_{868.35}$	100 kHz offset from F_{RF}		-74		dBc/Hz
		600 kHz offset from F_{RF}		-90		dBc/Hz
		1.2 MHz offset from F_{RF}		-102		dBc/Hz
Harmonics Output for 433.92 MHz ^[4]	$H2_{433.92}$	2 nd harm @ 867.84 MHz, +13 dBm P_{OUT}		-52		dBm
	$H3_{433.92}$	3 rd harm @ 1301.76 MHz, +13 dBm P_{OUT}		-57		dBm
Harmonics Output for 868.35 MHz ^[4]	$H2_{868.35}$	2 nd harm @ 1736.7 MHz, +13 dBm P_{OUT}		-68		dBm
	$H3_{868.35}$	3 rd harm @ 2605.05 MHz, +13 dBm P_{OUT}		-52		dBm
OOK Extinction Ration				60		dB

Notes:

[1]. The frequency range is continuous over the specified range.

[2]. 0 and 2ⁿ us, n = 0 to 10, when set to "0", the PA output power will ramp to its configured value in the shortest possible time.

[3]. The working currents are tested with: 1527 packet format/Normal button mode/ 4 push buttons/Sync ID = 0/No LED.

[4]. The harmonics output is measured with the application shown as Figure 10.

1.4 Crystal Oscillator

Table 5. Crystal Oscillator Specifications

Parameter	Symbol	Conditions	Min	Typ	Max	Unit
Crystal Frequency ^[1]	F_{XTAL}		26	26	26	MHz
Crystal Tolerance ^[2]				±20		ppm
Load Capacitance ^[3]	C_{LOAD}		12		20	pF
Crystal ESR	R_m				60	Ω
XTAL Startup Time ^[4]	t_{XTAL}			400		us

Notes:

[1]. The CMT2157A can directly work with external 26 MHz reference clock input to XTAL pin (a coupling capacitor is required) with amplitude 0.3 to 0.7 Vpp.

[2]. This is the total tolerance including (1) initial tolerance, (2) crystal loading, (3) aging, and (4) temperature dependence. The acceptable crystal tolerance depends on RF frequency and channel spacing/bandwidth.

[3]. The required crystal load capacitance is integrated on-chip to minimize the number of external components.

[4]. This parameter is to a large degree crystal dependent.

2. Pin Descriptions

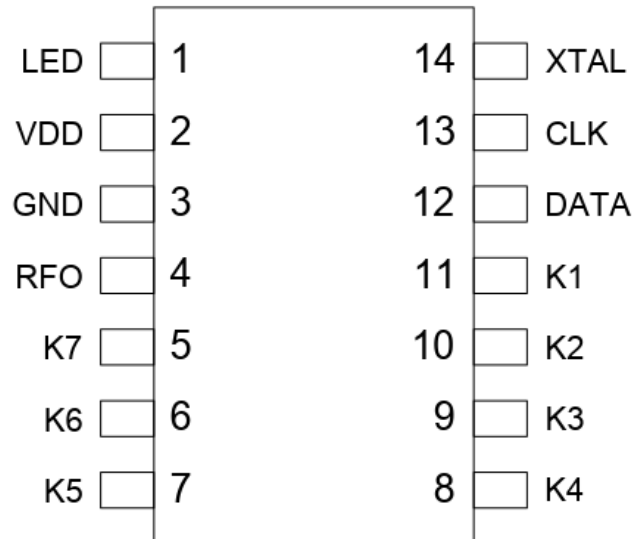

Figure 2. CMT2157A Pin Assignments

Table 6. CMT2157A Pin Descriptions

Pin Number	Name	I/O	Descriptions
1	LED	O	LED driver, active low
2	VDD	I	Power supply input
3	GND	I	Ground
4	RFO	O	Power amplifier output
5 - 11	K[7:1]	I	Push button 7 to 1
12	DATA	IO	Data pin to access the embedded EEPROM, internally pulled up to VDD
13	CLK	I	Clock pin to access the embedded EEPROM, internally pulled up to VDD
14	XTAL	I	26 MHz single-ended crystal oscillator input or External 26 MHz reference clock input

3. Typical Performance Characteristics

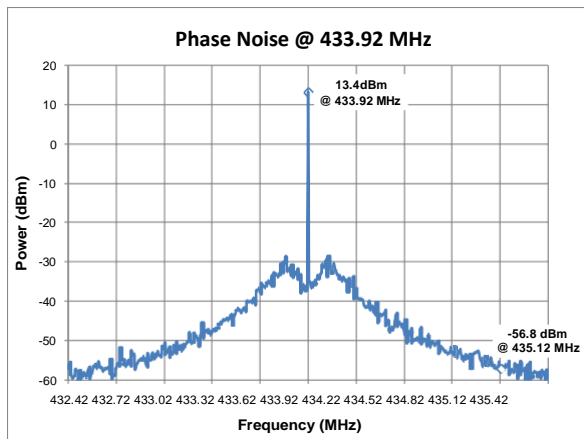

Figure 4. Phase Noise, $F_{RF} = 433.92$ MHz,
 $P_{OUT} = +13$ dBm, RBW = 10 kHz, Un-encoded

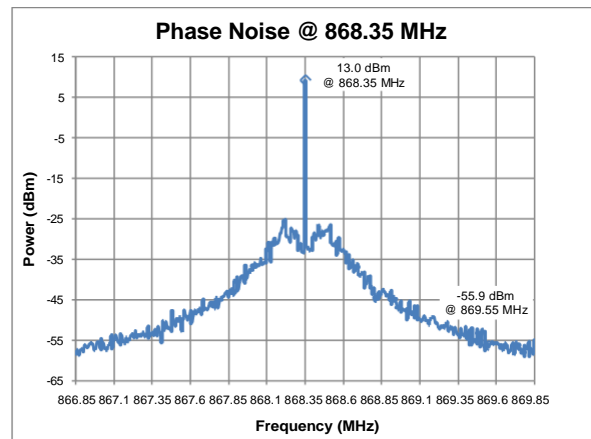

Figure 3. Phase Noise, $F_{RF} = 868.35$ MHz,
 $P_{OUT} = +13$ dBm, RBW = 10 kHz, Un-encoded

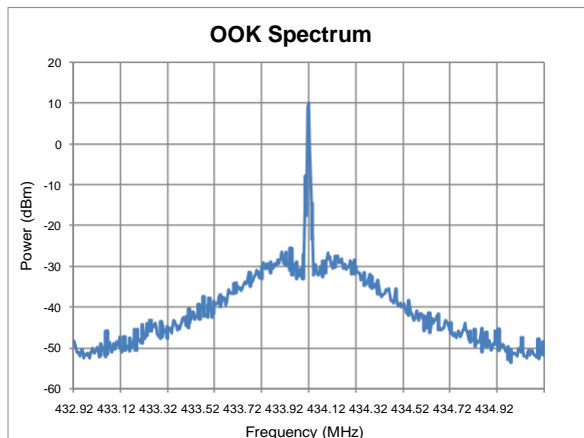

Figure 5. OOK Spectrum,
 $P_{OUT} = +10$ dBm, $t_{RAMP} = 32$ us

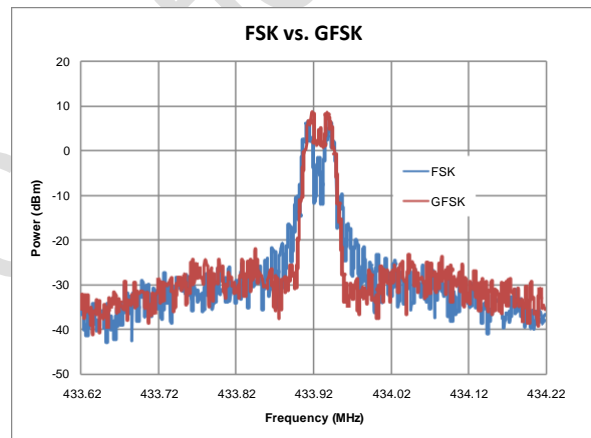

Figure 6. FSK/GFSK Spectrum,
 $SR = 9.6$ kbps, $F_{DEV} = 15$ kHz

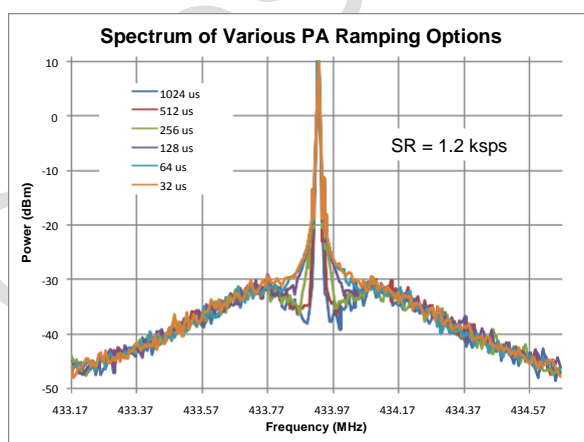

Figure 7. Spectrum of PA Ramping,
 $SR = 1.2$ kbps, $P_{OUT} = +10$ dBm

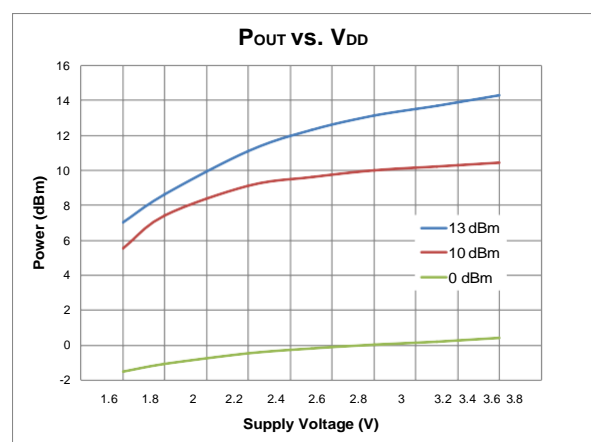

Figure 8. Output Power vs. Supply
Voltages, $F_{RF} = 433.92$ MHz

4. Typical Application Schematics

4.1 Low-Cost Application Schematic

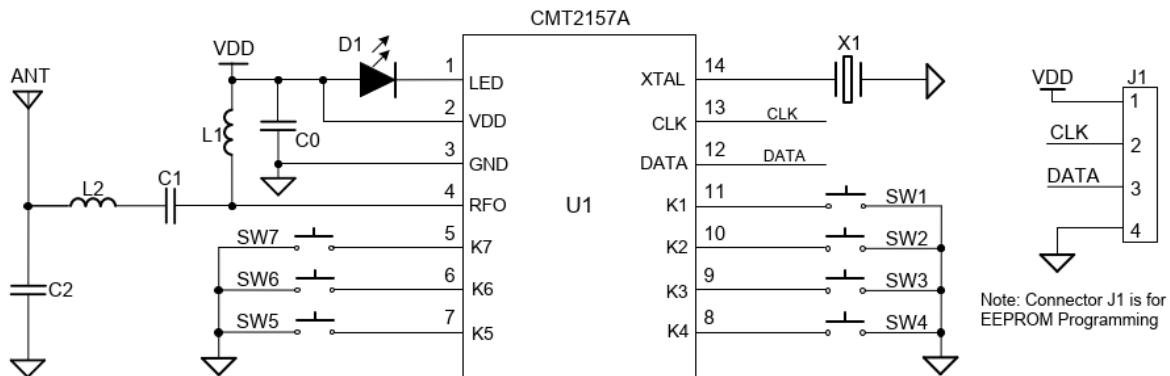

Figure 9. Low-Cost Application Schematic

Notes:

- Connector J1 is a must for the CMT2157A EEPROM access during development or manufacture phase.
- The general layout guidelines are listed below. For more design details, please refer to “AN100 CMT211x5x8x Transmitter Chip Schematic and PCB Layout Design Guide”.
 - Use as much continuous ground plane metallization as possible.
 - Use as many grounding vias (especially near to the GND pins) as possible to minimize series parasitic inductance between the ground pour and the GND pins.
 - Avoid using long and/or thin transmission lines to connect the components.
 - Avoid placing the nearby inductors in the same orientation to reduce the coupling between them.
 - Place C0 as close to the CMT2157A as possible for better filtering.
- The table below shows the BOM of 433.92/868.35 MHz Low-Cost Application. For the BOM of more applications, please refer to “AN100 CMT211x5x8x Transmitter Chip Schematic and PCB Layout Design Guide”.

Table 7. BOM of 433.92/868.35 MHz Low-Cost Application

Designator	Descriptions	Value		Unit	Manufacturer
		433.92 MHz	868.35 MHz		
U1	CMT2157A, 240 – 960 MHz (G)FSK/OOK stand-alone transmitter with encoder	-		-	CMOSTEK
X1	±20 ppm, SMD32*25 mm crystal	26		MHz	EPSON
C0	±20%, 0402 X7R, 25 V	0.1		uF	Murata GRM15
C1	±5%, 0402 NP0, 50 V	82	82	pF	Murata GRM15
C2	±5%, 0402 NP0, 50 V	9.1	3.9	pF	Murata GRM15
L1	±5%, 0603 multi-layer chip inductor	180	100	nH	Murata LQG18
L2	±5%, 0603 multi-layer chip inductor	22	5.1	nH	Murata LQG18
D1	D0603, red LED	-		-	-
SW[7:1]	Push buttons	-		-	-

4.2 FCC/ETSI Compliant Application Schematic

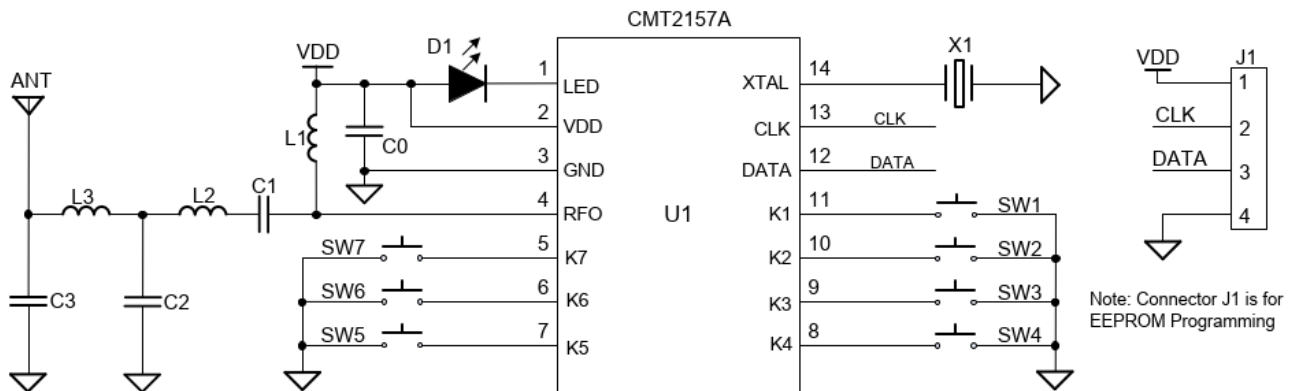

Figure 10. FCC/ETSI Compliant Application Schematic

Notes:

1. Connector J1 is a must for the CMT2157A EEPROM access during development or manufacture phase.
2. The general layout guidelines are listed below. For more design details, please refer to “AN100 CMT211x5x8x Transmitter Chip Schematic and PCB Layout Design Guide”.
 - Use as much continuous ground plane metallization as possible.
 - Use as many grounding vias (especially near to the GND pins) as possible to minimize series parasitic inductance between the ground pour and the GND pins.
 - Avoid using long and/or thin transmission lines to connect the components.
 - Avoid placing the nearby inductors in the same orientation to reduce the coupling between them.
 - Place C0 as close to the CMT2157A as possible for better filtering.
3. The table below shows the BOM of 433.92/868.35 MHz FCC/ETSI Compliant Application. For the BOM of more application, please refer to “AN100 CMT211x5x8x Transmitter Chip Schematic and PCB Layout Design Guide”.

Table 8. BOM of 433.92/868.35 MHz FCC/ETSI Compliant Application

Designator	Descriptions	Value		Unit	Manufacturer
		433.92 MHz	868.35 MHz		
U1	CMT2157A, 240 – 960 MHz (G)FSK/OOK stand-alone transmitter with encoder	-		-	CMOSTEK
X1	±20 ppm, SMD32*25 mm crystal	26		MHz	EPSON
C0	±20%, 0402 X7R, 25 V	0.1		uF	Murata GRM15
C1	±5%, 0402 NP0, 50 V	68	68	pF	Murata GRM15
C2	±5%, 0402 NP0, 50 V	15	10	pF	Murata GRM15
C3	±5%, 0402 NP0, 50 V	15	6.8	pF	Murata GRM15
L1	±5%, 0603 multi-layer chip inductor	180	100	nH	Murata LQG18
L2	±5%, 0603 multi-layer chip inductor	36	5.6	nH	Murata LQG18
L3	±5%, 0603 multi-layer chip inductor	18	6.8	nH	Murata LQG18
D1	D0603, red LED	-	-	-	
SW[7:0]	Push buttons	-	-	-	

5. Functional Descriptions

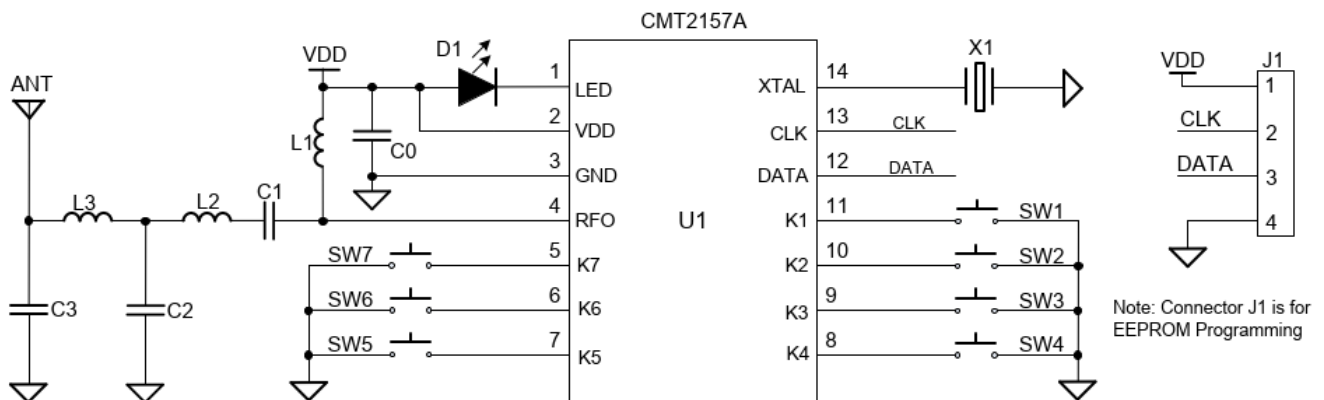

Figure 11. CMT2157A Functional Block Diagram

5.1 Overview

The CMT2157A is a true single-chip, highly flexible, high performance, OOK RF transmitter with embedded data encoder ideal for 240 to 960 MHz wireless applications. It is part of the CMOSTEK NextGenRF™ family, which includes a complete line of transmitters, receivers and transceivers. The device integrates a data encoder that is not only compatible with the most common used encoding format of 1527 and 2262, but also a more efficient, flexible and powerful format of 1920 designed by CMOSTEK. Up to 7 configurable push buttons are supported in multiple button modes. The device is optimized for the low system cost, low power consumption, battery powered application with its highly integrated and low power design.

The functional block diagram of the CMT2157A is shown in figure above. The CMT2157A is based on direct synthesis of the RF frequency by means of a fully integrated low-noise fractional-N frequency synthesizer. It uses a 1-pin crystal oscillator circuit with the required crystal load capacitance integrated on-chip to minimize the number of external components. Every analog block is calibrated on each Power-on Reset (POR) to an internal reference voltage source. The calibration can help the chip to finely work under different temperatures and supply voltages. The transmission is triggered by pressing the push button(s). The data is modulated and sent out by a highly efficient PA which output power can be configured from -10 to +13 dBm in 1 dB step size. RF Frequency, PA output power and other product features can be programmed into the embedded EEPROM by the RFPDK and USB Programmer. This saves the cost and simplifies the product development and manufacturing effort. Alternatively, in stock product of 868.35 MHz is available for immediate demands with no need of EEPROM programming. The CMT2157A operates from 1.8 to 3.6 V so that it can finely work with most batteries to their useful power limits. It only consumes 26.7 mA when transmitting +10 dBm FSK signal at 868.35 MHz under 3.3 V supply voltage.

5.2 Modulation, Frequency, Deviation and Symbol Rate

The CMT2157A supports GFSK/FSK modulation with the symbol rate up to 100 kbps, as well as OOK modulation with the symbol rate up to 40 kbps. The supported deviation of the (G)FSK modulation ranges from 1 to 200 kHz. It continuously covers the frequency range from 240 to 960 MHz, including the license free ISM frequency band around 315 MHz, 433.92 MHz, 868.35 MHz and 915 MHz. The device contains a high spectrum purity low power fractional-N frequency synthesizer with output frequency resolution better than 198 Hz when the frequency is less than 480 MHz, and is about 397 Hz when the frequency is larger than 480 MHz. See Table 9 for the modulation, frequency, deviation and symbol rate specifications.

Table 9. Modulation, Frequency, Deviation and Symbol Rate

Parameter	Value	Unit
Modulation	(G)FSK/OOK	-
Frequency	240 to 960	MHz
Deviation	1 to 200	kHz
Frequency Resolution ($F_{RF} \leq 480$ MHz)	198	Hz
Frequency Resolution ($F_{RF} > 480$ MHz)	397	Hz
Symbol Rate (FSK/GFSK)	0.5 to 100	ksp/s
Symbol Rate (OOK)	0.5 to 40	ksp/s

5.3 Embedded EEPROM and RFPDK

The RFPDK (RF Products Development Kit) is a very user-friendly software tool delivered for the user configuring the CMT2157A in the most intuitive way. The user only needs to fill in/select the proper value of each parameter and click the “Burn” button to complete the chip configuration. No register access and control is required in the application program. See figure below for the accessing of the EEPROM and Table 10 for the summary of all the configurable parameters of the CMT2157A on the RFPDK.

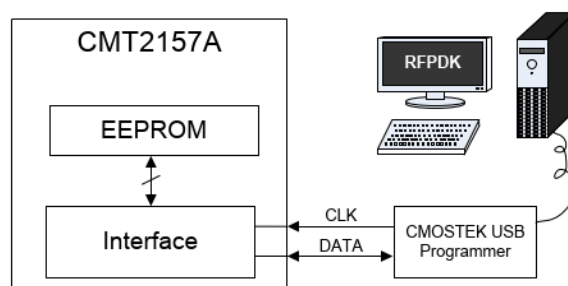
**Figure 12. Accessing Embedded EEPROM**

For more details of the CMOSTEK USB Programmer and the RFPDK, please refer to “AN113 CMT2150A/2250(1)A One-Way RF Link Development Kits User’s Guide”.

Table 10. Configurable Parameters in RFPDK

Category	Parameters	Descriptions	Default	Mode
RF Settings	Frequency	To input a desired transmitting radio frequency in the range from 240 to 960 MHz. The step size is 0.001 MHz.	868.35 MHz	Basic Advanced
	Modulation	The option is FSK or GFSK and OOK.	FSK	Basic Advanced
	Tx Power	To select a proper transmitting output power from -10 dBm to +14 dBm, 1 dBm margin is given above +13 dBm.	+13 dBm	Basic Advanced
	Xtal Cload	On-chip XOSC load capacitance options: from 10 to 22 pF.	15.00 pF	Basic Advanced
	Symbol Rate	To determines the symbol rate of the transmitted data: from 0.5 to 100 ksp/s in (G)FSK mode and 0.5 to 40 ksp/s in OOK mode.	2.4	Basic Advanced

Category	Parameters	Descriptions	Default	Mode
	Deviation	The FSK frequency deviation. The range is from 1 to 200 kHz.	35 kHz	Basic Advanced
	PA Ramping	To control PA output power ramp up/down time, options are 0 and 2 ⁿ us (n from 0 to 10).	0 us	Advanced
	LED Driving Capability	This defines the driving current of the LED pin. The options are: Disable, 5, 10, 15 or 20 mA.	5 mA	Advanced
	LBD Threshold	This defines the Low Battery Detection threshold. The options are: Disable, 1.7, 1.8, 1.9, 2.0, 2.1, 2.2, 2.3, 2.4, 2.5, 2.6, 2.7 or 2.8 V.	2.4 V	Advanced
	Data Representation	To select whether the frequency "Fo + Fdev" represent data 0 or 1. The options are: 0: F-high 1: F-low, or 0: F-low 1: F-high.	0: F-low 1: F-high	Advanced
Encoder Settings	Encoder	Select the packet encoding format, the options are: 1920, 1527 and 2262. See Table 13, Table 14 and Table 15 for the configurable parameters in each packet.	1527	Basic Advanced
	Bit Format	This tells the device how many symbols are used to construct a single bit in the 1920 mode. The options are: 3, 4, 5 or 6 sym/bit. The Bit Format is fixed at 4 sym/bit in 1527 mode and 8 sym/bit in 2262 mode. It is only available in 1920 mode.	3	Basic Advanced
	Number of Packets	This defines the minimum number of packet(s) being transmitted during each button pressing action. It also defines the number of packet(s) being transmitted during each periodic transmission. The range is from 1 to 256.	1	Advanced
	Packet Interval	This defines the time interval amount two consecutive transmitted packets. The unit is in symbol, the range is from 0 to 255 symbols of zero.	0 symbols of zero	Basic Advanced
Push Button Settings	Button Mode	Select the button encoding mode, the options are: Normal, Matrix, Toggle and PWM. For 1920 and 1527 format, all these button modes are supported; For 2262 format, only Normal button mode is supported.	Normal	Basic Advanced
	On/Off Button(s)	Select the numbers of on/off button for Toggle and PWM button modes, the options are: Single or Separated.	Single	Basic Advanced
	Number of Button(s)	This option is only available in Normal Button Mode, and Encoder is set to 1920 and 1527. It defines the number of activated button(s) to be used in the application. The range is from 1 to 7.	4	Basic Advanced
	Data Inversion	Allow the user to select whether or not to inverse the transmitted data bits values in the Normal and Toggle Button Mode. The options are: No or Yes.	No	Advanced
	Periodic Transmission	Turn on/off the periodic transmission mode of the device. The options are: On or Off.	Off	Advanced

Category	Parameters	Descriptions	Default	Mode
	Periodic Time	This parameter is only available when Periodic Transmission is turned on. It defines the periodic time for transmitting a fixed set of data. The range is from 2 to 7683.512 s, accurate to 3 decimal points. It is only available when Periodic Transmission is on.	1.000 s	Advanced
Study Settings	ID Study	Turn on/off the Sync ID study function, the options are: On or Off. The ID Study is only supported in 1920 and 1527 mode.	Off	Advanced
	Study Trigger Time	This parameter is only available when ID Study is turned on. It defines the time from the instance of pressing the study button to the instance at which the device starts to transmit the study packets. The range is from 1 to 15 second(s).	5 s	Advanced
	Study Button	This parameter is only available when ID Study is turned on. It defines which button is used to trigger the transmission of the study packets. The options are the current buttons used in the Push Button Settings.	Pin 11 (K1)	Advanced
	Study Power	This parameter is only available when ID Study is turned on. It defines the PA power when the device is transmitting the study packets. The range is from -10 to +14 dBm.	-6 dBm	Basic Advanced

5.4 Power Amplifier

A highly efficient single-ended Power Amplifier (PA) is integrated in the CMT2157A to transmit the modulated signal out. Depending on the application, the user can design a matching network for the PA to exhibit optimum efficiency at the desired output power for a wide range of antennas, such as loop or monopole antenna. Typical application schematics and the required BOM are shown in “Chapter 4 Typical Application Schematic”. For the schematic, layout guideline and the other detailed information please refer to “AN100 CMT211x5x8x Transmitter Chip Schematic and PCB Layout Design Guide”.

The output power of the PA can be configured by the user within the range from -10 dBm to +13 dBm in 1 dB step size using the CMOSTEK USB Programmer and RFPDK.

5.5 PA Ramping

When the PA is switched on or off quickly, its changing input impedance momentarily disturbs the VCO output frequency. This phenomenon is called VCO pulling, and it manifests as spectral splatter or spurs in the output spectrum around the desired carrier frequency. By gradually ramping the PA on and off, PA transient spurs are minimized. The CMT2157A has built-in PA ramping configurability with options of 0, 1, 2, 4, 8, 16, 32, 64, 128, 256, 512 and 1024 us, as shown in Figure 13. When the option is set to “0”, the PA output power will ramp up to its configured value in the shortest possible time. The ramp down time is identical to the ramp up time in the same configuration.

CMOSTEK recommends that the maximum symbol rate should be no higher than 1/2 of the PA ramping “rate”, as shown in the formula below:

$$SR_{Max} \leq 0.5 * \left(\frac{1}{t_{RAMP}} \right)$$

In which the PA ramping “rate” is given by $(1/t_{\text{RAMP}})$. In other words, by knowing the maximum symbol rate in the application, the PA ramping time can be calculated by:

$$t_{\text{RAMP}} \leq 0.5 * \left(\frac{1}{\text{SR}_{\text{MAX}}} \right)$$

The user can select one of the values of the t_{RAMP} in the available options that meet the above requirement. If somehow the t_{RAMP} is set to be longer than “ $0.5 * (1/\text{SR}_{\text{MAX}})$ ”, it will possibly bring additional challenges to the OOK demodulation of the Rx device.

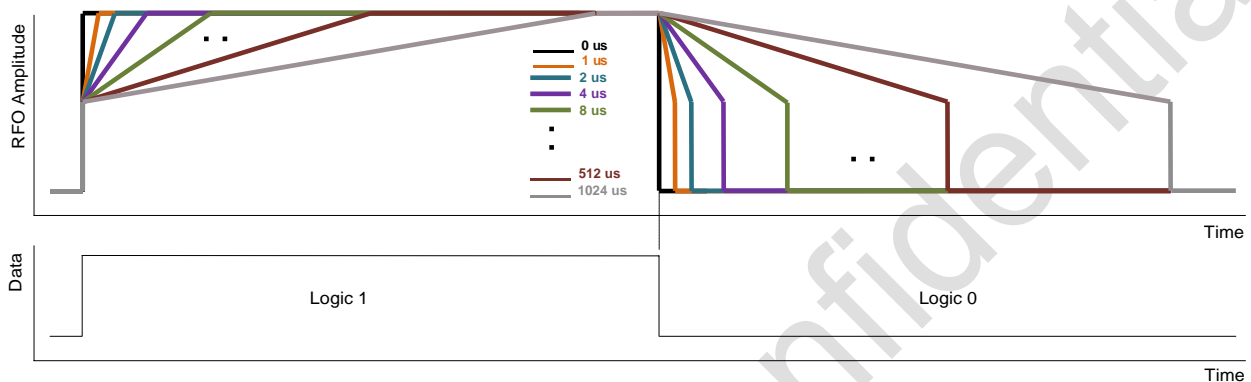

Figure 13. PA Ramping Time

5.6 Working States

The CMT2157A has following 4 different working states: SLEEP, XO-STARTUP, TUNE and TRANSMIT. The device stays in the SLEEP state when no transmission is performed. Once the button(s) is/are pressed, the device goes through the sequence of SLEEP → XO-STARTUP → TUNE → TRANSMIT to transmit the data. After the transmission the device goes back to the SLEEP state. When the device works in the periodic transmission mode, the device periodically wakes up from the SLEEP state, goes the same sequence, performs the transmission and goes back to the SLEEP state.

SLEEP

When the CMT2157A is in the SLEEP state, all the internal blocks are turned off and the current consumption is minimized to 20 nA typically.

XO-STARTUP

Once the CMT2157A received the valid control signal, it will go into the XO-STARTUP state, and the internal XO starts to work. The user has to wait for the t_{XTAL} to allow the XO to get stable. The t_{XTAL} is to a large degree crystal dependent. A typical value of t_{XTAL} is provided in the Table 11.

TUNE

The frequency synthesizer will tune the CMT2157A to the desired frequency in the time t_{TUNE} . The PA can be turned on to transmit the data generated by the embedded encoder only after the TUNE state is done.

TRANSMIT

The CMT2157A starts to modulate and transmit the data. The data packets being transmitted are generated by the embedded encoder, and they are determined by the encoder selected, the button mode and the button being pressed.

Table 11. Main Timing Spec in Different Working States

Parameter	Symbol	Min	Typ	Max	Unit
XTAL Startup Time ^[1]	t_{XTAL}		400		us
Time to Tune to Desired Frequency ^[2]	t_{TUNE}		370		us

Notes:
 [1]. This parameter is to a large degree crystal dependent.
 [2]. From XO stable to ready to transmit.

5.7 The Encoder

The device supports 3 types of encoding formats: 1920, 1527 and 2262. The packets of these 3 modes have different structures which will be introduced in the below sub-sections. The table below summarizes the major features of the 3 encoding formats.

Table 12. Feature Summary of the 3 Encoding Formats

Format	Bit Format (sym/bit)	Sync ID Length (bits)	Data Length (bits)	CRC	ID Study	Button Modes ^[1]
1920	3/4/5/6	1 – 32	1 – 7	Support	Support	All
1527	4	20	1 – 7	NA	Support	All
2262	8	6 – 11	1 – 6	NA	Not Support	Normal Mode

Note:
 [1]. Button Modes include Normal Mode, Matrix Mode, Toggle Mode and PWM Mode.

The following sections only give the abstracts of these formats. In the below explanations, some elements in the packet are measured in the unit of “symbol”, while some of them are measured in the unit of “bit”. For those which have the unit of “bit”, one “bit” is constructed (encoded) by several “symbols”. In the figures, “SYM” represents the word “symbol”.

5.7.1 1920 Packet Structure

Two types of packet structures are supported for 1920 format: Normal Packet and Study Packet. The following configurable parameters are shared by the two structures.

Table 13. Configurable Parameters in 1920 Packet

Parameter	Descriptions	Default	Mode
Preamble	The size of the valid preamble, the options are: None or 16-symbol.	None	Basic Advanced
Address (Sync ID) Length	The range of the Sync ID Length is from 1 to 32 bits.	32-bit	Basic Advanced
Address (Sync ID) Value	The value of the Sync ID has the range from 0 to $2^{\text{Length}-1}$.	0	Basic Advanced

Normal Packet

The normal packet is used to control the data pins of the CMOSTEK receiver CMT2250A or PWM output of the CMT2251A. It contains a 16-symbol Preamble, a 32-symbol Head_N (which indicates that the current packet is a normal packet rather than a study packet), a Sync ID, a Configurable Data Field and an 8-symbol CRC.

Preamble 16 symbols	Head_N 32 symbols	Address (Sync ID) configurable 1-32 bits	D0 1 bit	D1 1 bit	D2 1 bit	D3 1 bit	CRC 8 symbols
------------------------	----------------------	---	-------------	-------------	-------------	-------------	------------------

Figure 14. 1920 Normal Packet Structure

Study Packet

The study packet is used for the receiver to learn the Sync ID from the CMT2157A in order to pair the two devices. It contains an optional Preamble, a 32-symbol Head_S, a Sync ID and an 8-symbol CRC.

Preamble (Optional) 16-symbol	Head_S 32-symbol	Address (Sync ID) configurable 1-32 bits	CRC 8-symbol
----------------------------------	---------------------	---	-----------------

Figure 15. 1920 Study Packet Structure

Bit Format

In 1920 packet, a single bit can be constructed (encoded) by 3, 4, 5 or 6 symbols. The user can select the desired value of the “Bit Format” parameter on the RFPDK. Please note that only the Sync ID field and the D0, D1, D2, D3, D4, D5, D6 have the unit of “bit”.

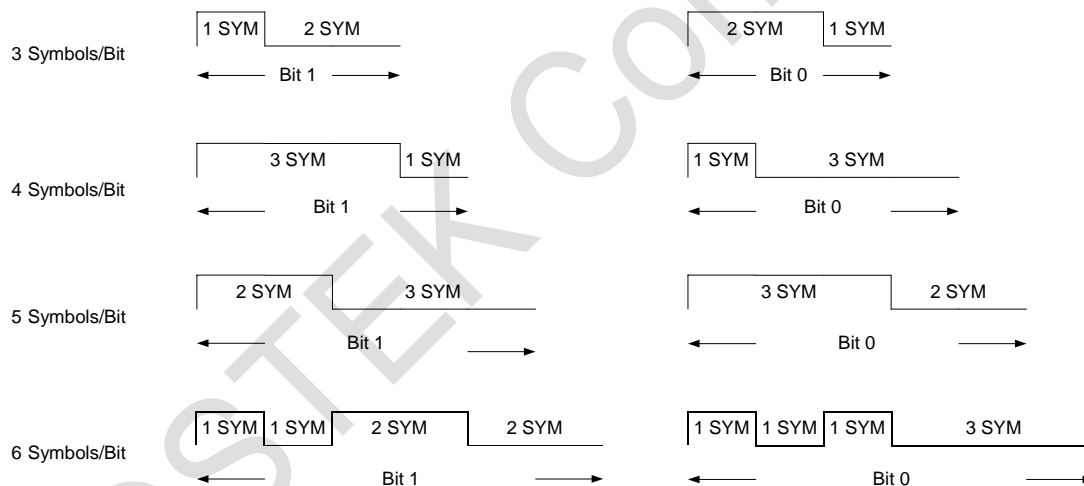

Figure 16. 1920 Bit Format Options

5.7.2 1527 Packet Structure

Two types of packet structures are supported for 1527 format: Normal Packet and Study Packet. The following configurable parameter is shared by the two structures.

Table 14. Configurable Parameters in 1527 Packet

Parameter	Descriptions	Default	Mode
Address (Sync ID) Value	The range of the Sync ID value is from 0 to $2^{20}-1$. This is because the Sync ID Length is fixed at 20 for 1527.	0	Basic Advanced

In the traditional 1527 format, 8 OSC clocks are equal to 1 LCK, 4 LCK are equal to 1 symbol. By using the CMT2250A pairing with CMT2157A, the user does not need to adjust the OSC to determine the symbol rate, because the symbol rate is directly programmed. The Bit Format is fixed at 4 symbols (16 LCK) per bit.

Normal Packet

The traditional 1527 packet contains a 32-symbol Sync, a 20-bit Address (Sync ID) and 4-bit Data. CMOSTEK has defined a 1527 Study Packet to support the ID study in 1527 mode. The traditional packet introduced here is called the “Normal Packet”.

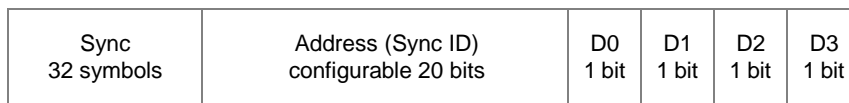

Figure 17. 1527 Normal Packet Structure

Study Packet

The 1527 Study packet contains a 32-symbol Head_S and a 20-bit Address (Sync ID), as shown below.

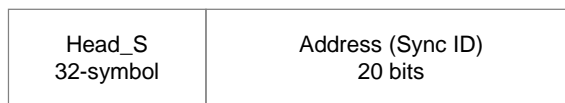

Figure 18. 1527 Study Packet Structure

Bit Format

In 1527 packet, a single bit is constructed by 4 symbols, as shown below. The user can select the desired value of the “Bit Format” parameter on the RFPDK. Please note that only the Sync ID field and the D0, D1, D2, D3, D4, D5, D6 field have the unit of “bit”.



Figure 19. 1527 Bit Format Options

5.7.3 2262 Packet Structure

ID Study is not supported in 2262 mode. Only one packet structure is supported.

Table 15. Configurable Parameters in 2262 Packet

Parameter	Descriptions	Default	Mode
Address (Sync ID) Length	This is the range of the Sync ID Length. The range is from 6 to 11 bits. This parameter also defines the number of data bits, because the total number of Sync ID and Data bits is fixed at 12.	8-bit	Basic Advanced
Address (Sync ID) Value	The value of each bit of the Sync ID can only be represented by 0, 1 or f.	00000000	Basic Advanced

In the traditional 2262 format, 4 OSC clocks (1 OSC clock cycle is notated as 1 α) are equal to 1 symbol. By using the CMOSTEK products, the user does not need to adjust the OSC to define the symbol rate, because the symbol rate is directly programmed. The Bit Format is fixed at 8 symbols per bit.

Normal Packet

The traditional 2262 packet contains an Address (Sync ID), a Data, and a 32-symbol Sync.



Figure 20. 2262 Packet Structure

Bit Format

In 2262 packet, a single bit is constructed by 8 symbols, as shown below. Please note that only the Address (Sync ID) field and the Data field have the unit of “bit”. In the below diagram, 1 OSC clock cycle is notated as 1 α referring to the original 2262 timing descriptions.

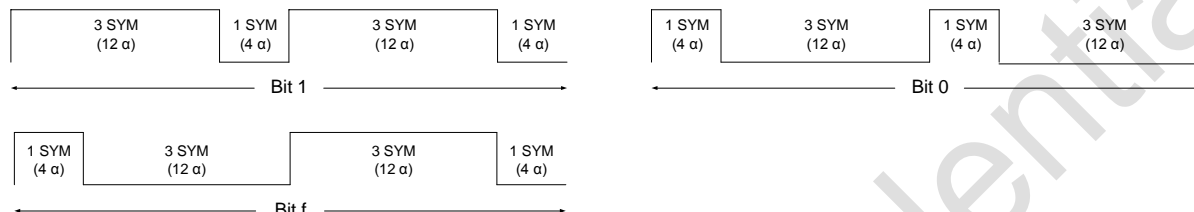

Figure 21. 2262 Bit Format Options

5.8 ID Study

The ID Study function, which is supported in 1920 and 1527 modes, allows the receiver to study the Sync ID sent by the CMT2157A. Since then, the receivers Sync ID is identical to that of the CMT2157A and therefore two devices are paired. The lengths of the Sync ID are different in the different packet formats. In 1920 format, it is from 1 to 32 bits. In 1527 format, it is fixed at 20 bits.

The ID Study is initialized by the CMT2157A. It is done by executing the following steps. An example of CMT2157A pairing with CMT2250/51A is given below.

1. Press the Study Button on the CMT2157A and hold it over the time defined by the “Study Trigger Time”.
2. CMT2157A starts to transmit the Study Packets, wait 1-2 seconds then release the Study Button.
3. Try to press a certain button on the CMT2157A to check if the CMT2250/51A react correctly.

The figure below shows the timing characteristic after pressing down a study button. The Study Power is always independently configure from the TX Power. In this example, the Study Power is set smaller than the TX Power.

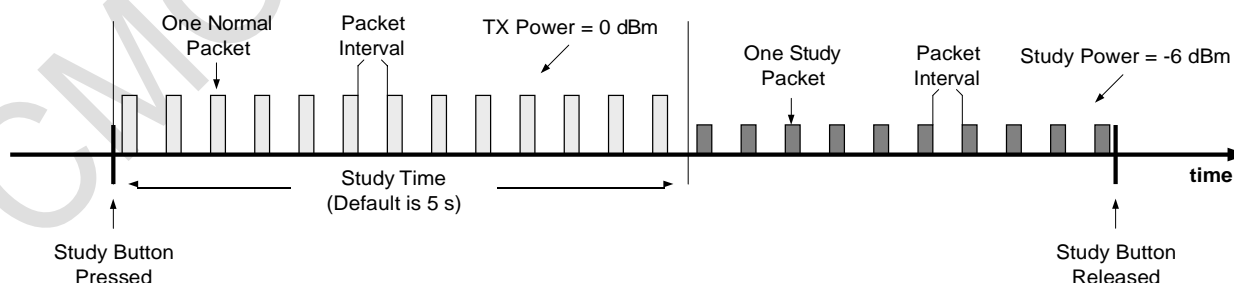

Figure 22. Timing of Study Button Pressing Event

5.9 Button Modes

The button modes define the functions of the input pins K1 – K7. The CMT2157A supports 4 different button modes: Normal, Matrix, Toggle and PWM, which are configured on the RFPDK. The following sections give the abstract of each button mode.

5.9.1 Normal

The Normal Button Mode is supported in 1920, 1527 and 2262 format. In this mode, the buttons are directly mapped to the data field of the packet. Multiple buttons can be pressed at the same time. For 1920 and 1527, the largest number of buttons is 7 which are defined by the parameter “Number of Button(s)”. For 2262, the largest number of buttons is 6, which is determined by the Sync ID Length. The figure below gives an example which 4 push button keys are selected.

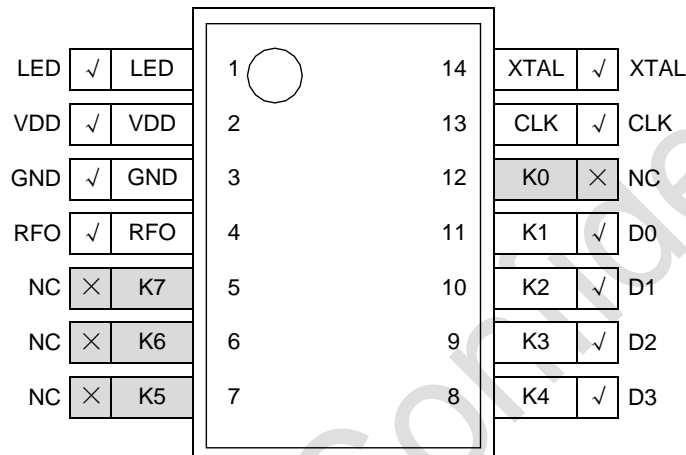

Figure 23. Normal Button Mode

In normal button mode, the number of button(s) is used to determine the number of data bits in a packet. The table below shows when 4 buttons are used and the pins K1 – K4 are mapped to the data D0 – D3, “1” in the Push Buttons section means the corresponding button(s) is/are pressed, while the “1” in the Data Bits section means logic “1” to be transmitted.

Table 16. Mapping from K1-K4 to D0-D3 in Normal Button Mode

Push Buttons				The Data Bits			
K1	K2	K3	K4	D0	D1	D2	D3
1	0	0	0	1	0	0	0
0	1	0	0	0	1	0	0
1	1	0	0	1	1	0	0
0	0	1	0	0	0	1	0
1	0	1	0	1	0	1	0
0	1	1	0	0	1	1	0
1	1	1	0	1	1	1	0
0	0	0	1	0	0	0	1
1	0	0	1	1	0	0	1
0	1	0	1	0	1	0	1
1	1	0	1	1	1	0	1
0	0	1	1	0	0	1	1
1	0	1	1	1	0	1	1
0	1	1	1	0	1	1	1
1	1	1	1	1	1	1	1

5.9.2 Matrix

The Matrix Button Mode is supported in 1920 and 1527 format. In the Matrix Button Mode, the number of buttons is fixed at 5. On the RFPDK, it can be seen that the 5 buttons are assigned to pin 11 (K1) – pin 7 (K5). In this mode, at most two buttons can be pressed at the same time. The figure below gives an example of Matrix mode push button arrangement.

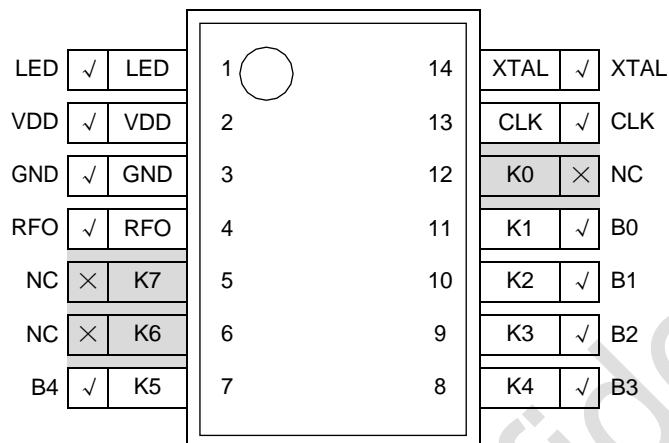

Figure 24. Matrix Button Mode

The user is able to use the 5 buttons K1(B0) – K5(B4) to generate different combinations of the data D0 – D3 to be transmitted. The number of data bits to be transmitted is fixed at 4. The table below shows the matrix. For the K1 – K5 buttons, “1” in the Push Buttons section means the corresponding button(s) is/are pressed down, while the “1” in the Data Bits section means a logic “1” to be transmitted..

Table 17. Mapping from K1-K5 to D0-D3 in Matrix Button Mode

Push Buttons					The Data Bits			
K1	K2	K3	K4	K5	D0	D1	D2	D3
1	0	0	0	0	1	0	0	0
0	1	0	0	0	0	1	0	0
0	0	1	0	0	1	1	0	0
0	0	0	1	0	0	0	1	0
0	0	0	0	1	1	0	1	0
1	1	0	0	0	0	1	1	0
1	0	1	0	0	1	1	1	0
1	0	0	1	0	0	0	0	1
1	0	0	0	1	1	0	0	1
0	1	1	0	0	0	1	0	1
0	1	0	1	0	1	1	0	1
0	1	0	0	1	0	0	1	1
0	0	1	1	0	1	0	1	1
0	0	1	0	1	0	1	1	1
0	0	0	1	1	1	1	1	1

5.9.3 Toggle

The Toggle Button Mode is supported in 1920 and 1527. In this mode, 5 or 6 buttons are used. Four buttons directly mapped to the data D0 – D3 are used to control the data. Besides, a single button or two separated buttons used to turn on/off the data can be chosen by the parameter “On/Off Button(s)”. In this mode, only one button can be pressed at the same time. Pin 12 (K0) and Pin 5 (K7) are never used in this mode. The figure below gives examples of the pin functions in Toggle mode.

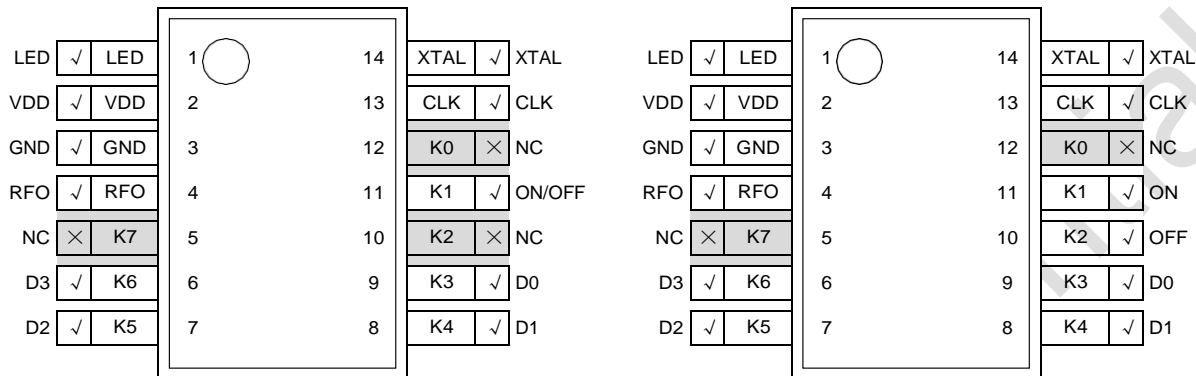

Figure 25. Toggle Button Mode with Single (left) and Separated (right) ON/OFF Button(s)

For the 4 data buttons mapped to D0 – D3, every time a button is pressed, the generated data bit toggles. For example, if the default value of D1 is 0, press K4 down, the D1 is set to 1 in the current transmission, release the K4 and press it down again, the D1 is set to 0 in the current transmission, and so on. This is what it means by “Toggle”. See the table below for the examples of toggle button mode

Table 18. Examples of the Toggle Button Mode

On/Off Button(s)	Pressed Button (Times)	D0	D1	D2	D3
Single (K1 is On/Off)	Press K4 (D1) – 1 st Time	0	1	0	0
	Press K4 (D1) – 2 nd Time	0	0	0	0
	Press K4 (D1) – 3 rd Time	0	1	0	0
	Press K1 – 1 st Time (On)	1	1	1	1
	Press K1 – 2 nd Time (Off)	0	0	0	0
	Press K1 – 3 rd Time (On)	1	1	1	1
Separated (K1 is On K2 is Off)	Press K4 (D1) – 1 st Time	0	1	0	0
	Press K4 (D1) – 2 nd Time	0	0	0	0
	Press K4 (D1) – 3 rd Time	0	1	0	0
	Press K1 (On)	1	1	1	1
	Press K2 (Off)	0	0	0	0
	Press K1 (On)	1	1	1	1

5.9.4 PWM

The PWM Button Mode is only supported for 1920 and 1527 encoding format. In this mode, 2 buttons are used to send out commands to increase or decrease the duty ratio of the PWM output of the CMT2251A. A single on/off button, or two separated on/off buttons can be chosen by the parameter “On/Off Button(s)”. The “On” command sets the PWM output of the CMT2251A to 100% of duty ratio, while the “Off” command sets the PWM output to 0% of duty ratio. In this mode, only one button can be pressed at the same time. Pin 12 (K0), Pin 9 (K3), Pin 6 (K6) and Pin 5 (K7) are never used in this mode. The commands of On, Off, Increase and Decrease are represented by D0 – D3. The figure below gives examples of the pin

functions in PWM mode.

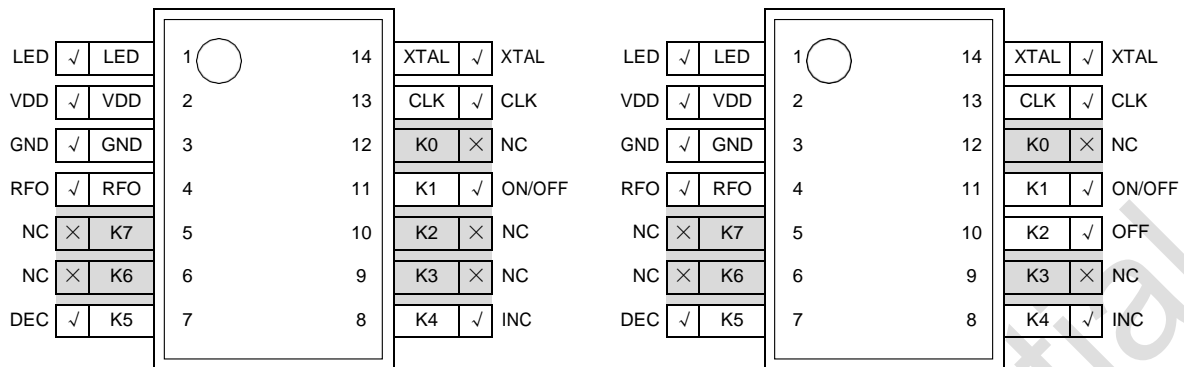

Figure 26. PWM Button Mode with Single (left) and Separated (right) ON/OFF Button(s)

If K1 is used as the On/Off Button, press it down once, the “On” command is transmitted, release and press it down again, the “Off” command is transmitted, and so on. In this case, K1 is a “Toggle” button. If the K1 is used as the On Button and K2 is used as the Off Button, pressing K1, the “On” command is transmitted; pressing K2, the “Off” command is transmitted.

5.10 LED Driving Capability

This defines the maximum current driving capacity on the LED pin. Once the LED pin is enabled, it will light up or flash to indicate two events:

- When the chip is transmitting data, the LED will light up until the transmission is finished to notify the user the chip is working, when the LBD is disabled, or LBD is enabled but there is no low battery detected.
- When the LBD is enabled and there is valid low battery detection on the button(s) pressing, the LED will flash at least 5 times at the frequency of 6 Hz to notify the user the battery is running out.

5.11 Low Battery Detection (LBD)

This defines the Low Battery Detection threshold. Once the LBD is enabled, the chip will automatically check the battery status before each transmission. Once the chip finds that the battery output is less than the detection threshold, the LED will flash at least 5 times at the frequency of 6 Hz to notify the user. Once the LED flashes, the performance of the transmission is not guaranteed. The user should change the batteries to new ones.

5.12 Crystal Oscillator and RCLK

The CMT2157A uses a 1-pin crystal oscillator circuit with the required crystal load capacitance integrated on-chip. Figure 27 shows the configuration of the XTAL circuitry and the crystal model. The recommended specification for the crystal is 26 MHz with ± 20 ppm, ESR (R_m) < 60 Ω , load capacitance C_{LOAD} ranging from 12 to 20 pF. To save the external load capacitors, a set of variable load capacitors C_L is built inside the CMT2157A to support the oscillation of the crystal.

The value of load capacitors is configurable with the CMOSTEK USB Programmer and RFPDK. To achieve the best performance, the user only needs to input the desired value of the XTAL load capacitance C_{LOAD} of the crystal (can be found in the datasheet of the crystal) to the RFPDK, then finely tune the required XO load capacitance according to the actual XO frequency. Please refer to “AN113 CMT2157A/2250(1)A One-Way RF Link Development Kits User’s Guide” for the method of choosing the right value of C_L .

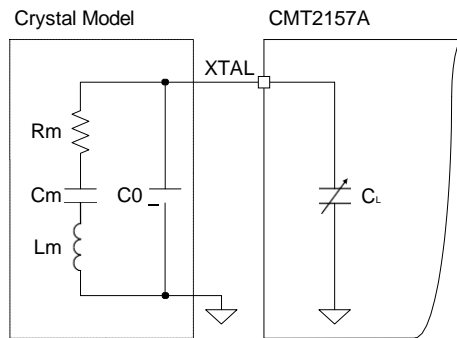
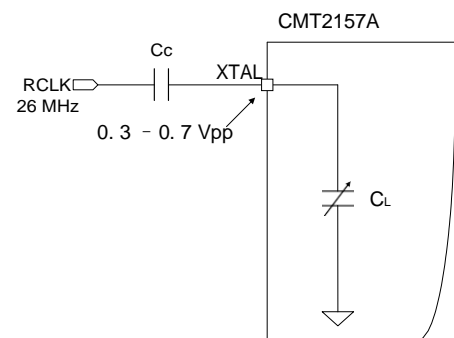
**Figure 27. XTAL Circuitry and Crystal Model****Figure 28. RCLK Circuitry**

If a 26 MHz RCLK (reference clock) is available in the system, the user can directly use it to drive the CMT2157A by feeding the clock into the chip via the XTAL pin. This further saves the system cost due to the removal of the crystal. A coupling capacitor is required if the RCLK is used. The recommended amplitude of the RCLK is 0.3 to 0.7 Vpp on the XTAL pin. Also, the user should set the internal load capacitor C_L to its minimum value. See Figure 28 for the RCLK circuitry.

6. Ordering Information

Table 19. CMT2157A Ordering Information

Part Number	Descriptions	Package Type	Package Option	Operating Condition	MOQ / Multiple
CMT2157A-ESR ^[1]	240 – 960 MHz (G)FSK/OOK Stand-Alone Transmitter with Encoder	SOP14	Tape & Reel	1.8 to 3.6 V, -40 to 85 °C	2,500
CMT2157A-ESB ^[1]	240 – 960 MHz (G)FSK/OOK Stand-Alone Transmitter with Encoder	SOP14	Tube	1.8 to 3.6 V, -40 to 85 °C	1,000

Note:

[1]. “E” stands for extended industrial product grade, which supports the temperature range from -40 to +85 °C.

“S” stands for the package type of SOP14.

“R” stands for the tape and reel package option, the minimum order quantity (MOQ) for this option is 2,500 pcs. “B” stands for the tube package option, with the MOQ of 1,000 pcs.

The default frequency for CMT2157A is 868.35 MHz, for the other settings, please refer to the Table 10 of Page 13.

Visit www.cmostek.com to know more about the product and product line.

Contact sales@cmostek.com or your local sales representatives for more information.

7. Package Outline

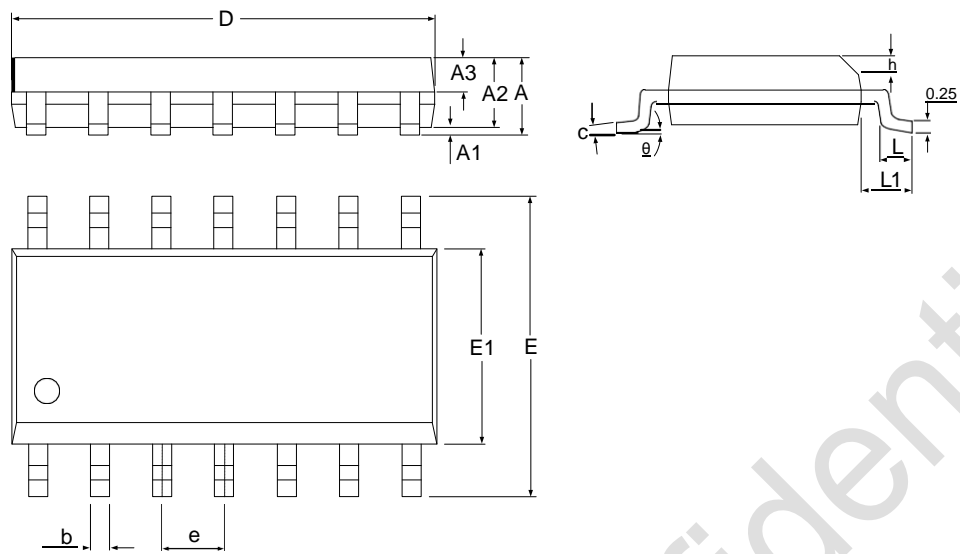

Figure 29. 14-Pin SOP Package

Table 20. 14-Pin SOP Package Dimensions

Symbol	Size (millimeters)		
	Min	Typ	Max
A	-	-	1.75
A1	0.05	-	0.225
A2	1.30	1.40	1.50
A3	0.60	0.65	0.70
b	0.39	-	0.48
C	0.21	-	0.26
D	8.45	8.65	8.85
E	5.80	6.00	6.20
E1	3.70	3.90	4.10
e	1.27 BSC		
h	0.25	-	0.50
L	0.30	-	0.60
L1	1.05 BSC		
θ	0	-	8°

8. Top Marking

8.1 CMT2157A Top Marking

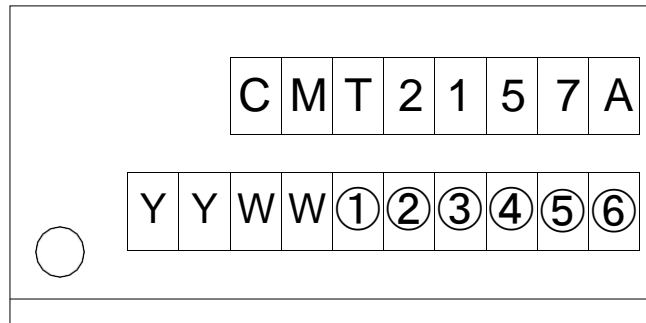

Figure 30. CMT2157A Top Marking

Table 21. CMT2157A Top Marking Explanation

Mark Method :	Laser
Pin 1 Mark :	Circle's diameter = 1 mm
Font Size :	0.35 mm, right-justified
Line 1 Marking :	CMT2157A, represents part number CMT2157A
Line 2 Marking :	YYWW is the Date code assigned by the assembly house. YY represents the last two digits of the mold year and WW represents the workweek ①②③④⑤⑥ is the internal tracking number

9. Other Documentations

Table 22. Other Documentations for CMT2157A

Brief	Name	Descriptions
AN100	CMT211x5x8x Transmitter Chip Schematic and PCB Layout Design Guide	Details of CMT211x5x8x PCB schematic and layout design rules, RF matching network and other application layout design related issues.
AN113	CMT2150A/2250(1)A One-Way RF Link Development Kits User's Guide	User's Guides for CMT2150A/2250(1)A Development Kits, including Evaluation Board and Evaluation Module, CMOSTEK USB Programmer and RFPDK.
AN115	Pairing CMT215x and CMT225x	Provide quick guideline in how to pair the CMT2150/57A with CMT2250/51A.

10. Revise History

Table 23. Revise History Records

Rev. No.	Chapter	Description of Changes	Date
0.8	All	Initial released version	2015-02-11
0.9	All	Remove AN142 document reference, change AN111 document reference to AN100.	2020-08-11

CMOSTEK Confidential

11. Contacts

CMOSTEK Microelectronics Co., Ltd. Shenzhen Branch

Address: 30th floor of 8th Building, C Zone, Vanke Cloud City, Xili Sub-district, Nanshan, Shenzhen, GD, P.R. China

Tel: +86-755-83231427

Post Code: 518055

Sales: sales@cmostek.com

Supports: support@cmostek.com

Website: www.cmostek.com

Copyright. CMOSTEK Microelectronics Co., Ltd. All rights are reserved.

The information furnished by CMOSTEK is believed to be accurate and reliable. However, no responsibility is assumed for inaccuracies and specifications within this document are subject to change without notice. The material contained herein is the exclusive property of CMOSTEK and shall not be distributed, reproduced, or disclosed in whole or in part without prior written permission of CMOSTEK. CMOSTEK products are not authorized for use as critical components in life support devices or systems without express written approval of CMOSTEK. The CMOSTEK logo is a registered trademark of CMOSTEK Microelectronics Co., Ltd. All other names are the property of their respective owners.