

240 MHz-960 MHz Single Chip OOK Transmitter with Encoder

Instruction:

CMT2157B is a single chip, high flexibility, ultra-low power consumption, OOK RF chip with encoder. It is ideal for wireless applications between 240 MHz to 960 MHz. The chip is fully compatible with the most commonly used coding formats such as 527, 1527, 2262 and 2240 in the market. In addition, it also supports various user-defined coding. The chip supports 4 freestanding buttons or up to 10 scanning buttons. Every key value can be individually configured. There is no diode isolation between the key combinations. The chip defaults to 1527 encoding and operates at 433.92 MHz when it is shipped. Users can also use the visual operation interface RFPDK and the burner provided by CMOSTEK to solidify the customized parameters into the EEPROM inside the chip to realize the differential applications. CMT2157B is one of the NextGenRF™ series products of CMOSTEK. When it is paired with the CMT221x series receiver chip, the low cost, low power consumption and high performances required by the user can be effectively met.

Applications:

- Low cost applications in the consumer electronics and appliances
- Automatic control of homes and buildings
- Fan remote control
- Infrared transmitter replacement
- Industrial monitoring and control
- Wireless lighting control system
- Wireless alarm and security system
- Remote Keyless Entry (RKE)

Features:

- Build-in EEPROM
 - Simplify the engineering development by using RFPDK
 - All functions can be configured
- Working frequency: 240 MHz ~960 MHz
- Symbol rate: 0.5 - 40 kbps
- Output power: 0 - +13 dBm
- Working current: 5.5 mA @ +10 dBm
- Sleep current: < 20 nA
- The chip runs independently without external MCU control.
- Support the common encodings such as 527, 1527, 2240, 2262 and the packet formats defined by users.
- 4 independent pins support as many as 10 buttons, key values can be arbitrary.
 - LED instruction when transmitting.
- FCC / ETSI Compliant
- RoHS Compliant
- SOP package with 14 pins

Ordering information

Product No.	Frequency	Package	MOQ
CMT2157B-ESR	433.92 MHz	SOP14 / Braid	2,500pcs

For more ordering information, please see page18.



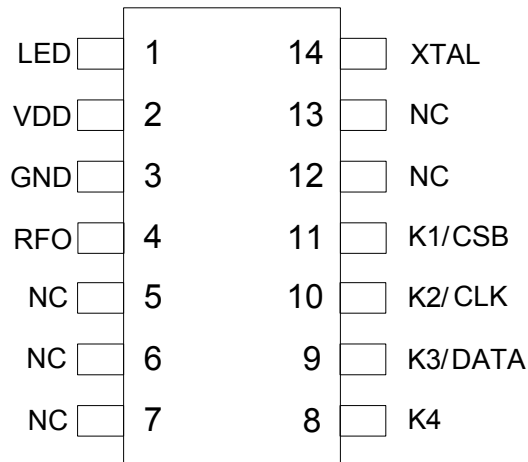

CMT2157B PIN ARRANGEMENT DIAGRAM

Pin No.	Name	I/O	Description
1	LED	IO	LED driving Burner port and enabled pin
2	VDD	I	Supply voltage input
3	GND	I	Ground
4	RFO	O	RF output
5,6,7,12,13	NC	-	No connected
8	K4	I	Button 4
9	K3	I	Button 3, DATA pin of burner port. Used to burn EEPROM.
10	K2	I	Button 2, CLK pin of burner port. Used to burn EEPROM.
11	K1	I	Button 1, CSB pin of burner port. Used to burn EEPROM.
14	XTAL	I	Crystal pin. Connect the crystal oscillator of the 15PF load capacitor to ground, or connect a suitable external clock source.

Typical Application:

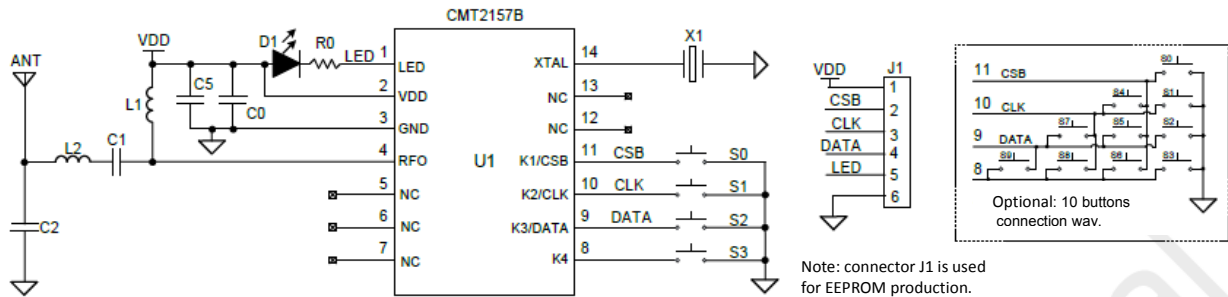

Figure1. CMT2157B Typical Application Schematic Diagram

Table1. 315 MHz /433.92 MHz Low Cost Application BOM

No.	Description	Component Value		Unit	Supplier
		315MHz	433.92MHz		
U1	CMT2157B, 240-960 MHz independent OOK transmitter with encoder	-	-	-	CMOSTEK
X1	±20 ppm, SMD32*25 mm crystal, load cap =15pF	26.250	26.2982	MHz	EPSON
C0	±20%, 0402 X7R, 25 V	0.1		uF	Murata GRM15
C5	±20%, 0402 X7R, 25 V	1		nF	Murata GRM15
C1	±5%, 0402 NP0, 50 V	82	82	pF	Murata GRM15
C2	±5%, 0402 NP0, 50 V	9.1	9.1	pF	Murata GRM15
L1	±5%, 0603 stacked inductor	180	180	nH	Murata LQG18
L2	±5%, 0603 stacked inductor	39	27	nH	Murata LQG18
D1	D0603, red LED	-	-	-	-
R0		0		Ω	
S[9:0]	Button	-	-	-	-

Terminology:

The terminologies used in this article are described below:

AN	Application note	PA	Power amplifier
BOM	Bill of material	PC	Personal computer
BSC	Basic Spacing between Centers	PCB	Printed circuit board
BW	Bandwidth	PLL	Phase-locked loop
DC	Direct current	PN	Phase noise
EEPROM	Electrically erasable programmable read-only memory	RBW	Resolution bandwidth
ESD	Electro-Static discharge	RCLK	Reference clock
ESR	Equivalent series resistance	RF	Radio frequency
GUI	Graphical user interface	RFPDK	RF product development kit
IC	Integrated circuit	RoHS	Restriction of hazardous substances
LDO	Low Dropout Regulator	RSSI	Received signal strength indicator
Max	Maximum	Rx	Receiving, Receiver
MCU	Microcontroller unit	SOP	Small outline package
Min	Minimum	Tx	Transmitting, Transmitter
MOQ	Minimum order quantity	Typ	Typical
NP0	Temperature compensation characteristic	XOSC	Crystal oscillator
OBW	Occupied bandwidth	XTAL/Xtal	Crystal
OOK	On-off keying		

Table of Contents

1. Electrical Characteristics	6
1.1 Recommended Operating Conditions	6
1.2 Absolute Maximum Rating	6
1.3 Transmitter Specification.....	7
1.4 Crystal Oscillator.....	8
2. Pin Description	9
3. Typical Performance	10
4. Typical Application Schematic Diagram	11
5. Function Description	12
5.1 Summary.....	12
5.2 Modulation, Frequency and Symbol Rate	13
5.3 RFPDK and Built-in EEPROM.....	13
5.4 Power Amplifier	16
5.5 Running State	16
6. Ordering Information	18
7. Packaging Information	19
8. Top Marking	20
9. Other Documents	21
10. Document Modification Record	22
11. Contact Information	23

1. Electrical Characteristics

When $V_{DD} = 3.3V$, $T_{OP} = 25\text{ }^{\circ}C$, $F_{RF} = 433.92\text{ MHz}$, the output power is +10 dBm. The matching impedance is $50\ \Omega$. All results are tested on the CMT2157B-EM unless otherwise stated.

1.1 Recommended Operating Conditions

Table2. Recommended Operating Conditions

Parameter	Symbol	Condition	Min.	Typ.	Max.	Unit
Operating supply voltage	V_{DD}		1.8		3.6	V
Operating temperature	T_{OP}		-40		85	$^{\circ}C$
Supply voltage slope			1			mV/us

1.2 Absolute Maximum Rating

Table3. Absolute Maximum Rating^[1]

Parameter	Symbol	Condition	Min.	Max.	Unit
Supply voltage	V_{DD}		-0.3	3.6	V
Interface voltage	V_{IN}		-0.3	$V_{DD} + 0.3$	V
Junction temperature	T_J		-40	125	$^{\circ}C$
Storage temperature	T_{STG}		-50	150	$^{\circ}C$
Welding temperature	T_{SDR}	Last at least 30 seconds		255	$^{\circ}C$
ESD grade ^[2]		Human Body Model (HBM)	-2	2	kV
Latching current		@ 85 $^{\circ}C$	-100	100	mA

Remarks:

[1]. Exceeding the "absolute maximum rating" may cause the permanent damage to the device. This value is a pressure rating and does not mean that the equipment function is affected under this pressure condition. But if the device is exposed in the absolute maximum rating condition for a long time, its reliability may be affected.

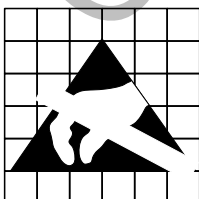

Warning! It is ESD sensitive device. In the operation of the chip, the user should pay attention to ESD precautions, so as to avoid the chip performance degradation or loss of function.

1.3 Transmitter Specification

Table4. Transmitter Specification

Parameter	Symbol	Condition	Min.	Typ.	Max.	Unit
Frequency range ^[1]	F _{RF}		240		960	MHz
Maximum output power	P _{OUT(Max)}			+13		dBm
Minimum output power	P _{OUT(Min)}			0		dBm
Output power step	P _{STEP}			1		dB
Working current ^[2] @ 315 MHz	I _{DD-315}	0 dBm		3.2		mA
		+10 dBm		7.0		mA
		+13 dBm		8.0		mA
Working current ^[2] @ 433.92 MHz	I _{DD-433.92}	0 dBm,		3.5		mA
		+10 dBm		7.5		mA
		+13 dBm		8.5		mA
Sleep current	I _{SLEEP-Push}	Push button		20		nA
	I _{SLEEP-Scan}	Scan button		1		uA
Symbol rate	DR		0.5		40	kbps
Phase noise	PN	100 kHz frequency deviation		80		dBc/Hz
		200 kHz frequency deviation		83		dBc/Hz
		400 kHz frequency deviation		91		dBc/Hz
		600 kHz frequency deviation		96		dBc/Hz
		1.2 MHz frequency deviation		105		dBc/Hz
315 MHz Harmonic output ^[3]	H ₂₃₁₅	2 harmonic @ 630 MHz, +13 dBm P _{OUT}		< -45		dBm
	H ₃₃₁₅	3 harmonic @ 945 MHz, +13 dBm P _{OUT}		< -45		dBm
433.92 MHz Harmonic output ^[3]	H _{2433.92}	2 harmonic @ 867.84 MHz, +13 dBm P _{OUT}		< -45		dBm
	H _{3433.92}	3 harmonic @ 1301.76 MHz, +13 dBm P _{OUT}		< -45		dBm
OOK extinction ratio				60		dB
315 MHz Occupied bandwidth	F _{OBW315}	Tested at -20 dBc, RBW = 1 kHz, SR = 1.2 kbps, t _{RAMP} = 256 us conditions.		6		kHz
433.92 MHz Occupied bandwidth	F _{OBW433.92}	Tested at -20 dBc, RBW = 1 kHz, SR = 1.2 kbps, t _{RAMP} = 256 us conditions.		7		kHz
Remarks:						
[1]. The frequency range is continuous within the specified range, and the frequency change depends on the crystal.						
[2]. The test conditions for operating current are as follows: 1527 packet format, independent key mode, three buttons, Sync ID=0x35AC6 (logic 1 and logic 0 each account for half), no LED.						
[3]. Harmonic output is measured by using the CMT2157B-EM evaluation board.						

1.4 Crystal Oscillator

Table5. Crystal Oscillator Specification

Parameter	Symbol	Condition	Min.	Typ.	Max.	Unit
Crystal frequency ^[1]	F _{XTAL-H}			26		MHz
	F _{XTAL-L}			13		MHz
Crystal frequency accuracy ^[2]				±20		ppm
Load capacitance ^[3]	C _{LOAD}			15		pF
Crystal equivalent resistance	R _m				60	Ω
Crystal start-up time ^[4]	t _{XTAL}			400		us
<p>Remarks:</p> <p>[1]. The CMT2150L can use the external reference clock to drive the XIN pin through the coupling capacitor. The peak value of the external clock signal is between 0.3 and 0.7V. The typical value 26MHz or 13MHz is the reference prototype for design theory. The specific crystal frequency depends on the operating frequency. Need to be calculated by RFPDK setup.</p> <p>[2]. The values include: (1) initial error, (2) crystal load, (3) ageing and (4) the acceptable crystal frequency error with temperature. It is limited by the receiver's bandwidth and the RF frequency deviation between the transmitter and the receiver.</p> <p>[3]. The required crystal load capacitance is integrated inside the chip, so as to reduce the number of external components.</p> <p>[4]. The parameter is largely related to the crystal.</p>						

2. Pin Description

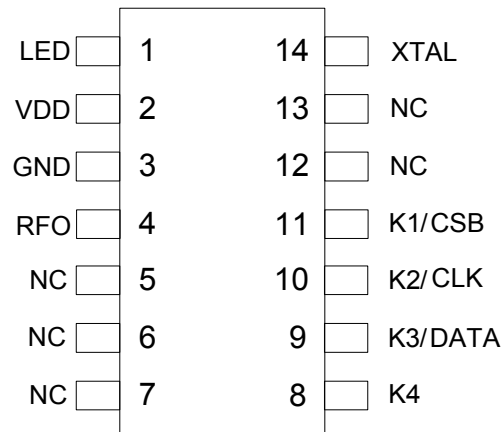

Figure2. CMT2157B Pin Arrangement

Table6. CMT2157B Pin Description

Pin No.	Name	I/O	Description
1	LED	IO	LED driving Burner port and enabled pin
2	VDD	I	Supply voltage input
3	GND	I	Ground
4	RFO	O	RF output
5,6,7,12,13	NC	-	No connected
8	K4	I	Button 4
9	K3	I	Button 3, DATA pin of burner port. Used to burn EEPROM.
10	K2	I	Button 2, CLK pin of burner port. Used to burn EEPROM.
11	K1	I	Button 1, CSB pin of burner port. Used to burn EEPROM.
14	XTAL	I	Crystal pin. Connect the crystal oscillator of the 15PF load capacitor to ground, or connect a suitable external clock source.

3. Typical Performance

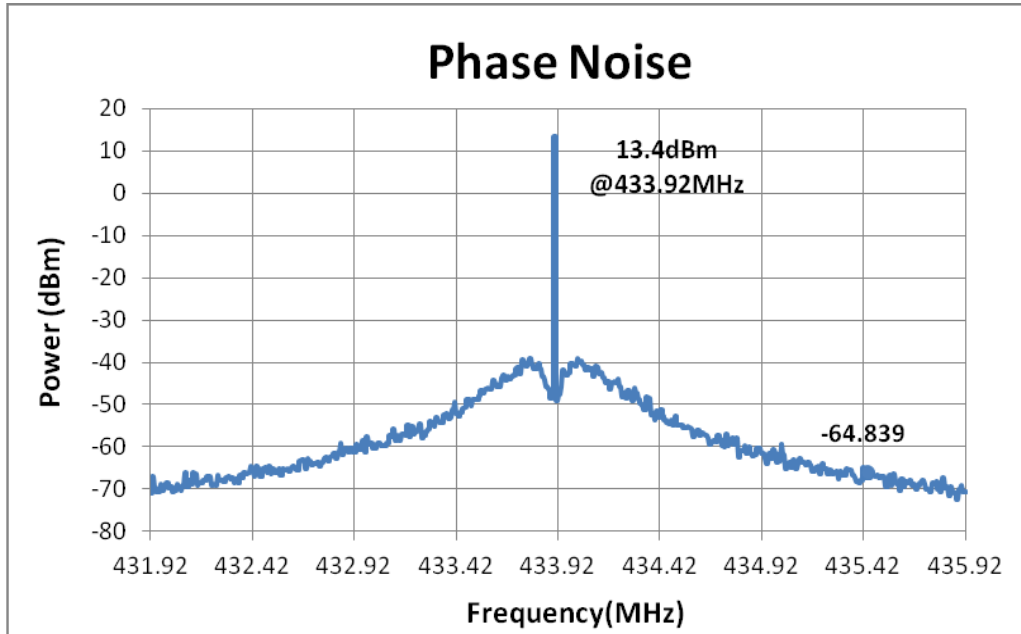

Figure3. Phase Noise, $F_{RF} = 433.92 \text{ MHz}$, $P_{OUT} = +13 \text{ dBm}$, Single Carrier

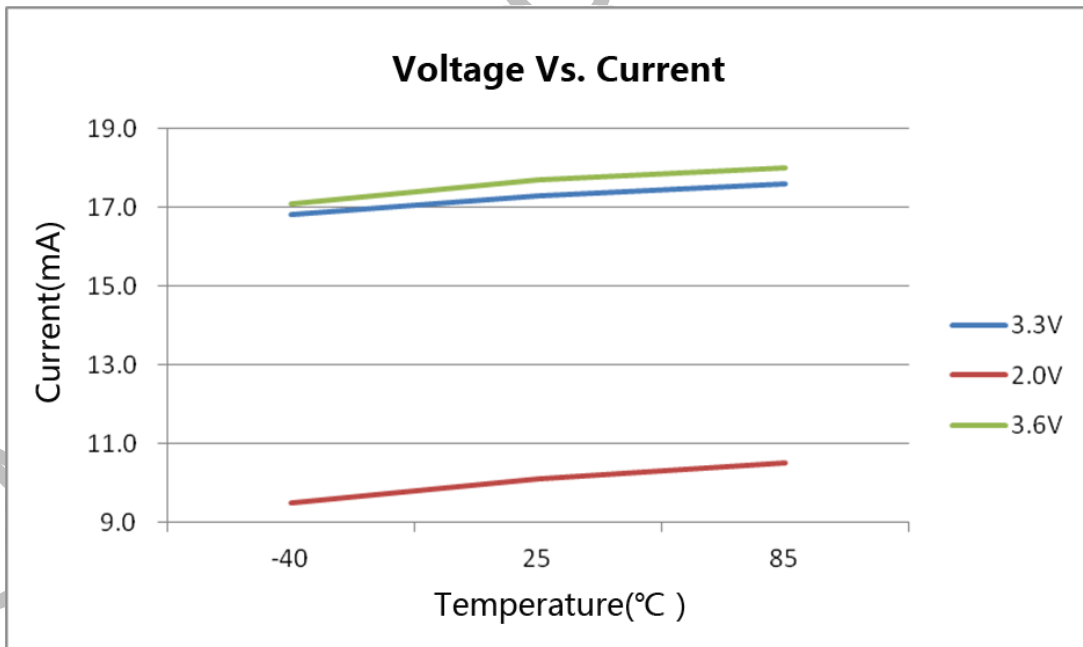

Figure4. Tx power-Current-Voltage Characteristic Diagram

$F_{RF} = 433.92 \text{ MHz}$, $P_{OUT} = +13 \text{ dBm}$, Single Carrier (No Encoding)

4. Typical Application Schematic Diagram

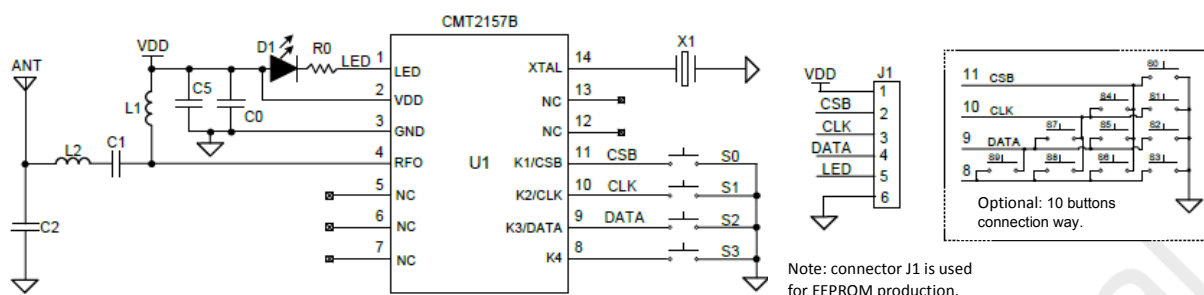

Figure5. CMT2157B Typical Application Schematic Diagram

Application Notes:

- Connector J1 is required for EEPROM burned during the development and production.
- The PCB LAYOUT rules are shown below:
 - Try to design the large and continuous ground.
 - Try to design the ground vias (Especially around the GND pin) to reduce the series parasitic inductance between the GND pin and the floor.
 - Try to avoid designing the long and thin transmission track to connect components.
 - The adjacent inductors should be placed perpendicular to each other to reduce the mutual coupling.
 - C0 is as close to CMT2157B as possible to achieve the better filtering result.
 - The crystal X1 is as close as possible to the chip. The metal case is grounded. It is away from the RF output signal and the digital signal.
- For more details on the design, please refer to the **AN155 CMT2157B/CMT2150L schematic and the PCB layout guidelines.**

Table7. 315 MHz /433.92 MHz Typical Application BOM

No.	Description	Component Value		Unit	Supplier
		315MHz	433.92MHz		
U1	CMT2157B, 240-960 MHz independent OOK transmitter with encoder	-		-	CMOSTEK
X1	±20 ppm, SMD32*25 mm crystal, load cap =15pF	26.250	26.2982	MHz	EPSON
C0	±20%, 0402 X7R, 25 V	0.1		uF	Murata GRM15
C5	±20%, 0402 X7R, 25 V	1		nF	Murata GRM15
C1	±5%, 0402 NP0, 50 V	82	82	pF	Murata GRM15
C2	±5%, 0402 NP0, 50 V	9.1	9.1	pF	Murata GRM15
L1	±5%, 0603 stacked inductor	180	180	nH	Murata LQG18
L2	±5%, 0603 stacked inductor	39	27	nH	Murata LQG18
D1	D0603, red LED	-		-	-
R0		0		Ω	
S[9:0]	Button	-		-	-

5. Function Description

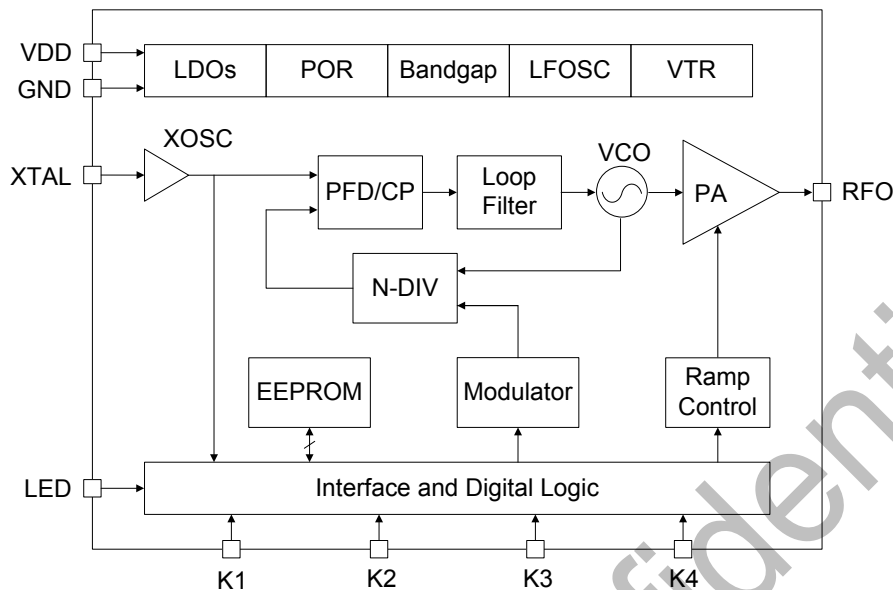

Figure6. Function Module Diagram

5.1 Summary

CMT2157B is a single chip, high flexibility, high performance, OOK transmitter with encoder. It is ideal for wireless applications ranging from 240 to 960MHz. CMT2157B is one of the NextGenRF™ series products of CMOSTEK. The family includes the complete receiver, the transmitter and the transceiver etc.. The integrated data encoder is not only compatible with the commonly used 527, 1527 and 2262 data encoding formats in the market, but also supports the user to define the encoding format arbitrarily. It's very flexible and powerful. In the scan button mode, it supports as many as 10 configurable buttons. The chip is designed for its high integration and low power consumption, especially for low cost system, low power consumption, wireless transmitting application driven by battery.

The functional block diagram of the CMT2157B is shown in figure 6. CMT2157B adopts the PLL+PA structure to realize the wireless transmitting function. It uses a single pin crystal oscillator circuit. In order to reduce the number of external components, the load capacitance required for crystal oscillation is integrated inside the chip. In each power on reset (POR), the analog module inside the chip is calibrated with an internal reference voltage source. This calibration allows the chip to work better at the different temperature and voltage. Transmitting Data is triggered by button. After the Tx data is modulated, it is transmitted by an efficient power amplifier. Its transmitting power can be set from 0dBm to +13 dBm with 1dBm as step. The user can burn the frequency, output power and other product parameters into the chip's built-in EEPROM by USB Programmer and

RFPDK. This will simplify the development and production, and reduce the cost. Alternatively, the user can directly use the spot stock with the 433.92 MHz and other default parameters to produce directly, and avoid burning in the production. CMT2157B works between 1.8V and 3.6 V. It works well until the battery voltage is used up. It transmits the 10dBm RF signal at 3.3V voltage and 433.92 MHz frequency, only consuming 8.5mA current.

5.2 Modulation, Frequency and Symbol Rate

CMT2157B supports the OOK modulation with the symbol rate up to 40 kbps. It can continuously cover the frequency from 240 MHz to 960 MHz, including 315 MHz, 433.92 MHz, 868MHz, 915MHz and other free ISM frequency bands. The modulation mode, frequency and symbol rate are listed in table 8.

Table8. Modulation Mode, Frequency and Symbol Rate

Parameter	Value	Unit
Modulation Mode	OOK	-
Frequency	240 to960	MHz
Symbol Rate	0.5 to 40	kbps

5.3 RFPDK and Built-in EEPROM

RFPDK (RF Products Development Kit) is a piece of user interface friendly software. It allows users to configure CMT2157B in the most intuitive way. Users only need to fill in or select the appropriate value for each parameter, and then click the "Burn" button to complete the chip configuration. In the specific application, users do not need to access and control any registers. The following figure shows the way to access EEPROM. Table 9 shows all the configurable parameters of CMT2157B on RFPDK.

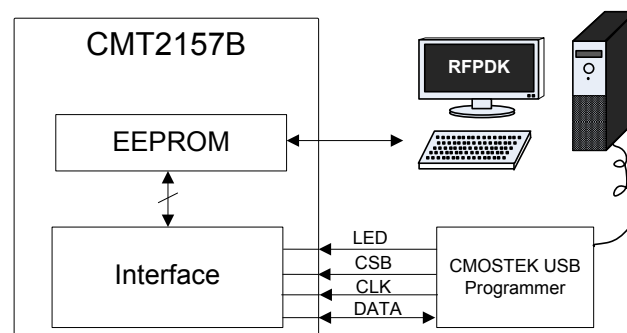

Figure7. Access the Built-in EEPROM

For details about the CMT2157B configuration, users can refer to the **AN154 CMT2157B configuration guideline**.

Table9. Configurable Parameters in RFPDK

Classification	Parameter	Description	Default
RF Settings	Frequency	Input the required RF frequency, ranging from 240 MHz to 960MHz, with an accuracy of 0.001 MHz.	433.92 MHz
	Xtal Freq. Type	Select the high frequency crystal (26MHz) or the low frequency crystal (13MHz).	High Freq.
	Xtal Freq.	Calculate the recommended crystal frequency according to the settings of Frequency and Xtal Freq.Type.	26.2982MHz
	Tx Power	Select the right output power, ranging from 0 to +14 dBm (Give the margin of 1 dBm above +13 dBm).	+13 dBm
	Symbol Rate	Set the symbol rate to be transmitted, from 0.5 kbps to 40 kbps.	4.8
Operation Setting	LED	The LED indicator shows on or off	On
	LED Output Mode	LED output mode: PWM Signal----- Output PWM waveform to drive LED, Tx Data-----Output the data stream synchronized with data to drive LED.	PWM Signal
	PWM Rate	Valid when the LED output mode is PWM. It is 3.34KHz or 6.68KHz.	6.68KHz
	PWM Ratio	Valid when the LED output mode is PWM, Set the PWM ratio, ranging from 0 to 100%	t100%
	LED Enable Mode	Valid when the LED output mode is PWM, : Tx State----- Valid in Tx state (Stop at the packet / group gap). Entire Tx Process---- Output in the entire Tx process (including packet / group gap).	Tx State
	Tx Overtime	Exit the setting when users press the button for a long time, users can set: 8s, 16S, 32S, 64S.	8s
	Packet Number Per Pressing	Pressing and transmitting message mode: Preset Length Packet: It is the fixed length mode when pressing and transmitting Variable Length Packet: The pressing is continues, the transmitting is continues. (The longest transmitting is continues until the timeout, and then exit the transmitting.)	Variable Length Packet
Baseband Settings	Tx Cycle	Packet transmitting mode, setting range 0~256: Setting=0: Turn off the packet transmitting mode; Setting≠0: Preset the number of the transmitting packet. (Preset Length Packet is valid.)	0
	Packet Number	Packet number, setting range 1~256(Can not be 0, at least 1 packet): When Tx Cycle=0, it is the presetting packet number. (Preset Length Packet is valid at the same time.) When TxCycle≠0, it is the number of packet per	2

Classification	Parameter	Description	Default
		transmitting.	
	Packet Gap	Packet / group gap, setting range 0~256. The unit is Symbol: When the packet transmitting is invalid(Tx Cycle=0), it is the packet gap. Packet transmitting is continuous without interruption; When the packet transmitting is valid(TxCycle≠0), it is the group gap. There is a pause gap between the group and the group, but the packet transmitting within the group is uninterrupted.	0
	Bit Format	Encoding logic bit length, setting range 1~8bits. For example: When Bit Format =1, NRZ encoding (non return to zero encoding); When Bit Format =2, Manchester encoding; When Bit Format ≥3, PWM encoding.	4
	Bit Logic 1	Encoding logic 1 definition. Set by Bit Format length. For example: When Bit Format=1, Bit Logic 1=0b1. When Bit Format=2, Bit Logic 1=0b10 or 0b01.	E (0b1110)
	Bit Logic 0	Encoding logic 0 definition. Set by Bit Format length. For example: When Bit Format=1, Bit Logic 0=0b0. When Bit Format=2, Bit Logic 0=0b01 or 0b10.	8 (0b1000)
	Preamble Size	Data packet / group preamble length, setting range 0 ~ 256Bytes. When it is set 0, the Preamble is disabled.	0
	Preamble Value	Preamble value, users can select 0x55 or 0xAA. The premise is that Preamble Size is not 0.	0x55
	Preamble Location	Preamble location, setting for the packet transmitting mode(TxCycle≠0). Every Packet: Every packet contained Preamble in the Tx Cycle; Every Tx Cycle: Preamble only appears in the first frame of the Tx Cycle, and thereafter the packet does not contain Preamble.	Every Packet
	Sync Size	Packet synchronization word length, setting range 0 to 32bits. Set 0, that is, the synchronous word is disabled. The maximum supports to 4Bytes.	32
	Sync Value	Synchronization word value	0x80000000
	Addr Size	Packet ID length, setting range 1 ~ 32bits. The maximum supports to 4Bytes.	0
	Addr Value	ID value	
	LBD Output Status	Low battery detection output status	Disable
	LBD Threshold	Low battery detection threshold, setting range 2.0~ 3.6V. The resolution is 0.1V.	2.4 V
	Stop Size	Packet stop bit length, setting range 0~ 16bits. Set 0, that is, the stop bit is disabled. The maximum supports to	0

Classification	Parameter	Description	Default
		2Bytes.	
	Stop Value	Stop bit value	0
Button Settings	Key Mode	Select the key mode, the option is: Scan Button——Scan button; Push Button——Direct independent key.	Push Button
	Key Value Format	Input the key value format: Hex (16 hexadecimal) or Dec (10 hexadecimal)	Hex
	Key Size	Key value length, setting range 0~8Bits. Set 0, that is, the message does not contain the key value.	4
	SWn	Each key value	

5.4 Power Amplifier

CMT2157B integrates a high-efficiency Class-E power amplifier. The RFPDK setting allows the PA to go from 0dBm to +13dBm, step 1dBm. For the peripheral matching of this PA, please refer to the **AN155 CMT2157B/CMT2150L schematic and the PCB layout design guideline**.

5.5 Running State

When the CMT2157B is powered up, follow the operating state shown in the diagram below:

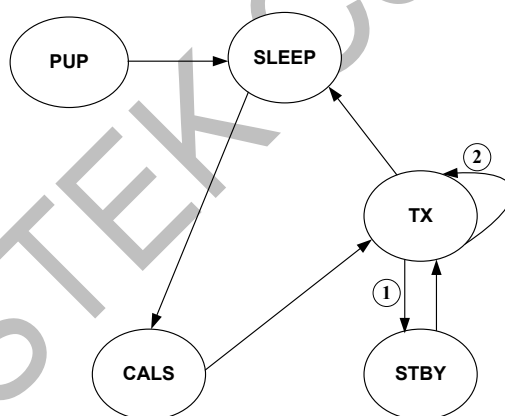

Figure8. Running State

Power Up State

Once the power is switched on, the chip will complete the power up (PUP) process. It includes the release of power on reset (POR), the opening of the crystal circuit and the calibration of the internal circuitry. PUP will take about 6ms.

Sleep State

In this state, all the internal circuit modules are closed (Enable the scan button mode; and the scan circuit is still working). In sleep, the chip consumes about 20 nA (Push Key mode).

Calibration State

The chip starts the crystal to stabilize the oscillation, then calibrates and copies the corresponding content according to the EEPROM setting parameter. It usually takes about 800 us to complete the process.

Tx State

After calibrating, the chip enters the Tx state.

Standby State

This is the temporary state of the entire Tx process. It mainly appears in the packet gap (non packet mode, TX-Cycle disabled) or group gap (packet mode, TX-Cycle enabled). The aim is to reduce the power consumption during the TX process.

CMOSTEK Confidential

6. Ordering Information

Table10. CMT2157B Ordering Information

Product No.	Description	Package	Packing	Operation Condition	MOQ/ Integer times
CMT2157B-ESR ^[1]	Low cost 315/433.92 MHz OOK receiver	SOP14	Taping	1.8 to 3.6 V, -40 to 85 °C	2,500
Remarks: [1]. "E" stands for the extended industrial grade with a temperature range of -40 to +85. "S" stands for the package type of SOP8. "R" stands for the braid and tape type. MOQ is 2500pcs; "B" stands for the tube type. MOQ is 1000pcs					

For more information on products and product lines, please visit www.cmostek.com.

For purchasing or price requirements, please contact sales@cmostek.com or local sales representative.

7. Packaging Information

CMT2157B package SOP14 related packaging information, as shown in the following figure and the following table.

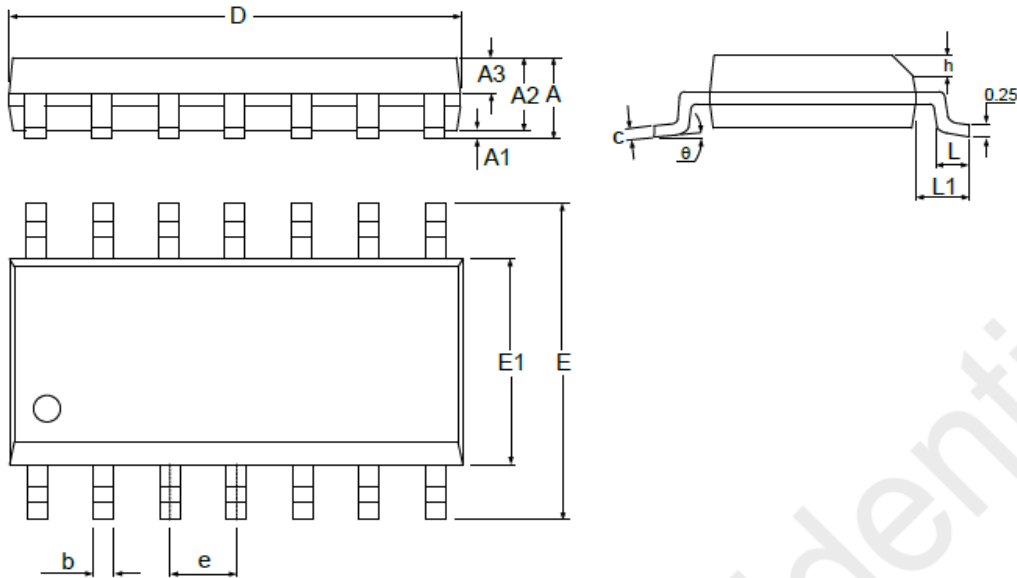

Figure9. 14-Pin SOP Package

Table11. SOP14 Package Size

Symbol	Size(mm)		
	Min.	Typ.	Max.
A	-	-	1.75
A1	0.05	-	0.225
A2	1.30	1.40	1.50
A3	0.60	0.65	0.70
b	0.39	-	0.48
c	0.21	-	0.26
D	8.45	8.65	8.85
E	5.80	6.00	6.20
E1	3.70	3.90	4.10
e	1.27 BSC		
h	0.25	-	0.50
L	0.50	-	0.60
L1	1.05 BSC		
θ	0	-	8°

8. Top Marking

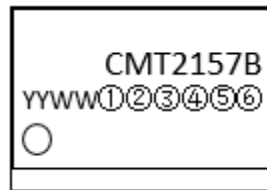

Figure10. CMT2157B Top Marking

Table12. CMT2157B Top Marking Description

Silk-print Pattern	Laser
Pin 1 mark	Circle diameter = 1 mm
Font height	0.6 mm, right aligned.
Font width	0.4 mm
Line 1 marking	CMT2157B stands for the model CMT2157B
Line 2 marking	YYWW is the date number set by the packaging factory. YY stands for the last 2 digits of the year, and WW stands for the working week. ①②③④⑤⑥ is the internal tracking coding.

9. Other Documents

Table13. Other documents related with CMT2157B

Doc. No.	Doc. Name	Description
AN154	CMT2157B Configuration Guideline	Configuring CMT2157B through RFPDK is described in detail.
AN155	CMT2157B/2150L schematic and the PCB layout guideline	CMT2157B and CMT22150L PCB schematics and the layout design rules, RF matching networks and other layout design considerations.
AN159	CMT2157B/2150L matching guideline	Matching guideline for CMT2157B/2150L.

CMOSTEK Confidential

10. Document Modification Record

Table14. Document Modification Record Sheet

Version	Chapter	Modification descriptions	Date
0.1	All	Initial release	2017-10-08

CMOSTEK Confidential

11. Contact Information

Wuxi CMOSTEK Microelectronics Co., Ltd. Shenzhen branch

Room 203, Honghai Building, Qianhai Road, Nanshan District, Shenzhen, Guangdong, China

Zip Code: 518000

Tel: +86 - 755 - 83235017

Fax: +86 - 755 - 82761326

Sales: sales@cmostek.com

Technical support: support@cmostek.com

Website: www.cmostek.com

CMOSTEK Confidential

Copyright. CMOSTEK Microelectronics Co., Ltd. All rights are reserved.

The information furnished by CMOSTEK is believed to be accurate and reliable. However, no responsibility is assumed for inaccuracies and specifications within this document are subject to change without notice. The material contained herein is the exclusive property of CMOSTEK and shall not be distributed, reproduced, or disclosed in whole or in part without prior written permission of CMOSTEK. CMOSTEK products are not authorized for use as critical components in life support devices or systems without express written approval of CMOSTEK. The CMOSTEK logo is a registered trademark of CMOSTEK Microelectronics Co., Ltd. All other names are the property of their respective owners.