

Low-Cost 300 – 480 MHz (G)FSK/OOK Stand-Alone RF Receiver

Features

- Embedded EEPROM
 - Very Easy Development with RFPDK
 - All Features Programmable
- Frequency Range: 300 to 480 MHz
- FSK, GFSK and OOK Demodulation
- Symbol Rate: 0.1 to 100 ksps
- Sensitivity: -111 dBm @ 9.6 ksps, FSK, 433.92 MHz
- 3-wire SPI Interface for EEPROM Programming
- Stand-Alone, No External MCU Control Required
- Configurable Duty-Cycle Operation Mode
- Supply Voltage: 1.8 to 3.6 V
- Low Power Consumption: 4.3 mA @ 433.92 MHz, FSK
- Low Sleep Current
 - 60 nA when Sleep Timer Off
 - 440 nA when Sleep Timer On
- RoHS Compliant
- 16-pin QFN 3x3 Package

Descriptions

The CMT2213AW is an ultra low power, high performance, low-cost (G)FSK/OOK stand-alone RF receiver for various 300 to 480 MHz wireless applications. It is part of the CMOSTEK NextGenRF™ family, which includes a complete line of transmitters, receivers and transceivers. An embedded EEPROM allows the frequency, symbol rate and other features to be programmed into the device using the CMOSTEK USB Programmer and RFPDK. Alternatively, in stock products of 433.92 MHz is available for immediate demands with no need of EEPROM programming. The CMT2213AW operates from a supply voltage of 1.8 V to 3.6 V, when it is always on, it consumes only 4.3 mA current while achieving -111 dBm receiving sensitivity. It consumes even less power when working in duty-cycle operation mode via the built-in sleep timer. The device provides demodulated data, power-on reset output as well as a system clock output for use by an external microcontroller or decoder. The CMT2213AW receiver together with the CMT2113AW transmitter enables an ultra low cost RF link.

Applications

- Low-Cost Consumer Electronics Applications
- Home and Building Automation
- Infrared Receiver Replacements
- Industrial Monitoring and Controls
- Remote Automated Meter Reading
- Remote Lighting Control System
- Wireless Alarm and Security Systems
- Remote Keyless Entry (RKE)

Ordering Information

Part Number	Frequency	Package	MOQ
CMT2213AW-EQR	433.92 MHz	QFN16	5,000 pcs
More Ordering Info: See Page 20			

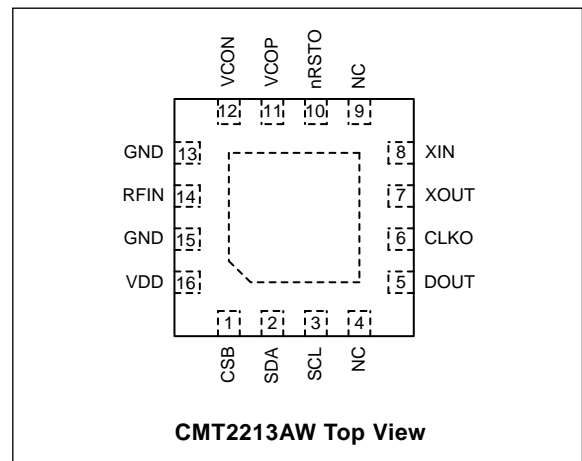

Typical Application

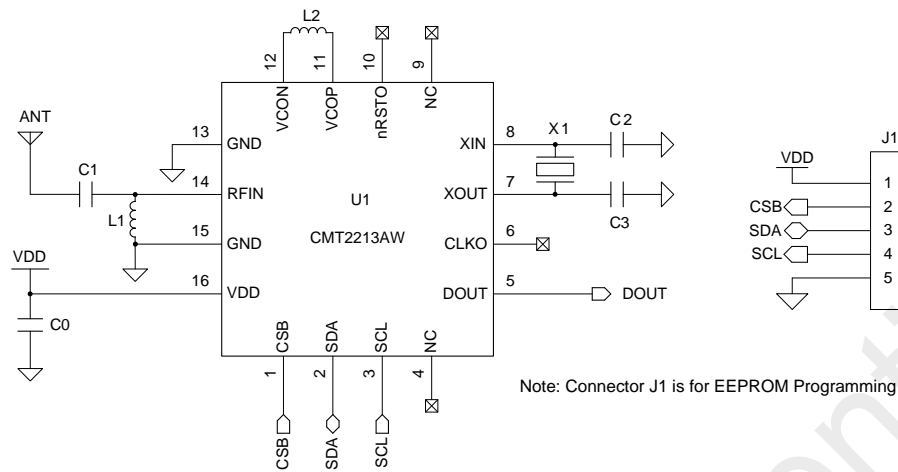

Figure 1. CMT2213AW Typical Application Schematic

Table 1. BOM of Typical Application

Designator	Descriptions	Value (Match to 50Ω ANT)		Value (Common Used ANT)		Unit	Manufacturer
		315 MHz	433.92 MHz	315 MHz	433.92 MHz		
U1	CMT2213AW, low-cost 300 – 480 MHz (G)FSK/OOK stand-alone RF receiver	-		-		-	CMOSTEK
X1	±20 ppm, SMD32*25 mm, crystal	26		26		MHz	EPSON
L1	±5%, 0603 multi-layer chip inductor	33	27	68	33	nH	Murata LQG18
L2	±5%, 0603 multi-layer chip inductor	33	22	33	22	nH	Murata LQG18
C1	±0.25 pF, 0402 NP0, 50 V	5.6	3.3	4.3	2.7	pF	Murata GRM15
C0	±20%, 0402 X7R, 25 V	0.1		0.1		uF	Murata GRM15
C2, C3	±5%, 0402 NP0, 50 V	27		27		pF	Murata GRM15

Abbreviations

Abbreviations used in this data sheet are described below

AGC	Automatic Gain Control	OOK	On-Off Keying
AN	Application Notes	PC	Personal Computer
BER	Bit Error Rate	PCB	Printed Circuit Board
BOM	Bill of Materials	PLL	Phase Lock Loop
BSC	Basic Spacing between Centers	PN9	Pseudorandom Noise 9
BW	Bandwidth	POR	Power On Reset
DC	Direct Current	PUP	Power Up
EEPROM	Electrically Erasable Programmable Read-Only Memory	QFN	Quad Flat No-lead
ESD	Electro-Static Discharge	RF	Radio Frequency
ESR	Equivalent Series Resistance	RFPDK	RF Products Development Kit
Ext	Extended	RoHS	Restriction of Hazardous Substances
FSK	Frequency-Shift Keying	RSSI	Received Signal Strength Indicator
GFSK	Gauss frequency Shift Keying	Rx	Receiving, Receiver
IF	Intermediate Frequency	SAR	Successive Approximation Register
LNA	Low Noise Amplifier	SPI	Serial Port Interface
LO	Local Oscillator	TH	Threshold
LPOSC	Low Power Oscillator	Tx	Transmission, Transmitter
Max	Maximum	Typ	Typical
MCU	Microcontroller Unit	USB	Universal Serial Bus
Min	Minimum	VCO	Voltage Controlled Oscillator
MOQ	Minimum Order Quantity	WOR	Wake On Radio
NP0	Negative-Positive-Zero	XOSC	Crystal Oscillator
NC	Not Connected	XTAL/Xtal	Crystal

Table of Contents

1. Electrical Characteristics	5
1.1 Recommended Operation Conditions	5
1.2 Absolute Maximum Ratings.....	5
1.3 Receiver Specifications	6
1.4 Crystal Oscillator	7
1.5 LPOSC	7
2. Pin Descriptions	8
3. Typical Performance Characteristics	9
4. Typical Application Schematic	10
5. Functional Descriptions	11
5.1 Overview	11
5.2 Modulation, Frequency Deviation and Symbol Rate	11
5.3 Embedded EEPROM and RFPDK	12
5.4 All Configurable Options	12
5.5 Internal Blocks Description.....	14
5.5.1 RF Front-end and AGC	14
5.5.2 IF Filter.....	14
5.5.3 RSSI	15
5.5.4 SAR ADC	15
5.5.5 Crystal Oscillator.....	15
5.5.6 Frequency Synthesizer	15
5.5.7 LPOSC.....	16
5.6 Operation Mode	16
5.7 Always Receive Mode.....	17
5.8 Duty-Cycle Receive Mode.....	17
5.9 Easy Duty-Cycle Configurations.....	18
5.10 The nRSTO	18
5.11 The CLKO	19
6. Ordering Information	20
7. Package Outline	21
8. Top Marking	22
8.1 CMT2213AW Top Marking.....	22
9. Other Documentations	23
10. Document Change List	24
11. Contact Information	25

1. Electrical Characteristics

$V_{DD} = 3.3\text{ V}$, $T_{OP} = 25\text{ }^{\circ}\text{C}$, $F_{RF} = 433.92\text{ MHz}$, sensitivities are measured in receiving a PN9 sequence and matching to $50\ \Omega$ impedance, with the BER of 0.1%. All measurements are performed using the board CMT2213AW-EM V1.0, unless otherwise noted.

1.1 Recommended Operation Conditions

Table 2. Recommended Operation Conditions

Parameter	Symbol	Conditions	Min	Typ	Max	Unit
Operation Voltage Supply	V_{DD}		1.8		3.6	V
Operation Temperature	T_{OP}		-40		85	$^{\circ}\text{C}$
Supply Voltage Slew Rate			1			mV/us

1.2 Absolute Maximum Ratings

Table 3. Absolute Maximum Ratings^[1]

Parameter	Symbol	Conditions	Min	Max	Unit
Supply Voltage	V_{DD}		-0.3	3.6	V
Interface Voltage	V_{IN}		-0.3	$V_{DD} + 0.3$	V
Junction Temperature	T_J		-40	125	$^{\circ}\text{C}$
Storage Temperature	T_{STG}		-50	150	$^{\circ}\text{C}$
Soldering Temperature	T_{SDR}	Lasts at least 30 seconds		255	$^{\circ}\text{C}$
ESD Rating ^[2]		Human Body Model (HBM)	-2	2	kV
Latch-up Current		@ 85 $^{\circ}\text{C}$	-100	100	mA

Notes:

- [1]. Stresses above those listed as “absolute maximum ratings” may cause permanent damage to the device. This is a stress rating only and functional operation of the device under these conditions is not implied. Exposure to maximum rating conditions for extended periods may affect device reliability.
- [2]. The CMT2213AW is high-performance RF integrated circuits with VCON/P pins having an ESD rating < 2 kV HBM. Handling and assembly of this device should only be done at ESD-protected workstations.

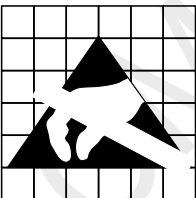

Caution! ESD sensitive device. Precaution should be used when handling the device in order to prevent permanent damage.

1.3 Receiver Specifications

Table 4. Receiver Specifications

Parameter	Symbol	Conditions	Min	Typ	Max	Unit
Frequency Range	F_{RF}		300		480	MHz
Symbol Rate	SR	OOK demodulation	0.1		40	ksps
		(G)FSK demodulation	0.1		100	ksps
Deviation	F_{DEV}	(G)FSK	1		200	kHz
Bandwidth-Time Product	BT		-	0.5	-	-
Sensitivity	$S_{315-OOK}$	315 MHz, SR = 1 ksps		-114		dBm
	$S_{433.92-OOK}$	433.92 MHz, SR = 1 ksps		-113		dBm
	$S_{315-FSK}$	315 MHz, SR = 9.6 ksps, $F_{DEV} = 19.2$ kHz		-112		dBm
	$S_{433.92-FSK}$	433.92 MHz, SR = 9.6 ksps, $F_{DEV} = 19.2$ kHz		-111		dBm
Saturation Input Signal Level	P_{LVL}			10		dBm
Working Current	I_{DD-OOK}	315 MHz, OOK		3.5		mA
		433.92 MHz, OOK		3.8		mA
	I_{DD-FSK}	315 MHz, FSK		4.0		mA
		433.92 MHz, FSK		4.3		mA
Sleep Current	I_{SLEEP}	When sleep timer is on		440		nA
		When sleep timer is off		60		nA
Frequency Resolution	F_{RES}			24.8		Hz
Frequency Synthesizer Settle Time	T_{LOCK}	From XOSC settled		150		us
Blocking Immunity	BI	SR = 1 ksps, ± 1 MHz offset, CW interference		52		dB
		SR = 1 ksps, ± 2 MHz offset, CW interference		74		dB
		SR = 1 ksps, ± 10 MHz offset, CW interference		75		dB
Image Rejection Ratio	IMR	IF = 280 kHz		35		dB
Input 3 rd Order Intercept Point	IIP3	Two tone test at 1 MHz and 2 MHz offset frequency. Maximum system gain settings		-25		dBm
Receiver Bandwidth	BW		50		500	kHz
Receiver Start-up Time	$T_{START-UP}$	From power up to receive, in Always Receive Mode		7.3		ms
Receiver Wake-up Time	$T_{WAKE-UP}$	From sleep to receive, in Duty-Cycle Receive Mode		0.61		ms

1.4 Crystal Oscillator

Table 5. Crystal Oscillator Specifications

Parameter	Symbol	Conditions	Min	Typ	Max	Unit
Crystal Frequency ^[1]	F _{XTAL}		26	26	26	MHz
Crystal Tolerance ^[2]				±20		ppm
Load Capacitance	C _{LOAD}		10	15	20	pF
Crystal ESR	R _m				60	Ω
XTAL Startup Time ^[3]	t _{XTAL}			400		us
Notes:						
[1]. The CMT2213AW can directly work with external 26 MHz reference clock input to XIN pin (a coupling capacitor is required) with peak-to-peak amplitude of 0.3 to 0.7 V.						
[2]. This is the total tolerance including (1) initial tolerance, (2) crystal loading, (3) aging, and (4) temperature dependence. The acceptable crystal tolerance depends on RF frequency and channel spacing/bandwidth.						
[3]. This parameter is to a large degree crystal dependent.						

1.5 LPOSC

Table 6. LPOSC Specifications

Parameter	Symbol	Conditions	Min	Typ	Max	Unit
Calibrated Frequency ^[1]	F _{LPOSC}			1		kHz
Frequency Accuracy		After calibration		1		%
Temperature Coefficient ^[2]				-0.02		%/°C
Supply Voltage Coefficient ^[3]				+0.5		%/V
Initial Calibration Time	t _{LPOSC-CAL}			4		ms
Notes:						
[1]. The LPOSC is automatically calibrated to the crystal oscillator during the PUP state, and is periodically calibrated since then.						
[2]. Frequency drifts when temperature changes after calibration.						
[3]. Frequency drifts when supply voltage changes after calibration.						

2. Pin Descriptions

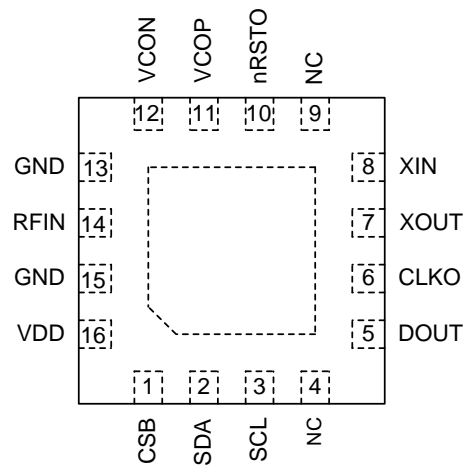

Figure 2. CMT2213AW Pin Assignments

Table 7. CMT2213AW Pin Descriptions

Pin Number	Name	I/O	Descriptions
1	CSB	I	3-wire SPI chip select input for EEPROM programming, internally pulled high
2	SDA	IO	3-wire SPI data input and output for EEPROM programming
3	SCL	I	3-wire SPI clock input for EEPROM programming, internally pulled low
4,9	NC	NA	Not connected, leave floating
5	DOUT	O	Received data output
6	CLKO	O	Programmable clock output to drive an external MCU
7	XOUT	O	Crystal oscillator output
8	XIN	I	Crystal oscillator input or external reference clock input
10	nRSTO	O	Active-low power-on-reset output to reset an external MCU
11	VCOP	IO	VCO tank, connected to an external inductor
12	VCON		
13, 15	GND	I	Ground
14	RFIN	I	RF signal input to the LNA
16	VDD	I	Power supply input

3. Typical Performance Characteristics

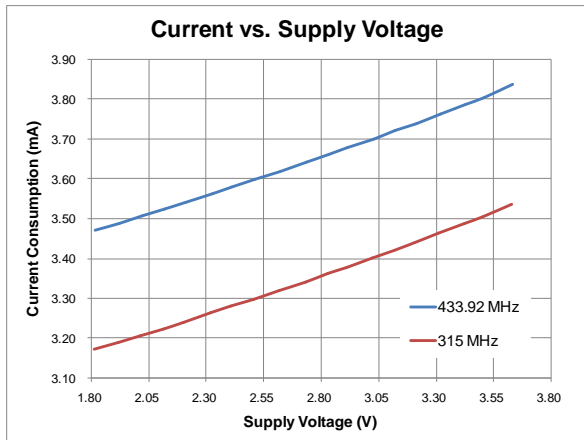

Figure 3. Current vs. Voltage, $F_{RF} = 315 / 433.92$ MHz, OOK, SR = 1 kbps

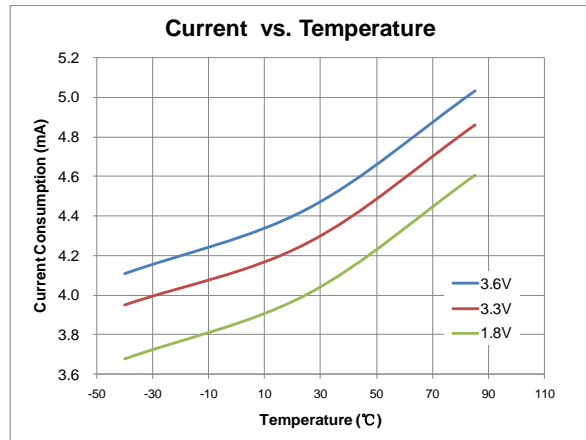

Figure 4. Current vs. Temperature, $F_{RF} = 433.92$ MHz, FSK, SR = 1 kbps

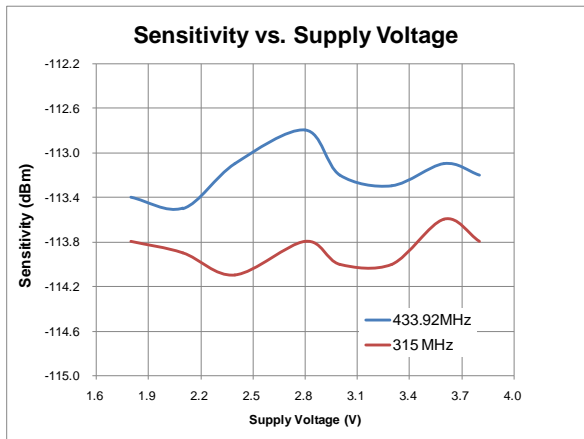

Figure 5. Sensitivity vs. Supply Voltage, SR = 1 kbps, OOK, BER = 0.1%

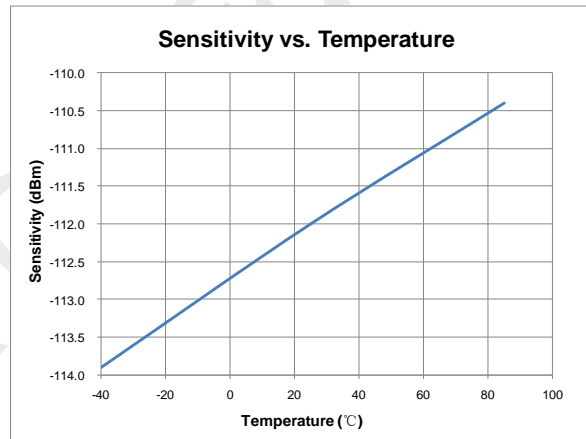

Figure 6. Sensitivity vs. Temperature, $F_{RF} = 433.92$ MHz, $V_{DD} = 3.3$ V, SR = 1 kbps, FSK, BER = 0.1%

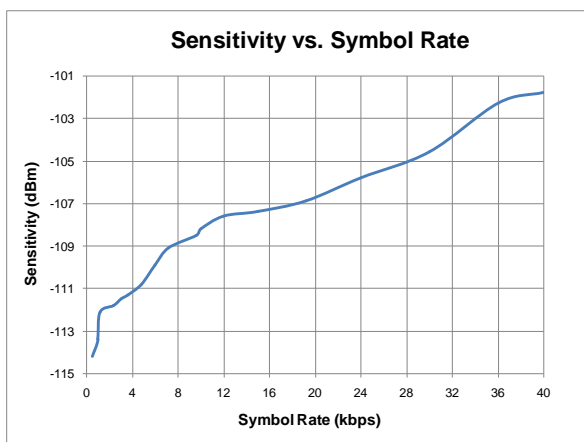

Figure 7. Sensitivity vs. SR, $F_{RF} = 433.92$ MHz, $V_{DD} = 3.3$ V, OOK, BER = 0.1%

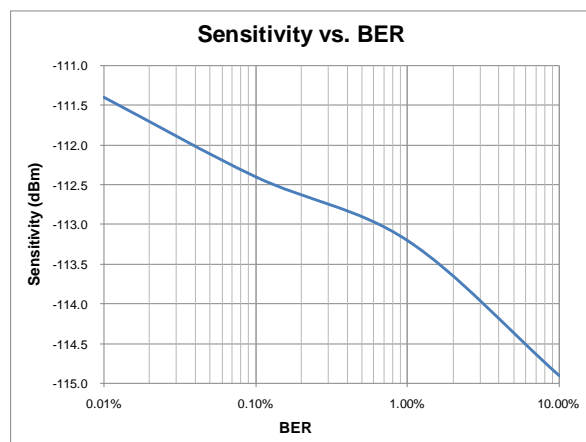

Figure 8. Sensitivity vs. BER, $F_{RF} = 433.92$ MHz, $V_{DD} = 3.3$ V, SR = 1 kbps, FSK

4. Typical Application Schematic

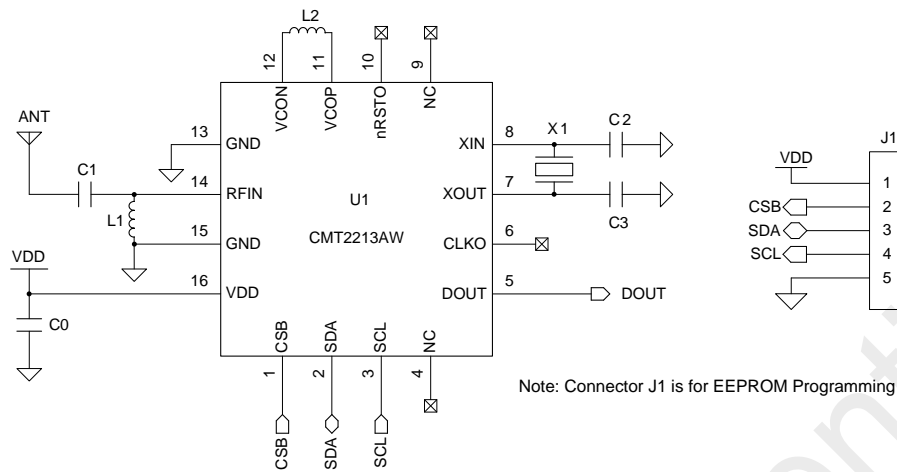

Figure 9. Typical Application Schematic

Notes:

1. Connector J1 is a must for the CMT2213AW EEPROM access during development or manufacture.
2. The general layout guidelines are listed below. For more design details, please refer to “AN107 CMT221x Schematic and PCB Layout Design Guideline”.
 - Use as much continuous ground plane metallization as possible.
 - Use as many grounding vias (especially near to the GND pins) as possible to minimize series parasitic inductance between the ground pour and the GND pins.
 - Avoid using long and/or thin transmission lines to connect the components.
 - Place C0 as close to the CMT2213AW as possible for better filtering.
3. The table below shows the BOM of typical application.

Table 8. BOM of Typical Application

Designator	Descriptions	Value (Match to 50Ω ANT)		Value (Common Used ANT)		Unit	Manufacturer
		315 MHz	433.92 MHz	315 MHz	433.92 MHz		
U1	CMT2213AW, low-cost 300 – 480 MHz (G)FSK/OOK stand-alone RF receiver	-		-		-	CMOSTEK
X1	±20 ppm, SMD32*25 mm, crystal	26		26		MHz	EPSON
L1	±5%, 0603 multi-layer chip inductor	33	27	68	33	nH	Murata LQG18
L2	±5%, 0603 multi-layer chip inductor	33	22	33	22	nH	Murata LQG18
C1	±0.25 pF, 0402 NP0, 50 V	5.6	3.3	4.3	2.7	pF	Murata GRM15
C0	±20%, 0402 X7R, 25 V	0.1		0.1		uF	Murata GRM15
C2, C3	±5%, 0402 NP0, 50 V	27		27		pF	Murata GRM15

5. Functional Descriptions

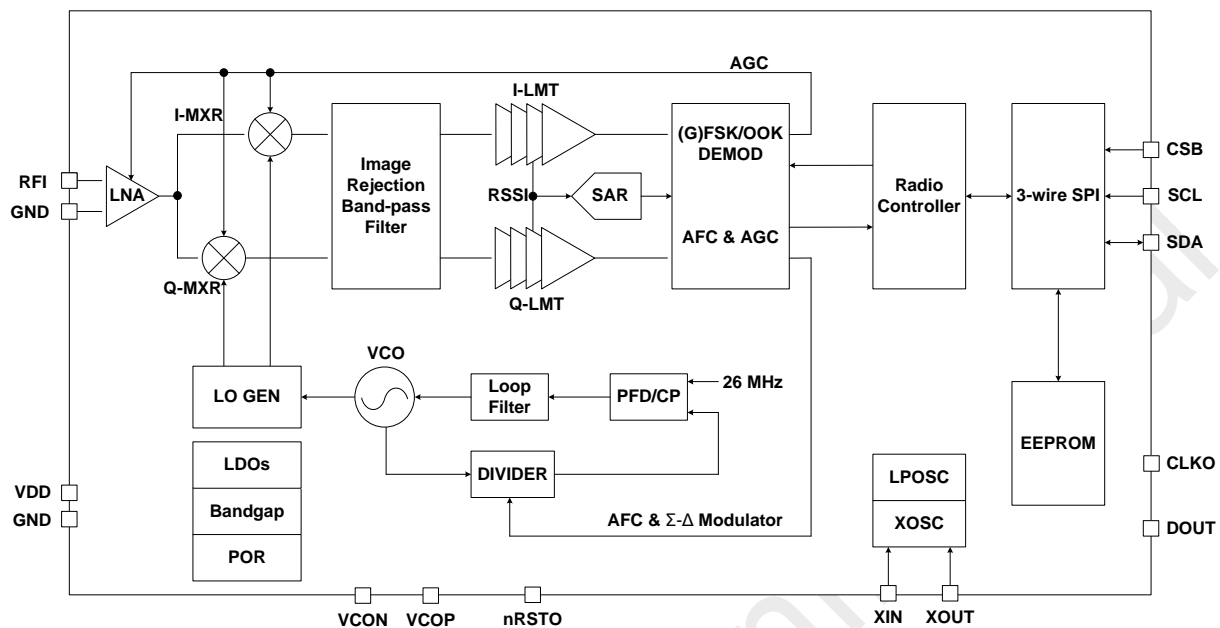

Figure 10. Functional Block Diagram

5.1 Overview

The CMT2213AW is an ultra low power, high performance, low-cost (G)FSK/OOK stand-alone RF receiver for various 300 to 480 MHz wireless applications. It is part of the CMOSTEK NextGenRF™ family, which includes a complete line of transmitters, receivers and transceivers. The chip is based on a fully integrated, low-IF receiver architecture. The low-IF architecture facilitates a very low external component count and does not suffer from powerline - induced interference problems. The synthesizer contains a VCO and a low noise fractional-N PLL with an output frequency resolution of 24.8 Hz. The VCO operates at 2x the Local Oscillator (LO) frequency to reduce spurious emissions. Every analog block is calibrated on each Power-on Reset (POR) to the internal reference voltage. The calibration helps the device to finely work under different temperatures and supply voltages. The baseband filtering and demodulation is done by the digital demodulator. The demodulated signal is output to the external MCU via the DOUT pin. No external MCU control is needed in the applications.

The 3-wire SPI interface is only used for configuring the device. The configuration can be done with the RFPDK and the USB Programmer. The RF Frequency, symbol rate and other product features are all configurable. This saves the cost and simplifies the design, development and manufacture. Alternatively, in stock products of 433.92 MHz is available for immediate demands with no need of EEPROM programming. The CMT2213AW operates from 1.8 to 3.6 V so that it can finely work with most batteries to their useful power limits. The receive current is only 4.3 mA while achieving -111 dBm receiving sensitivity (FSK @ 433.92 MHz F_{RF} , 9.6 kps SR). The CMT2213AW receiver together with the CMT2113AW transmitter enables an ultra low cost RF link.

5.2 Modulation, Frequency Deviation and Symbol Rate

The CMT2213AW supports FSK/GFSK demodulation with the symbol rate from 0.1 to 100 kps, as well as the OOK demodulation with the symbol rate from 0.1 to 40 kps. The supported deviation of the (G)FSK modulation ranges from 1 to 200 kHz. The device continuously covers the frequency range from 300 to 480 MHz, including the license free ISM frequency band around 315 MHz and 433.92 MHz. The internal frequency synthesizer contains a high-purity VCO and a low noise fractional-N

PLL with an output frequency resolution of 24.8 Hz. See the table below for the demodulation, frequency and symbol rate information.

Table 9. Modulation, Frequency and Symbol Rate

Parameter	Value	Unit
Modulation	(G)FSK/OOK	-
Frequency	300 to 480	MHz
Deviation	1 to 200	kHz
Frequency Resolution	24.8	Hz
(G)FSK Symbol Rate	0.1 to 100	ksps
OOK Symbol Rate	0.1 to 40	ksps

5.3 Embedded EEPROM and RFPDK

The RFPDK is a PC application developed to help the user to configure the CMOSTEK NextGenRF™ products in the most intuitive way. The user only needs to connect the USB Programmer between the PC and the device, fill in/select the proper value of each parameter on the RFPDK, and click the “Burn” button to program the configurations into the device. The configurations of the device will then remain unchanged until the next programming. No external MCU control is required in the application program.

The RFPDK also allows the user to save the active configuration into a list by clicking on the “List” button, so that the saved configuration can be directly reloaded from the list in the future. Furthermore, it supports exporting the configuration into a hexadecimal file by clicking on the “Export” button. This file can be used to burn the same configuration into a large amount of devices during the mass production. See the figure below for the accessing of the EEPROM.

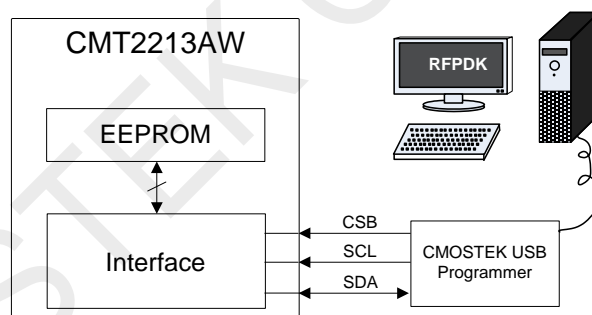

Figure 11. Accessing Embedded EEPROM

For more details of the CMOSTEK USB Programmer and the RFPDK, please refer to “AN103 CMT211xA-221xA One-Way RF Link Development Kits Users Guide”.

5.4 All Configurable Options

Beside the demodulation, frequency and symbol rate, more options can be used to customize the device. The following is a table of all the configurable options. On the RFPDK, the Basic Mode only contains a few options allowing the user to perform easy and fast configurations. The Advanced Mode shows all the options that allow the user to customize the device in a deeper level. The options in “Basic Mode” are a subset of that in the “Advanced Mode”.

Table 10. Configurable Parameters in RFPDK

Category	Parameters	Descriptions	Default	Mode
RF Settings	Frequency	The receive radio frequency, the range is from 300 to 480 MHz, with resolution of 0.001 MHz.	433.920 MHz	Basic Advanced
	Demodulation	The demodulation type, the options are: OOK or (G)FSK demodulation.	(G)FSK	Basic Advanced
	Symbol Rate	The receiver symbol rate, the range is from 0.1 to 100.0 kspss, with resolution of 0.1 kspss.	2.4 kspss	Basic Advanced
	Squelch TH	The threshold of the squelch circuit to suppress the noise, the range is from 0 to 255.	0	Basic Advanced
	Xtal Tol. Rx BW	The sum of the crystal frequency tolerance of the Tx and the Rx, the range is from 0 to ± 300 ppm. And the calculated BW is configured and displayed.	± 20 ppm 100 kHz	Basic Advanced
	Xtal Stabilizing Time	Time for the device to wait for the crystal to get settled after power up. The options are: 78, 155, 310, 620, 1240 or 2480 us.	310 us	Basic Advanced
Operation Settings	Duty-Cycle Mode	Turn on/off the duty-cycle mode, the options are: on or off.	On	Basic Advanced
	Sleep Time	The sleep time in duty-cycle mode, the range is from 3 to 134,152,192 ms.	3 ms	Basic Advanced
	Rx Time	The receive time in duty-cycle mode, the range is from 0.04 to 2,683,043.00 ms.	2,000 ms	Basic Advanced
	Rx Time Ext	The extended receive time in duty-cycle mode, the range is from 0.04 to 2,683,043.00 ms. It is only available when Wake-On Radio is turned on.	200.00 ms	Advanced
	System Clock Output	Turn on/off the system clock output on CLKO, the options are: on or off.	Off	Advanced
	System Clock Frequency	The system clock output frequency, the options are: 13.000, 6.500, 4.333, 3.250, 2.600, 2.167, 1.857, 1.625, 1.444, 1.300, 1.182, 1.083, 1.000, 0.929, 0.867, 0.813, 0.765, 0.722, 0.684, 0.650, 0.619, 0.591, 0.565, 0.542, 0.520, 0.500, 0.481, 0.464, 0.448, 0.433, 0.419 or 0.406 MHz. It is only available when System Clock Output is turned on.	6.500 MHz	Advanced
	Wake-On Radio	Turn on/off the wake-on radio function, the options are: on or off.	Off	Advanced
	Wake-On Condition	The condition to wake on the radio, the option is: Extended by Preamble, or Extended by RSSI. It is only available when Wake-On Radio is turned on.	Extended by Preamble	Advanced
OOK Settings	Demod Method	The OOK demodulation methods, the options are: Peak TH, or Fixed TH	Peak TH	Advanced
	Fixed Demod TH	The threshold value when the Demod Method is "Fixed TH", the minimum input value is the value of Squelch Threshold set on the RFPDK, the maximum value is 255.	60	Advanced
	Peak Drop	Turn on/off the RSSI peak drop function, the options are on, or off.	On	Advanced
	Peak Drop Step	The RSSI peak drop step, the options are: 1, 2, 3, 5, 6, 9, 12 or 15.	1	Advanced

Category	Parameters	Descriptions	Default	Mode
	Peak Drop Rate	The RSSI peak drop rate, the options are: 1 step/4 symbols, 1 step/2 symbols, 1 step /1 symbol, or 1 step/0.5 symbol.	1 step / 4 symbols	Advanced
	AGC	Automatic Gain Control, the options are: on or off.	On	Advanced
(G)FSK Settings	Deviation	The (G)FSK frequency deviation. The minimum value of the deviation is equal to Xtal Tolerance (ppm) x Frequency (MHz) / 0.7. The maximum value of deviation is equal to 220 kHz - Xtal Tolerance (ppm) x Frequency (MHz).	35 kHz	Basic Advanced
	Data Representation	To select whether the frequency "Fo + Fdev" represent data 0 or 1. The options are: 0: F-high 1:F-low, or 0: F-low 1:F-high.	0: F-low 1:F-high	Basic Advanced
	Sync Clock Type	This parameter allows the user to select the method to perform the clock data recovery. The options are: tracing or counting.	Counting	Advanced
	Rising Relative TH	This is the relative threshold to trigger the (G)FSK demodulation. It is measured in terms of RSSI code. The options are: 0, 3, 6, 9, 12, 15, 18, 21, 24, 27, 30, 36, 42, 54, 66, or 90.	21	Advanced
	Falling Relative TH	This is the relative threshold to shut down the (G)FSK demodulation. It is measured in terms of RSSI code. The range is from 0 to 255.	255	Advanced
	AFC	Turn on/off the Automatic Frequency Control function. The options are: On or Off.	On	Advanced
Decode Settings	Preamble	The size of the valid preamble, the options are: 1-byte, 2-byte, 3-byte, or 4-byte.	2-byte	Advanced

5.5 Internal Blocks Description

5.5.1 RF Front-end and AGC

The CMT2213AW features a low-IF receiver. The RF front-end of the receiver consists of a Low Noise Amplifier (LNA), I/Q mixer and a wide-band power detector. Only a low-cost inductor and a capacitor are required for matching the LNA to any common used antennas. The input RF signal induced on the antenna is amplified and down-converted to the IF frequency for further processing.

By means of the wide-band power detector and the attenuation networks built around the LNA, the Automatic Gain Control (AGC) loop regulates the RF front-end's gain to get the best system linearity, selectivity and sensitivity performance, even though the receiver suffers from strong out-of-band interference.

5.5.2 IF Filter

The signals coming from the RF front-end are filtered by the fully integrated 3rd-order band-pass image rejection IF filter which achieves over 35 dB image rejection ratio typically. The IF center frequency is dynamically adjusted to enable the IF filter to locate to the right frequency band, thus the receiver sensitivity and out-of-band interference attenuation performance are kept optimal despite the manufacturing process tolerances. The IF bandwidth is automatically computed according to the three basic system parameters input from the RFPDK: RF frequency, Xtal tolerance, and symbol rate.

5.5.3 RSSI

The subsequent multistage I/Q Log amplifiers enhance the output signal from IF filter before it is fed for demodulation. Receive Signal Strength Indicator (RSSI) generators are included in both Log amplifiers which produce DC voltages that are directly proportional to the input signal level in both of I and Q path. The resulting RSSI is a sum of both these two paths. Extending from the nominal sensitivity level, the RSSI achieves over 66 dB dynamic range.

The CMT2213AW integrates a patented DC-offset cancellation engine. The receiver sensitivity performance benefits a lot from the novel, fast and accurate DC-offset removal implementation.

5.5.4 SAR ADC

The on-chip 8-bit SAR ADC digitalizes the RSSI output. When receiving a FSK or GFSK modulated signal, the digitized RSSI is used to turn on and off the (G)FSK demodulator. When receiving an OOK modulated signal, it is used for OOK demodulation in the digital domain.

5.5.5 Crystal Oscillator

The crystal oscillator is used as the reference clock for the PLL frequency synthesizer and system clock for the digital blocks. A 26 MHz crystal should be used with appropriate loading capacitors. The values of the loading capacitors depend on the total load capacitance C_L specified for the crystal. The total load capacitance seen between the XIN and XOUT pin should equal C_L for the crystal to oscillate at 26 MHz.

$$C_L = \frac{1}{\frac{1}{C_2} + \frac{1}{C_3}} + C_{\text{parasitic}}$$

The parasitic capacitance is constituted by the input capacitance and PCB tray capacitance. The ESR of the crystal should be within the specification in order to ensure a reliable start-up (see Section 1.4 on page 7). An external signal source can easily be used in place of a conventional XTAL and should be connected to the XIN pin. The incoming clock signal is recommended to have a peak-to-peak swing in the range of 300 mV to 700 mV and AC-coupled to the XIN pin.

5.5.6 Frequency Synthesizer

A fractional-N frequency synthesizer is used to generate the LO frequency for the down conversion I/Q mixer. The frequency synthesizer is fully integrated except the VCO tank inductor which enables the ultra low-power receiver system design. Using the 26 MHz reference clock provided by the crystal oscillator or the external clock source, it can generate any receive frequency between 300 to 480 MHz with a frequency resolution of 24.8 Hz.

The VCO always operates at 2x of LO frequency. A high Q (at VCO frequency) tank inductor should be chosen to ensure the VCO oscillates at any conditions meanwhile burns less power and gets better phase noise performance. In addition, properly layout the inductor matters a lot of achieving a good phase noise performance and less spurious emission. The recommended VCO inductors for different LO frequency bands are shown as bellow.

Table 11. VCO Inductor for 315/433.92 MHz Frequency Band

LO Frequency Band (MHz)	315	433.92
VCO Inductor (nH)	33	22

Multiple subsystem calibrations are performed dynamically to ensure the frequency synthesizer operates reliably in any working conditions.

5.5.7 LPOSC

An internal 1 kHz low power oscillator is integrated in the CMT2213AW. It generates a clock to drive the sleep timer to periodically wake the device from sleep state. The Sleep Time can be configured from 3 to 134,152,192 ms (more than 37 hours) when the device works in duty-cycle receive mode. Since the frequency of the LPOSC drifts when the temperature and supply voltage change, it is automatically calibrated during the PUP state, and is periodically calibrated since then. The calibration scheme allows the LPOSC to maintain its frequency tolerance to less than $\pm 1\%$.

5.6 Operation Mode

An option “Duty-Cycle On-Off” on the RFPDK allows the user to determine how the device behaves. The device is able to work in two operation modes, as shown in the figure below.

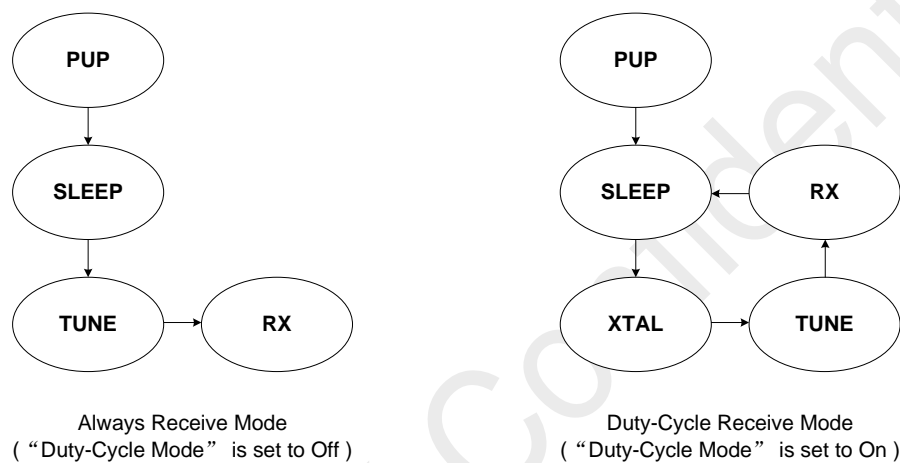

Figure 12. Two different operation modes

Power Up (PUP) State

Once the device is powered up, the device will go through the Power Up (PUP) sequence which includes the task of releasing the Power-On Reset (POR), turning on the crystal and calibrating the internal blocks. The PUP takes about 4 ms to finish in the always receive mode, and about 9.5 ms to finish in the duty-cycle receive mode. This is because that the LPOSC and sleep timer is turned off in the always receive mode, while it must be turned on and calibrated during the PUP in the duty-cycle receive mode. The average current of the PUP sequence is about 0.9 mA.

SLEEP State

In this state, all the internal blocks are powered down except the sleep timer. In Always Receive Mode, the sleep time is fixed at about 3 ms. In Duty-Cycle Receive Mode, the sleep time is defined by the option “Sleep Time” on the RFPDK. The sleep current is about 60 nA in the always receive mode, and about 440 nA (with LPOSC and sleep timer turned on) in the duty-cycle receive mode.

XTAL State

The XTAL state only exists in the duty-cycle receive mode. Once the device wakes up from the SLEEP State, the crystal oscillator restarts to work. The option “XTAL Stabilizing Time” on the RFPDK defines the time for the device to wait for the crystal oscillator to settle. The current consumption in this state is about 520 uA.

TUNE State

The device is tuned to the desired frequency defined by the option “Frequency” on the RFPDK and ready to receive. It usually takes approximately 300 us to complete the tuning sequence. The current consumption in this state is about 2 mA.

RX State

The device receives the incoming signals and outputs the demodulated data from the DOUT pin. In duty-cycle receive mode, the device only stays in the RX State for a certain amount of time, which is defined by the option "Rx Time" on the RFPDK. The current in this state is about 3.8 mA.

5.7 Always Receive Mode

If the duty-cycle receive mode is turned off, the device will go through the Power Up (PUP) sequence, stay in the SLEEP state for about 3 ms, tune the receive frequency, and finally stay in the RX state until the device is powered down. The power up sequence, which takes about 4 ms to finish, includes the task of turning on the crystal and calibrating the internal blocks. The device will continuously receive the incoming RF signals during the RX state and send out the demodulated data on the DOUT pin. The configurable system clock is also output from the CLKO pin if it is enabled in the Advanced Mode on the RFPDK. The figure below shows the timing characteristics and current consumption of the device from the PUP to RX.

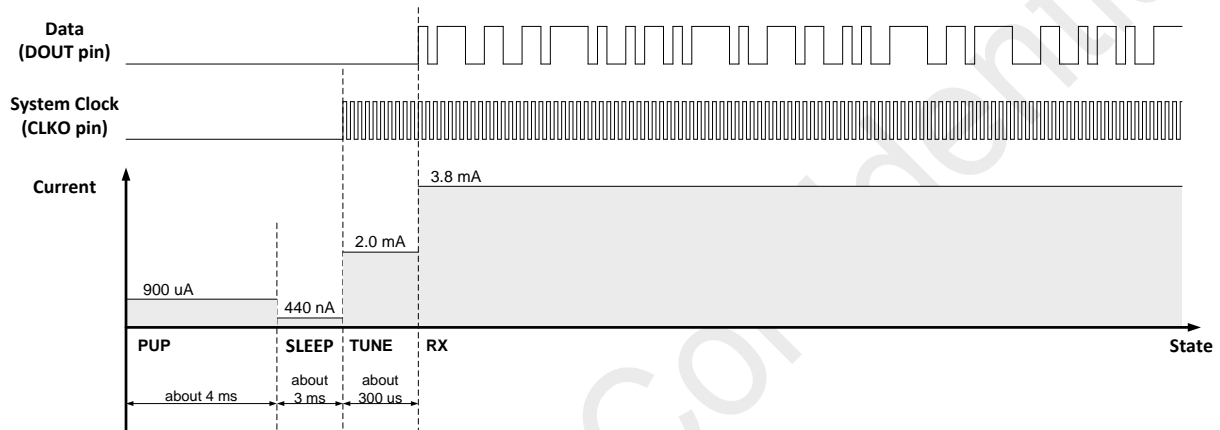

Figure 13. Timing and Current Consumption for Always Receive Mode

5.8 Duty-Cycle Receive Mode

If the duty-cycle mode is turned on, after the PUP the device will automatically repeat the sequence of SLEEP, XTAL, TUNE and RX until the device is powered down. This allows the device to re-tune the synthesizer regularly to adapt to the changeable environment and therefore remain its highest performance. The device will continuously receive any incoming signals during the RX state and send out the demodulated data on the DOUT pin. The configurable system clock output is output from the CLKO pin during the TUNE and RX state. The PUP sequence consumes about 9.5 ms which is longer than the 4 ms in the Always Receive Mode. This is because the LPOSC, which drives the sleep timer, must be calibrated during the PUP.

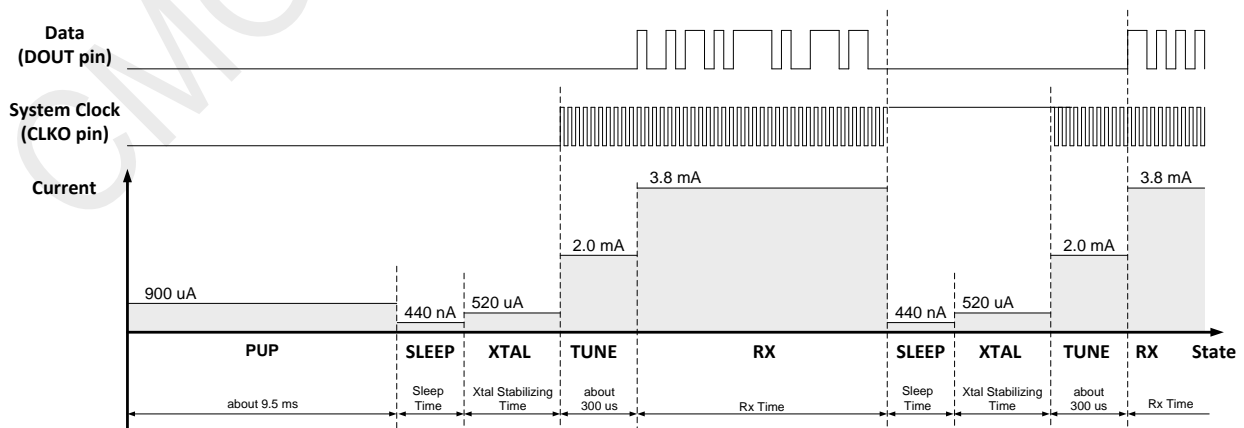

Figure 14. Timing and Current Consumption for Duty-Cycle Receive Mode

It is strongly recommended for the user to turn on the duty-cycle receive mode option. The advantages are listed as below.

- Maintaining the highest performance of the device by regular frequency re-tune.
- Increasing the system stability by regular sleep (resetting most of the blocks).
- Saving power consumptions of both of the Tx and Rx device.

As long as the Sleep Time and Rx Time are properly configured, the transmitted data can always be captured by the device.

5.9 Easy Duty-Cycle Configurations

When the user wants to take the advantage of maintaining the highest system stability and performance, and the power consumption is not the first concern in the system, the Easy Configuration can be used to let the device to work in the duty-cycle mode without complex calculations, the following is a good example.

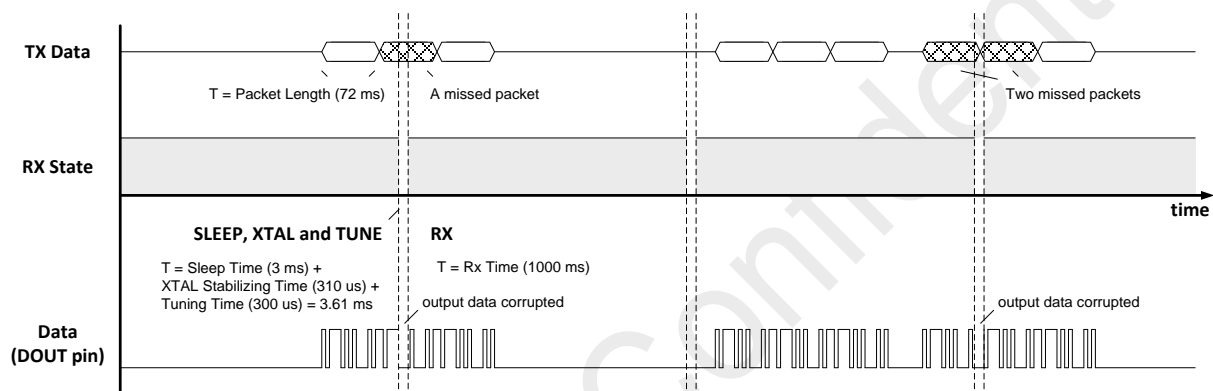

Figure 15. Tx and Rx relationship of Easy Configuration

In this example, the Tx device transmits the data at 1.2 kbps and there are 60 symbols in one data packet. Thus, the packet length is 50 ms. The user can do the following.

- Set the Sleep Time to the minimum value of 3 ms.
- Set the Rx Time to 1 second which is much longer than the packet length.
- Let the Tx device to send out 3 continuous data packets in each transmission.

Because the Sleep Time is very short, the non-receive time is only about 3.61 ms (the sum of the Sleep Time, XTAL stabilizing time and the tuning time), which is much shorter than the packet length of 50 ms. Therefore, this non-receive time period will only have a change to corrupt no more than 2 packets receiving. During the non-receive time period, the DOUT pin will output logic 0.

Because the Rx Time is very long, and 3 continuous data packets are sent in each transmission, there is at least 1 packet that can be completely received by the device and sent out via the DOUT pin with no corruption. The external MCU will only need to observe the DOUT pin status to perform data capturing and further data processing.

If the system power consumption is a sensitive and important factor in the application, the Precise Configuration can be used. Also, based on the duty-cycle receive mode, the "Wake-On Radio" technique allows the device to even save more power. For the precise duty-cycle configurations and the use of wake-on radio, please refer to the "AN108 CMT2213A Configuration Guideline".

5.10 The nRSTO

By default, an active low reset signal is generated by the internal POR and output via the nRSTO pin. It can be used to reset the external MCU if it is required.

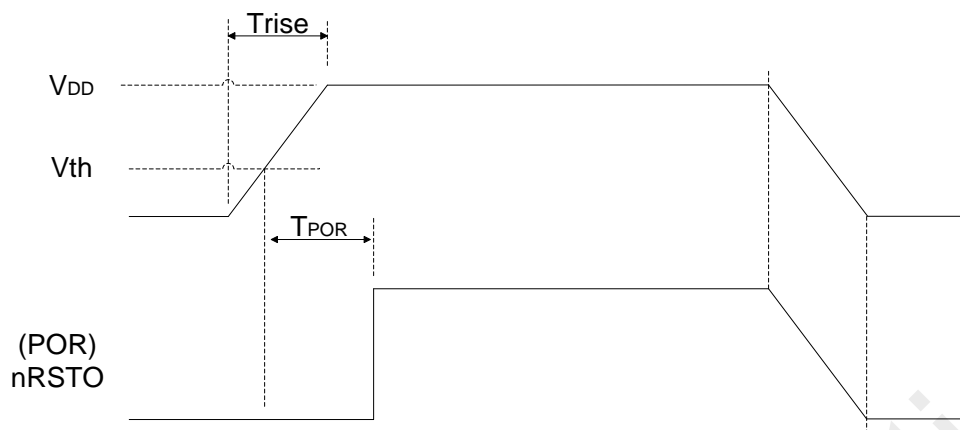

Figure 16. nRSTO Timing Characteristics

On the above figure, T_{rise} is the time taken for the V_{DD} to rise from 0 V to its ultimate stabilized level. After the internal Power-On Reset circuit detects that the V_{DD} has risen over the threshold voltage (V_{th}), it takes the time T_{POR} for the POR to change its state from logical 0 to 1. The V_{th} is about 1.2 V. The value of T_{POR} varies according to the time taken for the V_{DD} to rise from 0 to 3 V, as listed in the table below. When the V_{DD} falls, the $nRSTO$ follows with the V_{DD} simultaneously.

Table 12. T_{POR} Timing Characteristics

T_{RISE} (us)	T_{POR} (us)
3,000	500
1,000	300
300	160
100	100
30	70
10	60

5.11 The CLKO

A clock divided down from the crystal oscillator clock is output via the CLKO pin if the “System Clock Output” is set to “On” on the RFPDK. This clock can be used to drive the external MCU, and is available when the device is in the XTAL, TUNE and RX states. The clock frequency is selected by the option “System Clock Frequency”.

More details of using the CLKO can be referred to the “AN128 CMT2213A Configuration Guideline”.

6. Ordering Information

Table 13. CMT2213AW Ordering Information

Part Number	Descriptions	Package Type	Package Option	Operating Condition	MOQ / Multiple
CMT2213AW-EQR ^[1]	Low-Cost 300 – 480 MHz (G)FSK/OOK Stand-Alone RF Receiver	QFN16 (3x3)	Tape & Reel	1.8 to 3.6 V, -40 to 85 °C	5,000
<p>Note:</p> <p>[1]. “E” stands for extended industrial product grade, which supports the temperature range from -40 to +85 °C. “Q” stands for the package type of QFN16 (3x3). “R” stands for the tape and reel package option, the minimum order quantity (MOQ) for this option is 5,000 pieces. The default frequency for CMT2213AW is 433.920 MHz, for the other settings, please refer to the Table 10 of Page 13.</p>					

Visit www.cmostek.com/products to know more about the product and product line.

Contact sales@cmotek.com or your local sales representatives for more information.

7. Package Outline

The 16-pin QFN 3x3 illustrates the package details for the CMT2213AW. The table below lists the values for the dimensions shown in the illustration.

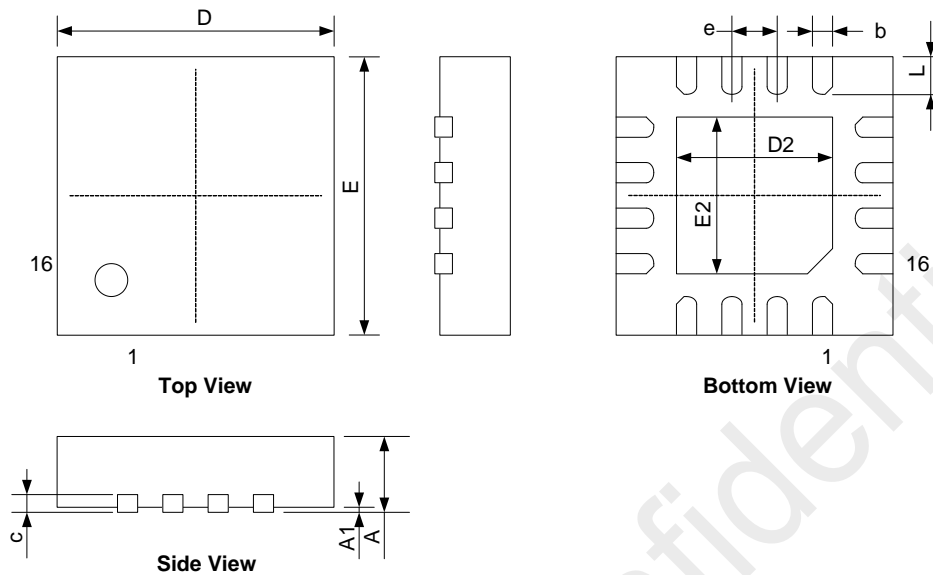

Figure 17. 16-Pin QFN 3x3 Package

Table 14. 16-Pin QFN 3x3 Package Dimensions

Symbol	Size (millimeters)	
	Min	Max
A	0.7	0.8
A1	—	0.05
b	0.18	0.30
c	0.18	0.25
D	2.90	3.10
D2	1.55	1.75
e	0.50 BSC	
E	2.90	3.10
E2	1.55	1.75
L	0.35	0.45

8. Top Marking

8.1 CMT2213AW Top Marking

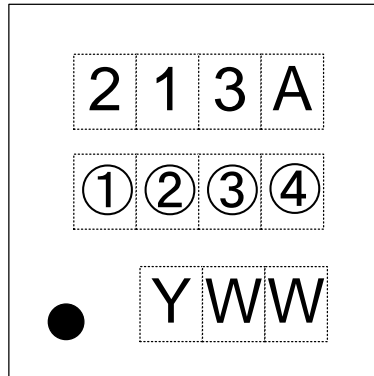

Figure 18. CMT2213AW Top Marking

Table 15. CMT2213AW Top Marking Explanation

Mark Method	Laser
Pin 1 Mark	Circle's diameter = 0.3 mm
Font Size	0.5 mm, right-justified
Line 1 Marking	213A, represents part number CMT2213AW
Line 2 Marking	①②③④ Internal tracking number
Line 3 Marking	Date code assigned by the assembly house. Y represents the last digit of the mold year and WW represents the workweek

9. Other Documentations

Table 16. Other Documentations for CMT2213AW

Brief	Name	Descriptions
AN103	CMT211xA-221xA One-Way RF Link Development Kits Users Guide	User's Guides for CMT211xA and CMT221xA Development Kits, including Evaluation Board and Evaluation Module, CMOSTEK USB Programmer and RFPDK.
AN107	CMT221x Schematic and PCB Layout Design Guideline	Details of CMT2210/13/17/19AW and CMT2210LW PCB schematic and layout design rules, RF matching network and other application layout design related issues.
AN128	CMT2213A Configuration Guideline	Details of configuring CMT2213AW features on the RFPDK.

10. Document Change List

Table 17. Document Change List

Rev. No.	Chapter	Description of Changes	Date
0.8	All	Initial released version	2015-01-23
0.9	5	Update Demodulation option in Table 10,	2015-05-21

CMOSTEK Confidential

11. Contact Information

Hope Microelectronics Co., Ltd

Address: 2/F, Building 3, Pingshan Private Enterprise science and Technology Park, Xili Town, Nanshan District, Shenzhen, China

Tel: +86-755-82973805

Fax: +86-755-82973550

Email: sales@hoperf.com

hoperf@gmail.com

Website: <http://www.hoperf.com>

<http://www.hoperf.cn>

CMOSTEK Confidential

Copyright. CMOSTEK Microelectronics Co., Ltd. All rights are reserved.

The information furnished by CMOSTEK is believed to be accurate and reliable. However, no responsibility is assumed for inaccuracies and specifications within this document are subject to change without notice. The material contained herein is the exclusive property of CMOSTEK and shall not be distributed, reproduced, or disclosed in whole or in part without prior written permission of CMOSTEK. CMOSTEK products are not authorized for use as critical components in life support devices or systems without express written approval of CMOSTEK. The CMOSTEK logo is a registered trademark of CMOSTEK Microelectronics Co., Ltd. All other names are the property of their respective owners.