

300 – 920 MHz OOK Standalone RF Receiver

Features

- Embedded EEPROM
- Frequency Range 300 to 920 MHz
- Data Rate: 0.1 to 40 kbps
- Sensitivity: -113 dBm at 1 kbps, 0.1% BER
- Configurable Receiver Bandwidth: 50 to 330 kHz
- 3-wire SPI Interface for EEPROM Programming
- Stand-Alone, No External MCU Control Required
- Configurable Duty-Cycle Operation Mode
- Rx Active and System Clock Output
- Supply Voltage: 1.8 to 3.6 V
- Low Power Consumption: 3.8 mA
- Low Sleep Current
 - 60 nA when Sleep Timer Off
 - 440 nA when Sleep Timer On
- RoHS Compliant
- 16-pin QFN 3x3 and SOP8 Packages

Descriptions

The CMT221xB/LB device is an ultra-low power, high performance, low-cost OOK stand-alone RF receiver for various 300 to 920 MHz wireless applications. It is part of the CMOSTEK NextGenRF™ family, which includes a complete line of transmitters, receivers and transceivers. An embedded EEPROM allows the frequency, data rate and other features to be programmed into the device using the CMOSTEK USB Programmer and RFPDK. Alternatively, in stock products of 433.92 / 868 MHz is available for immediate demands without the need of EEPROM programming. When the CMT221xB/LB is always on, it consumes only 3.8 mA current while achieving -113 dBm receiving sensitivity. It consumes even less power when working in duty-cycle operation mode via the built-in sleep timer. The CMT221xB/LB receiver together with the CMT221x transmitter enables an ultra-low cost RF link.

Applications

- Low-Cost Consumer Electronics Applications
- Home and Building Automation
- Infrared Receiver Replacements
- Industrial Monitoring and Controls
- Remote Automated Meter Reading
- Remote Lighting Control System
- Wireless Alarm and Security Systems
- Remote Keyless Entry (RKE)

Ordering Information

Part Number	Frequency	Package	MOQ
CMT2217B-EQR	300 - 920 MHz	QFN16(3x3)	5,000 pcs
CMT2210LB-ESR	300 - 480 MHz	SOP8	2,500 pcs
CMT2217LB-ESR	300 - 920 MHz	SOP8	2,500 pcs

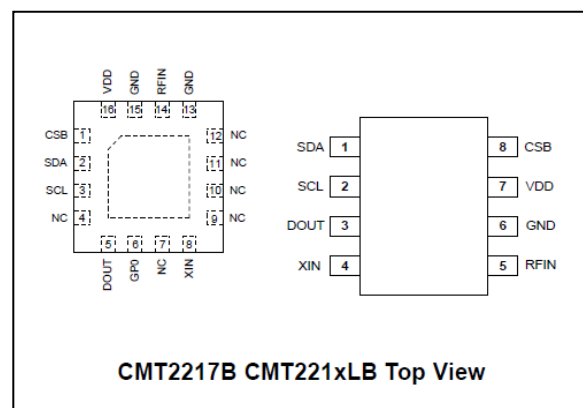
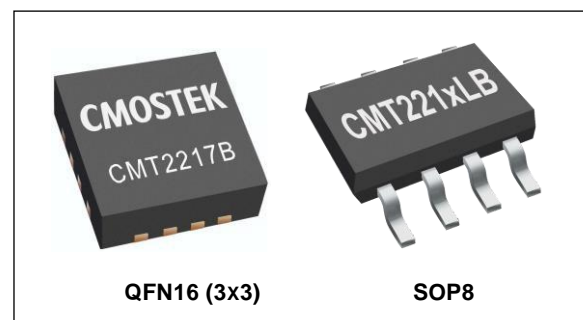

Abbreviations

Abbreviations used in this data sheet are described below

AGC	Automatic Gain Control	PC	Personal Computer
AN	Application Notes	PCB	Printed Circuit Board
BER	Bit Error Rate	PLL	Phase Lock Loop
BOM	Bill of Materials	PN9	Pseudorandom Noise 9
BSC	Basic Spacing between Centers	POR	Power On Reset
BW	Bandwidth	PUP	Power Up
DC	Direct Current	QFN	Quad Flat No-lead
EEPROM	Electrically Erasable Programmable Read-Only Memory	RF	Radio Frequency
ESD	Electro-Static Discharge	RFPDK	RF Products Development Kit
ESR	Equivalent Series Resistance	RoHS	Restriction of Hazardous Substances
Ext	Extended	RSSI	Received Signal Strength Indicator
IF	Intermediate Frequency	Rx	Receiving, Receiver
LNA	Low Noise Amplifier	SAR	Successive Approximation Register
LO	Local Oscillator	SOP	Small Outline Package
LPOSC	Low Power Oscillator	SPI	Serial Port Interface
Max	Maximum	TH	Threshold
MCU	Microcontroller Unit	Tx	Transmission, Transmitter
Min	Minimum	Typ	Typical
MOQ	Minimum Order Quantity	USB	Universal Serial Bus
NP	Not Placed	VCO	Voltage Controlled Oscillator
NP0	Negative-Positive-Zero	WOR	Wake On Radio
NC	Not Connected	XOSC	Crystal Oscillator
OOK	On-Off Keying	XTAL/Xtal	Crystal

Table of Contents

1. Electrical Characteristics	4
1.1 Recommended Operation Conditions.....	4
1.2 Absolute Maximum Ratings	4
1.3 Receiver Specifications.....	5
4. Functional Descriptions.....	11
4.1 Overview	11
4.2 Modulation, Frequency and Data Rate	12
4.3 Embedded EEPROM and RFPDK.....	12
4.4 All Configurable Options	12
4.5 Internal Blocks Description	14
4.6 Operation Mode	15
4.7 Always Rx Mode	16
4.8 Duty-Cycle Receive Mode	17
5. Ordering Information	18
6. Package Outline.....	19
6.1 QFN16 Package	19
6.2 SOP8 Package	20
7. Top Marking	21
7.1 CMT2217B Top Marking.....	21
7.2 CMT2210/17LB Top Marking.....	22
8. Other Documentations	23
9. Document Change List.....	24
10. Contact Information.....	25

1. Electrical Characteristics

$V_{DD} = 3.3\text{ V}$, $T_{OP} = 25\text{ }^{\circ}\text{C}$, $F_{RF} = 433.92\text{ MHz}$, sensitivities are measured in receiving a PN9 sequence and matching to $50\text{ }\Omega$ impedance, with the BER of 0.1%. All measurements are performed using the board CMT221xB/LB-EM, unless otherwise noted.

1.1 Recommended Operation Conditions

Table 1. Recommended Operation Conditions

Parameter	Symbol	Conditions	Min	Typ	Max	Unit
Operation Voltage Supply	V_{DD}		1.8		3.6	V
Operation Temperature	T_{OP}		-40		85	$^{\circ}\text{C}$
Supply Voltage Slew Rate			1			mV/us

1.2 Absolute Maximum Ratings

Table 2. Absolute Maximum Ratings^[1]

Parameter	Symbol	Conditions	Min	Max	Unit
Supply Voltage	V_{DD}		-0.3	3.6	V
Interface Voltage	V_{IN}		-0.3	$V_{DD} + 0.3$	V
Junction Temperature	T_J		-40	125	$^{\circ}\text{C}$
Storage Temperature	T_{STG}		-50	150	$^{\circ}\text{C}$
Soldering Temperature	T_{SDR}	Lasts at least 30 seconds		255	$^{\circ}\text{C}$
ESD Rating ^[2]		Human Body Model (HBM)	-2	2	kV
Latch-up Current			-100	100	mA

Notes:

- [1]. Stresses above those listed as -absolute maximum ratingsll may cause permanent damage to the device. This is a stress rating only and functional operation of the device under these conditions is not implied. Exposure to maximum rating conditions for extended periods may affect device reliability.
- [2]. The CMT221xB/LB is a high-performance RF integrated circuit with the ESD rating over 2 kV HBM. However, handling and assembly of this device should only be done at ESD-protected workstations.

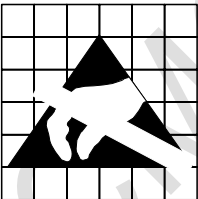

Caution! ESD sensitive device. Precaution should be used when handling the device in order to prevent permanent damage.

1.3 Receiver Specifications

Table 3. Receiver Specifications

Parameter	Symbol	Conditions	Min	Typ	Max	Unit
Frequency Range	F_{RF}	CMT2217B/LB	300		920	MHz
		CMT2210LB	300		480	MHz
Data Rate	DR		0.1		40	kbps
Sensitivity	S_{315}	$F_{RF} = 315$ MHz, DR = 1 kbps, BER = 0.1%		-112		dBm
	$S_{433.92}^{[1]}$	$F_{RF} = 433.92$ MHz, DR = 1 kbps, BER = 0.1%		-113		dBm
	$S_{869}^{[2]}$	$F_{RF} = 868$ MHz, DR = 1 kbps, BER = 0.1%		-103		dBm
	$S_{915}^{[2]}$	$F_{RF} = 915$ MHz, DR = 1 kbps, BER = 0.1%		-103		dBm
Saturation Input Signal Level	P_{LVL}			10		dBm
Working Current	I_{DD}	$F_{RF} = 315$ MHz		3.7		mA
		$F_{RF} = 433.92$ MHz		3.8		mA
		$F_{RF} = 868$ MHz		5.0		mA
		$F_{RF} = 915$ MHz		5.2		mA
Shut Down Current	$I_{SHUTDOWN}$			60		nA
Sleep Current	I_{SLEEP}	When sleep timer is on		440		nA
Frequency Synthesizer Settle Time	T_{LOCK}	From XOSC settled		150		us
Blocking Immunity@ 100kHz BW, 433.92 MHz	BI	DR = 1 kbps, ± 1 MHz offset, CW interference		35		dB
		DR = 1 kbps, ± 2 MHz offset, CW interference		45		dB
		DR = 1 kbps, ± 10 MHz offset, CW interference		65		dB
Image Rejection Ratio	IMR			30		dB
Input 3 rd Order Intercept Point	IIP3	Two tone test at 10 MHz and 20 MHz offset frequency. Maximum system gain settings		-23		dBm
Receiver Bandwidth	BW		50		330	kHz
Receiver Start-up Time	$T_{START-UP}$	From power up to receive, in Always Receive Mode		3		Ms

Note:

[1]. The factory out default configuration of the CMT22xB/LB is optimized for wider data rate (1~5 kbps) range, with the tradeoff of 433.92 MHz sensitivity degraded to -109 dBm. The -113 dBm sensitivity is tested with the configuration generated by the RFPDK.

[2]. The sensitivities for the 868/915 MHz are optimized for better blocking immunity performance, as the frequencies are close to the GSM interference.

1.4 Crystal Oscillator

Table 4. Crystal Oscillator Specifications

Parameter	Symbol	Conditions	Min	Typ	Max	Unit
Crystal Frequency ^[1]	F _{XTAL}	F _{RF} = 315 MHz		26.2736		MHz
		F _{RF} = 433.92 MHz		27.1383		MHz
		F _{RF} = 868 MHz		27.1341		MHz
		F _{RF} = 915 MHz		28.6034		MHz
Crystal Tolerance ^[2]				±20		ppm
Load Capacitance	C _{LOAD}			15		pF
Crystal ESR	R _m				60	Ω
XTAL Startup Time ^[3]	t _{XTAL}			400		us
Notes: [1]. The CMT221xB/LB can directly work with external reference clock input to XIN pin (a coupling capacitor is required) with peak-to-peak amplitude of 0.3 to 0.7 V. [2]. This is the total tolerance including (1) initial tolerance, (2) crystal loading, (3) aging, and (4) temperature dependence. The acceptable crystal tolerance depends on RF frequency and channel spacing/bandwidth. [3]. This parameter is to a large degree crystal dependent.						

1.5 LPOSC

Table 5. LPOSC Specifications

Parameter	Symbol	Conditions	Min	Typ	Max	Unit
Calibrated Frequency ^[1]	F _{LPOSC}			1		kHz
Frequency Accuracy ^[2]		After calibration		1		%
Temperature Coefficient ^[3]				-0.02		%/°C
Supply Voltage Coefficient ^[4]				+0.5		%/V
Initial Calibration Time	t _{LPOSC-CAL}			4		ms
Notes: [1]. The LPOSC is automatically calibrated to the crystal oscillator during the PUP state, and is periodically calibrated since then. [2]. The 1% accuracy is based on the use of 26 MHz XTAL. If the frequency of the selected XTAL is far away from 26 MHz, the accuracy of the LPOSC after calibration might be impacted, and the parameters related to this could be impacted correspondingly. [3]. Frequency drifts when temperature changes after calibration. [4]. Frequency drifts when supply voltage changes after calibration.						

2. Pin Descriptions

2.1 CMT2217B Pin Description

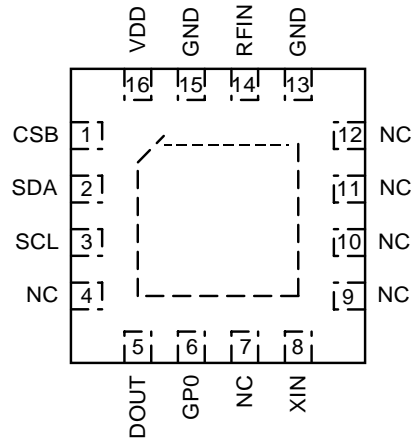

Figure 1. CMT2217B Pin Assignments in QFN16 (3x3) Package

Table 6. CMT2217B Pin Descriptions in QFN16 (3x3) Package

Pin Number	Name	I/O	Descriptions
1	CSB	I	3-wire SPI chip select input for EEPROM programming, internally pulled high
2	SDA	IO	3-wire SPI data input and output for EEPROM programming
3	SCL	I	3-wire SPI clock input for EEPROM programming, internally pulled low
4, 7, 9, 10, 11, 12	NC	NA	Not connected, leave floating
5	DOUT	O	Received data output
6	GP0	O	General purpose output
8	XIN	I	Crystal oscillator input or external reference clock input
13, 15	GND	I	Ground
14	RFIN	I	RF signal input to the LNA
16	VDD	I	Power supply input

2.2 CMT2210/17LB Pin Description

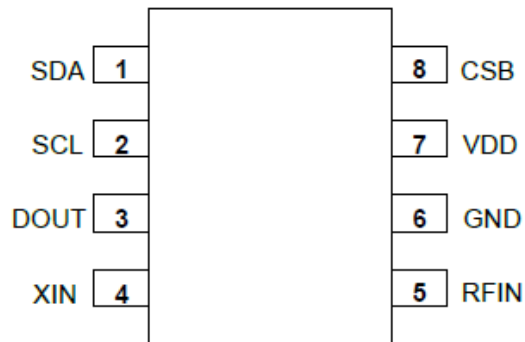

Figure 2. CMT2210/7LB Pin Assignments

Table 7. CMT2210/7LB Pin Descriptions

Pin Number	Name	I/O	Descriptions
1	SDA	IO	3-wire SPI data input and output for EEPROM programming
2	SCL	I	3-wire SPI clock input for EEPROM programming, internally pulled low
3	DOUT	O	Received data output
4	XIN	I	Crystal oscillator input or external reference clock input
5	RFIN	I	RF signal input to the LNA
6	GND	I	Ground
7	VDD	I	Power supply input
8	CSB	I	3-wire SPI chip select input for EEPROM programming, internally pulled high

3. Typical Application Schematic

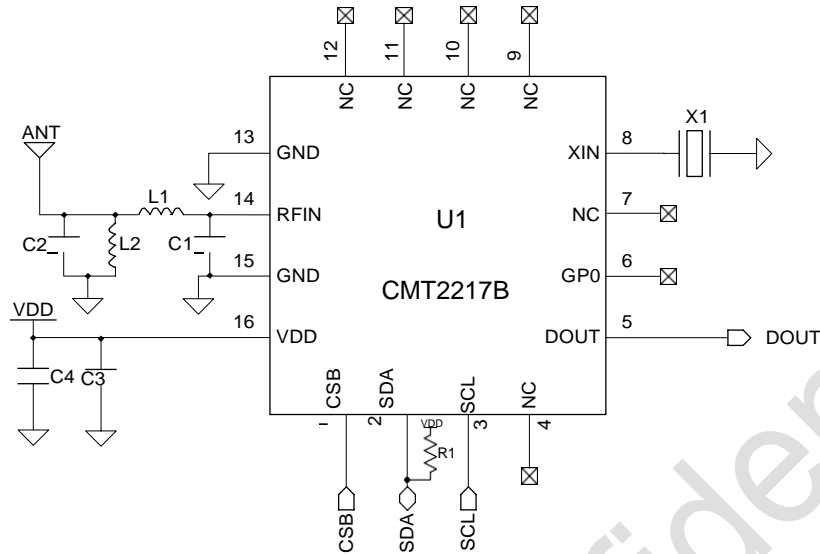

Figure 3. CMT2217B Typical Application Schematic

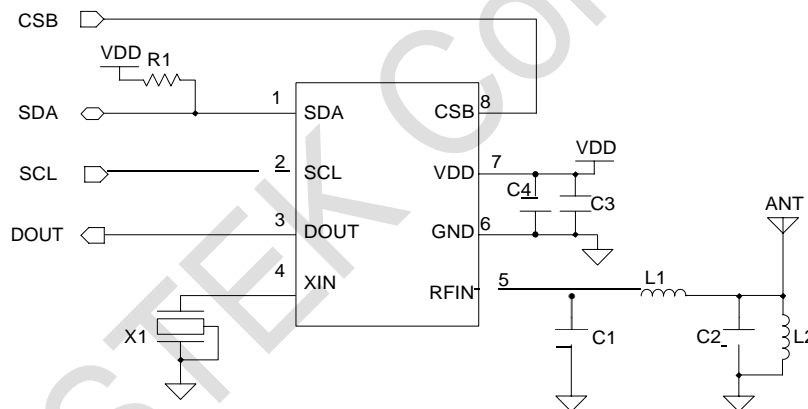

Figure 4. CMT2210/17LB Typical Application Schematic

Notes:

1. Pins CSB, SDA (pull up resistor R1 is required), SCL, VDD and GND should be connected to a connector if the user requires accessing the CMT221xB/LB EEPROM during development or manufacture.
2. The general layout guidelines are listed below. For more design details, please refer to —AN107 CMT221x Schematic and PCB Layout Design Guidelinell.
 - Use as much continuous ground plane metallization as possible.
 - Use as many grounding vias (especially near to the GND pins) as possible to minimize series parasitic inductance between the ground pour and the GND pins.
 - Avoid using long and/or thin transmission lines to connect the components.
 - Place C3 and C4 as close to the CMT221xB/LB as possible for better filtering.
 - Place the crystal as close to the CMT221xB/LB as possible, the metal case of crystal needs grounding.
3. The table below shows the BOM of typical application.

Table 8. BOM of CMT221xB/LB Typical Application

Designator	Descriptions	Value (Matched to $\lambda/4$ ANT)				Unit	Manufacturer
		315 MHz	433.92 MHz	868 MHz	915 MHz		
U1	CMT221xB/LB, 300 – 920 MHz OOK stand-alone RF receiver	-				-	CMOSTEK
X1	± 20 ppm, SMD32*25 mm, crystal, 15 pF Loadcap	26.2736	27.1383	27.1341	28.6034	MHz	EPSON
L1	$\pm 5\%$, 0603 multi-layer chip inductor	68	36	12	10	nH	Murata LQG18
L2	$\pm 5\%$, 0603 multi-layer chip inductor	62	36	8.2	8.2	nH	Murata LQG18
C1	± 0.25 pF, 0402 NP0, 50 V	3	3	NP	NP	pF	Murata GRM15
C2	± 0.25 pF, 0402 NP0, 50 V	12	10	7.5	7.5	pF	Murata GRM15
C3	$\pm 20\%$, 0402 X7R, 25 V	0.1		0.1		uF	Murata GRM15
C4	$\pm 20\%$, 0603 NP0, 50 V	1		1		nF	Murata GRM18
R1	Pull up resistor	10		10		k Ω	

4. Functional Descriptions

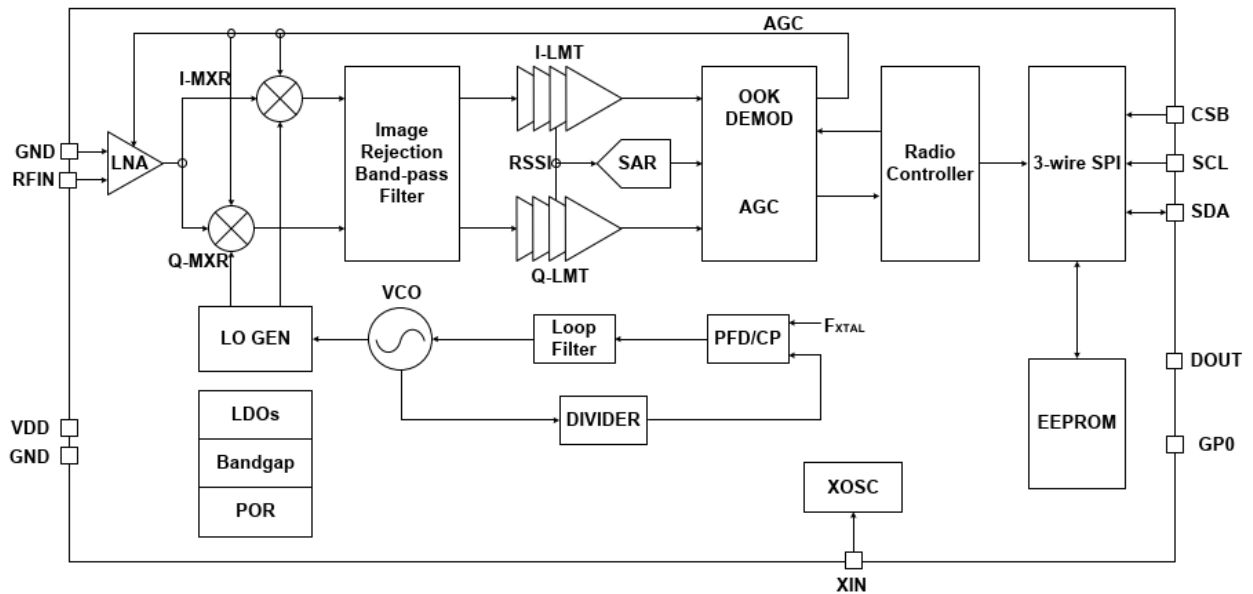

Figure 5. Functional Block Diagram

4.1 Overview

The CMT221xB/LB devices are ultra-low power, high performance, and low cost OOK stand-alone RF receiver for various 300 to 920 MHz wireless applications. It is part of the CMOSTEK NextGenRF™ family, which includes a complete line of transmitters, receivers and transceivers. The chip is based on fully integrated, low-IF receiver architecture. The low-IF architecture facilitates a very low external component count and does not suffer from power line - induced interference problems. The VCO operates at 2x the Local Oscillator (LO) frequency to reduce spurious emissions. Every analog block is calibrated on each Power-on Reset (POR) to the internal reference voltage. The calibration helps the device to finely work under different temperatures and supply voltages. The baseband filtering and demodulation is done by the digital demodulator. The demodulated signal is output to the external MCU via the DOUT pin. No external MCU control is needed in the applications.

The 3-wire SPI interface is only used for configuring the device. The configuration can be done with the RFPDK and the USB Programmer. The data rate and other product features are all configurable. This saves the cost and simplifies the design, development and manufacture. Alternatively, in stock products of 433.92 MHz are available for immediate demands with no need of EEPROM programming. The CMT221xB/LB operates from 1.8 to 3.6 V so that it can finely work with most batteries to their useful power limits. The receive current is only 3.8 mA at 433.92 MHz. The CMT221xB/LB receiver together with the CMT211x transmitter enables an ultra-low cost RF link.

4.2 Modulation, Frequency and Data Rate

The CMT221xB/LB supports OOK demodulation with the data rate from 0.1 to 40 kbps. The CMT2217B/LB covers the frequency range from 300 to 920 MHz, including the license free ISM frequency band around 315 MHz, 433.92 MHz 868 MHz and 915 MHz, while the CMT2210LB covers the frequency range from 300 to 480 MHz. See the table below for the demodulation, frequency and data rate information.

Table 9. Modulation, Frequency and Data Rate

Parameter	Value	Unit
Demodulation	OOK	-
Frequency (CMT2217B/LB)	300 to 920	MHz
Frequency (CMT2210LB)	300 to 480	MHz
Data Rate	0.1 to 40	kbps

4.3 Embedded EEPROM and RFPDK

The RFPDK is a PC application developed to help the user to configure the CMOSTEK NextGenRF™ products in the most intuitional way. The user only needs to connect the USB Programmer between the PC and the device, fill in/select the proper value of each parameter on the RFPDK, and click the -Burn!! button to program the configurations into the device. The configurations of the device will then remain unchanged until the next programming. No external MCU control is required in the application program.

The RFPDK also allows the user to save the active configuration into a list by clicking on the -List!! button, so that the saved configuration can be directly reloaded from the list in the future. Furthermore, it supports exporting the configuration into a hexadecimal file by clicking on the -Export!! button. This file can be used to burn the same configuration into a large amount of devices during the mass production. See the figure below for the accessing of the EEPROM.

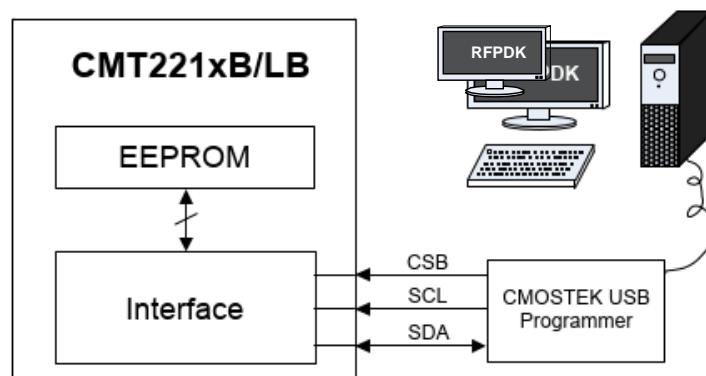

Figure 6. Accessing Embedded EEPROM

For more details of the CMOSTEK USB Programmer and the RFPDK, please refer to -AN103 CMT211xA-221xA One-Way RF Link Development Kits Users Guidell.

4.4 All Configurable Options

Beside the demodulation, frequency and data rate, more options can be used to customize the device. The following is a table of all the configurable options. On the RFPDK, the Basic Mode only contains a few options allowing the user to perform easy and fast configurations. The Advanced Mode shows all the options that allow the user to customize the device in a deeper level.

Table 10. Configurable Parameters in RFPDK

Category	Parameters	Descriptions	Default
RF Settings	Frequency (CMT2210LB)	The receive radio frequency, the range is from 300 to 920 MHz, with resolution of 0.001 MHz. The Xtal Freq. will be calculated based on this parameter.	433.920 MHz
	Frequency (CMT2217B/LB)		868 MHz
	Xtal Freq. (CMT2210LB)	The crystal frequency required for the receive radio frequency.	27.1383 MHz
	Xtal Freq. (CMT2217B/LB)		27.1341 MHz
	Demodulation	The demodulation type, only OOK demodulation is supported in this product.	OOK
	Data Rate	The receiver data rate, the range is from 0.1 to 40 kbps, with resolution of 0.1 kbps.	2.4 kbps
	Tx Freq. Offset	The frequency offset on the Tx side, this is used to calculate the required Rx Bandwidth	± 75 kHz
	Rx Xtal Tol.	Crystal frequency tolerance, this is used to calculate the required Rx Bandwidth	± 20 ppm
	AGC	Automatic Gain Control, the options are: on or off.	On
Operation Settings	Chip Default State	The default state of the chip after power-up, the options are Duty-Cycle and Always Rx.	Always Rx
	Sleep Timer	Turning on and off the sleep timer, when it is turned on, the sleep current is 440 nA in sleep state	off
	Sleep Time	The sleep time in duty-cycle receive mode, the range is from 3 to 134,152,192 ms.	3 ms
	Rx Timer	Turning on and off the Rx timer	off
	Rx Time	The receive time in duty-cycle receive mode, the range is from 0.04 to 2,683,043.00 ms.	2,000 ms
	Rx Time Ext	The extended receive time in duty-cycle receive mode, the range is from 0.04 to 2,683,043.00 ms. It is only available when WOR is on.	200.00 ms
	State after Rx Exit	This defines the state to which the device will switch after the Rx Early Exit. The options are: STBY or TUNE.	STBY
	Wake-On Radio	Turn on/off the wake-on radio function, the options are: on or off.	Off
	Wake-On Condition	The condition to wake on the radio, the options are: <ol style="list-style-type: none"> 1. Extended by RSSI, 2. Extended by Preamble, 3. Extended by Ext-Code 4. Switched to Rx Ext by RSSI, 5. Switched to Rx Ext by Preamble, 6. Switched to Rx Ext by Ext-Code, It is only available when Wake-On Radio is turned on. When the Rx Duty-Cycle is turned on, only type 4, 5 and 6 can be used.	Extended by Preamble
Ext-Code	Extended Code for the WOR, it only available when Wake-On Condition is set to type 3 or 6. The range is from 0 to 255.	0	

Category	Parameters	Descriptions	Default
	Preamble	The size of the valid preamble, the range is from 1 to 4 byte(s). When setting to 0 means detected by the receiver.	1
	System Clock Output (CMT2217B only)	Turn on/off the system clock output on CLKO, the options are: on or off.	Off
	System Clock Frequency (CMT2217B only)	The system clock output frequency, the options are: the F_{XTAL} divided by 2 to by 64. It is only available when System Clock Output is on.	6.785 MHz
	GPO Config (CMT2217B only)	To select the function of the GPO pin, the options are: Rx Active, System Clock, Data Clock or LBD	Rx Active
	GPO Invert (CMT2217B only)	The option to invert the state of the GPO pin	Off
OOK Settings	Bandwidth Options Real BW	The Rx Bandwidth setting, ranging from 50 kHz to 330 kHz, the user can also select Auto-Select to allow the device select the bandwidth based on the RF settings. The real bandwidth will be displayed as Read BW.	Auto-Select
	Auto Squelch Enable	To enable the auto squelch function. When it is enabled, the device will calculate the noise floor level automatically and configure the squelch threshold according to the noise floor level and the Auto Squelch value being set.	Off
	Auto Squelch	This set the squelch level above the calculated noise floor level, when the Auto Squelch function is enabled.	40

4.5 Internal Blocks Description

4.5.1 RF Front-end and AGC

The CMT221xB/LB features a low-IF receiver. The RF front-end of the receiver consists of a Low Noise Amplifier (LNA), I/Q mixer and a wide-band power detector. Only a low-cost inductor and a capacitor are required for matching the LNA to any common used antennas. The input RF signal induced on the antenna is amplified and down-converted to the IF frequency for further processing.

By means of the wide-band power detector and the attenuation networks built around the LNA, the Automatic Gain Control (AGC) loop regulates the RF front-end's gain to get the best system linearity, selectivity and sensitivity performance, even though the receiver suffers from strong out-of-band interference.

4.5.2 IF Filter

The signals coming from the RF front-end are filtered by the fully integrated 3rd-order band-pass image rejection IF filter which achieves over 30 dB image rejection ratio typically. The IF center frequency is dynamically adjusted to enable the IF filter to locate to the right frequency band, thus the receiver sensitivity and out-of-band interference attenuation performance are kept optimal despite the manufacturing process tolerances. The IF bandwidth is automatically computed according to the basic system parameters input from the RFPDK: Tx Freq. Offset, Rx Xtal Tol., and Data Rate.

4.5.3 RSSI

The subsequent multistage I/Q Log amplifiers enhance the output signal from IF filter before it is fed for demodulation. Receive Signal Strength Indicator (RSSI) generators are included in both Log amplifiers which produce DC voltages that are directly proportional to the input signal level in both of I and Q path. The resulting RSSI is a sum of both these two paths. Extending from the nominal sensitivity level, the RSSI achieves over 66 dB dynamic range.

The CMT221xB/LB integrates a patented DC-offset cancellation engine. The receiver sensitivity performance benefits a lot from the novel, fast and accurate DC-offset removal implementation.

4.5.4 SAR ADC

The on-chip 8-bit SAR ADC digitalizes the RSSI for OOK demodulation.

4.5.5 Crystal Oscillator

The CMT221xB/LB uses a 1-pin crystal oscillator circuit with the required crystal load capacitance fully integrated. The recommended specification for the crystal is ± 20 ppm, $ESR (R_m) < 60 \Omega$, with 15 pF load capacitance, the XTAL frequency can be obtained when the desired F_{RF} is input on the RFPDK.

For $F_{RF} = 315$ MHz, $F_{XTAL} = 26.27358$ MHz

For $F_{RF} = 433.92$ MHz, $F_{XTAL} = 27.13827$ MHz

For $F_{RF} = 868$ MHz, $F_{XTAL} = 27.13413$ MHz

For $F_{RF} = 920$ MHz, $F_{XTAL} = 28.60338$ MHz

If the RCLK (reference clock) is available in the system, the user can directly use it to drive the CMT221xB/LB by feeding the clock into the chip via the XIN pin. This further saves the system cost due to the removal of the crystal. A coupling capacitor is required if the RCLK is used. The recommended peak-to-peak amplitude of the RCLK is 0.3 to 0.7 V on the XIN pin.

4.5.6 Frequency Synthesizer

An integer-N frequency synthesizer is used to generate the LO frequency for the down conversion I/Q mixer. The frequency synthesizer is fully integrated. Using the reference clock provided by the crystal oscillator or the external clock source, it can generate any receive frequency between 300 to 920 MHz.

Multiple subsystem calibrations are performed dynamically to ensure the frequency synthesizer operates reliably in any working conditions.

4.5.7 LPOSC

An internal 1 kHz low power oscillator is integrated in the CMT221xB/LB. It generates a clock to drive the sleep timer to periodically wake the device from sleep state. The Sleep Time can be configured from 3 to 134,152,192 ms (more than 37 hours) when the device works in duty-cycle receive mode. Since the frequency of the LPOSC drifts when the temperature and supply voltage change, it is automatically calibrated during the PUP state, and is periodically calibrated since then. The calibration scheme allows the LPOSC to maintain its frequency tolerance to less than $\pm 1\%$.

4.6 Operation Mode

An option -Chip Default Statell on the RFPDK allows the user to determine how the device behaves. The device is able to work in two operation modes, as shown in the figure below.

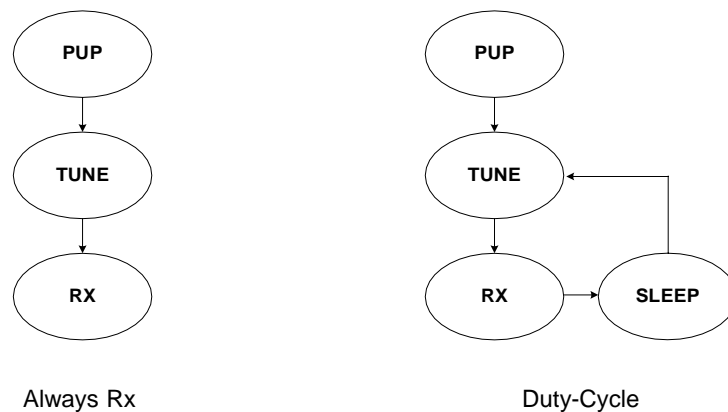

Figure 7. Two different operation modes

Power Up (PUP) State

Once the device is powered up, the device will go through the Power Up (PUP) sequence which includes the task of releasing the Power-On Reset (POR), turning on the crystal and calibrating the internal blocks. The PUP takes about 2.7 ms to finish in the always receive mode, and about 8.2 ms to finish in the duty-cycle receive mode. This is because that the LPOSC and sleep timer is turned off in the always receive mode, while it must be turned on and calibrated during the PUP in the duty-cycle receive mode. The average current of the PUP sequence is about 0.9 mA.

TUNE State

The device is tuned to the desired frequency and ready to receive. It usually takes approximately 300 us to complete the tuning sequence. The current consumption in this state is about 2 mA.

SLEEP State

In this state, all the internal blocks are powered down except the sleep timer. In Always Rx Mode, the device won't go to the SLEEP state. In Duty-Cycle Mode, the sleep time is defined by the option -Sleep Timell on the RFPDK. The sleep current is about 440 nA (with LPOSC and sleep timer turned on) in the Duty-Cycle mode.

RX State

The device receives the incoming signals and outputs the demodulated data from the DOUT pin. In Duty-Cycle mode, the device only stays in the RX State for a certain amount of time, which is defined by the option -Rx Timell on the RFPDK. The current in this state is about 3.8 mA.

4.7 Always Rx Mode

If the Always Rx mode is selected, the device will go through the Power Up (PUP) sequence, tune the receive frequency, and finally stay in the RX state until the device is powered down. The power up sequence, which takes about 2.7 ms to finish, includes the task of turning on the crystal and calibrating the internal blocks. The device will continuously receive the incoming RF signals during the RX state and send out the demodulated data on the DOUT pin. The figure below shows the timing characteristics and current consumption of the device from the PUP to RX.

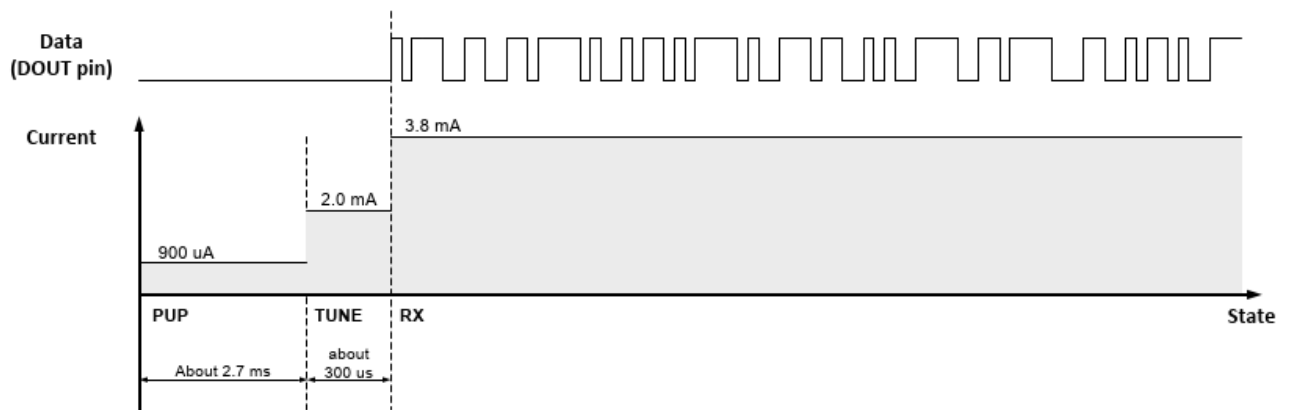

Figure 8. Timing and Current Consumption for Always Rx Mode

4.8 Duty-Cycle Receive Mode

If the duty-cycle mode is selected, after the PUP the device will automatically repeat the sequence of TUNE, RX and SLEEP until the device is powered down. This allows the device to re-tune the synthesizer regularly to adapt to the changeable environment and therefore remain its highest performance. The device will continuously receive any incoming signals during the RX state and send out the demodulated data on the DOUT pin. The configurable system clock output is output from the CLKO pin during the TUNE and RX state. The PUP sequence consumes about 8.2 ms which is longer than the 3 ms in the Always Rx Mode. This is because the LPOSC, which drives the sleep timer, must be calibrated during the PUP.

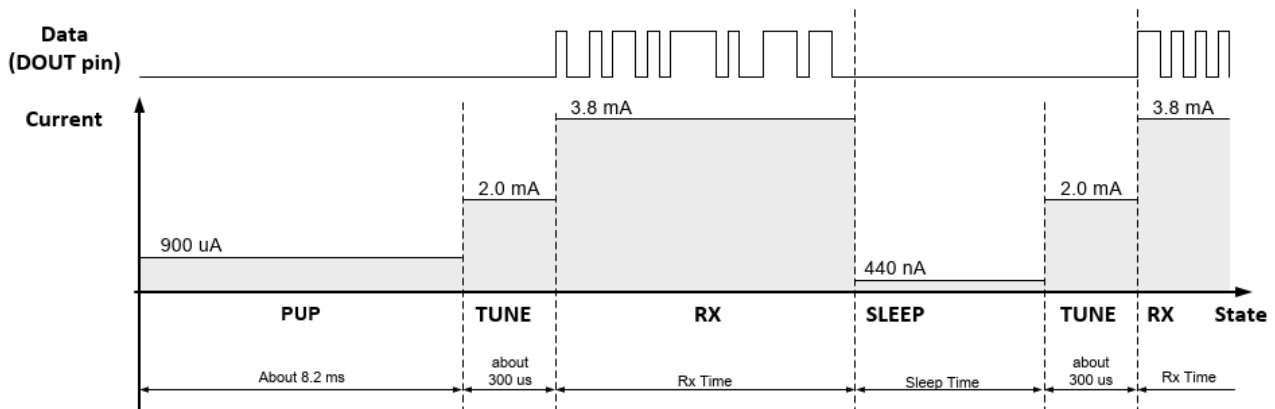

Figure 9. Timing and Current Consumption for Duty-Cycle Receive Mode

It is strongly recommended for the user to turn on the duty-cycle receive mode option. The advantages are:

- Maintaining the highest performance of the device by regular frequency re-tune.
- Increasing the system stability by regular sleep (resetting most of the blocks).
- Saving power consumptions of both of the Tx and Rx device.

As long as the Sleep Time and Rx Time are properly configured, the transmitted data can always be captured by the device.

5. Ordering Information

Table 11. CMT221xB/LB Ordering Information

Part Number	Descriptions	Package Type	Package Option	Operating Condition	MOQ / Multiple
CMT2217B-EQR ^[1]	300 – 920 MHz OOK Stand-Alone RF Receiver	QFN16 (3x3)	Tape & Reel	1.8 to 3.6 V, -40 to 85 °C	5,000
CMT2210LB-ESR ^[1]	300 – 480 MHz OOK Stand-Alone RF Receiver	SOP8	Tape & Reel	1.8 to 3.6 V, -40 to 85 °C	2,500
CMT2217LB-ESR ^[1]	300 – 920 MHz OOK Stand-Alone RF Receiver	SOP8	Tape & Reel	1.8 to 3.6 V, -40 to 85 °C	2,500
<p>Note:</p> <p>[1]. "E" stands for extended industrial product grade, which supports the temperature range from -40 to +85 °C. "Q" stands for the package type of QFN16 (3x3), "-SII" stands for the package type of SOP8. "R" stands for the tape and reel package option, the minimum order quantity (MOQ) is 5,000 pieces for QFN package type, and 2,500 pieces for SOP8 package type The default frequency for CMT221xB/LB is 433.920/868 MHz, covering data rate from 1-5 kbps.</p>					

Visit www.cmostek.com/products to know more about the product and product line.

Contact sales@cmostek.com or your local sales representatives for more information.

6. Package Outline

6.1 QFN16 Package

The 16-pin QFN 3x3 illustrates the package details for the CMT2217B. The table below lists the values for the dimensions shown in the illustration.

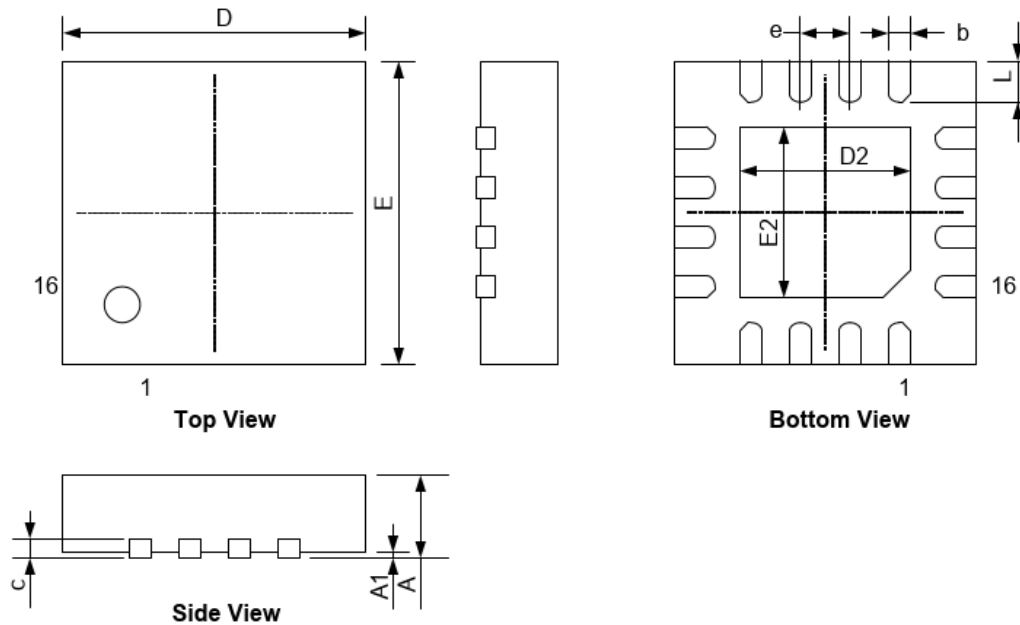

Figure 10. 16-Pin QFN 3x3 Package

Table 12. 16-Pin QFN 3x3 Package Dimensions

Symbol	Size (millimeters)	
	Min	Max
A	0.7	0.8
A1	—	0.05
b	0.18	0.30
c	0.18	0.25
D	2.90	3.10
D2	1.55	1.75
e	0.50 BSC	
E	2.90	3.10
E2	1.55	1.75
L	0.35	0.45

6.2 SOP8 Package

The SOP8 illustrates the package details for the CMT2210/17LB. The table below lists the values for the dimensions shown in the illustration.

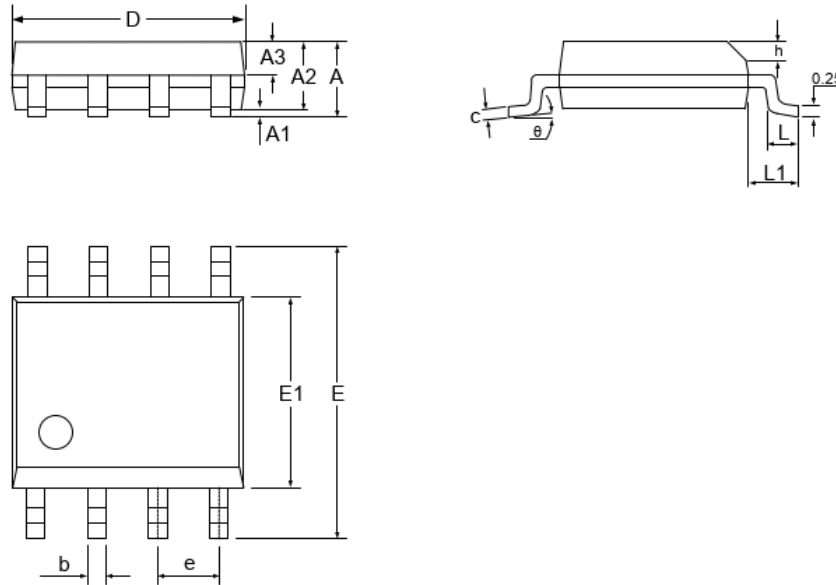

Figure 11. SOP8 Package

Table 13. SOP8 Package Dimensions

Symbol	Size (millimeters)		
	Min	Typ	Max
A	-	-	1.75
A1	0.10	-	0.225
A2	1.30	1.40	1.50
A3	0.60	0.65	0.70
b	0.39	-	0.48
c	0.21	-	0.26
D	4.70	4.90	5.10
E	5.80	6.00	6.20
E1	3.70	3.90	4.10
e	1.27 BSC		
h	0.25	-	0.50
L	0.50	-	0.80
L1	1.05 BSC		
θ	0	-	8°

7. Top Marking

7.1 CMT2217B Top Marking

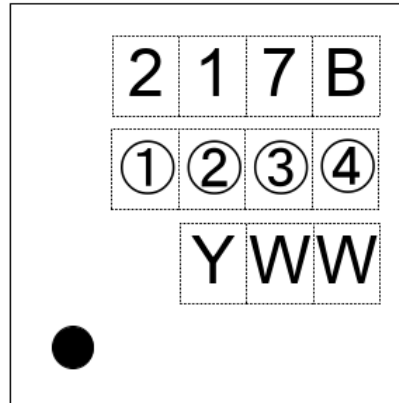

Figure 12. CMT2217B Top Marking in QFN16 Package

Table 14. CMT2217B QFN16 Top Marking Explanation

Mark Method	Laser
Pin 1 Mark	Circle's diameter = 0.2 mm
Font Size	0.5 mm, right-justified
Line 1 Marking	217B, represents part number CMT2217B
Line 2 Marking	①②③④ Internal tracking number
Line 3 Marking	Date code assigned by the assembly house. Y represents the last digit of the mold year and WW represents the workweek

7.2 CMT2210/17LB Top Marking

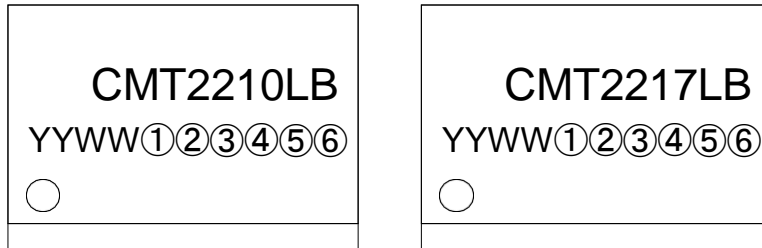

Figure 13. CMT2210/17LB Top Marking in SOP8 Package

Table 15. CMT2210/17LB SOP8 Top Marking Explanation

Mark Method	Laser
Pin 1 Mark	Circle's diameter = 1 mm
Font Height	0.6 mm, right-justified
Font Width	0.4 mm
Line 1 Marking	CMT2210LB, represents part number CMT2210LB CMT2217LB, represents part number CMT2217LB
Line 2 Marking	YYWW is the Date code assigned by the assembly house. YY represents the last two digits of the mold year and WW represents the workweek. ①②③④⑤⑥ is the internal tracking number

8. Other Documentations

Table 16. Other Documentations for CMT221xB/LB

Brief	Name	Descriptions
AN103	CMT211xA-221xA One-Way RF Link Development Kits Users Guide	User's Guides for CMT211xA and CMT221xA Development Kits, including Evaluation Board and Evaluation Module, CMOSTEK USB Programmer and RFPDK.
AN107	CMT221x Schematic and PCB Layout Design Guideline	Details of CMT2210/13/17/19A and CMT2210L PCB schematic and layout design rules, RF matching network and other application layout design related issues.
AN110	CMT221x-5x PCB Schematic and layout Design Guideline	Details of CMT221x and CMT2210Lx PCB schematic and layout design rules, RF matching network and other application layout design related issues, Chinese Version.
AN152	CMT2210B-LB Configuration Guideline	Details of the CMT221xB/LB configurations

9. Document Change List

Table 17. Document Change List

Rev. No.	Chapter	Description of Changes	Date
0.8	All	Initial released version	2017-4-21
0.9	8	Change reference document AN151 to AN152	2020-9-15

CMOSTEK Confidential

10. Contact Information

CMOSTEK Microelectronics Co., Ltd. Shenzhen Branch

Address: 30th floor of 8th Building, C Zone, Vanke Cloud City, Xili Sub-district, Nanshan, Shenzhen, GD, P.R. China

Tel: +86-755-83231427

Post Code: 518055

Sales: sales@cmostek.com

Supports: support@cmostek.com

Website: www.cmostek.com

Copyright. CMOSTEK Microelectronics Co., Ltd. All rights are reserved.

The information furnished by CMOSTEK is believed to be accurate and reliable. However, no responsibility is assumed for inaccuracies and specifications within this document are subject to change without notice. The material contained herein is the exclusive property of CMOSTEK and shall not be distributed, reproduced, or disclosed in whole or in part without prior written permission of CMOSTEK. CMOSTEK products are not authorized for use as critical components in life support devices or systems without express written approval of CMOSTEK. The CMOSTEK logo is a registered trademark of CMOSTEK Microelectronics Co., Ltd. All other names are the property of their respective owners.