

## 1A Lithium Battery Charger CN3066B

### General Description:

The CN3066B is a complete constant-current /constant voltage linear charger for single cell lithium rechargeable battery. The device contains an on-chip power MOSFET and eliminates the need for the external current sense resistor and blocking diode. Furthermore, the CN3066B is specifically designed to work within USB power specifications. Its low external component count makes CN3066B ideally suited for portable applications.

Thermal feedback regulates the charge current to limit the die temperature during high power operation or high ambient temperature. The regulation voltage is internally fixed at 4.2V, it can also be adjusted with an external resistor. The charge current can be programmed externally with a single resistor. When the input supply (wall adapter or USB supply) is removed, the CN3066B automatically enters a low power sleep mode, dropping the battery drain current to less than 3uA. Other features include under-voltage lockout, automatic recharge, battery temperature sensing and charging/termination indicator.

The CN3066B is available in a thermally enhanced 8-pin DFN package.

### Applications:

- Mobile Phones
- Digital Still Cameras
- MP4 Players
- Electronic Dictionary
- Portable Devices
- Variety Of Chargers

### Features:

- Charges Single Cell Li-Ion Batteries Directly from USB Port or AC Adaptor
- Input Voltage Range From 4.35V to 6V
- On-chip Power MOSFET
- No external Blocking Diode or Current Sense Resistors Required
- Constant Charge Voltage 4.2V, and also can be adjustable by an external resistor
- Precharge Conditioning for Reviving Deeply Discharged Cells and Minimizing Heat Dissipation During Initial Stage of Charge
- Continuous Programmable Charge Current Up to 1A
- Constant-Current/Constant-Voltage/Constant-Temp Operation with Thermal Regulation to Maximize Charge Rate Without Risk of Overheating
- Automatic Low-Power Sleep Mode When Input Supply Voltage is Removed
- Status Indication for LEDs or uP Interface
- C/10 Charge Termination
- Automatic Recharge
- Battery Temperature Sensing
- Available in DFN-8 Package
- Pb-free Available

### Pin Assignment

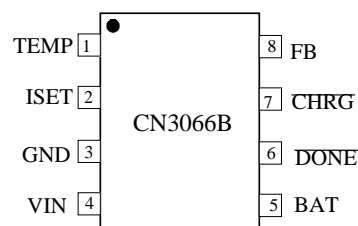

# CONSONANCE

## Typical Application Circuit

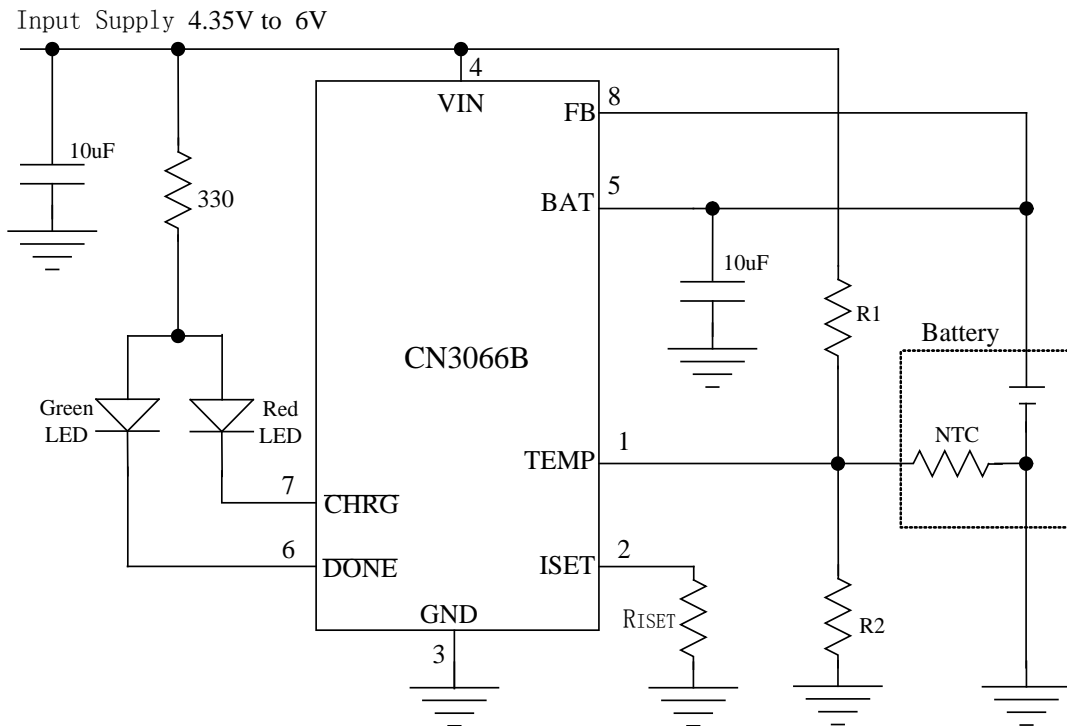

Figure 1 Typical Application Circuit(Constant Voltage Fixed at 4.2V)

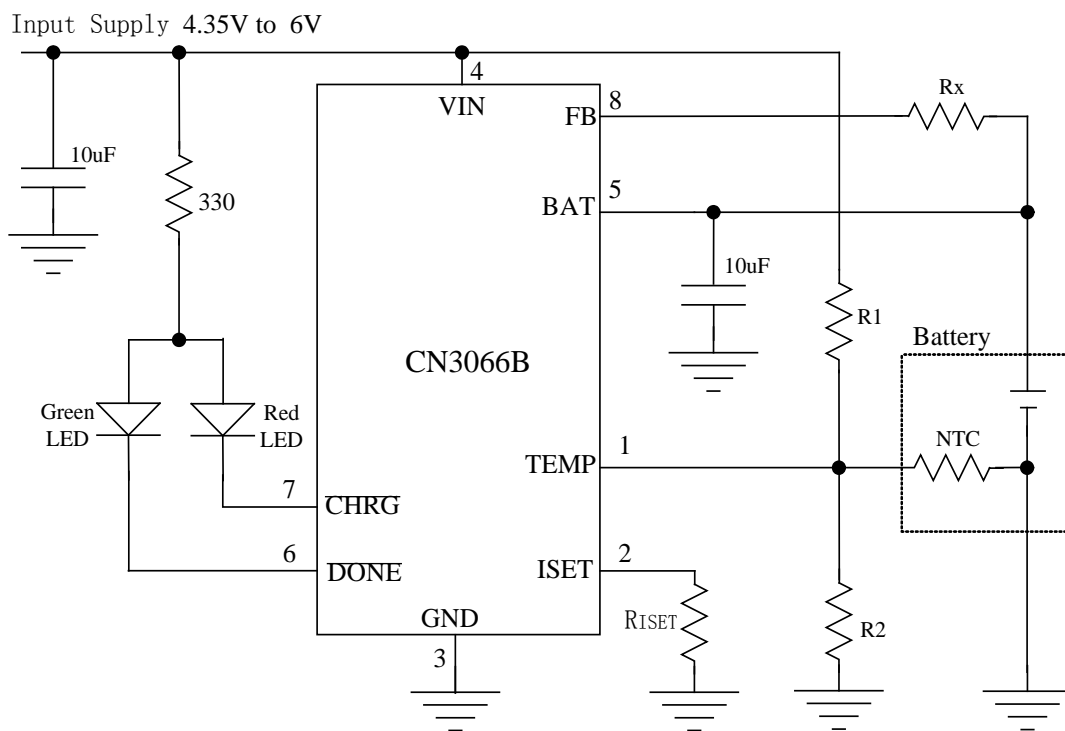

Figure 2 Application Circuit(Adjust Constant Voltage with R<sub>x</sub>)

In Figure 2, the BAT pin's voltage in constant voltage mode is given by the following equation:

$$V_{bat} = 4.2 + 3.04 \times 10^{-6} \times R_x$$

Where,  $V_{bat}$ 's is in volt

$R_x$ 's is in ohm

## Block Diagram

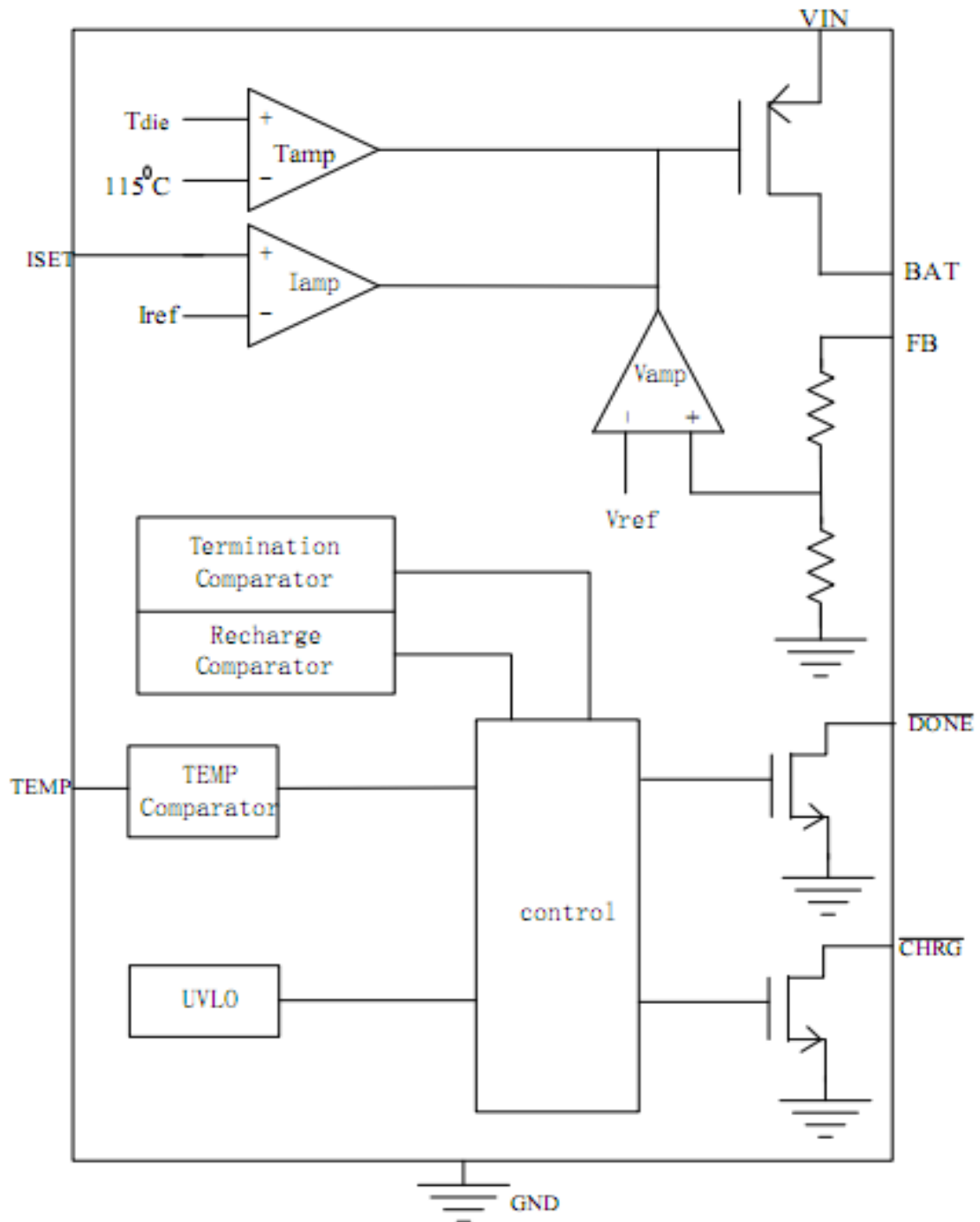

Figure 3 Block Diagram

## Pin Description

Pin No.	Name	Function Description
1	TEMP	<b>Temperature Sense Input.</b> Connecting TEMP pin to NTC thermistor's output in Lithium ion battery pack. If TEMP pin's voltage is below 47% or above 84% of supply voltage $V_{IN}$ for more than 0.15S, this means that battery's temperature is too high or too low, charging is suspended. If TEMP's voltage level is between 47% and 84% of supply voltage for more than 0.15S, battery fault state is released, and charging will resume. The temperature sense function can be disabled by grounding the TEMP pin.
2	ISET	<b>Constant Charge Current Setting and Charge Current Monitor Pin.</b> The charge current is set by connecting a resistor $R_{ISET}$ from this pin to GND. When in precharge mode, the ISET pin's voltage is regulated to 0.2V. When in constant charge current mode, the ISET pin's voltage is regulated to 2V. In all modes during charging, the voltage on ISET pin can be used to measure the charge current as follows: $I_{CH} = (V_{ISET} / R_{ISET}) \times 900$
3	GND	<b>Ground Terminal.</b>
4	VIN	<b>Positive Input Supply Voltage.</b> $V_{IN}$ is the power supply to the internal circuit. When $V_{IN}$ drops to within 40mv of the BAT pin voltage, CN3066B enters low power sleep mode, dropping BAT pin's current to less than 3uA.
5	BAT	<b>Battery Connection Pin.</b> Connect the positive terminal of the battery to BAT pin. BAT pin draws less than 3uA current in chip disable mode or in sleep mode. BAT pin provides charge current to the battery and provides regulation voltage of 4.2V.
6	$\overline{DONE}$	<b>Open-Drain Charge termination Status Output.</b> In charge termination status, $\overline{DONE}$ is pulled low by an internal switch; Otherwise $\overline{DONE}$ pin is in high impedance state.
7	$\overline{CHRG}$	<b>Open Drain Charge Status Output.</b> When the battery is being charged, the $\overline{CHRG}$ pin is pulled low by an internal switch, otherwise $\overline{CHRG}$ pin is in high impedance state.
8	FB	<b>Battery Voltage Kelvin Sense Input.</b> This Pin can Kelvin sense the battery voltage; Also the regulation voltage in constant voltage mode can be adjusted by connecting an external resistor between FB pin and BAT pin.

## Absolute Maximum Ratings

All Terminal Voltage..... -0.3V to 6.5V

BAT Short-Circuit Duration..... Continuous

Storage Temperature..... -65°C to 150°C

Thermal Resistance (DFN-8)..... TBD

Maximum Junction Temperature..... 150°C

Operating Temperature..... -40°C to 85°C

Lead Temperature(Soldering)..... 300°C

*Stresses beyond those listed under 'Absolute Maximum Ratings' may cause permanent damage to the device. These are stress ratings only and functional operation of the device at these or any other conditions above those indicated in the operational sections of the specifications is not implied. Exposure to Absolute Maximum Rating Conditions for extended periods may affect device reliability.*

## Electrical Characteristics

( $V_{IN}=5V$ ,  $T_A=-40^{\circ}C$  to  $85^{\circ}C$ , Typical Values are measured at  $T_A=25^{\circ}C$ , unless otherwise noted)

Parameters	Symbol	Test Conditions	Min	Typ	Max	Unit
Input Supply Voltage	$V_{IN}$		4.35		6	V
Operating Current	$I_{VIN}$	Charge Termination Mode	400	650	950	$\mu A$
Undervoltage Lockout	$V_{uvlo}$	$V_{IN}$ falling		3.7	3.9	V
Undervoltage Lockout Hysteresis	$H_{uvlo}$			0.1		V
Regulation Voltage	$V_{REG}$	Constant Voltage Mode	4.158	4.2	4.242	V
BAT pin Current	$I_{BAT}$	$R_{ISET}=1.8K$ , constant current mode	800	1000	1200	mA
		$R_{ISET}=1.8K$ , $V_{BAT}=2.4V$	50	100	150	
		$V_{IN}=0V$ , sleep mode			3	$\mu A$
<b>Precharge Threshold</b>						
Precharge Threshold	$V_{PRE}$	Voltage at BAT pin rising	2.9	3.0	3.1	V
Precharge Threshold Hysteresis	$H_{PRE}$			0.1		V
<b>Charge Termination Threshold</b>						
Charge Termination Threshold	$V_{term}$	Measure voltage at ISET pin	0.18	0.22	0.26	V
<b>Recharge Threshold</b>						
Recharge Threshold	$V_{RECH}$			$V_{REG}-0.15$		V
<b>Sleep Mode</b>						
Sleep Mode Threshold	$V_{SLP}$	$V_{IN}$ from high to low, measures the voltage ( $V_{IN}-V_{BAT}$ )		20		mv
Sleep mode Release Threshold	$V_{SLPR}$	$V_{IN}$ from low to high, measures the voltage ( $V_{IN}-V_{BAT}$ )		50		mv
<b>ISET Pin</b>						
ISET Pin Voltage	$V_{ISET}$	Precharge mode, $V_{BAT}<3v$		0.2		V
		Constant current mode		2.0		
<b>FB Pin</b>						
FB Input Current 1	$I_{FB1}$	$V_{FB}=3.6V$ , normal working	1.8	3	6	$\mu A$
FB Input Current 1	$I_{FB2}$	$V_{IN}<V_{uvlo}$ 或 $V_{IN}<V_{BAT}$			1	$\mu A$
<b>TEMP PIN</b>						
High Input Threshold	$V_{HIGH}$	The voltage at TEMP increases	81.5	84	86.5	$\% V_{IN}$
Low Input Threshold	$V_{LOW}$	The voltage at TEMP decreases	44.5	47	49.5	$\% V_{IN}$
TEMP input Current		TEMP to $V_{IN}$ or to GND			0.5	$\mu A$
<b>CHRG Pin</b>						
$\overline{CHRG}$ Sink Current	$I_{CHRG}$	$V_{CHRG}=0.3V$ , charge mode		10		mA
$\overline{CHRG}$ Leakage Current		$V_{CHRG}=6V$ , termination mode			1	$\mu A$
<b>DONE Pin</b>						
$\overline{DONE}$ Sink Current	$I_{DONE}$	$V_{DONE}=0.3V$ , charge mode		10		mA
$\overline{DONE}$ Leakage Current		$V_{DONE}=6V$ , termination mode			1	$\mu A$

## Detailed Description

The CN3066B is a linear battery charger designed primarily for charging single cell lithium-ion batteries. Featuring an internal P-channel power MOSFET, the charger uses a constant-current/constant-voltage to charge the batteries. Continuous charge current can be programmed up to 1A with an external resistor. No blocking diode or current sense resistor is required. The open-drain output  $\overline{\text{CHRG}}$  and  $\overline{\text{DONE}}$  indicates the charger's status. The internal thermal regulation circuit reduces the programmed charge current if the die temperature attempts to rise above a preset value of approximate 115°C. This feature protects the CN3066B from excessive temperature, and allows the user to push the limits of the power handling capability of a given circuit board without risk of damaging the CN3066B or the external components. Another benefit of adopting thermal regulation is that charge current can be set according to typical, not worst-case, ambient temperatures for a given application with the assurance that the charger will automatically reduce the current in worst-case conditions. The charge cycle begins when the voltage at the  $V_{\text{IN}}$  pin rises above the UVLO level, a current set resistor is connected from the ISET pin to ground. The  $\overline{\text{CHRG}}$  pin outputs a logic low to indicate that the charge cycle is ongoing. At the beginning of the charge cycle, if the voltage at FB pin is below 3V, the charger is in precharge mode to bring the cell voltage up to a safe level for charging. The charger goes into the fast charge constant current mode once the voltage on the FB pin rises above 3V. In constant current mode, the charge current is set by  $R_{\text{ISET}}$ . When the battery approaches the regulation voltage, the charge current begins to decrease as the CN3066B enters the constant-voltage mode. When the current drops to charge termination threshold, the charge cycle is terminated,  $\overline{\text{DONE}}$  is pulled low by an internal switch and  $\overline{\text{CHRG}}$  pin assumes a high impedance state to indicate that the charge cycle is terminated. The charge termination threshold is 10% of the current in constant current mode. To restart the charge cycle, remove the input voltage and reapply it. The charge cycle can also be automatically restarted if the FB pin voltage falls below the recharge threshold. The on-chip reference voltage, error amplifier and the resistor divider provide regulation voltage with 1% accuracy which can meet the requirement of lithium-ion and lithium polymer batteries. When the input voltage is not present, the charger goes into a sleep mode, dropping battery drain current to less than 3uA. This greatly reduces the current drain on the battery and increases the standby time. The charging profile is shown in the following figure:

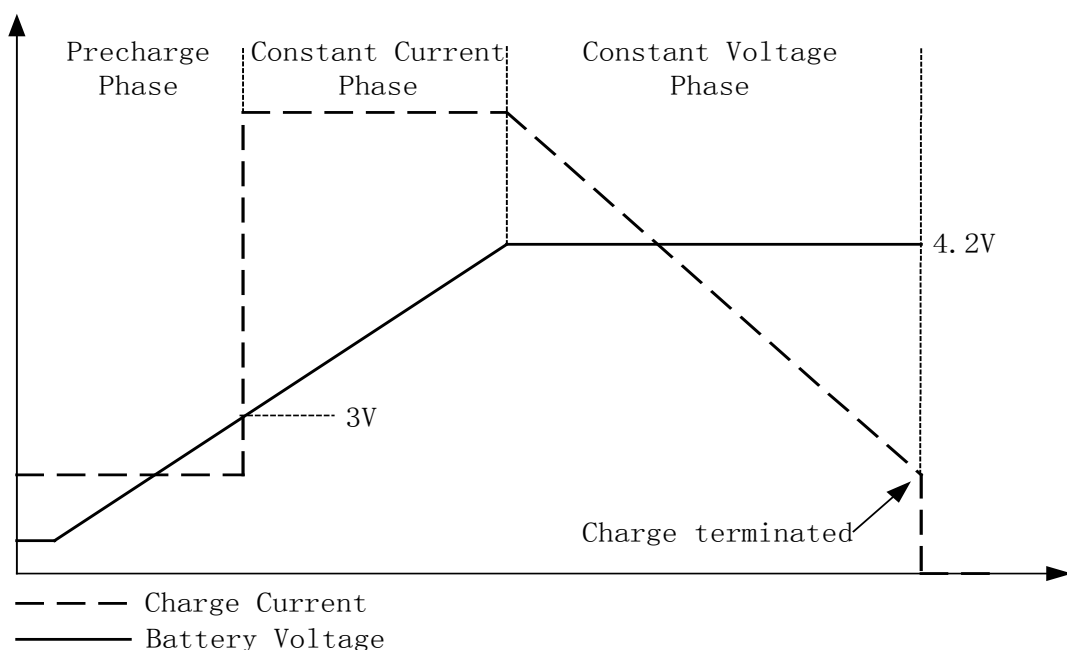

Figure 4 Charging Profile

## Application Information

### Undervoltage Lockout (UVLO)

CN3066B has an internal undervoltage lockout circuit monitors the input voltage and keeps the charger in shutdown mode until  $V_{IN}$  rises above the undervoltage lockout voltage.

### Sleep mode

There is an on-chip sleep comparator in CN3066B. The comparator keeps the charger in sleep mode if  $V_{IN}$  falls below sleep mode threshold ( $V_{BAT}+20\text{mv}$ ). Once in sleep mode, the charger will not come out of sleep mode until  $V_{IN}$  rises 50mv above the battery voltage.

### Precharge mode

At the beginning of a charge cycle, if the battery voltage is below 3V, the charger goes into precharge mode, and the charge current is 10% of fast charge current in constant current mode.

### Battery Voltage Kelvin Detection

There is a battery voltage Kelvin detection of input pin (FB). This pin connects with error amplifier of constant charge through precise resistor divider network on chip. FB pin can be connected to battery's positive electrode directly, and this way can avoid the influence of parasitic resistor for charge between positive electrode and BAT pin. The existence of these parasitic resistors would prolong the charging time or come to constant charging state earlier, or even under-charge of battery. But these problems can be solved by FB pin. If vacant FB pin, CN3066B would always in precharge state, and charging current is 10% of constant current.

### Adjusting the regulation voltage in constant voltage mode

The regulation voltage in constant voltage mode can be adjusted by an external resistor connecting between FB pin and BAT pin as shown in Figure 5:

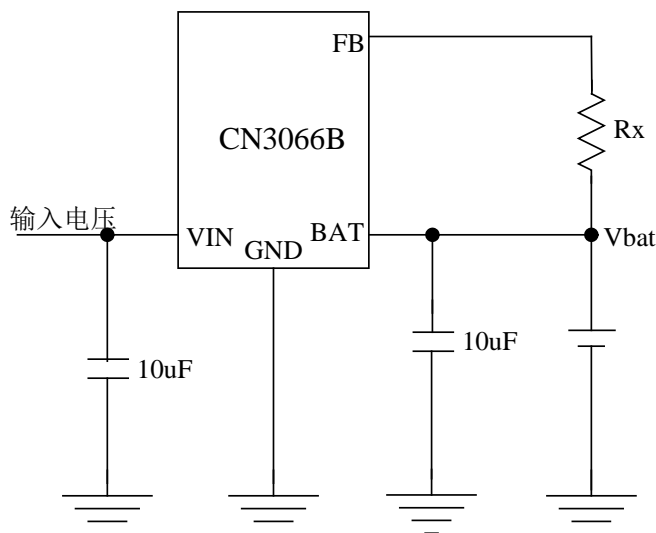

Figure 5 Adjusting Regulation Voltage in Constant Voltage Mode

In Figure 5, the regulation voltage in constant voltage mode will be given by the following equation:

$$V_{bat} = 4.2 + 3.04 \times 10^{-6} \times R_x$$

Where,

$V_{bat}$  is in volt

$R_x$  is in ohm

### Programming Charge Current

The formula for the battery charge current in constant current mode is:

$$I_{CH} = 1800V / R_{ISET}$$

Where:

$I_{CH}$  is the charge current in ampere

$R_{ISET}$  is the total resistance from the ISET pin to ground in ohm

For example, if 500mA charge current is required, calculate:

$$R_{ISET} = 1800V/0.5A = 3.6k\ \Omega$$

For best stability over temperature and time, 1% metal film resistors are recommended. If the charger is in constant-temperature or constant voltage mode, the charge current can be monitored by measuring the ISET pin voltage, and the charge current is calculated as the following equation:

$$I_{CH} = (V_{ISET} / R_{ISET}) \times 900$$

## USB and Wall Adapter Power

Although the CN3066B allows charging from a USB port, a wall adapter can also be used to charge Li-Ion/Li-polymer batteries. Figure 6 shows an example of how to combine wall adapter and USB power inputs. A P-channel MOSFET, M1, is used to prevent back conducting into the USB port when a wall adapter is present and Schottky diode, D1, is used to prevent USB power loss through the 1k  $\Omega$  pull-down resistor.

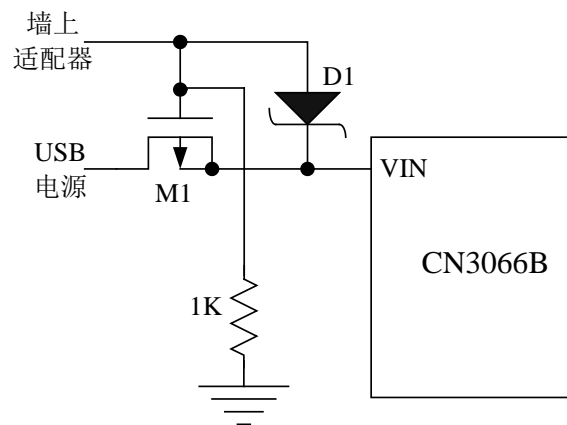

Figure 6 Combining Wall Adapter and USB Power

## Battery Temperature Sense

To prevent the damage caused by the very high or very low temperature done to the battery pack, the CN3066B continuously senses battery pack temperature by measuring the voltage at TEMP pin determined by the voltage divider circuit and the battery's internal NTC thermistor as shown in Figure 1.

The CN3066B compares the voltage at TEMP pin ( $V_{TEMP}$ ) against its internal  $V_{LOW}$  and  $V_{HIGH}$  thresholds to determine if charging is allowed. In CN3066B,  $V_{LOW}$  is fixed at  $(47\% \times V_{IN})$ , while  $V_{HIGH}$  is fixed at  $(84\% \times V_{IN})$ . If  $V_{TEMP} < V_{LOW}$  or  $V_{TEMP} > V_{HIGH}$  for 0.15 seconds, it indicates that the battery temperature is too high or too low and the charge cycle is suspended. When  $V_{TEMP}$  is between  $V_{LOW}$  and  $V_{HIGH}$  for more than 0.15 seconds, the charge cycle resumes.

The battery temperature sense function can be disabled by connecting TEMP pin to GND.

## Selecting R1 and R2

The values of R1 and R2 in the application circuit can be determined according to the assumed temperature monitor range and thermistor's values. The Follows is an example:

Assume temperature monitor range is  $T_L \sim T_H$  ( $T_L < T_H =$  ; the thermistor in battery has negative temperature coefficient (NTC),  $R_{TL}$  is thermistor's resistance at  $T_L$ ,  $R_{TH}$  is the resistance at  $T_H$ , so  $R_{TL} > R_{TH}$ , then at



---

temperature  $T_L$ , the voltage at TEMP pin is:

$$V_{\text{TEMP}L} = \frac{R_2 \parallel R_{TL}}{R_1 + R_2 \parallel R_{TL}} \times V_{\text{IN}}$$

At temperature  $T_H$ , the voltage at TEMP pin is:

$$V_{\text{TEMP}H} = \frac{R_2 \parallel R_{TH}}{R_1 + R_2 \parallel R_{TH}} \times V_{\text{IN}}$$

We know,  $V_{\text{TEMP}L} = V_{\text{HIGH}} = k_2 \times V_{\text{IN}}$  ( $k_2 = 0.84$ )

$$V_{\text{TEMP}H} = V_{\text{LOW}} = k_1 \times V_{\text{IN}} \quad (k_1 = 0.47)$$

Then we can have:

$$R_1 = \frac{R_{TL} R_{TH} (k_2 - k_1)}{(R_{TL} - R_{TH}) k_1 k_2}$$

$$R_2 = \frac{R_{TL} R_{TH} (k_2 - k_1)}{R_{TL} (k_1 - k_1 k_2) - R_{TH} (k_2 - k_1 k_2)}$$

Likewise, for positive temperature coefficient thermistor in battery, we have  $R_{TH} > R_{TL}$  and we can calculate:

$$R_1 = \frac{R_{TL} R_{TH} (k_2 - k_1)}{(R_{TH} - R_{TL}) k_1 k_2}$$

$$R_2 = \frac{R_{TL} R_{TH} (k_2 - k_1)}{R_{TH} (k_1 - k_1 k_2) - R_{TL} (k_2 - k_1 k_2)}$$

We can conclude that temperature monitor range is independent of power supply voltage  $V_{\text{IN}}$  and it only depends on  $R_1$ ,  $R_2$ ,  $R_{TL}$  and  $R_{TH}$ . The values of  $R_{TH}$  and  $R_{TL}$  can be found in related battery handbook or deduced from testing data.

In actual application, if only one terminal temperature is concerned (normally protecting overheating), there is no need to use  $R_2$  but  $R_1$ . In this case it becomes very simple to calculate  $R_1$ .

## Recharge

After a charge cycle has terminated, if the battery voltage drops below the recharge threshold voltage, a new charge cycle will begin automatically.

## Constant-Current/Constant-Voltage/Constant-Temperature

The CN3066B use a unique architecture to charge a battery in a constant-current, constant-voltage, constant temperature fashion as shown in Figure 3. Amplifiers  $I_{amp}$ ,  $V_{amp}$ , and  $T_{amp}$  are used in three separate feedback loops to force the charger into constant-current, constant-voltage, or constant-temperature mode, respectively. In constant current mode the charge current delivered to the battery equal to  $1800V/R_{\text{ISET}}$ . If the power dissipation of the CN3066B results in the junction temperature approaching  $115^\circ\text{C}$ , the amplifier  $T_{amp}$  will begin decreasing the charge current to limit the die temperature to approximately  $115^\circ\text{C}$ . As the battery voltage rises, the CN3066B either returns to constant-current mode or it enters constant voltage mode straight from constant-temperature mode.

## Open-Drain Status Outputs

The CN3066B have 2 open-drain status outputs:  $\overline{\text{CHRG}}$  and  $\overline{\text{DONE}}$ .  $\overline{\text{CHRG}}$  is pulled low when the charger is in charging status, otherwise  $\overline{\text{CHRG}}$  becomes high impedance.  $\overline{\text{DONE}}$  is pulled low if the charger is in charge termination status, otherwise  $\overline{\text{DONE}}$  becomes high impedance.

When the battery is not present, the charger charges the output capacitor to the regulation voltage quickly, then the BAT pin's voltage decays slowly to recharge threshold because of low leakage current at BAT pin, which

results in a 100mv ripple waveform at BAT pin, in the meantime,  $\overline{\text{CHRG}}$  pin outputs a pulse to indicate that the battery's absence. The pulse's frequency is around 10Hz when a 4.7uF output capacitor is used.

The open drain status output that is not used should be tied to ground.

The following table lists the two indicator status and its corresponding charging state. It is supposed that red LED is connected to  $\overline{\text{CHRG}}$  pin and green LED is connected to  $\overline{\text{DONE}}$  pin.

$\overline{\text{CHRG}}$ pin	$\overline{\text{DONE}}$ pin	State Description
Low(the red LED on)	High(the green LED off)	Charging
High(the red LED off)	Low(the green LED on)	Charge termination
Pulse signal	Pulse signal	Battery not connected
High(the red LED off)	High(the green LED off)	There are three possible state: <ul style="list-style-type: none"> <li>● the voltage at the <math>V_{\text{IN}}</math> pin below the UVLO level or</li> <li>● the voltage at the <math>V_{\text{IN}}</math> pin below <math>V_{\text{BAT}}</math> or</li> <li>● abnormal battery's temp</li> </ul>

### $V_{\text{IN}}$ Bypass Capacitor $C_{\text{IN}}$

Many types of capacitors can be used for input bypassing,  $C_{\text{IN}}$  is typically a 4.7uF capacitor.

For the consideration of the bypass capacitor, please refer to the Application Note AN102 from our website [www.consonance-elec.com](http://www.consonance-elec.com)

### Stability

Typically a 4.7uF capacitor from BAT pin to GND is required to stabilize the feedback loop.

In constant current mode, the stability is also affected by the impedance at the ISET pin . With no additional capacitance on the ISET pin, the loop is stable with current set resistors values as high as 50K  $\Omega$  . However, additional capacitance on ISET pin reduces the maximum allowed current set resistor. The pole frequency at ISET pin should be kept above 200KHz. Therefore, if ISET pin is loaded with a capacitance C, the following equation should be used to calculate the maximum resistance value for  $R_{\text{ISET}}$ :

$$R_{\text{ISET}} < 1 / (6.28 \times 2 \times 10^5 \times C)$$

In order to measure average charge current or isolate capacitive load from ISET pin, a simple RC filter can be used on ISET pin as shown in Figure 7.

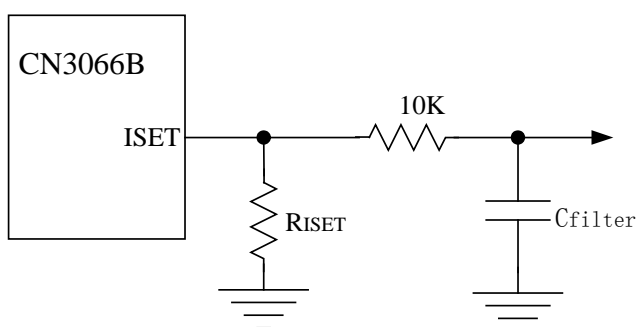

Figure 7 Isolating Capacitive Load on ISET Pin

---

## Board Layout Considerations

1.  $R_{ISET}$  at ISET pin should be as close to CN3066B as possible, also the parasitic capacitance at ISET pin should be kept as small as possible.
2. The capacitance at VIN pin and BAT pin should be as close to CN3066B as possible.
3. During charging, CN3066B's temperature may be high, the NTC thermistor should be placed far enough to CN3066B so that the thermistor can reflect the battery's temperature correctly.
4. It is very important to use a good thermal PC board layout to maximize charging current. The thermal path for the heat generated by the IC is from the die to the copper lead frame through the package lead (especially the ground lead) to the PC board copper, the PC board copper is the heat sink. The footprint copper pads should be as wide as possible and expand out to larger copper areas to spread and dissipate the heat to the surrounding ambient. Feedthrough vias to inner or backside copper layers are also useful in improving the overall thermal performance of the charger. Other heat sources on the board, not related to the charger, must also be considered when designing a PC board layout because they will affect overall temperature rise and the maximum charge current. The ability to deliver maximum charge current under all conditions require that the exposed metal pad on the back side of the CN3066B package be soldered to the PC board ground. Failure to make the thermal contact between the exposed pad on the backside of the package and the copper board will result in larger thermal resistance.

## Package Information

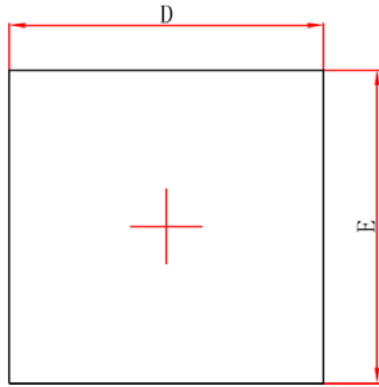

**Top View**

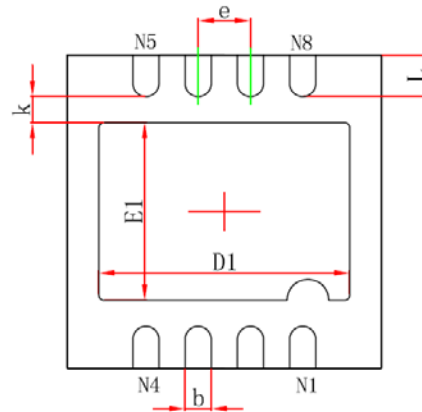

**Bottom View**

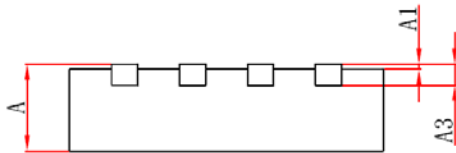

**Side View**

Symbol	Dimensions In Millimeters		Dimensions In Inches	
	Min.	Max.	Min.	Max.
A	0.700/0.800	0.800/0.900	0.028/0.031	0.031/0.035
A1	0.000	0.050	0.000	0.002
A3	0.203REF.		0.008REF.	
D	2.900	3.100	0.114	0.122
E	2.900	3.100	0.114	0.122
D1	2.300	2.500	0.091	0.098
E1	1.600	1.800	0.063	0.071
k	0.200MIN.		0.008MIN.	
b	0.180	0.300	0.007	0.012
e	0.500TYP.		0.020TYP.	
L	0.300	0.500	0.012	0.020

Consonance does not assume any responsibility for use of any circuitry described. Consonance reserves the right to change the circuitry and specifications without notice at any time.