

1A Lithium Battery Charger IC CN3153

General Description:

The CN3153 is a complete constant-current /constant voltage linear charger for single cell lithium rechargeable battery. The device contains an on-chip power MOSFET and eliminates the need for the external current sense resistor and blocking diode. Its low external component count makes CN3153 ideally suited for portable applications.

Thermal feedback regulates the charge current to limit the die temperature during high power operation or high ambient temperature. The regulation voltage is internally fixed at 4.2V, it can also be adjusted with an external resistor. The charge current can be programmed externally with a single resistor. When the input supply is removed, the CN3153 automatically enters a low power sleep mode, dropping the battery drain current to less than 3uA. Other features include under-voltage lockout, automatic recharge and charging/termination indicator.

The CN3153 is available in thermally enhanced 8-pin SOP/PP package.

Applications:

- Electronic Cigarette
- Mobile Phones
- Digital Still Cameras
- MP4 Players
- Electronic Dictionary
- Portable Devices
- Variety Of Chargers

Features:

- On-chip Power MOSFET
- No external Blocking Diode or Current Sense Resistors Required
- Constant Charge Voltage 4.2V, and also can be adjusted by an external resistor
- Precharge Conditioning for Reviving Deeply Discharged Cells and Minimizing Heat Dissipation During Initial Stage of Charge
- Trickle Charge Current can be Selected
- Can be used as a Voltage Source
- Battery Short Circuit Protection
- Programmable Continuous Charge Current Up to 1A
- Constant-Current/Constant-Voltage/Constant-Temperature Operation to Maximize Charge Rate Without Risk of Overheating
- Automatic Low-Power Sleep Mode When Input Supply is Removed
- Status Indication for LEDs or uP Interface
- C/10 Charge Termination
- Automatic Recharge
- Pb-free, rohs compliant, halogen free

Pin Assignment

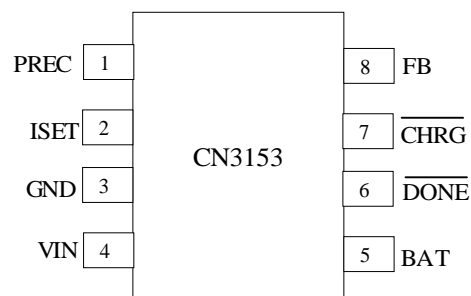

CONSONANCE

Typical Application Circuit

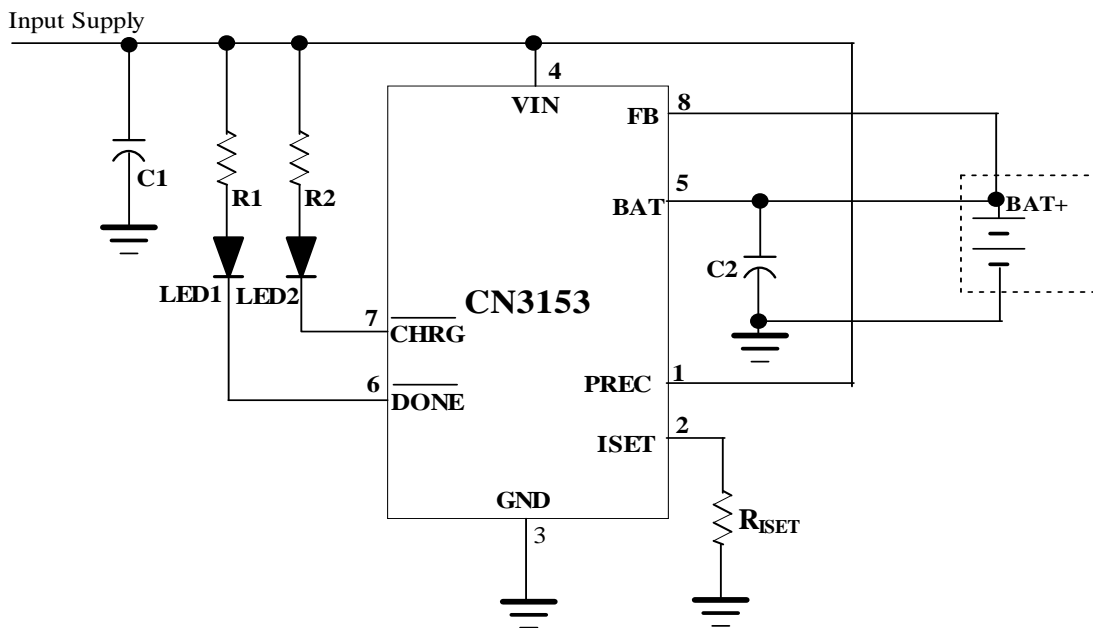

Figure 1 Typical Application Circuit I (Constant Voltage Fixed at 4.2V)

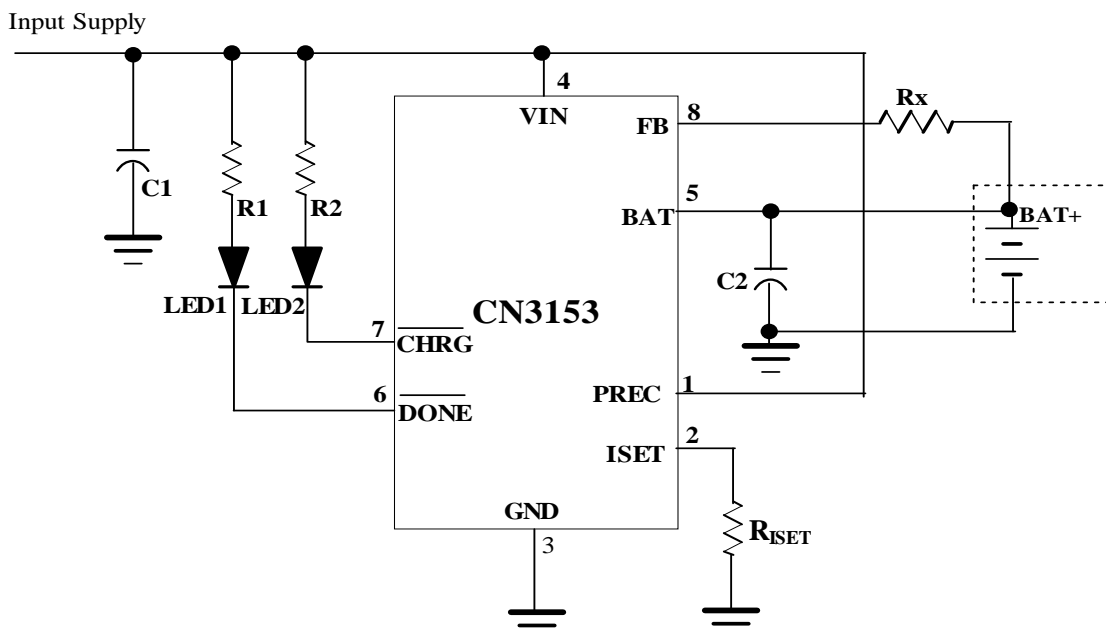

Figure 2 Application Circuit II (Adjust Constant Voltage with R_x)

In Figure 2, the BAT pin's voltage in constant voltage mode is given by the following equation:

$$V_{bat} = 4.2 + 3.61 \times 10^{-6} \times R_x$$

Where, V_{bat} is in volt

R_x is in ohm

CONSONANCE

Note: when an external resistor is used to adjust constant charge voltage, the voltage accuracy may be affected due to the process variation and the temperature difference between the silicon and the environment.

Ordering Information:

| Part No. | Package | Shipping | Operating Temperature Range |
|----------|---------|--------------------------|-----------------------------|
| CN3153 | SOP8/PP | Tape and Reel, 4000/Reel | -40°C to +85°C |

Block Diagram

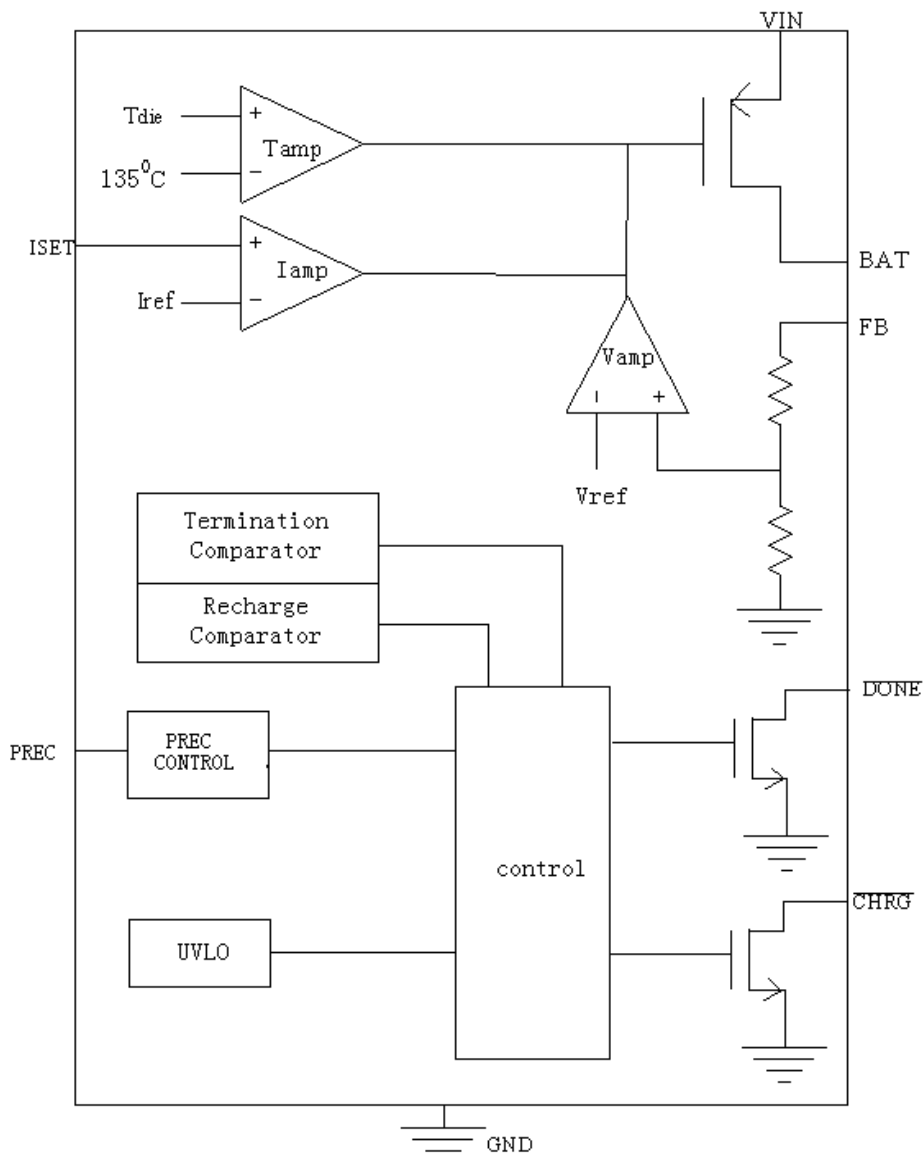

Figure 3 Block Diagram

CONSONANCE

Pin Description

| Pin No. | Name | Function Description |
|---------|-------------------|---|
| 1 | PREC | The Trickle Charge Current setting Pin. If PREC is grounded, the trickle charge current is 10% of the constant charge current; If PREC is connected to VIN, the trickle charge current is equal to constant charge current. |
| 2 | ISET | Constant Charge Current Setting and Charge Current Monitoring Pin. The charge current is set by connecting a resistor R _{ISET} from this pin to GND. When in trickle charge mode, the ISET pin's voltage is regulated to 0.12V. When in constant charge current mode, the ISET pin's voltage is regulated to 1.205V. In all modes during charging, the voltage on ISET pin can be used to measure the charge current as follows: $I_{CH} = (V_{ISET} / R_{ISET}) \times 1011$ |
| 3 | GND | Ground Terminal. |
| 4 | VIN | Positive Terminal of Input Supply Voltage. VIN is the power supply to the internal circuit. When VIN drops to within 10mv of the BAT pin voltage, CN3153 enters low power sleep mode, dropping BAT pin's current to less than 3uA. |
| 5 | BAT | Battery Connection Pin. Connect the positive terminal of the battery to BAT pin. BAT pin draws less than 3uA current in sleep mode. BAT pin provides charge current to the battery. |
| 6 | \overline{DONE} | Charge termination Status Output. Open drain output. In charge termination status, \overline{DONE} is pulled low by an internal switch; Otherwise \overline{DONE} pin is in high impedance state. |
| 7 | \overline{CHRG} | Charge Status Output. When the battery is being charged, the \overline{CHRG} pin is pulled low by an internal switch, otherwise \overline{CHRG} pin is in high impedance state. |
| 8 | FB | Battery Voltage Kelvin Sense Input. This Pin can Kelvin sense the battery voltage; Also the regulation voltage in constant voltage mode can be adjusted by connecting an external resistor between FB and BAT pin. |
| 9 | EP | Exposed PAD of SOP8/PP Package. Should be connected to GND. |

Absolute Maximum Ratings

All Terminal Voltage..... -0.3V to 6.5V

BAT Short-Circuit Duration.....Continuous

Storage Temperature..... -65°C to 150°C

Thermal Resistance (SOP8).....TBD

Maximum Junction Temperature.....150°C

Operating Temperature..... -40°C to 85°C

Lead Temperature(Soldering).....260°C

Stresses beyond those listed under 'Absolute Maximum Ratings' may cause permanent damage to the device. These are stress ratings only and functional operation of the device at these or any other conditions above those indicated in the operational sections of the specifications is not implied. Exposure to Absolute Maximum Rating Conditions for extended periods may affect device reliability.

CONSONANCE

Electrical Characteristics

(VIN=5V, TA=−40°C to 85°C, Typical Values are measured at TA=25°C, unless otherwise noted)

| Parameters | Symbol | Test Conditions | Min | Typ | Max | Unit |
|-------------------------------------|--------|---|-------|-------|-------|-------|
| Input Supply Voltage | VIN | | 3.8 | | 6 | V |
| Operating Current | IVIN | Charge Termination Mode | 300 | 450 | 600 | uA |
| Undervoltage Lockout | Vuvlo | VIN falling | | 3.2 | 3.8 | V |
| Regulation Voltage | VREG | Constant Voltage Mode | 4.158 | 4.2 | 4.242 | V |
| BAT pin Current | IBAT | RISET=1.22K, constant current mode | 850 | 1000 | 1150 | mA |
| | | RISET=1.22K, VBAT = 2.4V, PREC grounding | 75 | 100 | 125 | |
| | | VIN=0V, sleep mode | | | 3 | uA |
| | | Battery short to ground, RISET=1.22K | 70 | 100 | 130 | mA |
| Battery short protection threshold | VSCP | | | 0.75 | | V |
| Precharge Threshold | | | | | | |
| Precharge Threshold | VPRE | Voltage at BAT pin rises | 2.83 | 2.93 | 3.03 | V |
| Precharge Threshold Hysteresis | HPRE | Voltage at BAT pin falls | | 0.24 | | V |
| Charge Termination Threshold | | | | | | |
| Charge Termination Threshold | Vterm | VISET falls, measure voltage at ISET pin | 0.096 | 0.12 | 0.144 | V |
| Recharge Threshold | | | | | | |
| Recharge Threshold | VRECH | VISET rises, measure voltage at ISET pin | 0.215 | 0.24 | 0.265 | V |
| Sleep Mode | | | | | | |
| Sleep Mode Threshold | VSLP | VIN from high to low, measures the voltage (VIN−VBAT) | | 10 | | mv |
| Sleep mode Release Threshold | VSLPR | VIN from low to high, measures the voltage (VIN−VBAT) | | 60 | | mv |
| ISET Pin | | | | | | |
| ISET Pin Voltage | VISET | Precharge mode, VBAT<3V | | 0.12 | | V |
| | | Constant current mode | | 1.205 | | |
| FB Pin | | | | | | |
| FB Input Current 1 | IFB1 | VFVB=3.6V, normal operation | 1.8 | 3 | 6 | uA |
| FB Input Current 1 | IFB2 | VIN<Vuvlo or VIN<VBAT | | | 1 | uA |
| PREC Pin | | | | | | |
| High Input Threshold | VHIGH | | 80 | | | % VIN |
| Low Input Threshold | VLOW | | | | 0.6 | V |
| PREC input Current | | | | | 0.5 | uA |

CONSONANCE

(Continued from last page)

| Parameters | Symbol | Test Conditions | Min | Typ | Max | Unit |
|--|-------------------|--|-----|-----|-----|------|
| $\overline{\text{CHRG}}$ Pin | | | | | | |
| $\overline{\text{CHRG}}$ Sink Current | I_{CHRG} | $V_{\text{CHRG}}=0.3\text{V}$, charge mode | | 10 | | mA |
| $\overline{\text{CHRG}}$ Leakage Current | | $V_{\text{CHRG}}=6\text{V}$, termination mode | | | 1 | uA |
| $\overline{\text{DONE}}$ Pin | | | | | | |
| $\overline{\text{DONE}}$ Sink Current | I_{DONE} | $V_{\text{DONE}}=0.3\text{V}$, charge mode | | 10 | | mA |
| $\overline{\text{DONE}}$ Leakage Current | | $V_{\text{DONE}}=6\text{V}$, termination mode | | | 1 | uA |

Detailed Description

The CN3153 is a linear battery charger designed primarily for charging single cell lithium-ion batteries. Featuring an internal P-channel power MOSFET, the charger uses a constant-current/constant-voltage to charge the batteries. Continuous charge current can be programmed up to 1A with an external resistor. No blocking diode or current sense resistor is required. The open-drain output $\overline{\text{CHRG}}$ and $\overline{\text{DONE}}$ indicates the charger's status. The internal thermal regulation circuit reduces the programmed charge current if the die temperature attempts to rise above a preset value of approximate 135°C. This feature protects the CN3153 from excessive temperature, and allows the user to push the limits of the power handling capability of a given circuit board without risk of damaging the CN3153 or the external components. Another benefit of adopting thermal regulation is that charge current can be set according to typical, not worst-case, ambient temperatures for a given application with the assurance that the charger will automatically reduce the current in worst-case conditions. The charge cycle begins when the voltage at the VIN pin rises above the UVLO level, a current set resistor is connected from the ISET pin to ground. The $\overline{\text{CHRG}}$ pin outputs a logic low to indicate that the charge cycle is ongoing. At the beginning of the charge cycle, if the voltage at FB pin is below 2.93V, the charger is in trickle charge mode. If PREC is grounded, the trickle charge current is 10% of the constant charge current. If PREC is connected to VIN, the trickle charge current is equal to the constant charge current. The charger goes into the fast charge constant current mode once the voltage on the FB pin rises above 2.93V. In constant current mode, the charge current is set by R_{ISET} . When the battery approaches the regulation voltage, the charge current begins to decrease as the CN3153 enters the constant-voltage mode. When the current drops to charge termination threshold, the charge cycle is terminated, $\overline{\text{DONE}}$ is pulled low by an internal switch and $\overline{\text{CHRG}}$ pin assumes a high impedance state to indicate that the charge cycle is terminated. The charge termination threshold is 10% of the current in constant current mode. To restart the charge cycle, remove the input voltage and reapply it. The charge cycle can also be automatically restarted if the ISET pin voltage rises above the recharge threshold. The on-chip reference voltage, error amplifier and the resistor divider provide regulation voltage with 1% accuracy which can meet the requirement of lithium-ion and lithium polymer batteries. When the input voltage is not present, the charger goes into a sleep mode, dropping battery drain current to less than 3uA. This greatly reduces the current drain on the battery and increases the standby time.

CN3153 also integrates a battery short-circuit protection function, when the battery voltage is lower than 0.75V for more than 10ms, CN3153 goes into the battery short circuit protection mode, the current flows out of BAT pin is 10% of the constant charge current. When the battery terminal voltage is greater than the 0.75V for more than 2.5 milliseconds, the CN3153 goes back to normal operation.

The charging profile is shown in figure 4:

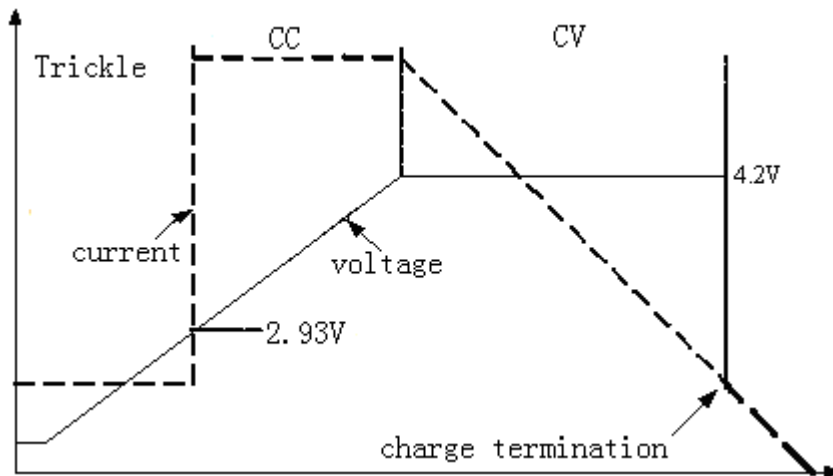

Figure 4 Charging Profile(PREC Grounded)

Application Information

Undervoltage Lockout (UVLO)

CN3153 has an internal undervoltage lockout circuit that monitors the input voltage and keeps the charger in shutdown mode until VIN rises above the undervoltage lockout voltage.

Sleep mode

There is an on-chip sleep comparator in CN3153. The comparator keeps the charger in sleep mode if VIN falls below sleep mode threshold(VBAT+10mv). Once in sleep mode, the charger will not come out of sleep mode until VIN rises 60mv above the battery voltage.

Trickle charge mode

At the beginning of a charge cycle, if the battery voltage is below 2.93V, the charger is in trickle charge mode. If PREC is grounded, the trickle charge current is 10% of the constant charge current. If PREC is connected to VIN, the trickle charge current is equal to the constant charge current.

Battery Voltage Kelvin Detection

There is a battery voltage Kelvin detection of input pin (FB). This pin connects with error amplifier through precise resistor divider network on chip. FB pin can be connected to battery's positive terminal directly, which can avoid the influence of parasitic resistor between positive terminal and BAT pin. The existence of these parasitic resistors would prolong the charging time, or even cause under-charge of battery. These problems can be solved by FB pin. If FB pin is floating or tied to GND, CN3153 would always in trickle charge mode.

Setting Charge Current

The formula for the battery charge current in constant current mode is:

$$I_{CH} = 1218V / R_{ISET}$$

Where: I_{CH} is the charge current in ampere

R_{ISET} is the total resistance from the ISET pin to ground in ohm

For best stability over temperature and time, 1% metal film resistors are recommended. If the charger is in constant-temperature or constant voltage mode, the charge current can be monitored by measuring the ISET pin voltage, and the charge current is calculated as the following equation:

$$I_{CH} = (V_{ISET} / R_{ISET}) \times 1011$$

Adjusting the regulation voltage in constant voltage mode

The regulation voltage in constant voltage mode can be adjusted by an external resistor connecting between FB

CONSONANCE

pin and BAT pin as shown in Figure 5:

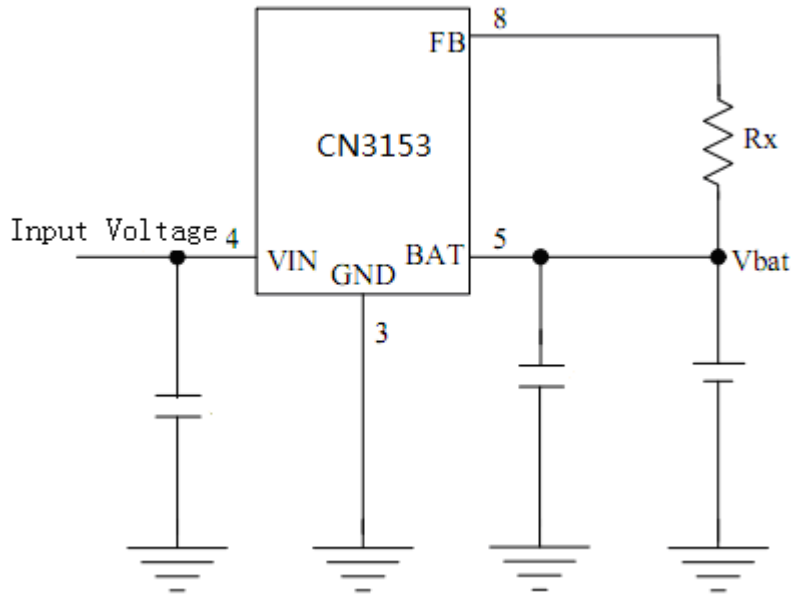

Figure 5 Adjust Regulation Voltage in Constant Voltage Mode

In Figure 5, the regulation voltage in constant voltage mode will be given by the following equation:

$$V_{bat} = 4.2 + 3.61 \times 10^{-6} \times R_x$$

Where, V_{bat} is in volt,

R_x is in ohm

About Typical Application Circuit

The detailed description on the components in typical application circuit of Figure 1 and Figure 2:

| No. | Symbol | Description |
|-----|------------|---|
| 1 | R1 | Resistors for LED current limit. |
| 2 | R2 | |
| 3 | R_{ISET} | The resistor to set constant charge current, the charge current is determined by: $I_{CH} = 1218V / R_{ISET}$ |
| 4 | R_x | The resistor to adjust the constant charge voltage. The regulation voltage in constant charge voltage mode is: $V_{bat} = 4.2 + 3.61 \times 10^{-6} \times R_x$ |
| 5 | C1 | Many types of capacitors can be used for the bypassing capacitor, Generally, a 1uF ceramic capacitor, placed in close proximity to VIN and GND pins, works well. In some applications depending on the power supply characteristics and cable length, it may be necessary to increase the capacitor's value. For the consideration of the bypass capacitor, please refer to the Application Note AN102 from our website. |
| 6 | C2 | Output capacitor, 4.7uF to 10uF. |
| 7 | LED1 | LED indicator for charge termination. |
| 8 | LED2 | LED indicator for charge status. |

Charge Termination

In constant voltage mode, when the charging current decreases to 10% of the constant current, CN3153 will enter into termination mode.

CONSONANCE

Recharge

In charge termination mode, if the charge current rises above 20% of constant current, CN3153 will enter into charge mode again.

Constant-Current/Constant-Voltage/Constant-Temperature

The CN3153 use a unique architecture to charge a battery in a constant-current, constant-voltage, constant temperature fashion as shown in Figure 3. Amplifiers Iamp, Vamp, and Tamp are used in three separate feedback loops to force the charger into constant-current, constant-voltage, or constant-temperature mode, respectively. In constant current mode the charge current delivered to the battery equal to $1218V/R_{ISET}$. If the power dissipation of the CN3153 results in the junction temperature approaching 135°C, the amplifier Tamp will begin decreasing the charge current to limit the die temperature to approximately 135°C. As the battery voltage rises, the CN3153 either returns to constant-current mode or it enters constant voltage mode straight from constant-temperature mode.

Open-Drain Status Outputs

The CN3153 have 2 open-drain status outputs: \overline{CHRG} and \overline{DONE} . \overline{CHRG} is pulled low when the charger is in charging mode, otherwise \overline{CHRG} becomes high impedance. \overline{DONE} is pulled low if the charger is in charge termination mode, otherwise \overline{DONE} becomes high impedance.

When the battery voltage is lower than 0.75V for more than 10ms, \overline{CHRG} and \overline{DONE} becomes high impedance. The following table lists the two indicator status and its corresponding charging state. It is supposed that red LED is connected to \overline{CHRG} pin and green LED is connected to \overline{DONE} pin.

| \overline{CHRG} pin | \overline{DONE} pin | State Description |
|-----------------------------|-------------------------------|--|
| Low(red LED on) | High Impedance(green LED off) | Charging |
| High Impedance(red LED off) | Low(green LED on) | Charge termination |
| High Impedance(red LED off) | High Impedance(green LED off) | There are three possible state: <ul style="list-style-type: none">● the voltage at the VIN pin below the UVLO level or● the voltage at the VIN pin below V_{BAT} or● the battery voltage is below 0.75V |

Grounding \overline{CHRG} or \overline{DONE} pins if not used.

Stability

Typically a 4.7uF to 10uF capacitor(C2 in Figure 1 and 2) from BAT pin to GND is required to stabilize the feedback loop.

In constant current mode, the stability is also affected by the impedance at the ISET pin . With no additional capacitance on the ISET pin, the loop is stable with current set resistors values as high as 50K Ω . However, additional capacitance on ISET pin reduces the maximum allowed current set resistor. The pole frequency at ISET pin should be kept above 200KHz. Therefore, if ISET pin is loaded with a capacitance C, the following equation should be used to calculate the maximum resistance value for R_{ISET} :

$$R_{ISET} < 1 / (6.28 \times 2 \times 10^5 \times C)$$

Board Layout Considerations

1. R_{ISET} at ISET pin should be as close to CN3153 as possible, also the parasitic capacitance at ISET pin should be kept as small as possible.
2. The capacitance at VIN pin and BAT pin should be as close to CN3153 as possible.
3. It is very important to use a good thermal PC board layout to maximize charging current. The thermal path

CONSONANCE

for the heat generated by the IC is from the die to the copper lead frame through the package lead (especially the ground lead) to the PC board copper, the PC board copper is the heat sink. The footprint copper pads should be as wide as possible and expand out to larger copper areas to spread and dissipate the heat to the surrounding ambient. Feedthrough vias to inner or backside copper layers are also useful in improving the overall thermal performance of the charger. Other heat sources on the board, not related to the charger, must also be considered when designing a PC board layout because they will affect overall temperature rise and the maximum charge current. The ability to deliver maximum charge current under all conditions require that the exposed metal pad on the back side of the CN3153 package be soldered to the PC board ground. Failure to make the thermal contact between the exposed pad on the backside of the package and the copper board will result in larger thermal resistance.

CONSONANCE

Package Information

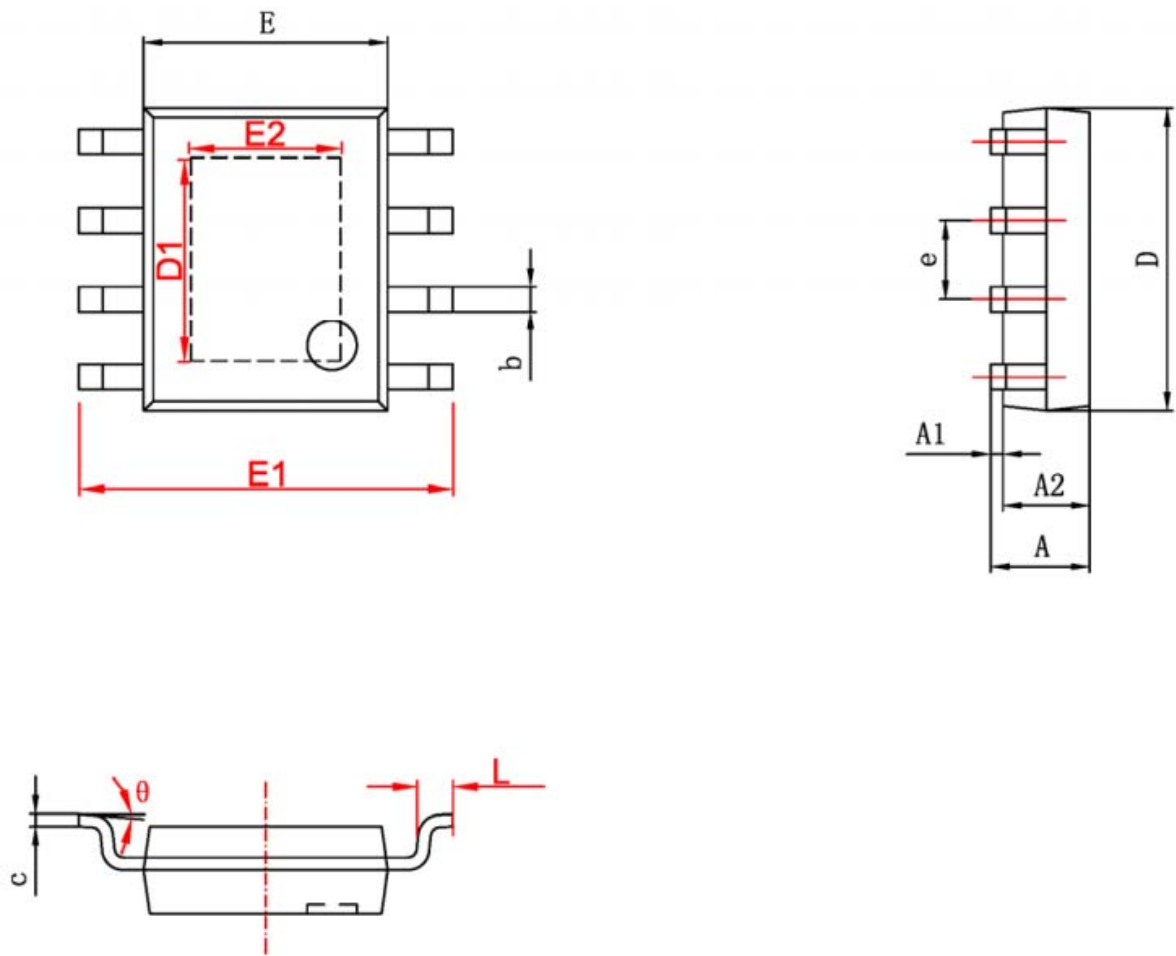

| 字符 | Dimensions In Millimeters | | Dimensions In Inches | |
|----|---------------------------|-------|----------------------|-------|
| | Min | Max | Min | Max |
| A | 1.350 | 1.750 | 0.053 | 0.069 |
| A1 | 0.050 | 0.150 | 0.004 | 0.010 |
| A2 | 1.350 | 1.550 | 0.053 | 0.061 |
| b | 0.330 | 0.510 | 0.013 | 0.020 |
| c | 0.170 | 0.250 | 0.006 | 0.010 |
| D | 4.700 | 5.100 | 0.185 | 0.200 |
| D1 | 3.202 | 3.402 | 0.126 | 0.134 |
| E | 3.800 | 4.000 | 0.150 | 0.157 |
| E1 | 5.800 | 6.200 | 0.228 | 0.244 |
| E2 | 2.313 | 2.513 | 0.091 | 0.099 |
| e | 1.270 (BSC) | | 0.050 (BSC) | |
| L | 0.400 | 1.270 | 0.016 | 0.050 |
| θ | 0° | 8° | 0° | 8° |

Consonance does not assume any responsibility for use of any circuitry described. Consonance reserves the right to change the circuitry and specifications without notice at any time.