

# CONSONANCE

## Low-Power, Single-Supply Op Amp + Reference CN958

### General Description

The CN958 features combinations of a low power operational amplifier and bandgap reference in an 6-pin SOT23 package. The CN958 operates from a single 2.5V to 5.5V supply with a typical supply current of 60uA. The op amp features a common-mode input voltage range that extends from the negative supply rail to the positive supply rail, as well as output stage that swings Rail-to-Rail. The op amp in the CN958 is internally compensated to be unity-gain stable with 0.6V/uS slew rate. The op amp has a unique output stage that enables it to operate with a low supply current while maintaining linearity under loaded conditions. In addition, the device has been designed to exhibit good DC characteristics over the entire operating temperature range.

The device is available in 6 pin SOT23 package.

### Features

- Op Amp + Bandgap Reference
- Operating Current: 60uA@4V
- Rail-to-Rail Input and Output
- 2.5V to 5.5V Supply Voltage Range
- Internally Frequency Compensated for Unity-Gain Stable
- Internal 1.205V  $\pm 2\%$  Bandgap Reference
- Op Amp Capable of Driving up to 200pF Load
- Operating Temperature Range:  
-40°C to 85°C
- Available in SOT23-6 Package
- Lead-free, Rohs-compliant and Halogen-free

### Applications

- Instruments, Terminals, and Bar-Code Readers
- Battery-Powered Systems
- Automotive Keyless Entry
- Low-Frequency, Local-Area Alarms/Detectors
- Photodiode Preamplifiers
- Audio Preamplifiers
- Infrared Receivers for Remote Controls
- Smoke Detectors and Safety Sensors

### Pin Assignment

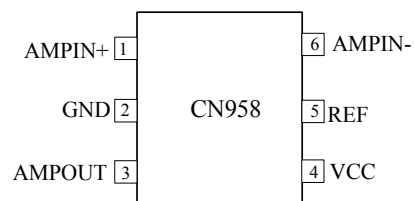

# CONSONANCE

## Typical Application Circuit

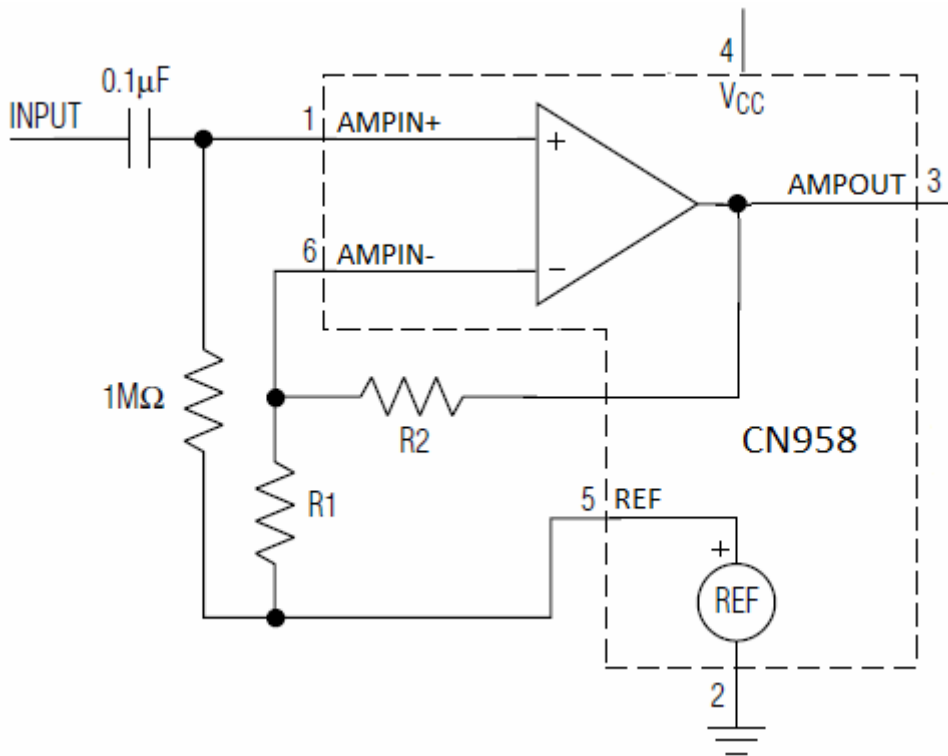

Figure 1 Typical Application Circuit

### Ordering Information:

Part No.	Package	Shipping	Operating Temperature Range
CN958	SOT23-6	Tape and Reel, 3000/Reel	-40°C to +85°C

# CONSONANCE

## Block Diagrams

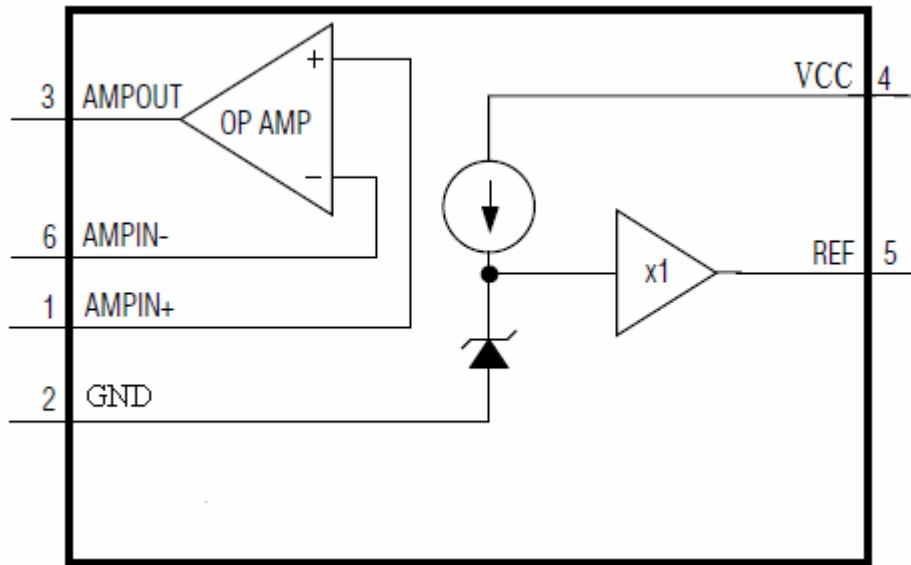

Figure 2 Block Diagram

## Pin Description

Pin No.	Symbol	Description
1	AMPIN+	<b>Non-inverting Op Amp Input.</b>
2	GND	<b>Negative Terminal of Power Supply or Ground.</b>
3	AMPOUT	<b>Op Amp Output.</b>
4	VCC	<b>Positive Terminal of Power Supply.</b>
5	REF	<b>Reference Voltage Output.</b> The reference voltage is 1.205V typical with $\pm 2\%$ accuracy.
6	AMPIN-	<b>Inverting Op Amp Input.</b>

## ABSOLUTE MAXIMUM RATINGS

Terminal Voltage (With Respect to GND)	Maximum Junction Temperatures.....+150°C
VCC.....-0.3V to +6.5V	Thermal Resistance.....200°C/W
The other Pins.....-0.3V to VCC	Operating Temperature.....-40 to +85°C
Input/Output Current	Storage Temperature.....-65 to +150°C
All Pins.....20mA	Lead Temperature (soldering, 10s) .....+260°C
Short-Circuit Duration	
REF and AMPOUT.....Continuous	

*Stresses beyond those listed under “Absolute Maximum Ratings” may cause permanent damage to the device. These are stress ratings only, and functional operation of the device at these or any other conditions beyond those indicated in the operational sections of the specifications is not implied. Exposure to absolute maximum rating conditions for extended periods may affect device reliability.*

# CONSONANCE

## Electrical Characteristics

(VCC=4V, TA= -40°C to 85°C, Typical values are at TA=25°C, unless otherwise noted.)

Parameters	Symbol	Test Conditions	Min	Typ	Max	Unit
Operating Voltage Range	VCC		2.5		5.5	V
Operating Current	I <sub>VCC</sub>	VCC=3.0V	35	55	75	uA
		VCC=5.0V	41	63	85	
<b>Reference</b>						
Reference Voltage	V <sub>REF</sub>	I <sub>REF</sub> = ±0uA	1.181	1.205	1.229	V
		REF Sink 25uA		1.207		
		REF Source 2.2mA		1.205		
<b>OP AMP</b>						
Input Offset Voltage	V <sub>OS</sub>				5	mV
Input Bias Current	I <sub>B</sub>			0.01	10	nA
DC Gain (No Load)	A <sub>vol</sub>	AMPOUT = 0.5V to 4.5V, VCC – GND = 5V		1000		V/mV
DC Gain (100kΩ Load to GND)	A <sub>vol</sub>	AMPOUT = 0.5V to 4.5V, VCC – GND = 5V		150		V/mV
Gain Bandwidth	GBW	AV = 1V/V, VCC – GND = 5V		950		kHz
Slew Rate	SR	AV = 1V/V		0.6		V/uS
Common-Mode Input Range	CMVR		0		VCC	V
Power-Supply Rejection Ratio	PSRR	DC	70	100		dB
		10KHz	20	40		
Output High Voltage	V <sub>OH</sub>	RL = 100kΩ to GND		5	9	mV
		RL = 10kΩ to GND		30	50	
		RL = 1kΩ to GND		300	500	
Output Low Voltage	V <sub>OL</sub>	RL = 100kΩ to VCC		2.5	5	mV
		RL = 10kΩ to VCC		18	30	
		RL = 1kΩ to VCC		150	250	
Output Short Current	I <sub>short</sub>	AMPOUT Short to GND		19		mA
		AMPOUT Short to VCC		43		mA

## Detailed Description

The CN958 is combination of a low power op amp and bandgap reference in a 6-pin SOT23 package, as shown in Figure 2. In the CN958, the bandgap reference voltage is 1.205V with ±2% accuracy. The device is optimized to operate from a single supply.

### Op Amp

The op amp in the CN958 is internally compensated to be unity-gain stable with 0.6V/uS slew rate. The op amp features high-impedance differential inputs and a common mode input voltage range that extends from the negative supply rail to within the positive rail. The CMOS output stage can swing rail to rail and is driven

# CONSONANCE

by a proprietary high gain stage, which enables it to operate with a low supply current while maintaining linearity under loaded conditions. Careful design results in good DC characteristics over their entire operating temperature range, minimizing input referred errors.

## Bandgap Reference

The internal reference in the CN958 has an output of 1.205V with respect to GND. Its accuracy is  $\pm 2\%$  in the  $-40^{\circ}\text{C}$  to  $+85^{\circ}\text{C}$  temperature range. It is comprised of a trimmed bandgap reference fed by a proportional to absolute-temperature (PTAT) current source and buffered by a micropower unity-gain amplifier. The REF output is typically capable of sinking  $25\mu\text{A}$  and sourcing  $2.2\text{mA}$  current. Do not bypass the reference output. The reference is stable for capacitive loads less than  $80\text{pF}$ .

## Application Information

### Input Noise Considerations

Because low power requirements often demand high impedance circuits, effects from radiated noise are more significant. Thus, traces between the op amp inputs and any resistor networks attached should be kept as short as possible.

### Power-Supply Bypassing

Power-supply bypass capacitor is not required if the supply impedance is low. For single-supply applications, it is good practice to bypass VCC with a  $0.1\mu\text{F}$  capacitor to ground, especially if there is high frequency noise on power supply.

Do not bypass the reference output.

### Driving Capacitive Loads

The CN958's amplifier is unity-gain stable for loads up to  $200\text{pF}$ . However, the capacitive load can be increased to  $2\text{nF}$  when the amplifier is configured for a minimum gain of  $10\text{V/V}$ . Applications that require greater capacitive-drive capability should use an isolation resistor between the output and the capacitive load as shown in Figure 3. Also, in unity-gain applications with relatively small  $R_L$  (approximately  $10\text{k}\Omega$ ), the capacitive load can be increased up to  $600\text{pF}$ .

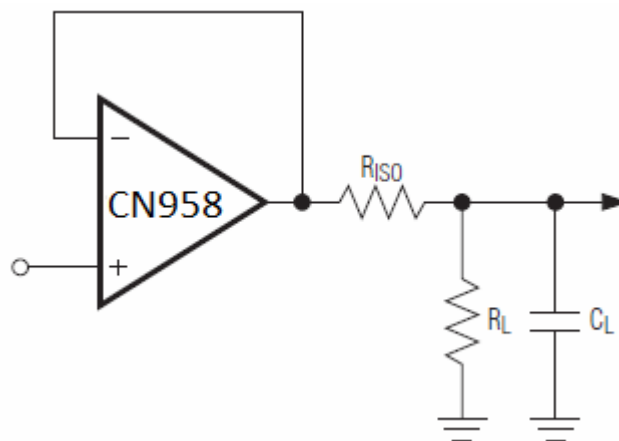

Figure 3 Using a Resistor to Isolate a Capacitive Load from the Op Amp

In Figure 3,  $R_{ISO}$  should be much smaller than  $R_L$ .

### Op Amp Stability and Board Layout Considerations

The op amp in the CN958 maintains stability in their minimum gain configuration while driving heavy capacitive loads. Good layout is extremely important for stable operation. Low-power, high-impedance circuits may increase the effects of board leakage and stray capacitance. For example, the combination of a  $10\text{M}\Omega$

# ***CONSONANCE***

---

resistance (from leakage between traces on a contaminated, poorly designed PC board) and a 1pF stray capacitance provides a pole at approximately 16kHz, which is within the amplifier's bandwidth. Board routing and layout should minimize leakage and stray capacitance. In some cases, stray capacitance may be unavoidable and it may be necessary to add a 2pF to 10pF capacitor across the feedback resistor to compensate, select the smallest capacitor value that ensures stability.

# CONSONANCE

## Package Information

SOT-23-6L(12R) PACKAGE OUTLINE DIMENSIONS

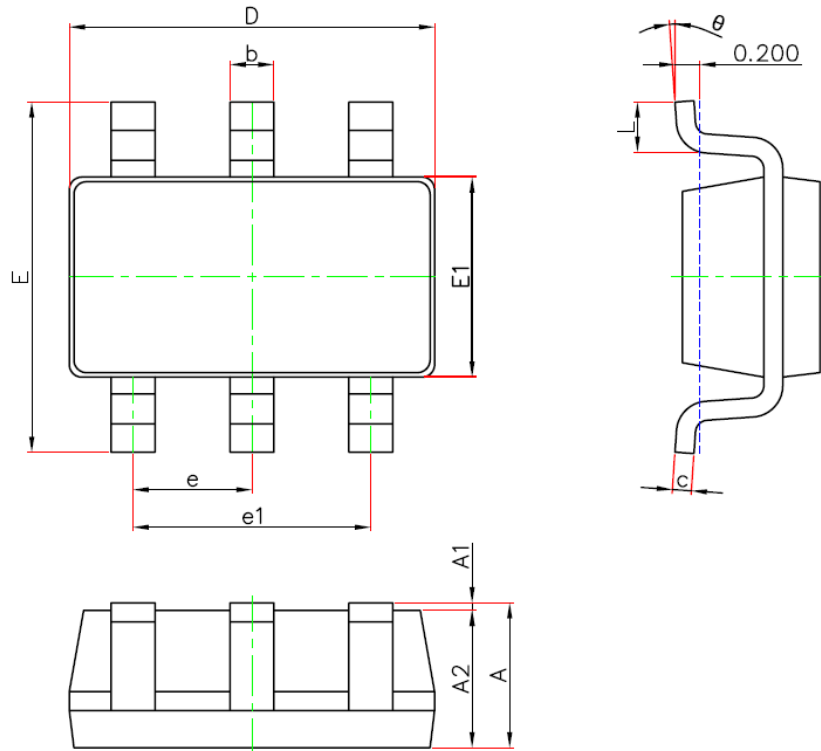

Symbol	Dimensions In Millimeters		Dimensions In Inches	
	Min.	Max.	Min.	Max.
A	1.050	1.250	0.041	0.049
A1	0.000	0.100	0.000	0.004
A2	1.050	1.150	0.041	0.045
b	0.300	0.500	0.012	0.020
c	0.100	0.200	0.004	0.008
D	2.820	3.020	0.111	0.119
E1	1.500	1.700	0.059	0.067
E	2.650	2.950	0.104	0.116
e	0.950(BSC)		0.037(BSC)	
e1	1.800	2.000	0.071	0.079
L	0.300	0.600	0.012	0.024
θ	0°	8°	0°	8°

Consonance does not assume any responsibility for use of any circuitry described. Consonance reserves the right to change the circuitry and specifications without notice at any time.