

**Specifications for**  
**Blanview TFT-LCD Monitor**  
**( 4.8" HD 720 x RGB x 1280 Portrait)**

Version 3.0

(Please be sure to check the specifications latest version. )

**MODEL COM48H4N22ULC**

Customer's Approval

Signature:

Name:

Section:

Title:

Date:

# ORTUSTECH

ORTUS TECHNOLOGY CO., LTD.

Approved by

\_\_\_\_\_ *N. Konyu*

Checked by

\_\_\_\_\_ *Y. Sato*

Prepared by

\_\_\_\_\_ *M. Jojo*



## 1. Application

This Specification is applicable to 120.7mm (4.75 inch) Blanview TFT-LCD monitor for non-military use.

- ⊙ ORTUS TECHNOLOGY makes no warranty or assume no liability that use of this Product and/or any information including drawings in this Specification by Purchaser is not infringing any patent or other intellectual property rights owned by third parties, and ORTUS TECHNOLOGY shall not grant to Purchaser any right to use any patent or other intellectual property rights owned by third parties. Since this Specification contains ORTUS TECHNOLOGY'S confidential information and copy right, Purchaser shall use them with high degree of care to prevent any unauthorized use, disclosure, duplication, publication or dissemination of ORTUS TECHNOLOGY'S confidential information and copy right.
- ⊙ If Purchaser intends to use this Products for an application which requires higher level of reliability and/or safety in functionality and/or accuracy such as transport equipment (aircraft, train, automobile, etc.), disaster-prevention/security equipment or various safety equipment, Purchaser shall consult ORTUS TECHNOLOGY on such use in advance.
- ⊙ This Product shall not be used for application which requires extremely higher level of reliability and/or safety such as aerospace equipment, telecommunication equipment for trunk lines, control equipment for nuclear facilities or life-support medical equipment.
- ⊙ It must be noted as a mechanical design manner, especial attention in housing design to prevent arcuation/flexure or caused by stress to the LCD module shall be considered.
- ⊙ ORTUS TECHNOLOGY assumes no liability for any damage resulting from misuse, abuse, and/or miss-operation of the Product deviating from the operating conditions and precautions described in the Specification.
- ⊙ It shall be mutually conferred if nonconforming defect which result from unspecified cause in this specification arises.
- ⊙ If any issue arises as to information provided in this Specification or any other information, ORTUS TECHNOLOGY and Purchaser shall discuss them in good faith and seek solution.
- ⊙ ORTUS TECHNOLOGY assumes no liability for defects such as electrostatic discharge failure occurred during peeling off the protective film or Purchaser's assembly process.
- ⊙ This Product is compatible for RoHS directive.

Object substance	Maximum content [ppm]
Cadmium and its compound	100
Hexavalent Chromium Compound	1000
Lead & Lead compound	1000
Mercury & Mercury compound	1000
Polybrominated biphenyl series (PBB series)	1000
Polybrominated biphenyl ether series (PBDE series)	1000

## 2. Summary

This documentation is for a LCD monitor model № COM48H4N22ULC , which has high picture quality, 16,777,216-color, 4.8" TFT display with 720 x RGB(H) x 1280(V) dots .

### Characteristics

16,777,216-color display ( 8-bit for R , G and B)

MIPI DSI(Display Serial Interface) Interface

- Support DSI Version 1.02
- Support D-PHY Version 1.00
- Support Video mode only.
- Support Non-Burst mode only.

	Indoor		Outdoor	
	Readability	Power Efficiency (Battery Life)	Readability	Power Efficiency (Battery Life)
Transmissive	Good	Good	Fair	Poor
Transflective	Fair	Poor	Good	Good
Blanview	Good	Good	Good	Good

## 3. General Specifications

### 3.1 Overall specification

Item	Details	
Product description	LCD monitor with MIPI DSI interface circuit	
Input Signal	MIPI DSI 4-lanes : 4 data lanes and 1 clock lane	
Back light type	High brightness LED, side light	
Outer dimension	63.68mm(H) x 115.51mm(V) x 1.67mm(D)	
Weight	25.2g	
Surface hardness of the polarizer	2H	Load: 2.94 N

### 3.2 TFT Specifications

Display size	4.8 inch diagonal	
Module		
Display type	Blanview, normally Black	
Resolution	720 x RGB(H) x 1280 (V)	
Dot pitch	27.4 μm(H) x 82.2 μm(V)	
Pixel arrangement	RGB stripe arrangement	
Active area	59.184 mm(H) x 105.216 mm(V)	

<Features of Blanview>

- Backlight power consumption required to assure visibility. (equivalent to 3.5"QVGA )

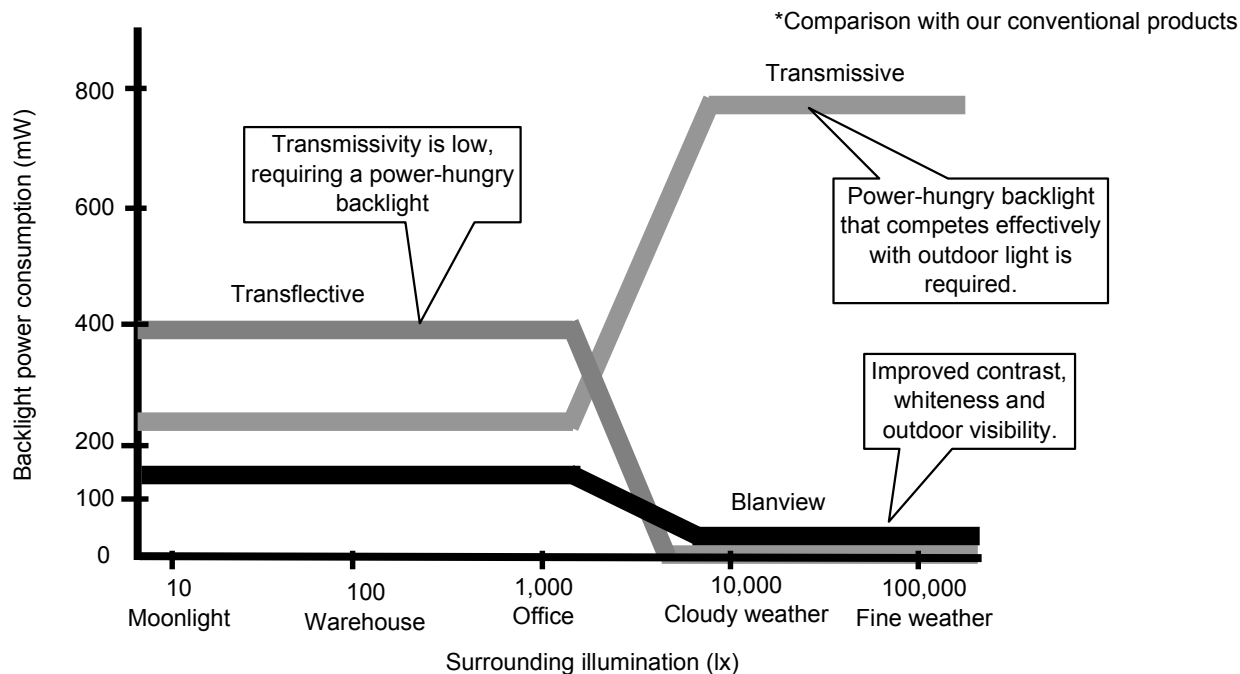

- Contrast characteristics under 100,000lx. (same condition as direct sunlight.)

With better contrast (higher contrast ratio), Blanview TFT-LCD has the best outdoor readability in three different types of TFT-LCD.

Below chart shows contrast value against panel surface brightness. (Horizontal: Panel surface brightness/ Vertical: Contrast value) LCD panel has enough outdoor readability above our Standard line. (ORTUS TECHNOLOGY criteria)

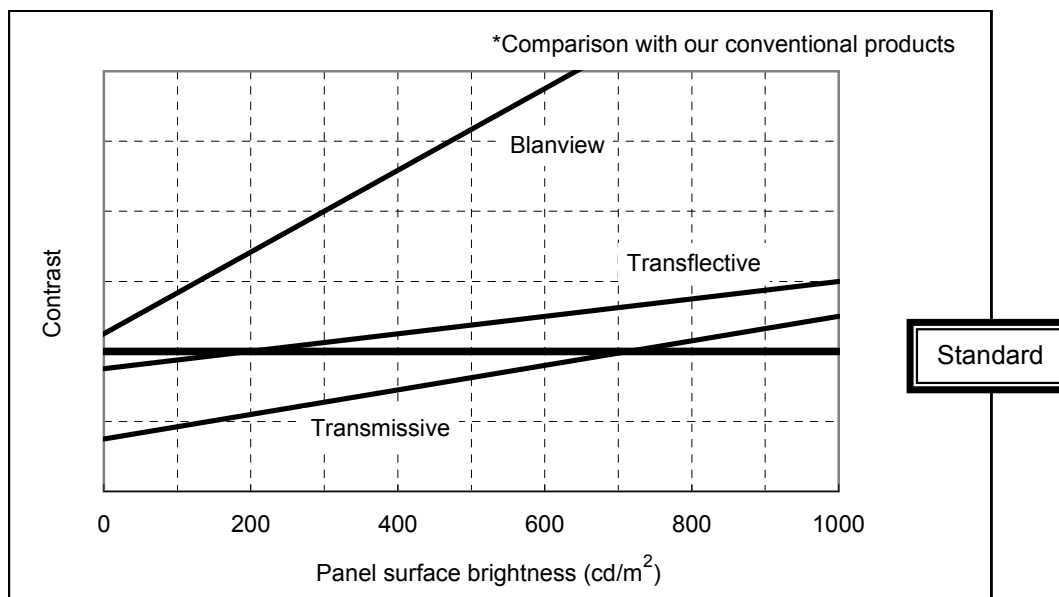



### 3.4 Serial Label (S-Label)

#### 1) Display Items

S-label indicates the least significant digit of manufacture year (1digit),  
 manufacture month with below alphabet (1letter),  
 model code (5characters), serial number (6digits).

\* Contents of Display

*	*	*****	*****
-	-	-	-
a	b	c	d

Contents of display				
a	The least significant digit of manufacture year			
b	Manufacture month	Jan-A Feb-B Mar-C Apr-D	May-E Jun-F Jul-G Aug-H	Sep-I Oct-J Nov-K Dec-L
c	Model code	48AKC (Made in Japan) 48ALC (Made in Malaysia)		
d	Serial number			

\* Example of indication of Serial label (S-label)

•Made in Japan

7D48AKC000125

means "manufactured in April 2017, 4.8" AK type, C specifications, serial number 000125"

•Made in Malaysia

7D48ALC000125

means "manufactured in April 2017, 4.8" AL type, C specifications, serial number 000125"

#### 2) Location of Serial Label (S-label)

Refer to 3.3 "Outward Form".

### 4. Block Diagram

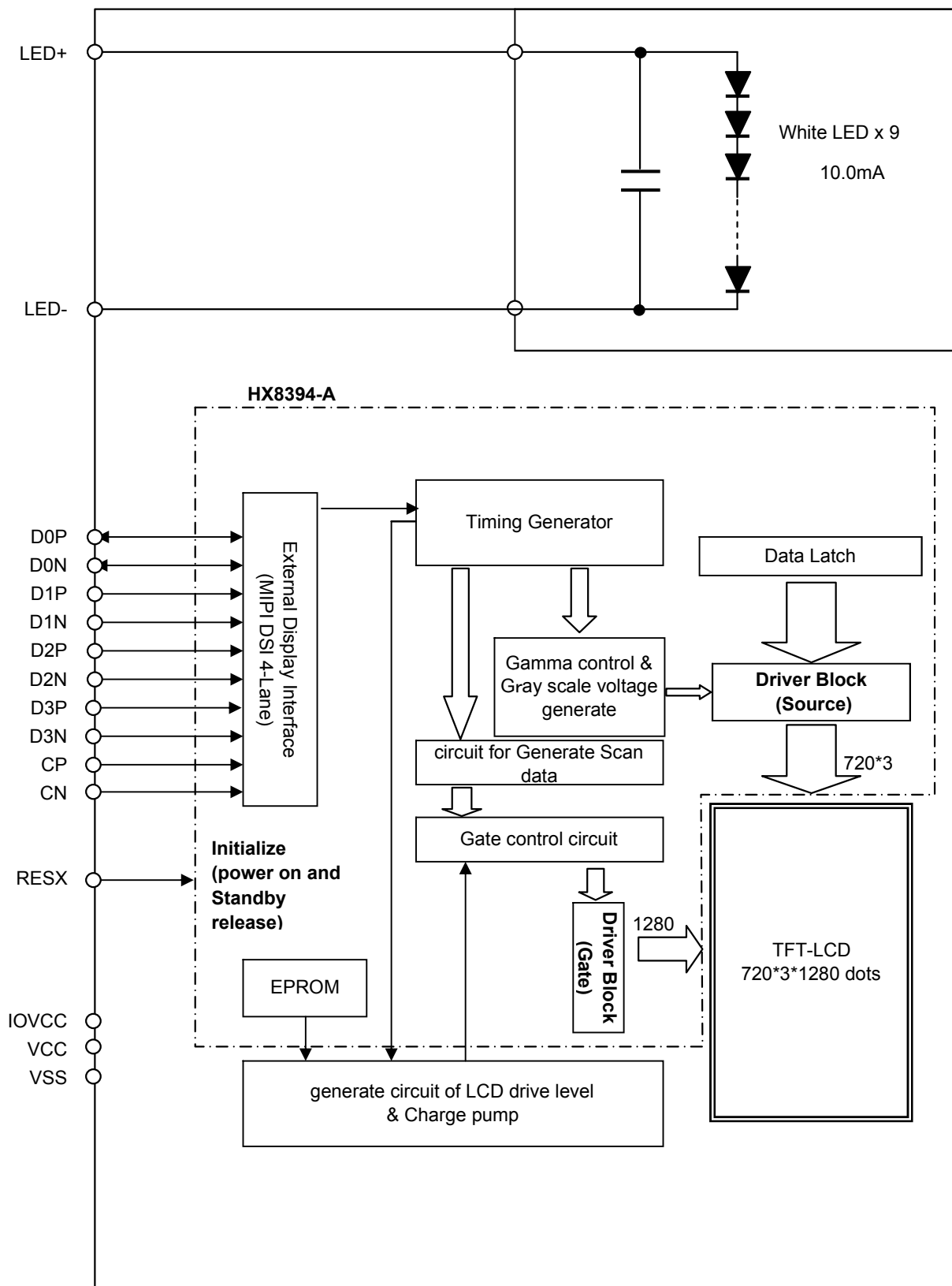



**5.FPC Terminals**

No.	Symbol	Details	Remark	IO
1	VSS	Ground		P
2	LED+	Backlight LED Anode		P
3	LED-	Backlight LED Cathode		P
4	VSS	Ground		P
5	VCC	Analog Power Supply	VCC = 2.9V (TYP)	P
6	IOVCC	DSI and I/O Power Supply	IOVCC = 1.9V (TYP)	P
7	VSS	Ground		P
8	RESX	LCD Reset	L:Initialize Power_ON Reset is Required when Turning on the Power	I
9	TEST OUT	TEST Signal output	Test Pin. Please Open this pin	O
10	VSS	Ground		P
11	D3N	MIPI-DSI Data differential signal input pin (Data lane 3)		I
12	D3P	MIPI-DSI Data differential signal input pin (Data lane 3)		I
13	VSS	Ground		P
14	VSS	Ground		P
15	D2P	MIPI-DSI Data differential signal input pin (Data lane 2)		I
16	D2N	MIPI-DSI Data differential signal input pin (Data lane 2)		I
17	VSS	Ground		P
18	CP	MIPI-DSI Clock differential signal input pin		I
19	CN	MIPI-DSI Clock differential signal input pin		I
20	VSS	Ground		P
21	D1P	MIPI-DSI Data differential signal input pin (Data lane 1)		I
22	D1N	MIPI-DSI Data differential signal input pin (Data lane 1)		I
23	VSS	Ground		P
24	D0P	MIPI-DSI Data differential signal input pin (Data lane 0)		IO
25	D0N	MIPI-DSI Data differential signal input pin (Data lane 0)		IO
26	VSS	Ground		P

## 6. About MIPI Interface

### 6.1 Version

The DSI incorporated in the LCD-Driver complies with the following standards.

MIPI DSI : Version 1.02

MIPI D-PHY : Version 1.00

Data transfer mode : Video mode only.

Burst mode : Non-burst mode only.

Virtual Channel : Set to VC[1:0]=00.

(It works even VC[1:0] = 00 other, but if you data read at VC = 00 other than, you will "DSI VC ID Invalid" error.)

### 6.2 Packet data types

The set of transaction types sent from the host processor to a peripheral, such as a display module, are shown in Table "Data Types for Processor-sourced Packets".

Data Types for Processor-sourced Packets.

Data Type Hex	Description	Size
01 h	Sync Event , V Sync Start	Short
11 h	Sync Event , V Sync End	Short
21 h	Sync Event , H Sync Start	Short
31 h	Sync Event , H Sync End	Short
22 h	Shut Down Peripheral Command	Short
32 h	Turn On Peripheral Command	Short
08 h	End of Transmission Packet (EoTp)	Short
05 h	DCS WRITE , no parameters	Short
15 h	DCS WRITE , 1 parameters	Short
06 h	DCS READ , no parameters	Short
37 h	Set Maximum Return Packet Size	Short
09 h	Null Packet , no data	Long
19 h	Blanking Packet , no data	Long
39 h	DCS Long Write/write_LUT Command Packet	Long
0E h	Packed Pixel Stream , 16-bit RGB , 5-6-5 Format	Long
1E h	Packed Pixel Stream , 18-bit RGB , 6-6-6 Format	Long
2E h	Loosely Packed Pixel Stream , 18-bit RGB , 6-6-6 Format	Long
3E h	Packed Pixel Stream , 24-bit RGB , 8-8-8 Format	Long

1. Not Support Checksum calculation and detection.
2. Not support "EoT Sync Error", "False Control", "Checksum Error", "Invalid Transmission Length" Error Report.
3. Not support "Generic Short WRITE, no parameters" Data Type.

**7.Command list****7.1 Standard command**

(Hex)	Register	DNC	D7	D6	D5	D4	D3	D2	D1	D0	Default (Hex)	recommend (Hex)		
00	NOP	0	0	0	0	0	0	0	0	0				
01	SWRESET	0	0	0	0	0	0	0	0	1				
04	RDDIDIF	0	0	0	0	0	0	1	0	0				
		1	ID1[7:0]									-	-	
		1	1	ID2[6:0]									-	-
		1	ID3[7:0]									-	-	
05	RDNUMPE	0	0	0	0	0	0	1	0	1				
		1	P[7:0]									-	-	
06	RDRED	0	0	0	0	0	0	1	1	0				
		1	R7	R6	R5	R4	R3	R2	R1	R0	-	-		
07	RDGREEN	0	0	0	0	0	0	1	1	1				
		1	G7	G6	G5	G4	G3	G2	G1	G0	-	-		
08	RDBLUE	0	0	0	0	0	1	0	0	0				
		1	B7	B6	B5	B4	B3	B2	B1	B0	-	-		
09	RDDST	0	0	0	0	0	1	0	0	1				
		1	D[31:24]									-	-	
		1	D[23:16]									-	-	
		1	D[15:8]									-	-	
0A	RDDPM	0	0	0	0	0	1	0	1	0				
		1	0	D6	0	D4	D3	D2	-	-	-	-		
0B	RDDMADCTL	0	0	0	0	0	1	0	1	1				
		1	-	-	-	-	D3	-	D1	D0	-	-		
0C	RDDCOLMOD	0	0	0	0	0	1	1	0	0				
		1	-	D6	D5	D4	-	-	-	-	-	-		
0D	RDDIM	0	0	0	0	0	1	1	0	1				
		1	-	-	D5	D4	D3	D2	D1	D0	-	-		
0E	RDDSM	0	0	0	0	0	1	1	1	0				
		1	D7	D6	D5	D4	D3	D2	-	-	-	-		
0F	RDDSDR	0	0	0	0	0	1	1	1	1				
		1	D7	D6	D5	D4	D3	D2	-	-	-	-		
10	SLPIN	0	0	0	0	1	0	0	0	0				
11	SLPOUT	0	0	0	0	1	0	0	0	1				
13	NORON	0	0	0	0	1	0	0	1	1				
20	INVOFF	0	0	0	1	0	0	0	0	0		INVOFF		
21	INVON	0	0	0	1	0	0	0	0	1				
26	GAMSET	0	0	0	1	0	0	1	1	0				
		1	GC[7:0]									-	-	
28	DISPOFF	0	0	0	1	0	1	0	0	0				
29	DISPON	0	0	0	1	0	1	0	0	1				
34	TEOFF	0	0	0	1	1	0	1	0	0				
35	TEON	0	0	0	1	1	0	1	0	1				
		1	-	-	-	-	-	-	-	M	-	-		

(Hex)	Register	DNC	D7	D6	D5	D4	D3	D2	D1	D0	Default (Hex)	recommend (Hex)	
36	MADCTL	0	0	0	1	1	0	1	1	0			
		1	-	-	-	-	B3	-	B1	B0	-	00	
38	IDMOFF	0	0	0	1	1	1	0	0	0			
39	IDMON	0	0	0	1	1	1	0	0	1			
3A	COLMOD	0	0	0	1	1	1	0	1	0			
		1	-	D6	D5	D4	-	-	-	-	-	-	70
44	TESL	0	0	1	0	0	0	1	0	0			
		1	TELINE[15:8]									-	-
		1	TELINE[7:0]									-	-
45	GETSCAN	0	0	1	0	0	0	1	0	1			
		1	SLN[15:8]									-	-
		1	SLN[7:0]									-	-
51	WRDISBV	0	0	1	0	1	0	0	0	1			
		1	DBV[7:0]									-	FF
52	RDISBV	0	0	1	0	1	0	0	1	0			
		1	DBV[7:0]									-	-
53	WRCTRLD	0	0	1	0	1	0	0	1	1			
		1	-	-	BCTRL	-	DD	BL	-	-	-	-	00
54	RDCTRLD	0	0	1	0	1	0	1	0	0			
		1	0	0	BCTRL	0	DD	BL	0	0	-	-	
55	WRCABC	0	0	1	0	1	0	1	0	1			
		1	-	-	-	-	-	-	-	CABC[1:0]	-	00	
56	RDCABC	0	0	1	0	1	0	1	1	0			
		1	0	0	0	0	0	0	0	C1	C0	-	-
5E	WRCABCMB	0	0	1	0	1	1	1	1	0			
		1	CMB[7:0]									-	-
5F	RDCABCMB	0	0	1	0	1	1	1	1	1			
		1	CMB[7:0]									-	-
68	RDABCSDR	0	0	1	1	0	1	0	0	0			
		1	D[7:6]			0	0	0	0	0	0		
A1	Read_DDB_start	0	1	0	1	0	0	0	0	1			
		1	xx	xx	xx	xx	xx	xx	xx	xx	xx	-	-
		1	xx	xx	xx	xx	xx	xx	xx	xx	xx	-	-
		1	xx	xx	xx	xx	xx	xx	xx	xx	xx	-	-
A8	Read_DDB _continue	0	1	0	1	0	1	0	0	0			
		1	xx	xx	xx	xx	xx	xx	xx	xx	xx	-	-
		1	xx	xx	xx	xx	xx	xx	xx	xx	xx	-	-
		1	xx	xx	xx	xx	xx	xx	xx	xx	xx	-	-

## 7.2 User define command (User define command list is available only set "SETEXTC" command.)

(Hex)	Register	DNC	D7	D6	D5	D4	D3	D2	D1	D0	Default (Hex)	recommend (Hex)				
B1	SETPOWER	0	1	0	1	1	0	0	0	1						
		1	-	VSN_EN	VSP_EN	VGL_EN	VGH_EN	VCL_EN	VDDDN_HZ	STB		01	7C			
		1	-	-	-	-	-	-	VIBIAS_EN	LVGL_EN		00	00			
		1	-	FS1[2:0]			-	AP[2:0]				34	24			
		1	CLK_OPT2	CLK_OPT1	DC_VPNL[1:0]		BT[3:0]					07	06			
		1	DT[1:0]		-	-	DCDIV[3:0]					03	01			
		1	-	-	-	BTP[4:0]					0E	10				
		1	DCS[2:0]			BTN[4:0]					0E	10				
		1	VRHP[7:0]										21	26		
		1	VRHN[7:0]										29	2E		
		1	-	-	VRMP[5:0]								19	1D		
		1	-	-	VRMN[5:0]								19	1D		
		1	-	APF_EN	DD_TU	-	-	VBS[2:0]				57	57			
		1	-	DC86_DIV[3:0]				XDK[1:0]		AUTO_XDK			12	12		
		1	A_DC[2]	DTPS[2:0]			-	DTNS[2:0]					01	01		
		1	A_DC[1:0]		A_DTP[2:0]			A_DTN[2:0]					E6	E6		
		1	TEST COMMAND										-	E2		
B2	SETDISP	0	1	0	1	1	0	0	1	0						
		1	-	-	-	-	GON	DTE	D[1:0]			08	00			
		1	NL[7:0]										C8	C8		
		1	BP[7:0]										04	04		
		1	FP[7:0]										04	04		
		1	RTN[7:0]										26	00		
B4	SETCYC	0	1	0	1	1	0	1	0	0						
		1	-	-	NW_PE[2:0]			NW[2:0]				80	00			
		1	USER_GIP_GATE[7:0]										08	04		
		1	SHR0_3[3:0]				SHR0_2[3:0]								32	32
		1	SHR0_1[3:0]				SHR0_0[11:8]								10	10
		1	SHR0[7:0]										0	00		
		1	SHR1_3[3:0]				SHR1_2[3:0]								32	32
		1	SHR1_1[3:0]				SHR1_0[11:8]								13	15
		1	SHR1[7:0]										C0	05		
		1	SHR2_3[3:0]				SHR2_2[3:0]								32	32
		1	SHR2_1[3:0]				SHR2_0[11:8]								10	10
		1	SHR2[7:0]										08	08		
		1	SHP[3:0]				SCP[3:0]								23	27
		1	SPON[7:0]										06	01		
		1	SPOFF[7:0]										44	43		
		1	CHR[7:0]										04	03		
		1	CHP[3:0]				CCP[3:0]								27	37
1	CON[7:0]										06	01				
1	COFF[7:0]										5F	43				
1	SON[7:0]										0A	01				
1	SOFF[7:0]										6B	61				
1	EQON2[7:0]										70	61				

(Hex)	Register	DNC	D7	D6	D5	D4	D3	D2	D1	D0	Default (Hex)	recommend (Hex)
		1	EQON1[7:0]								05	01
		1	SPON_MPU[7:0]								06	01
		1	SPOFF_MPU[7:0]								44	43
		1	CON_MPU[7:0]								06	01
		1	COFF_MPU[7:0]								5F	43
		1	SON_MPU[7:0]								0A	01
		1	SOFF_MPU[7:0]								6B	61
		1	EQON2_MPU[7:0]								70	61
		1	EQON1_MPU[7:0]								05	01
		1	GIP_FR[1:0]	BLK_OSCSEL	GIP16P	STV_AS_CHK	BLK_FR[1:0]	GIP_FR_MODE			00	-
B9	SETEXTC	0	1	0	1	1	1	0	0	1		
		1	EXTC1[7:0]								00/FF	FF
		1	EXTC2[7:0]								00/83	83
		1	EXTC3[7:0]								00/94	94
BA	SETMIPI	0	1	0	1	1	1	0	1	0		
		1	-	DSISSETUP0[6:0]								03
BC	SETVDC	0	1	0	1	1	1	1	0	0		
		1	-	-	-	-	-	VDC_SEL[2:0]				07
BF	Not open	0	1	0	1	1	1	1	1	1		
		1	TEST COMMAND								-	06
		1	TEST COMMAND								-	02
		1	TEST COMMAND								-	10
		1	TEST COMMAND								-	04
C0	Not open	0	1	1	0	0	0	0	0	0		
		1	TEST COMMAND								-	0C
		1	TEST COMMAND								-	15
C6	Not open	0	1	1	0	0	0	1	1	0		
		1	TEST COMMAND								-	08
		1	TEST COMMAND								-	08
C7	Not open	0	1	1	0	0	0	1	1	1		
		1	TEST COMMAND								-	00
		1	TEST COMMAND								-	10
		1	TEST COMMAND								-	00
		1	TEST COMMAND								-	10

(Hex)	Register	DNC	D7	D6	D5	D4	D3	D2	D1	D0	Default (Hex)	recommend (Hex)
C1	SETDGCLUT	0	1	1	0	0	0	0	0	1		C1
		1	-	-	-	-	-	-	DITH _OPT	DGC _EN	00	01
		1	D1[7:0]								00	00
		1	D2[7:0]								08	06
		1	D3[7:0]								10	0E
		1	D4[7:0]								18	16
		1	D5[7:0]								20	1E
		1	D6[7:0]								28	26
		1	D7[7:0]								30	2E
		1	D8[7:0]								38	36
		1	D9[7:0]								40	3E
		1	D10[7:0]								48	46
		1	D11[7:0]								50	4E
		1	D12[7:0]								58	56
		1	D13[7:0]								60	5E
		1	D14[7:0]								68	66
		1	D15[7:0]								70	6E
		1	D16[7:0]								78	76
		1	D17[7:0]								80	7E
		1	D18[7:0]								88	86
		1	D19[7:0]								90	8E
		1	D20[7:0]								98	96
		1	D21[7:0]								A0	9E
		1	D22[7:0]								A8	A6
		1	D23[7:0]								B0	AE
		1	D24[7:0]								B8	B6
		1	D25[7:0]								C0	BE
		1	D26[7:0]								C8	C6
		1	D27[7:0]								D0	CE
		1	D28[7:0]								D8	D6
		1	D29[7:0]								E0	DE
		1	D30[7:0]								E8	E6
		1	D31[7:0]								F0	EE
		1	D32[7:0]								F8	F6
		1	D33[7:0]								FF	FE
		1	D34[7:0]								00	00
		1	D35[7:0]								00	00
		1	D36[7:0]								00	00
		1	D37[7:0]								00	00
		1	D38[7:0]								00	00
		1	D39[7:0]								00	00
		1	D40[7:0]								00	00
		1	D41[7:0]								00	00
		1	D42[7:0]								00	00

(Hex)	Register	DNC	D7	D6	D5	D4	D3	D2	D1	D0	Default (Hex)	recommend (Hex)
		1					D43[7:0]				00	00
		1					D44[7:0]				08	03
		1					D45[7:0]				10	0B
		1					D46[7:0]				18	13
		1					D47[7:0]				20	1B
		1					D48[7:0]				28	23
		1					D49[7:0]				30	2B
		1					D50[7:0]				38	33
		1					D51[7:0]				40	3B
		1					D52[7:0]				48	43
		1					D53[7:0]				50	4B
		1					D54[7:0]				58	53
		1					D55[7:0]				60	5B
		1					D56[7:0]				68	63
		1					D57[7:0]				70	6B
		1					D58[7:0]				78	73
		1					D59[7:0]				80	7B
		1					D60[7:0]				88	83
		1					D61[7:0]				90	8B
		1					D62[7:0]				98	93
		1					D63[7:0]				A0	9B
		1					D64[7:0]				A8	A3
		1					D65[7:0]				B0	AB
		1					D66[7:0]				B8	B3
		1					D67[7:0]				C0	BB
		1					D68[7:0]				C8	C3
		1					D69[7:0]				D0	CB
		1					D70[7:0]				D8	D3
		1					D71[7:0]				E0	DB
		1					D72[7:0]				E8	E3
		1					D73[7:0]				F0	EB
		1					D74[7:0]				F8	F3
		1					D75[7:0]				FF	FB
		1					D76[7:0]				00	00
		1					D77[7:0]				00	00
		1					D78[7:0]				00	00
		1					D79[7:0]				00	00
		1					D80[7:0]				00	00
		1					D81[7:0]				00	00
		1					D82[7:0]				00	00
		1					D83[7:0]				00	00
		1					D84[7:0]				00	00



(Hex)	Register	DNC	D7	D6	D5	D4	D3	D2	D1	D0	Default (Hex)	recommend (Hex)
		1					D85[7:0]				00	00
		1					D86[7:0]				08	00
		1					D87[7:0]				10	08
		1					D88[7:0]				18	10
		1					D89[7:0]				20	18
		1					D90[7:0]				28	1E
		1					D91[7:0]				30	26
		1					D92[7:0]				38	2E
		1					D93[7:0]				40	36
		1					D94[7:0]				48	3E
		1					D95[7:0]				50	46
		1					D96[7:0]				58	4E
		1					D97[7:0]				60	56
		1					D98[7:0]				68	5E
		1					D99[7:0]				70	66
		1					D100[7:0]				78	6E
		1					D101[7:0]				80	76
		1					D102[7:0]				88	7E
		1					D103[7:0]				90	86
		1					D104[7:0]				98	8E
		1					D105[7:0]				A0	96
		1					D106[7:0]				A8	9E
		1					D107[7:0]				B0	A6
		1					D108[7:0]				B8	AE
		1					D109[7:0]				C0	B6
		1					D110[7:0]				C8	BE
		1					D111[7:0]				D0	C6
		1					D112[7:0]				D8	CE
		1					D113[7:0]				E0	D6
		1					D114[7:0]				E8	DE
		1					D115[7:0]				F0	E6
		1					D116[7:0]				F8	ED
		1					D117[7:0]				FF	F5
		1					D118[7:0]				00	00
		1					D119[7:0]				00	00
		1					D120[7:0]				00	00
		1					D121[7:0]				00	00
		1					D122[7:0]				00	00
		1					D123[7:0]				00	00
		1					D124[7:0]				00	00
		1					D125[7:0]				00	00
		1					D126[7:0]				00	00

(Hex)	Register	DNC	D7	D6	D5	D4	D3	D2	D1	D0	Default (Hex)	recommend (Hex)		
C9	SETCABC	0	1	1	0	0	1	0	0	1				
		1	-	SEL_PWMCLK[2:0]			SEL_GAIN[1:0]		INVPULS	SEL_BLDUTY	2F	0F		
		1	PWM_PERIOD[7:0]									2B	00	
		1	CABC_FSYNC	DIM_FRAME[6:0]									1E	1E
		1	CABC_STEP[7:0]									1E	1E	
		1	CABC_CLKEN[7:0]									00	00	
		1	CABC_DD	SAVEPOWER[6:0]									00	00
		1	MEAN_OFFSET[7:0]									00	00	
		1	-	-	-	-	CABC_FLM[3:0]				01	01		
		1	-	-	EN_DIM_MIX	EN_COST_MEAN	EN_COST	EN_NLN_GAIN	EN_JUDGE	EN_TEMP	3E	3E		
CC	SETPANEL	0	1	1	0	0	1	1	0	0				
		1	-	-	-	-	SS_PANEL	GS_PANEL	REV_PANEL	BGR_PANERL	02	09		
D5	SETGIP	0	1	1	0	1	0	1	0	1				
		1	-	-	-	-	-	-	-	-	00	00		
		1	-	-	-	-	EQ_DELAY_HSYNC[3:0]				00	00		
		1	EQ_DELAY[7:0]									00	04	
		1	-	-	-	MODE_94A	-	-	-	-	10	00		
		1	-	GIP_OPT[22:16]									0A	0A
		1	GIP_OPT[15:8]									00	00	
		1	GIP_OPT[7:0]									01	01	
		1	CGTS_L[19:16]					CGTS_R[19:16]					00	33
		1	CGTS_L[15:12]					CGTS_R[15:12]					00	00
		1	CGTS_L[11:8]					CGTS_R[11:8]					77	00
		1	CGTS_L[7:4]					CGTS_R[7:4]					88	33
		1	CGTS_L[3:0]					CGTS_R[3:0]					00	00
		1	COS1_L[3:0](CGOUT1_L)					COS1_R[3:0](CGOUT1_R)					78	10
		1	COS2_L[3:0](CGOUT2_L)					COS2_R[3:0](CGOUT2_R)					86	32
		1	COS3_L[3:0](CGOUT3_L)					COS3_R[3:0](CGOUT3_R)					5A	54
		1	COS4_L[3:0](CGOUT4_L)					COS4_R[3:0](CGOUT4_R)					84	76
		1	COS5_L[3:0](CGOUT5_L)					COS5_R[3:0](CGOUT5_R)					88	10
		1	COS6_L[3:0](CGOUT6_L)					COS6_R[3:0](CGOUT6_R)					78	32
		1	COS7_L[3:0](CGOUT7_L)					COS7_R[3:0](CGOUT7_R)					38	88
		1	COS8_L[3:0](CGOUT8_L)					COS8_R[3:0](CGOUT8_R)					86	88
		1	COS9_L[3:0](CGOUT9_L)					COS9_R[3:0](CGOUT9_R)					82	88
		1	COS10_L[3:0](CGOUT10_L)					COS10_R[3:0](CGOUT10_R)					58	88
		1	COS11_L[3:0](CGOUT11_L)					COS11_R[3:0](CGOUT11_R)					18	88
		1	COS12_L[3:0](CGOUT12_L)					COS12_R[3:0](CGOUT12_R)					84	88
		1	COS13_L[3:0](CGOUT13_L)					COS13_R[3:0](CGOUT13_R)					80	88
		1	COS14_L[3:0](CGOUT14_L)					COS14_R[3:0](CGOUT14_R)					88	99
1	COS15_L[3:0](CGOUT15_L)					COS15_R[3:0](CGOUT15_R)					38	99		
1	COS16_L[3:0](CGOUT16_L)					COS16_R[3:0](CGOUT16_R)					82	99		
1	COS17_L[3:0](CGOUT17_L)					COS17_R[3:0](CGOUT17_R)					00	54		
1	COS18_L[3:0](CGOUT18_L)					COS18_R[3:0](CGOUT18_R)					00	76		
1	COS19_L[3:0](CGOUT19_L)					COS19_R[3:0](CGOUT19_R)					00	88		
1	COS20_L[3:0](CGOUT20_L)					COS20_R[3:0](CGOUT20_R)					00	88		

(Hex)	Register	DNC	D7	D6	D5	D4	D3	D2	D1	D0	Default (Hex)	recommend (Hex)
E0	SETGAMMA	0	1	1	1	0	0	0	0	0		
		1	-	-	VRP0[5:0]				04	00		
		1	-	-	VRP1[5:0]				0C	00		
		1	-	-	VRP2[5:0]				0D	00		
		1	-	-	VRP3[5:0]				0A	12		
		1	-	-	VRP4[5:0]				15	1D		
		1	-	-	VRP5[5:0]				21	34		
		1	-	PRP0[6:0]				0D	13			
		1	-	PRP1[6:0]				19	2A			
		1	-	-	-	PKP0[4:0]				06	04	
		1	-	-	-	PKP1[4:0]				0C	0C	
		1	-	-	-	PKP2[4:0]				0F	12	
		1	-	-	-	PKP3[4:0]				13	16	
		1	-	-	-	PKP4[4:0]				16	19	
		1	-	-	-	PKP5[4:0]				14	16	
		1	-	-	-	PKP6[4:0]				15	16	
		1	-	-	-	PKP7[4:0]				0D	0E	
		1	-	-	-	PKP8[4:0]				13	11	
		1	-	-	VRN0[5:0]				04	00		
		1	-	-	VRN1[5:0]				0C	00		
		1	-	-	VRN2[5:0]				0D	00		
		1	-	-	VRN3[5:0]				0A	18		
		1	-	-	VRN4[5:0]				15	24		
		1	-	-	VRN5[5:0]				21	3F		
		1	-	PRN0[6:0]				0D	16			
		1	-	PRN1[6:0]				19	2C			
		1	-	-	-	PKN0[4:0]				06	04	
		1	-	-	-	PKN1[4:0]				0C	0D	
		1	-	-	-	PKN2[4:0]				0F	10	
		1	-	-	-	PKN3[4:0]				13	16	
		1	-	-	-	PKN4[4:0]				16	18	
		1	-	-	-	PKN5[4:0]				14	16	
		1	-	-	-	PKN6[4:0]				15	16	
		1	-	-	-	PKN7[4:0]				0D	10	
		1	-	-	-	PKN8[4:0]				13	11	
		1	-	-	-	PKP_EX0[4:0]				0A	07	
		1	-	-	-	PKP_EX1[4:0]				16	16	
		1	-	-	-	PKP_EX2[4:0]				06	06	
		1	-	-	-	PKP_EX3[4:0]				0F	0F	
		1	-	-	-	PKN_EX0[4:0]				07	08	
1	-	-	-	PKN_EX1[4:0]				16	16			
1	-	-	-	PKN_EX2[4:0]				06	07			
1	-	-	-	PKN_EX3[4:0]				11	10			
F4	GETHXID	0	1	1	1	1	0	1	0	0		
		1	Himax ID[7:0]								94	-

## 8. Sequence

PH :Packet Header

PD :Packet Data

PF:Packet Footer (=Checksum)



## 8.1 Power-ON Sequence

0		Function	DNC	Command /Parameter	Type	Command/Parameter
	Power on	VDD, VCCIO On				
	Wait	wait 1 msec or more				
	MIPI signal state	Keep CLKN/P, D0N/P, D1N/P D2N/P,D3N/P in STOP state LP-11 (Must be set to LP-11 is all lanes of MIPI before rising edge of RESX.)				
	H/W RESET	RESX=1				
		RESX=0 (Keep 10usec or more)				
		RESX=1				
	Wait	wait 10 msec or more				
1	SETEXTC	Set extension command	0	B9h	PH	[39 04 00 2C]
		Parameter 1	1	FFh	PD	[B9 FF 83 94]
		Parameter 2	1	83h	PF	[XX XX]
		Parameter 3	1	94h		
2	SETPOWER	Set power	0	B1h	PH	[39, 11, 00, 33]
		Parameter 1	1	7Ch	PD	[B1 7C 00 24 06 01 10 10 26 2E 1D 1D 57 12 01 E6 E2]
		Parameter 2	1	00h		
		Parameter 3	1	24h	PF	[XX XX]
		Parameter 4	1	06h		
		Parameter 5	1	01h		
		Parameter 6	1	10h		
		Parameter 7	1	10h		
		Parameter 8	1	26h		
		Parameter 9	1	2Eh		
		Parameter 10	1	1Dh		
		Parameter 11	1	1Dh		
		Parameter 12	1	57h		
		Parameter 13	1	12h		
		Parameter 14	1	01h		
		Parameter 15	1	E6h		
		Parameter 16	1	E2h		
3	SETDISP	Setdisp	0	B2h	PH	[39, 07, 00, 2A]
		Parameter 1	1	00h	PD	[B2 00 C8 04 04 00 22]
		Parameter 2	1	C8h		
		Parameter 3	1	04h	PF	[XX XX]
		Parameter 4	1	04h		
		Parameter 5	1	00h		
	Parameter 6	1	22h			
4	INVOFF	Exit inversion mode	0	20h	PH	[05 20 00 23]
5	MADCTL	Set address mode	0	36h	PH	[15 36 00 29]
		Parameter 1	1	00h		
6	COLMOD	Set_pixel_format	0	3Ah	PH	[15 3A 70 28]
		Parameter 1( 24bit/pixel)	1	70h		
7	SETCYC	Set display waveform cycle	0	B4h	PH	[39 1F 00 29]
		Parameter 1	1	00h	PD	[B4 00 04 32 10 00 32 15 05 32 10 08 27 01 43 03 37 01 43 01 61 61 01 01 43 01 43 01 61 61 01]
		Parameter 2	1	04h		
		Parameter 3	1	32h		
		Parameter 4	1	10h	PF	[XX XX]
		Parameter 5	1	00h		
		Parameter 6	1	32h		
		Parameter 7	1	15h		
		Parameter 8	1	05h		
		Parameter 9	1	32h		
		Parameter 10	1	10h		
		Parameter 11	1	08h		
		Parameter 12	1	27h		
		Parameter 13	1	01h		
		Parameter 14	1	43h		
		Parameter 15	1	03h		
		Parameter 16	1	37h		
		Parameter 17	1	01h		
		Parameter 18	1	43h		

No.		Function	DNC	Command /Parameter	Type	Command/Parameter
		Parameter 19	1	01h		
		Parameter 20	1	61h		
		Parameter 21	1	61h		
		Parameter 22	1	01h		
		Parameter 23	1	01h		
		Parameter 24	1	43h		
		Parameter 25	1	01h		
		Parameter 26	1	43h		
		Parameter 27	1	01h		
		Parameter 28	1	61h		
		Parameter 29	1	61h		
		Parameter 30	1	01h		
8	Not open		0	BFh	PH	[39, 05, 00, 36]
		Parameter 1	1	06h	PD	[BF 06 02 10 04]
		Parameter 2	1	02h		
		Parameter 3	1	10h	PF	[XX XX]
		Parameter 4	1	04h		
9	Not open		0	C7h	PH	[39, 05, 00, 36]
		Parameter 1	1	00h	PD	[C7 00 10 00 10]
		Parameter 2	1	10h		
		Parameter 3	1	00h	PF	[XX XX]
		Parameter 4	1	10h		
10	Not open		0	C6h	PH	[39, 03, 00, 09]
		Parameter 1	1	08h	PD	[C6 08 08]
		Parameter 2	1	08h		
					PF	[XX XX]
11	Not open		0	C0h	PH	[39, 03, 00, 09]
		Parameter 1	1	0Ch	PD	[C0 0C 15]
		Parameter 2	1	15h		
					PF	[XX XX]
12	SETGIP	Set GIP	0	D5h	PH	[39 21 00 3C]
		Parameter 1	1	00h		[D5 00 00 04 00 0A 00 01 33 00 00
		Parameter 2	1	00h	PD	33 00 10 32 54 76 10 32 88 88 88 88
		Parameter 3	1	04h		88 88 88 99 99 99 54 76 88 88]
		Parameter 4	1	00h	PF	[XX XX]
		Parameter 5	1	0Ah		
		Parameter 6	1	00h		
		Parameter 7	1	01h		
		Parameter 8	1	33h		
		Parameter 9	1	00h		
		Parameter 10	1	00h		
		Parameter 11	1	33h		
		Parameter 12	1	00h		
		Parameter 13	1	10h		
		Parameter 14	1	32h		
		Parameter 15	1	54h		
		Parameter 16	1	76h		
		Parameter 17	1	10h		
		Parameter 18	1	32h		
		Parameter 19	1	88h		
		Parameter 20	1	88h		
		Parameter 21	1	88h		
		Parameter 22	1	88h		
		Parameter 23	1	88h		
		Parameter 24	1	88h		
		Parameter 25	1	88h		
		Parameter 26	1	99h		
		Parameter 27	1	99h		
		Parameter 28	1	99h		
		Parameter 29	1	54h		
		Parameter 30	1	76h		
		Parameter 31	1	88h		
		Parameter 32	1	88h		

No.	Function	DNC	Command /Parameter	Type	Command/Parameter	
13	SETDGC	Set Digital Gamma Correction setting	0	C1h	PH	[39 80 00 23]
		Parameter 1	1	01h	PD	[C1 01 00 06 0E 16 1E 26 2E 36 3E 46 4E 56 5E 66 6E 76 7E 86 8E 96 9E A6 AE B6 BE C6 CE D6 DE E6 EE F6 FE 00 00 00 00 00 00 00 00 00 03 0B 13 1B 23 2B 33 3B 43 4B 53 5B 63 6B 73 7B 83 8B 93 9B A3 AB B3 BB C3 CB D3 DB E3 EB F3 FB 00 00 00 00 00 00 00 00 00 00 08 10 18 1E 26 2E 36 3E 46 4E 56 5E 66 6E 76 7E 86 8E 96 9E A6 AE B6 BE C6 CE D6 DE E6 ED F5 00 00 00 00 00 00 00 00 00]
		Parameter 2	1	00h		
		Parameter 3	1	06h		
		Parameter 4	1	0Eh		
		Parameter 5	1	16h		
		Parameter 6	1	1Eh		
		Parameter 7	1	26h		
		Parameter 8	1	2Eh		
		Parameter 9	1	36h		
		Parameter 10	1	3Eh		
		Parameter 11	1	46h		
		Parameter 12	1	4Eh		
		Parameter 13	1	56h		
		Parameter 14	1	5Eh		
		Parameter 15	1	66h		
		Parameter 16	1	6Eh	PF	[XX XX]
		Parameter 17	1	76h		
		Parameter 18	1	7Eh		
		Parameter 19	1	86h		
		Parameter 20	1	8Eh		
		Parameter 21	1	96h		
		Parameter 22	1	9Eh		
		Parameter 23	1	A6h		
		Parameter 24	1	AEh		
		Parameter 25	1	B6h		
		Parameter 26	1	BEh		
		Parameter 27	1	C6h		
		Parameter 28	1	CEh		
		Parameter 29	1	D6h		
		Parameter 30	1	DEh		
		Parameter 31	1	E6h		
		Parameter 32	1	EEh		
		Parameter 33	1	F6h		
		Parameter 34	1	FEh		
		Parameter 35	1	00h		
		Parameter 36	1	00h		
		Parameter 37	1	00h		
		Parameter 38	1	00h		
		Parameter 39	1	00h		
		Parameter 40	1	00h		
		Parameter 41	1	00h		
		Parameter 42	1	00h		
		Parameter 43	1	00h		
		Parameter 44	1	00h		
		Parameter 45	1	03h		
		Parameter 46	1	0Bh		
		Parameter 47	1	13h		
		Parameter 48	1	1Bh		
		Parameter 49	1	23h		
		Parameter 50	1	2Bh		
		Parameter 51	1	33h		
		Parameter 52	1	3Bh		
		Parameter 53	1	43h		
		Parameter 54	1	4Bh		
		Parameter 55	1	53h		
		Parameter 56	1	5Bh		
		Parameter 57	1	63h		
		Parameter 58	1	6Bh		
		Parameter 59	1	73h		
		Parameter 60	1	7Bh		
Parameter 61	1	83h				

No.	Function	DNC	Command /Parameter	Type	Command/Parameter
	Parameter 62	1	8Bh		
	Parameter 63	1	93h		
	Parameter 64	1	9Bh		
	Parameter 65	1	A3h		
	Parameter 66	1	ABh		
	Parameter 67	1	B3h		
	Parameter 68	1	BBh		
	Parameter 69	1	C3h		
	Parameter 70	1	CBh		
	Parameter 71	1	D3h		
	Parameter 72	1	DBh		
	Parameter 73	1	E3h		
	Parameter 74	1	EBh		
	Parameter 75	1	F3h		
	Parameter 76	1	FBh		
	Parameter 77	1	00h		
	Parameter 78	1	00h		
	Parameter 79	1	00h		
	Parameter 80	1	00h		
	Parameter 81	1	00h		
	Parameter 82	1	00h		
	Parameter 83	1	00h		
	Parameter 84	1	00h		
	Parameter 85	1	00h		
	Parameter 86	1	00h		
	Parameter 87	1	00h		
	Parameter 88	1	08h		
	Parameter 89	1	10h		
	Parameter 90	1	18h		
	Parameter 91	1	1Eh		
	Parameter 92	1	26h		
	Parameter 93	1	2Eh		
	Parameter 94	1	36h		
	Parameter 95	1	3Eh		
	Parameter 96	1	46h		
	Parameter 97	1	4Eh		
	Parameter 98	1	56h		
	Parameter 99	1	5Eh		
	Parameter 100	1	66h		
	Parameter 101	1	6Eh		
	Parameter 102	1	76h		
	Parameter 103	1	7Eh		
	Parameter 104	1	86h		
	Parameter 105	1	8Eh		
	Parameter 106	1	96h		
	Parameter 107	1	9Eh		
	Parameter 108	1	A6h		
	Parameter 109	1	AEh		
	Parameter 110	1	B6h		
	Parameter 111	1	BEh		
	Parameter 112	1	C6h		
	Parameter 113	1	CEh		
	Parameter 114	1	D6h		
	Parameter 115	1	DEh		
	Parameter 116	1	E6h		
	Parameter 117	1	EDh		
	Parameter 118	1	F5h		
	Parameter 119	1	00h		
	Parameter 120	1	00h		
	Parameter 121	1	00h		
	Parameter 122	1	00h		
	Parameter 123	1	00h		
	Parameter 124	1	00h		
	Parameter 125	1	00h		
	Parameter 126	1	00h		
	Parameter 127	1	00h		

No.		Function	DNC	Command /Parameter	Type	Command/Parameter
14	SETGAMMA	Set gamma curve related setting	0	E0h	PH	[39 2B 00 05]
		Parameter 1	1	00h	PD	[E0 00 00 00 12 1D 34 13 2A 04 0C 12 16 19 16 16 0E 11 00 00 00 18 24 3F 16 2C 04 0D 10 16 18 16 16 10 11 07 16 06 0F 08 16 07 10]
		Parameter 2	1	00h		
		Parameter 3	1	00h		
		Parameter 4	1	12h	PF	[XX XX]
		Parameter 5	1	1Dh		
		Parameter 6	1	34h		
		Parameter 7	1	13h		
		Parameter 8	1	2Ah		
		Parameter 9	1	04h		
		Parameter 10	1	0Ch		
		Parameter 11	1	12h		
		Parameter 12	1	16h		
		Parameter 13	1	19h		
		Parameter 14	1	16h		
		Parameter 15	1	16h		
		Parameter 16	1	0Eh		
		Parameter 17	1	11h		
		Parameter 18	1	00h		
		Parameter 19	1	00h		
		Parameter 20	1	00h		
		Parameter 21	1	18h		
		Parameter 22	1	24h		
		Parameter 23	1	3Fh		
		Parameter 24	1	16h		
		Parameter 25	1	2Ch		
		Parameter 26	1	04h		
		Parameter 27	1	0Dh		
		Parameter 28	1	10h		
		Parameter 29	1	16h		
		Parameter 30	1	18h		
		Parameter 31	1	16h		
		Parameter 32	1	16h		
		Parameter 33	1	10h		
		Parameter 34	1	11h		
		Parameter 35	1	07h		
		Parameter 36	1	16h		
		Parameter 37	1	06h		
		Parameter 38	1	0Fh		
		Parameter 39	1	08h		
		Parameter 40	1	16h		
		Parameter 41	1	07h		
Parameter 42	1	10h				
15	SETCABC	Set CABC Control (PWM=35kHz)	0	C9h	PH	[39 0A 00 36]
		Parameter 1	1	0Fh	PD	[C9 0F 00 1E 1E 00 00 00 01 3E]
		Parameter 2	1	00h		
		Parameter 3	1	1Eh		
		Parameter 4	1	1Eh	PF	[XX XX]
		Parameter 5	1	00h		
		Parameter 6	1	00h		
		Parameter 7	1	00h		
		Parameter 8	1	01h		
Parameter 9	1	3Eh				
16	WRDISBV	Write display brightness Parameter 1(255/255)	0 1	51h Fh	PH	[15 51 FF 3C]
17	WRCTRLD	Write CTRL display(PWM OFF) Parameter 1	0 1	53h 00h	PH	[15 53 00 13]
18	SETVDC	SETVDC	0	BCh	PH	[15 BC 07 0B]
		Parameter 1	1	07h		
	Wait	wait 5 msec or more				
19	SETPANEL	Set panel	0	CCh	PH	[15 CC 09 10]
		Parameter 1	1	09h		
	Wait	wait 50 msec or more				
20	SETMIPI	Set MIPI control	0	BAh	PH	[15 BA 03 00]
		Parameter 1( 4 lane)	1	03h		
21	SLEEP OUT	Sleep out	0	11h	PH	[05 11 00 36]
		Wait				
22	DISPON	Display on	1	29h	PH	[05 29 00 1C]
		Wait				
23	Video stream					



PH :Packet Header  
PD :Packet Data  
PF:Packet Footer (=Checksum)

8.2 Power-OFF Sequence

No.		Function	DNC	Command /Parameter	Type	Command/Parameter
1	DISPOFF	Display off	0	28h	PH	[05 28 00 06]
2	SLPIN	Sleep in	0	10h	PH	[05 10 00 2C]
	Wait	wait 120 msec or more				
3	Video signals	Video signals stop				

Power off

8.3 Sleep Sequence

No.		Function	DNC	Command /Parameter	Type	Command/Parameter
1	SLPIN	Sleep in	0	10h	PH	[05 10 00 2C]
	Wait	wait 120 msec or more				
2	Video signals	Video signals stop				

8.4 Sleep Release Sequence

No.		Function	DNC	Command /Parameter	Type	Command/Parameter
1	Video signals	Video signals start				
	Wait	wait 120 msec or more				
2	SLPOUT	Sleep out	0	11h	PH	[05 11 00 36]

8.5 ULPS (Ultra-low power state) Enter/Exit Sequence

Lane	Mode	Sequence
D0P,D0N	Enter ULPS	LP11 → LP10 → LP00 → LP01 → LP00 → (78h) → LP00(ULPS)
	Exit ULPS	LP10 (keeps for at least 1 ms) → LP11
CP,CN	Enter ULPS	LP11 → LP10 → LP00(ULPS)
	Exit ULPS	LP10 (keeps for at least 1 ms) → LP11

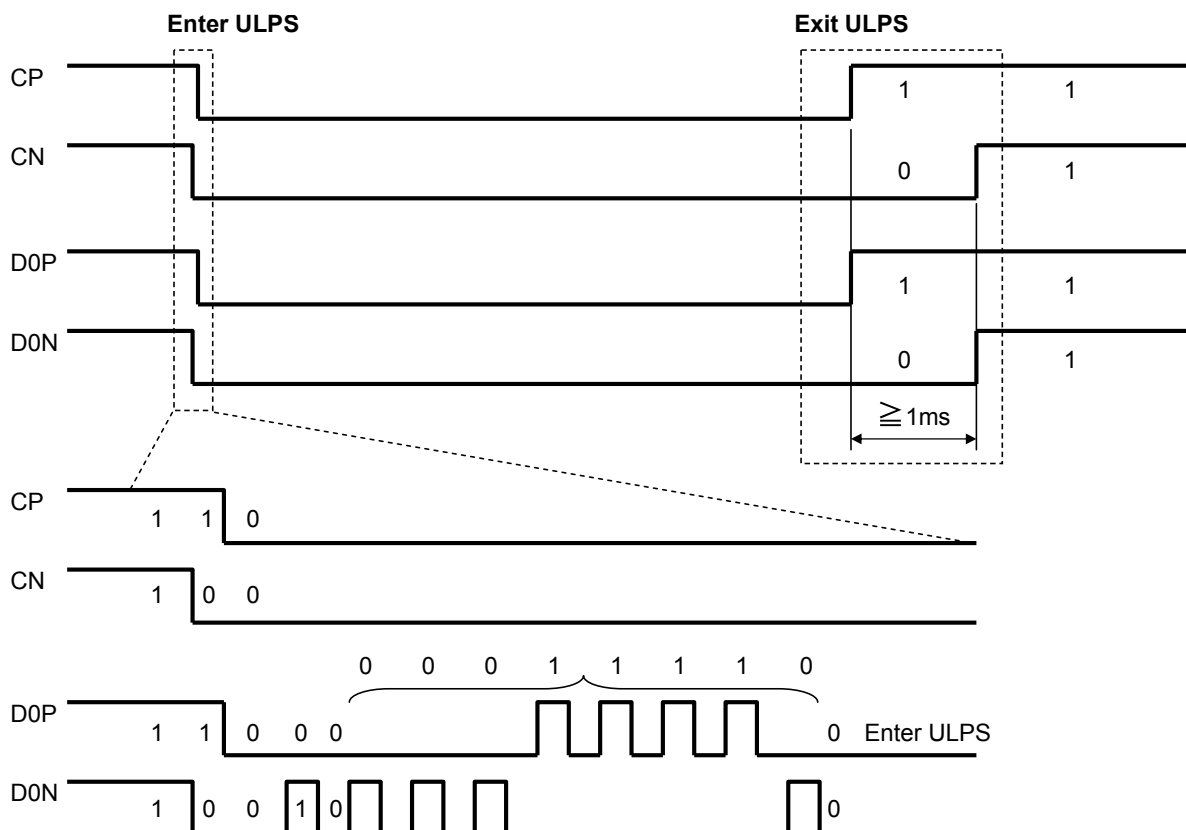

**9.Absolute Maximum Ratings**

Item	Symbol	Condition	Rating		Unit	Terminal
			MIN	MAX		
Power supply voltage	VCC		-0.3	4.4	V	VCC
IO logic voltage	IOVCC		-0.3	3.6	V	IOVCC
Input voltage	VI		-0.3	IOVCC+0.3	V	RESX
DSI Input voltage	VDSIIN		-0.15	1.45	V	D0P,D0N,D1P,D1N,D2P,D2N,D3P,D3N,CP,CN
LED current	ILED	Ta=25°C	-	35	mA	LED+,LED-
		Ta=70°C	-	15		
Storage temperature	Tstg		-30	+80	°C	

**10.Recommended Operating Conditions**

Item	Symbol	Condition	Rating			Unit	Terminals
			MIN	TYP	MAX		
Supply voltage	VCC		2.8	2.9	3.0	V	VCC
IO logic voltage	IOVCC		1.8	1.9	2.0	V	IOVCC
LED current	ILED	Ta=25°C	—	10	—	mA	LED+,LED-
LED Forward voltage *1	VL	Ta=25°C ILED=10mA	—	24.8	27.5	V	LED+,LED-
Estimated Life of LED , Note	LL	Ta=25°C ILED=10mA	—	20000	—	hr	
Operation temperature	Top		-20	+25	+70	°C	Temperature at the surface of the display

\*1 Reference value

Note:

- The lifetime of the LED is defined as a period till the brightness of the LED decreases to the half of its initial value.
- This figure is given as a reference purpose only, and not as a guarantee.
- This figure is estimated for an LED operating alone.
- As the performance of an LED may differ when assembled as a set together with a TFT panel due to different environmental temperature.
- Estimated lifetime could vary on a different temperature and usually higher temperature could reduce the life significantly.
- This monitor is operatable in this temperature range. With regard to optical characteristics, refer to Item 13."CHARACTERISTICS".
- Acceptable Forward Current to LED is up to 15 mA, when Ta=+70 °C. Do not exceed Allowable Forward Current shown on the chart.

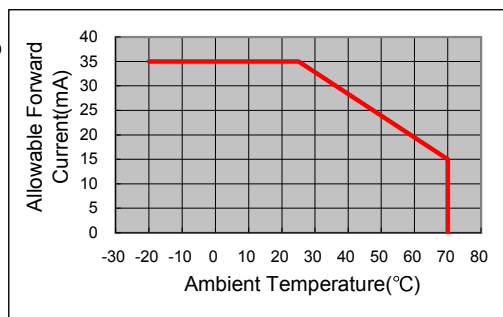

**11.Electrical Characteristics**

**11.1 DC Characteristics**

**11.1.1 DC Characteristics**

If no conditions are specified, then VCC=2.9V,IOVCC=1.9V, Ta=25°C.

Items	Symbol	Condition	Rating			Unit	Terminals
			MIN	TYP	MAX		
High level input voltage	VIH1		0.8IOVCC		IOVCC	V	RESX
Low level input voltage	VIL1		0		0.2IOVCC	V	
Current Consumption	ICC1	Normal ,Still image *		27	54	mA	VCC
	ICC2	Sleep IN		75	200	uA	
	ICC3	ULPS		10	20	uA	
	IOICC1	Normal ,Still image *		15	24	mA	IOVCC
	IOICC2	Sleep IN		25	100	uA	
	IOICC3	ULPS		7	30	uA	

\* A still image (color bar) on display , when accessing to the driver by MIPI DSI 4Lane.

The details of the drive condition of MIPI DSI are referring to the following.

Vsync pulse width	3	line	Hsync pulse width	15	clk	Frame Rate	58.1	Hz
V-Back porch	3	line	H-Back porch	70	clk	Data Rate	403.2	Mbps
V-Front portch	6	line	H-Front portch	91	clk	CLK frequency	201.6	MHz
V-Line	1280	line	H-Line	720	clk			

**11.1.2 MIPI DSI D-PHY DC Characteristics** (Unless otherwise noted, Ta=25 °C, VDD=2.9V, VCCIO=1.9V, GND=0V)

Item	Symbol	Condition	Rating			Unit	Note
			MIN	TYP	MAX		
LP-TX	Thevenin output low level	VOL	-50	-	50	mV	
	Thevenin output high level	VOH	1.1	1.2	1.3	V	
	Output impedance of LP transmitter	ZOLP	110	-	-	Ohm	
HS-RX	Differential input high threshold	VIDTH	-	-	70	mV	
	Differential input low threshold	VIDTL	-70	-	-	mV	
	Single-ended input low voltage	VILHS	-40	-	-	mV	
	Single-ended input high voltage	VIHHS	-	-	460	mV	
	Common-mode voltage HS receive mode	VCMRXDC	70	-	330	mV	
	Differential input impedance	ZID	80	100	125	Ohm	
LP-RX	Logic 0 input voltage	VIL	-	-	550	mV	
	Logic 1 input voltage	VIH	880	-	-	mV	
CD-RX	Logic 1 contention threshold	VIHCD	450	-	-	mV	
	Logic 0 contention threshold	VILCD	-	-	200	mV	

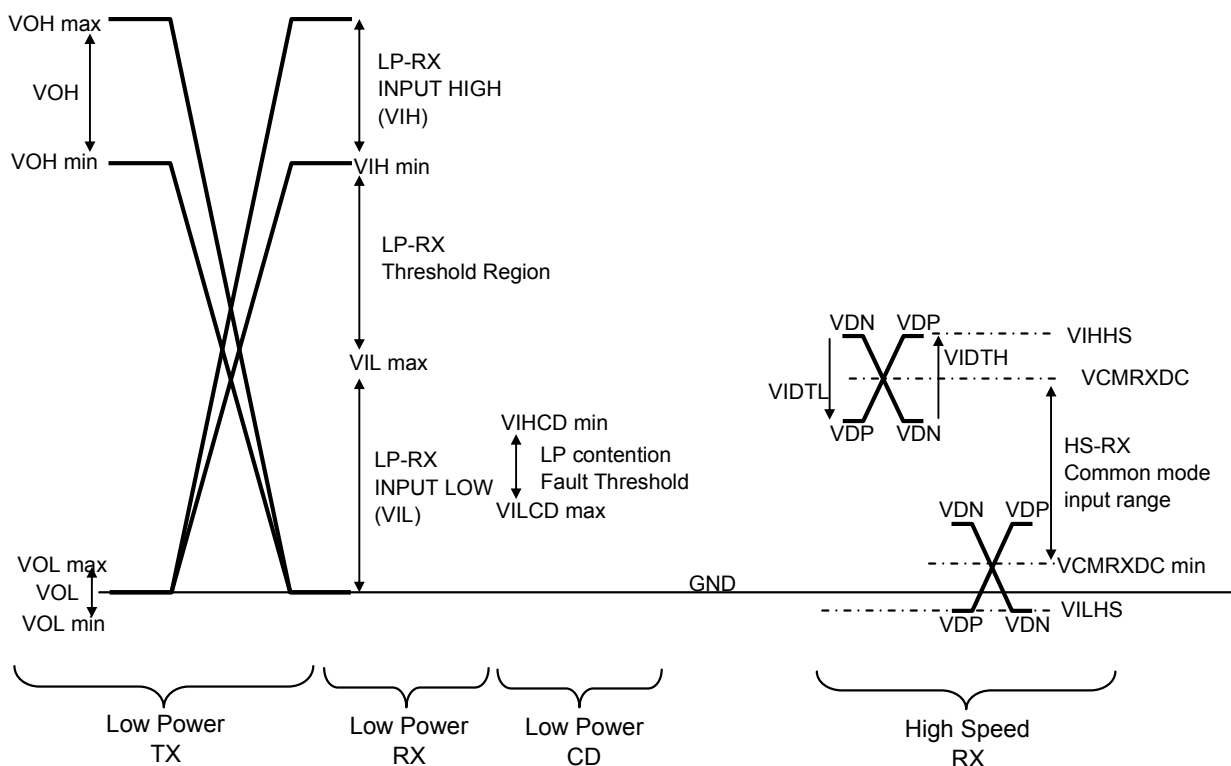

Fig. A The signal levels for the LP and HS .

## 11.2 AC Characteristics

### 11.2.1 HS-RX Specifications

(Unless otherwise noted,  $T_a=25\text{ }^\circ\text{C}$ ,  $V_{DD}=2.9\text{V}$ ,  $V_{CCIO}=1.9\text{V}$ ,  $GND=0\text{V}$ )

Item	Symbol	Condition	Rating			Unit	Applicable terminal
			MIN	TYP	MAX		
DSICLK Cycle time	TCLKP	Fig.B	4	-	25.0	ns	CP,CN
DSICLK Frequency	f DSICLK		40	-	250	MHz	
DSI Data Transfer Rate	UI		2	-	12.5	ns	D0P,D0N , D1P,D1N
	t DSIR		80	-	500	Mbps	D2P,D2N , D3P,D3N
Data to Clock Setup Time	Tsetup		0.15	-	-	UI	D0P,D0N , D1P,D1N D2P,D2N , D3P,D3N
Clock to Data Hold Time	Thold	0.15	-	-	UI	CP,CN	

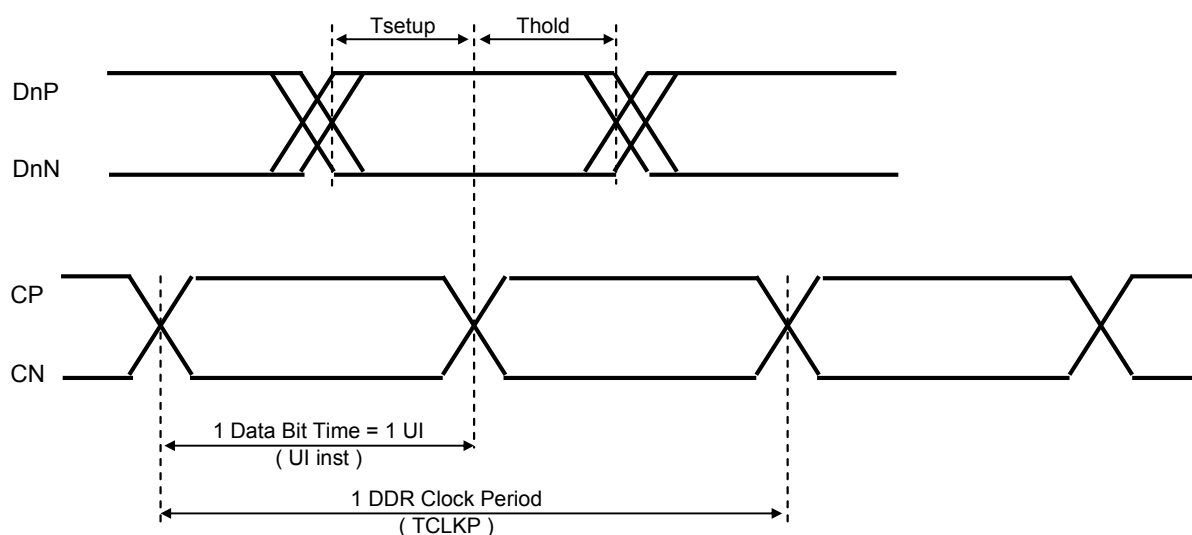

Fig.B Data to Clock Timing Definitions

### 11.2.2 LP-TX Specifications

(Unless otherwise noted,  $T_a=25\text{ }^\circ\text{C}$ ,  $V_{DD}=2.9\text{V}$ ,  $V_{CCIO}=1.9\text{V}$ ,  $GND=0\text{V}$ )

Item	Symbol	Condition	Rating			Unit	Applicable terminal
			MIN	TYP	MAX		
15% - 85% rise time	TRLP		-	-	25	ns	D0P,D0N
85% - 15% fall time	TFLP		-	-	25	ns	
Slew rate	$\Delta v / \Delta t_{SR}$	Clload = 0pF	-	-	500	mV/ns	
		Clload = 5pF	-	-	300	mV/ns	
		Clload = 20pF	-	-	250	mV/ns	
		Clload = 70pF	-	-	150	mV/ns	
		Clload = 0 to 70pF (Falling Edge)	30	-	-	mV/ns	
		Clload = 0 to 70pF (Rising Edge)	30	-	-	mV/ns	
Load capacitance	CLOAD	Clload = 0 to 70pF (Rising Edge) (VO,INST-700)	0	-	70	pF	

11.3 MIPI DSI Input Timing Characteristics

Item	Symbol	Condition	Rating			Unit	Remark
			MIN	TYP	MAX		
VSYNC Frequency	fVSYNC	Fig. C	54	58.1	66	Hz	D0P,D0N , D1P,D1N, D2P,D2N , D3P,D3N, CP,CN
VSYNC Pulse Width	VS		3	3	-	line	
Vertical Back Porch	VBP		3	3	-	line	
Vertical Front Porch	VFP		6	6	-	line	
Vertical Display Period	VDISP		-	1280	-	line	
HSYNC Pulse Width	HS	Fig. C	-	15	-	clk	
Horizontal Back Porch	HBP		-	70	-	clk	
Horizontal Front Porch	HFP		-	91	-	clk	
Horizontal Display Period	HDISP		-	720	-	clk	
Minimum HS time	tHS	Fig. C	0.2	-	-	us	
Minimum HBP time	tHBP		1	-	-	us	
Minimum HFP time	tHFP		1	-	-	us	
Minimum HS + FHP + HBP time	t(HS+HBP+HFP)		2.2	-	-	us	

Note: This is recommended spec to get high quality picture on display. It is customer's risk to use out of this frequency.

Vertical timing

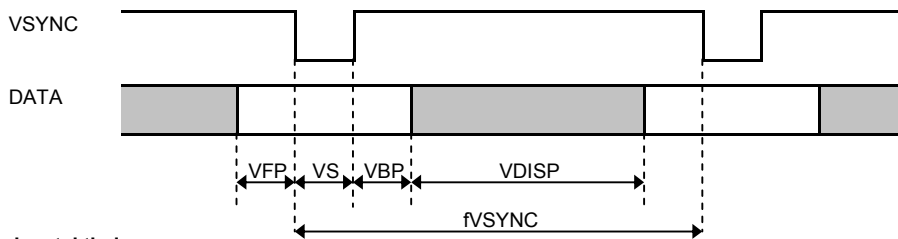

Horizontal timing

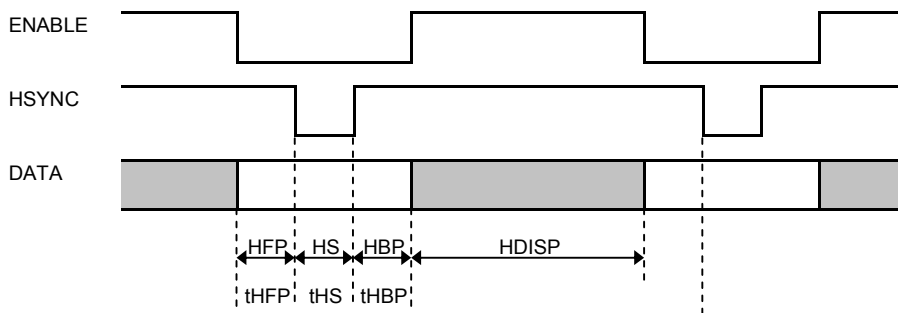

Fig.C Vertical ,Horizontal timing

11.4 Reset input timing

Item	Symbol	Condition	Rating			Unit	Remark
			MIN	TYP	MAX		
Reset Low Pulse width	tRESW		20	-	-	us	RESX
Reset Complete time	tREST	during Sleep In	10	-	-	ms	
		during Sleep Out	120	-	-	ms	

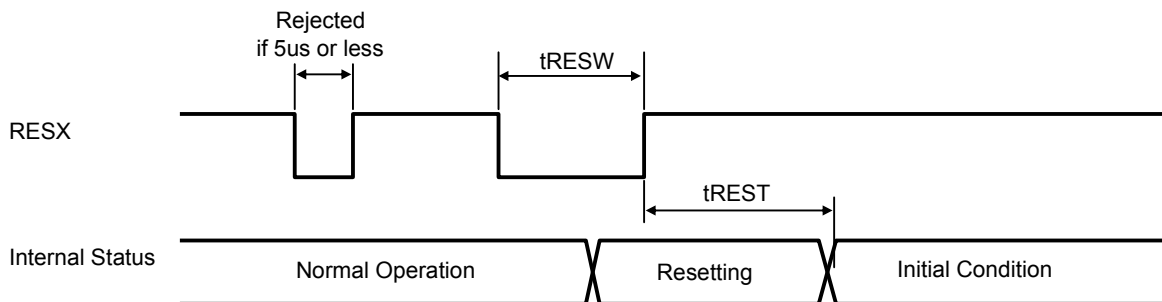

Fig.D RESX input timing

### 12.External Power on/off Sequence

VCC and IOVCC can be applied in any order.  
VCC and IOVCC can be powered down in any order.



Case 1. RESX line is held high or unstable by host at power on

If RESX line is held high or unstable by the host during power on, then a Hardware Reset must be applied after both IOVCC and VCC have been applied-otherwise correct functionality is not guaranteed. There is no timing restriction upon this hardware reset. And, before the rising edge of RESX, must be set to LP-11 all lanes of MIPI.

Case1 Power ON

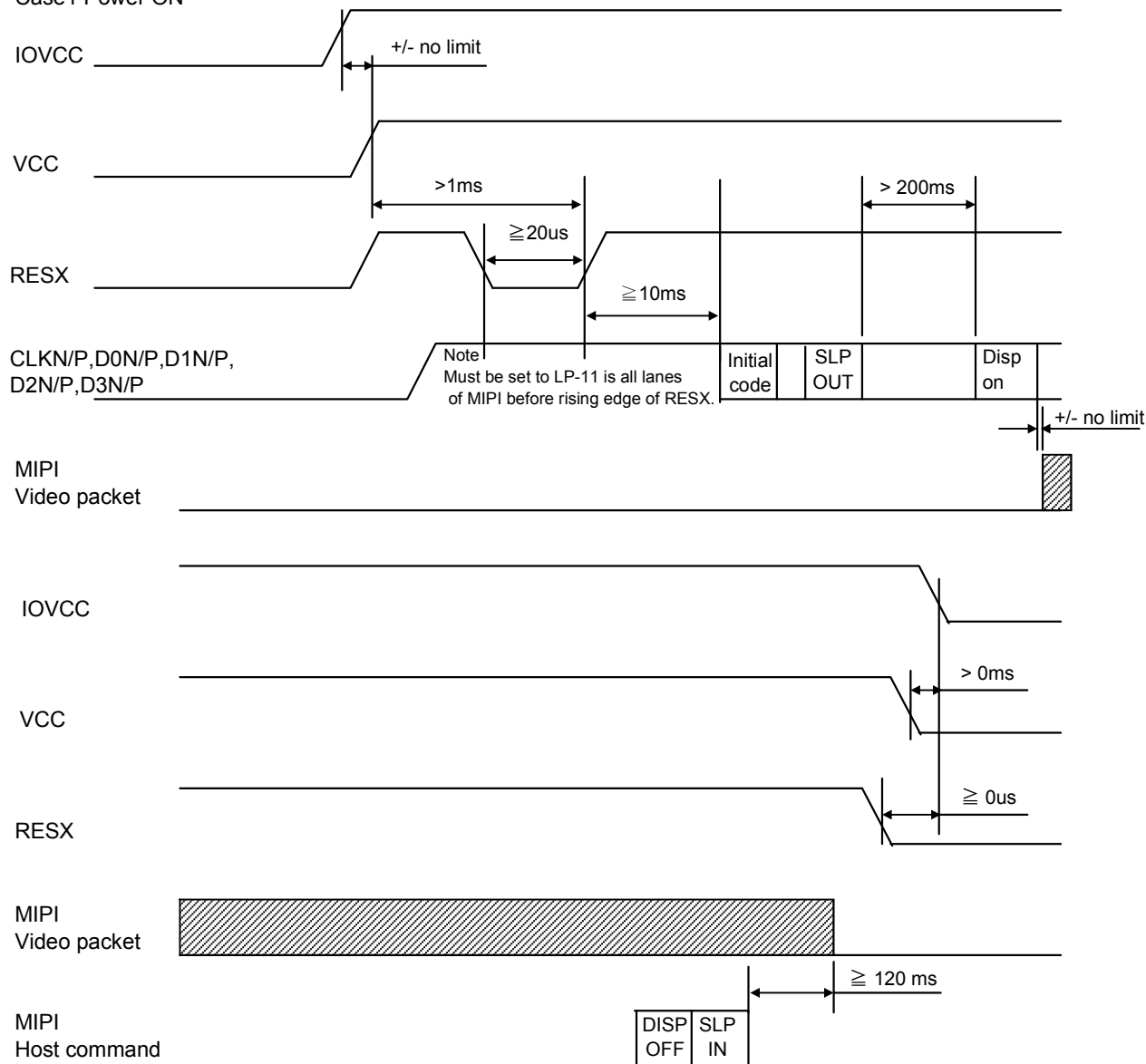

Case 2. RESX line is held low by host at power on



If RESX line is held low (and stable) by the host during power on, then the RESX must be low for minimum 1 msec after both IOVCC and VCC have been applied. And, before the rising edge of RESX, must be set to LP-11 all lanes of MIPI.

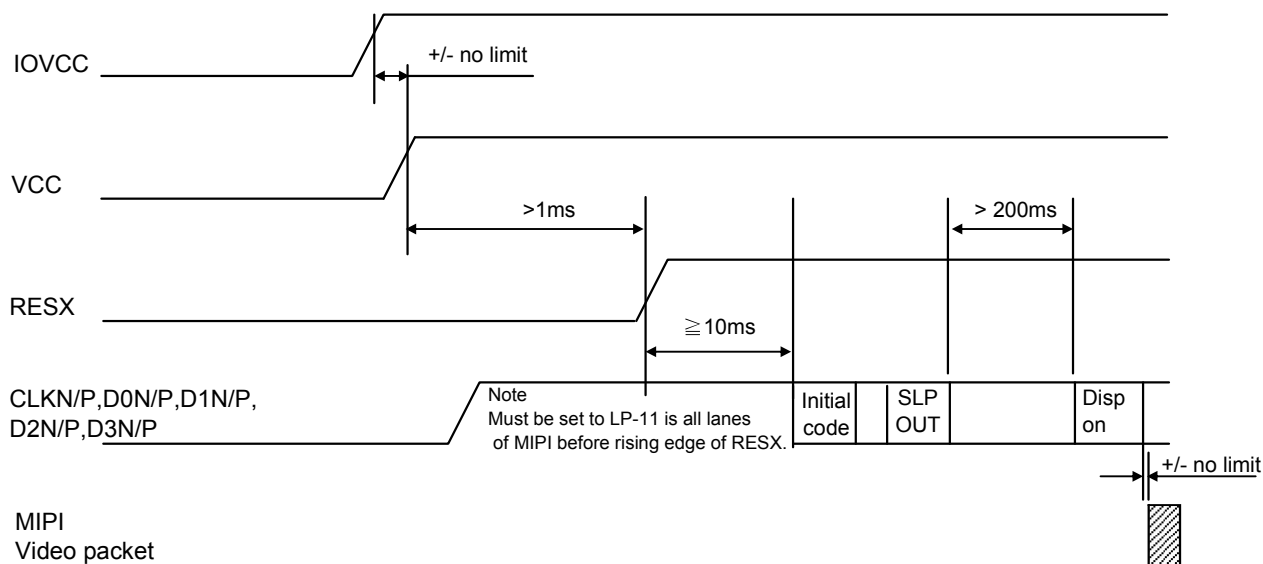

Case2 Power OFF

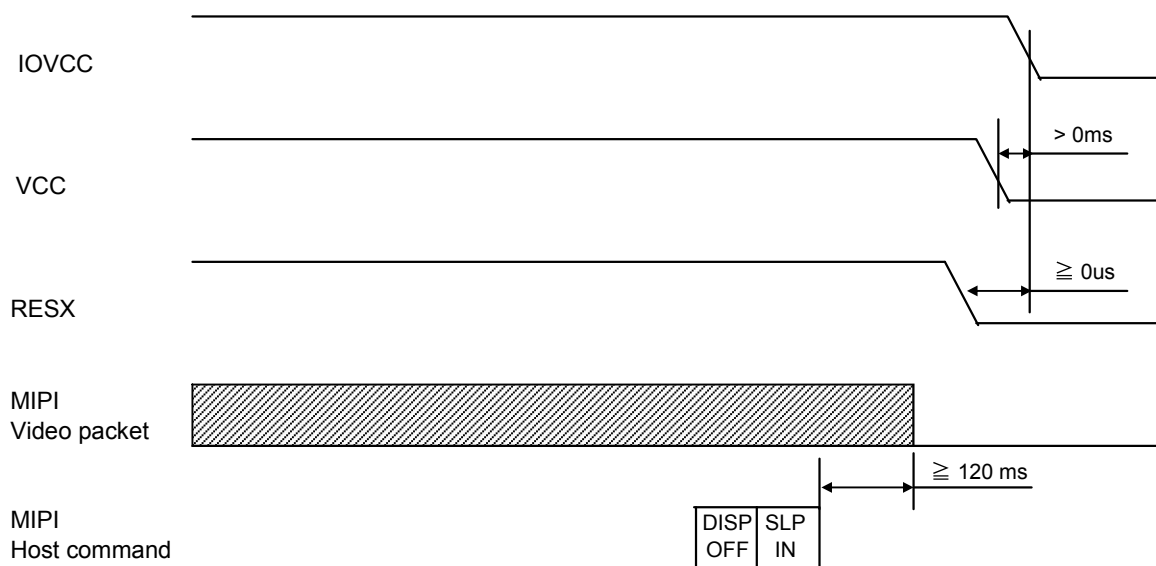

## 13. Characteristics

## 13.1 Optical Characteristics

&lt; Measurement Condition &gt;

Measuring instruments: CS1000 (KONICA MINOLTA) , LCD7200(OTSUKA ELECTRONICS) ,  
EZcontrast160D(ELDIM)

Driving condition: VCC=2.9V, IOVCC=1.9V, GND=0V  
Optimized VCOMDC

Backlight: IL=10.0mA

Measured temperature: Ta=25° C

Item	Symbol	Condition	MIN	TYP	MAX	Unit	Note No.	Remark	
Response time	Rise time	TON	[Data]= 00h→FFh	—	—	40	ms	1	
	Fall time	TOFF	[Data]= FFh→00h	—	—	60	ms		
Contrast ratio	Backlight ON	CR	[Data]= FFh / 00h	350	700	—		2	
	Backlight OFF			—	3.0	—			
Viewing angle	Left	θL	[Data]= FFh / 00h CR ≥ 10	80	—	—	deg	3	
	Right	θR		80	—	—	deg		
	Up	φU		80	—	—	deg		
	Down	φD		80	—	—	deg		
White Chromaticity	x	[Data]=FFh	White chromaticity range					4	
	y								
Burn-in			No noticeable burn-in image shall be observed after 2 hours of window pattern display.				5		
Center brightness		[Data]=FFh	210	300	—	cd/m <sup>2</sup>	6		
Brightness distribution		[Data]=FFh	70	—	—	%	7		

\* Note number 1 to 7: Refer to the APPENDIX of "Reference Method for Measuring Optical Characteristics".



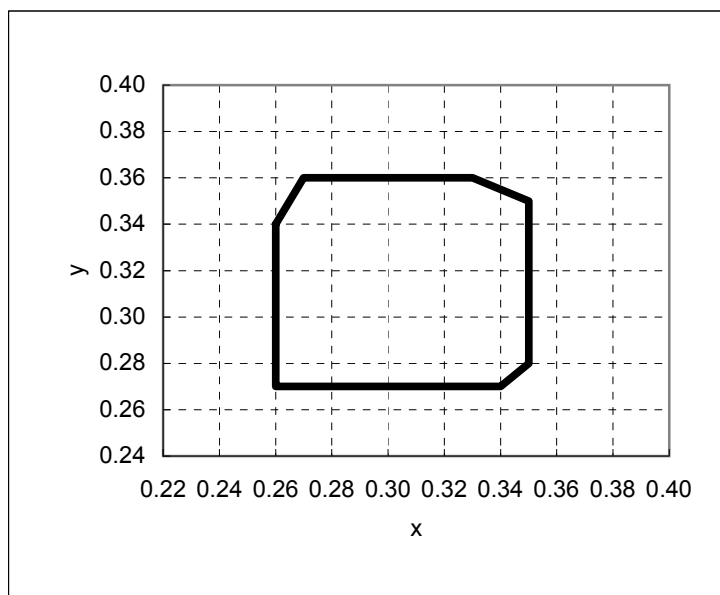

White Chromaticity Range

【White Chromaticity Range】

x	y
0.26	0.34
0.26	0.27
0.34	0.27
0.35	0.28
0.35	0.35
0.33	0.36
0.27	0.36

### 13.2 Temperature Characteristics

< Measurement Condition >

Measuring instruments: CS1000 (KONICA MINOLTA) , LCD7200(OTSUKA ELECTRONICS)

Driving condition: VCC=2.9V, IOVCC=1.9V, GND=0V

Optimized VCOMDC

Backlight: IL=10.0mA

Item			Specification		Remark
			Ta = -10° C	Ta = 70° C	
Contrast ratio		CR	40 or more	40 or more	Backlight ON
Response time	Rise time	TON	300 msec or less	30 msec or less	
	Fall time	TOFF	300 msec or less	50 msec or less	
Display Quality			No noticeable display defect or nonuniformity should be observed.		

## 14. Criteria of Judgment

## 14.1 Defective Display and Screen Quality

Test Condition:	Observed TFT-LCD monitor from front during operation with the following conditions
Driving Signal	Raster Patter (RGB, white, black)
Signal condition	[Data]:00h, A8h, FFh (3steps)
Observation distance	30 cm
Illuminance	200 to 350 lx
Backlight	IL=10.0mA

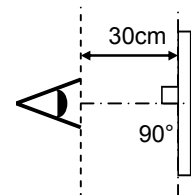

Defect item	Defect content	Criteria		
Display Quality	Line defect	Black, white or color line, 3 or more neighboring defective dots		
	Dot defect	Uneven brightness on dot-by-dot base due to defective TFT or CF, or dust is counted as dot defect (brighter dot, darker dot) High bright dot: Visible through 2% ND filter at [Data]=00h Low bright dot: Visible through 5% ND filter at [Data]=00h Dark dot: Appear dark through white display at [Data]=A8h Invisible through 5% ND filter at [Data]=00h		
	Dirt	Uneven brightness (white stain, black stain etc)		
Screen Quality	Foreign particle	Point-like	0.25mm < $\phi$	N=0
		Liner	0.20mm < $\phi \leq 0.25$ mm	$N \leq 2$
			$\phi \leq 0.20$ mm	Acceptable
	Others	3.0mm < length and 0.08mm < width	N=0	
		length $\leq 3.0$ mm or width $\leq 0.08$ mm	Acceptable	
		Use boundary sample for judgment when necessary		

$\phi$ (mm): Average diameter = (major axis + minor axis)/2  
Permissible number: N

Table 1

Area	High bright dot	Low bright dot	Dark dot	Total	Criteria
A	0	2	2	3	Permissible distance between same color bright dots (includes neighboring dots): 3 mm or more
B	2	4	4	6	Permissible distance between same color high bright dots (includes neighboring dots): 5 mm or more
Total	2	4	4	7	

&lt;Portrait model&gt;

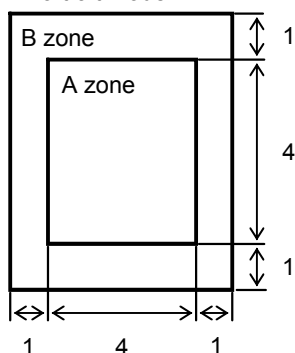

Division of A and B areas

B area: Active area

Dimensional ratio between A and B areas: 1: 4: 1

(Refer to the left figure)

## 14.2 Screen and Other Appearance

## Testing conditions

Observation distance	30cm
Illuminance	1200~2000 lx

Item	Criteria	Remark
Polarizer Flaw Stain Bubble Dust Dent	Ignore invisible defect when the backlight is on.	Outside of active area: Disregard.  (Refer to the section 3.3 "Outward form")
S-case	No functional defect occurs	
FPC cable	No functional defect occurs	

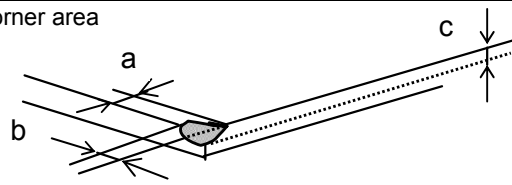
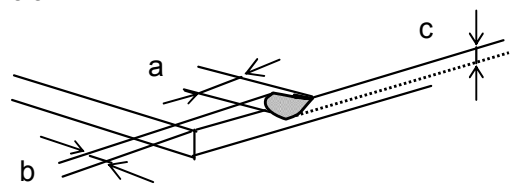
Item	Appearance	Criteria
Glass chipping	Corner area 	Unit:mm $a \leq 3$ $b \leq 3$ $c \leq t$ (t: glass thickness) $a, b \leq 0.5$ is acceptable
	Others 	Unit:mm $a \leq 5$ $b \leq 1$ $c \leq t$ (t:glass thickness) $a, b \leq 0.5$ is acceptable Maximum permissible number of chipping off on a side is 5.
	Progressive crack	None

## 15. Reliability Test

Test item		Test condition		number of failures /number of examinations
Durability test	High temperature storage	Ta=80° C	240hrs	0 / 3
	Low temperature storage	Ta=-30° C	240hrs	0 / 3
	High temperature & high humidity storage	Ta=60° C, RH=90% non condensing	240hrs	0 / 3
	High temperature operation	Tp=70° C	240hrs	0 / 3
	Low temperature operation	Tp=-20° C	240hrs	0 / 3
	High temp & humid operation	Tp=40° C, RH=90% non condensing	240hrs	0 / 3
	Thermal shock storage	-30←→80° C(30min/30min)	100 cycles	0 / 3
Mechanical environmental test	Electrostatic discharge test (Non operation)	Confirms to EIAJ ED-4701/300 C=200pF,R=0Ω,V=±200V Each 3 times of discharge on and power supply and other terminals.		0 / 3
	Surface discharge test (Non operation)	C=250pF, R=100Ω, V=±8kV Each 5 times of discharge in both polarities on the center of screen with the case grounded.		0 / 3
	Vibration test	Total amplitude 1.5mm, f=10~55Hz, X,Y,Z directions for each 2 hours		0 / 3
	Impact test	Use ORTUS TECHNOLOGY original jig (see next page)and make an impact with peak acceleration of 1000m/s <sup>2</sup> for 6 msec with half sine-curve at 3 times to each X, Y, Z directions in conformance with JIS C 60068-2-27-2011.		0 / 3
Packing test	Packing vibration-proof test	Acceleration of 19.6m/s <sup>2</sup> with frequency of 10→55→10Hz, X,Y, Zdirection for each 30 minutes		0 / 1 packing
	Packing drop test	Drop from 75cm high. 1 time to each 6 surfaces, 3 edges, 1 corner		0 / 1 packing

Note: Ta=ambient temperature    Tp=Panel temperature

※ The profile of high temperature/humidity storage and High Temperature/humidity operation  
(Pure water of over 10MΩ·cm shall be used.)

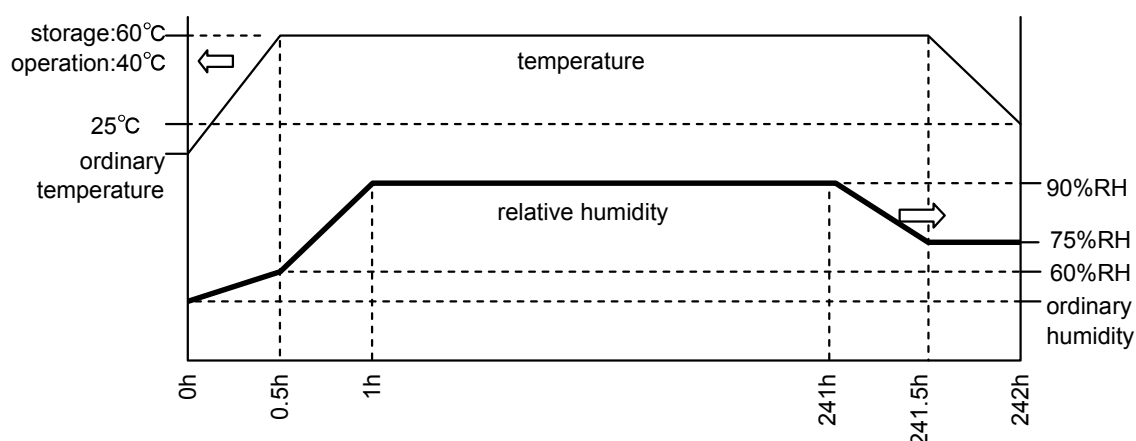
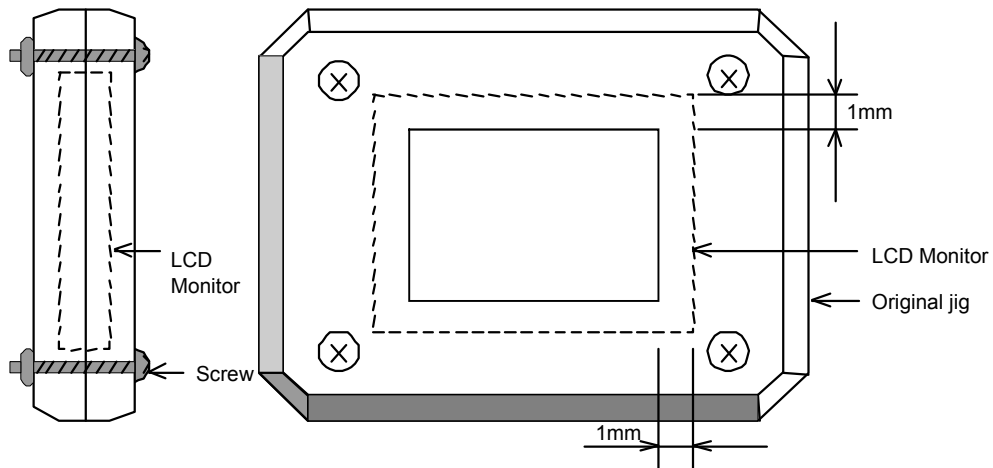

Table2.Reliability Criteria

The parameters should be measured after leaving the monitor at the ordinary temperature for 24 hours or more after the test completion.

item	Standard	Remarks
Display quality	No visible abnormality shall be seen.	
Contrast ratio	40 or more	Backlight ON

ORTUS TECHNOLOGY Original Jig



## 16. Packing Specifications

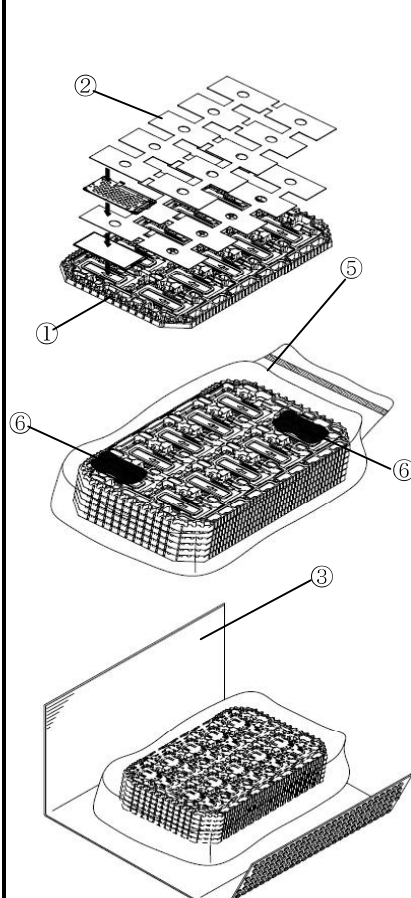

Step 1. Each product is to be placed in one of the cut-outs of the tray with its LCD display side facing upward, and foam-sheet is put on products.  
( 10 pieces / 1 step )

Each product is to be placed on the FOAM SHEET with its LCD display side facing downward, and foam-sheet is put on products.  
( 20 pieces / tray )

Step 2. Each tray filled with products is to be piled up in stack of 5.  
One empty tray is to be put on the stack of 5 trays.

Step 3. 2 packs of moisture absorbers are to be placed on the top tray as shown in the drawing.  
Put piled trays into a sealing bag.

Step 4. Vacuum and seal the sealing bag with the vacuum sealing machine.

Step 5. The piled trays are to be wrapped with a bubble cushioning sheet, and to be fixed with adhesive tape.

Step 6. A corrugated board is to be placed in the bottom of an outer carton.  
The wrapped trays are to be put on the corrugated board in the outer carton.  
Another corrugated board is to be placed on the top of the inserted carton box.

Step 7. The outer carton is to be sealed in H-shape with packing tape as shown in the drawing.  
The model number, quantity of products, and shipping date are to be printed on the 2 opposite sides of the outer carton with black ink.  
If necessary, shipping labels or impression markings are to be put on the outer carton.

Step 8. The outer carton is to be inserted into an extra outer carton with same orientation.

Step 9. The extra outer carton is to be sealed with in H-shape with packing tape as shown in the drawing.  
The model number, quantity of products, and shipping date are to be printed on the 2 opposite sides of the extra outer carton with black ink.  
If necessary, shipping labels or impression markings are to be put on the extra outer carton.

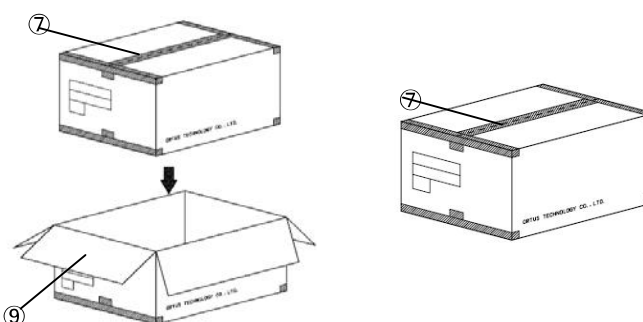
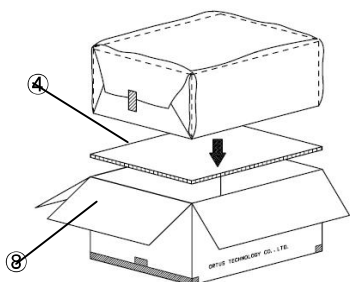

\* Maximum piling up: 8 cartons

Remark: The return of packing materials is not required.

Packing item name		Specs., Material
①	TRAY	A-PET (Antistatic)
②	FOAM SHEET	Antistatic Polyethylene
③	B SHEET A	Antistatic air bubble sheet
④	INNER BOARD	Corrugated cardboard
⑤	SEALING BAG	
⑥	DRIER	Moisture absorber
⑦	PACKING TAPE	
⑧	OUTER CARTON	Corrugated cardboard
⑨	EXTRA OUTER CARTON	Corrugated cardboard

Dimension of extra outer carton	
D : Approx.	337mm
W : Approx.	618mm
H : Approx.	179mm
Quantity of products packed in one carton: 100	
Gross weight : Approx.	5.7 kg

## 17. Handling Instruction

## 17.1 Cautions for Handling LCD panels

**Caution**

- (1) Do not make an impact on the LCD panel glass because it may break and you may get injured from it.
- (2) If the glass breaks, do not touch it with bare hands.  
(Fragment of broken glass may stick you or you cut yourself on it.)
- (3) If you get injured, receive adequate first aid and consult a medial doctor.
- (4) Do not let liquid crystal get into your mouth.  
(If the LCD panel glass breaks, try not let liquid crystal get into your mouth even toxic property of liquid crystal has not been confirmed.)
- (5) If liquid crystal adheres, rinse it out thoroughly.  
(If liquid crystal adheres to your cloth or skin, wipe it off with rubbing alcohol or wash it thoroughly with soap. If liquid crystal gets into eyes, rinse it with clean water for at least 15 minutes and consult an eye doctor.)
- (6) If you scrap this products, follow a disposal standard of industrial waste that is legally valid in the community, country or territory where you reside.
- (7) Do not connect or disconnect this product while its application products is powered on.
- (8) Do not attempt to disassemble or modify this product as it is precision component.
- (9) If a part of soldering part has been exposed, and avoid contact (short-circuit) with a metallic part of the case etc. about FPC of this model, please.  
Please insulate it with the insulating tape etc. if necessary.  
The defective operation is caused, and there is a possibility to generation of heat and the ignition.
- (10) Since excess current protection circuit is not built in this TFT module, there is the possibility that LCD module or peripheral circuit become feverish and burned in case abnormal operation is generated.  
We recommend you to add excess current protection circuit to power supply.
- (11) The devices on the FPC are damageable to electrostatic discharge, because the terminals of the devices are exposed.  
Wear grounded wrist-straps and use electrostatic neutralization blowers to prevent static charge and discharge when handling the TFT monitors.  
Designate an appropriate operating area, and set equipment, tools, and machines properly when handling this product.



**Caution** This mark is used to indicate a precaution or an instruction which, if not correctly observed, may result in bodily injury, or material damages alone.

## 17.2 Precautions for Handling

- 1) Wear finger tips at incoming inspection and for handling the TFT monitors to keep display quality and keep the working area clean.  
Do not touch the surface of the monitor as it is easily scratched.
- 2) Wear grounded wrist-straps and use electrostatic neutralization blowers to prevent static charge and discharge when handling the TFT monitors as the LED in this TFT monitors is damageable to electrostatic discharge.  
Designate an appropriate operating area, and set equipment, tools, and machines properly when handling this product.
- 3) Avoid strong mechanical shock including knocking, hitting or dropping to the TFT monitors for protecting their glass parts. Do not use the TFT monitors that have been experienced dropping or strong mechanical shock.
- 4) Do not use or storage the TFT monitors at high temperature and high humidity environment. Particularly, never use or storage the TFT monitors at a location where condensation builds up.
- 5) Avoid using and storing TFT monitors at a location where they are exposed to direct sunlight or ultraviolet rays to prevent the LCD panels from deterioration by ultraviolet rays.
- 6) Do not stain or damage the contacts of the FPC cable .  
FPC cable needs to be inserted until it can reach to the end of connector slot.  
During insertion, make sure to keep the cable in a horizontal position to avoid an oblique insertion.  
Otherwise, it may cause poor contact or deteriorate reliability of the FPC cable.
- 7) The FPC cable is a design very weak to the bend and the pull as it is fixed with the tape.  
Do not bend or pull the FPC cable or carry the TFT monitor by holding the FPC cable.
- 8) Peel off the protective film on the TFT monitors during mounting process.  
Refer to the section 17.5 on how to peel off the protective film.  
We are not responsible for electrostatic discharge failures or other defects occur when peeling off the protective film.
- 9) Please make it to the structure to suppress surroundings of the front polarizer for the display irregularity prevention.

## 17.3 Precautions for Operation

- 1) Since this TFT monitors are not equipped with light shielding for the driver IC, do not expose the driver IC to strong lights during operation as it may cause functional failures.
- 2) In case of powering up or powering off this LCD module, be sure to comply the sequence as instructed in this specification.
- 3) Do not plug in or out the FPC cable while power supply is switch on.  
Plug the FPC cable in and out while power supply is switched off.
- 4) Do not operate the TFT monitors in the strong magnetic field. It may break the TFT monitors.
- 5) Do not display a fixed image on the screen for a long time.  
Use a screen-saver or other measures to avoid a fixed image displayed on the screen for a long time.  
Otherwise, it may cause burn-in image on the screen due the characteristics of liquid crystal.



#### 17.4 Storage Condition for Shipping Cartons

##### Storage environment

- Temperature 0 to 40° C
- Humidity 60%RH or less  
No-condensing occurs under low temperature with high humidity condition.
- Atmosphere No poisonous gas that can erode electronic components and/or wiring materials should be detected.
- Time period 1 year
- Unpacking To prevent damages caused by static electricity, anti-static precautionary measures (e.g. earthing, anti-static mat) should be implemented.  
After unpack, keep product in the appropriate condition, otherwise bubble seal of Protective film may be printed on Polarizer.
- Maximum piling up 7 cartons

##### \*Conditions to storage after unpacking

##### Storage environment

- Temperature 0 to 40° C
- Humidity 60%RH or less  
No-condensing occurs under low temperature with high humidity condition.
- Atmosphere No poisonous gas that can erode electronic components and/or wiring materials should be detected.
- Time period 1 year (Shelf life)
- Others Keep/ store away from direct sunlight  
Storage goods on original tray made by ORTUS.

### 17.5 Precautions for Peeling off the Protective film

The followings work environment and work method are recommended to prevent the TFT monitors from static damage or adhesion of dust when peeling off the protective films.

#### A) Work Environment

- a) Humidity: 50 to 70 %RH, Temperature 15 to 27° C
- b) Operators should wear conductive shoes, conductive clothes, conductive finger tips and grounded wrist-straps.  
Use an electrostatic neutralization blower.  
Anti-static treatment should be implemented to work area's floor.
- c) Use a room shielded against outside dust with sticky floor mat laid at the entrance to eliminate dirt.

#### B) Work Method

- a) Place an ion blower with an optimal distance from the monitor and an optimal wind direction.
- b) Pull the R tape slowly (taking more than 2 seconds to complete) towards the operator to remove the protection film.

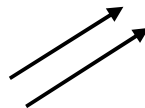

Blower wind direction (Set an ion blower with its adequate conditions.)

### 17.6 Warranty

ORTUS is only liable to defective goods which is stored and used under the condition complying with this specifications and returned within 1 (one) year.

Warranty caused by manufacturing defect shall be conducted by replacement of goods or refundment at unit price.

**APPENDIX**

Reference Method for Measuring Optical Characteristics and Performance

1. Measurement Condition (Backlight ON)

Measuring instruments: CS1000 (KONICA MINOLTA) , LCD7200(OTSUKA ELECTRONICS) ,EZcontrast160D (ELDIM)

Driving condition: Refer to the section "Optical Characteristics"

Measured temperature: 25° C unless specified

Measurement system: See the chart below. The luminance meter is placed on the normal line of measurement system.

Measurement point: At the center of the screen unless otherwise specified

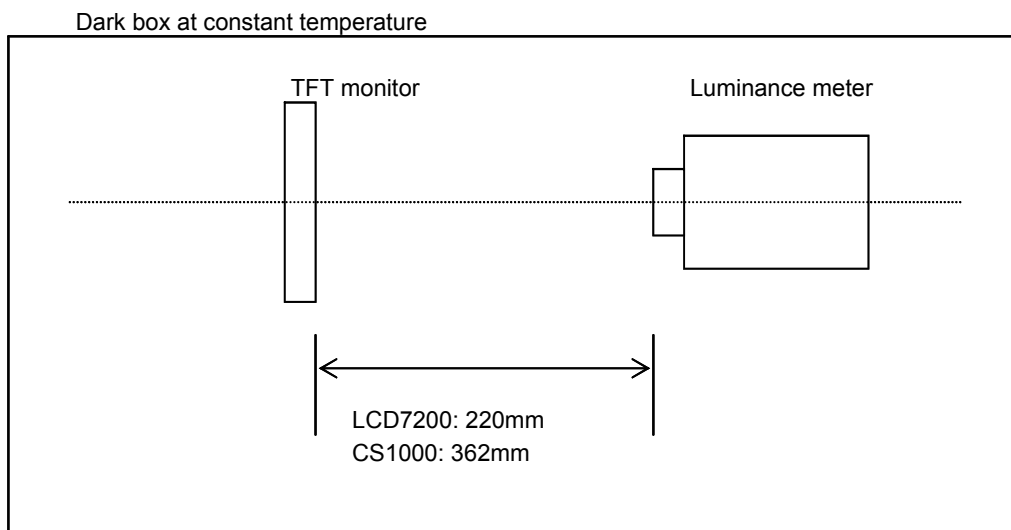

Measurement is made after 30 minutes of lighting of the backlight.

Measurement point: At the center point of the screen  
Brightness distribution: 9 points shown in the following drawing.

<Portrait model>

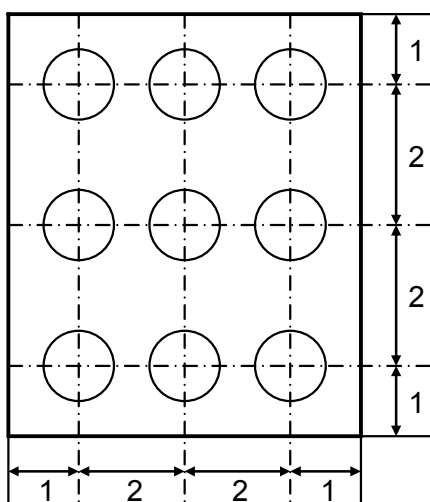

Dimensional ratio of active area

Backlight IL=10.0mA

Measurement Condition (Contrast ratio Backlight OFF only)

Measuring instruments: LCD7200(OTSUKA ELECTRONICS),Ring Light(40,000 lx,φ58)

Driving condition: Refer to the section "Optical Characteristics"

Measured temperature: 25° C unless specified

Measurement system: See the chart below.

Measurement point: At the center of the screen.

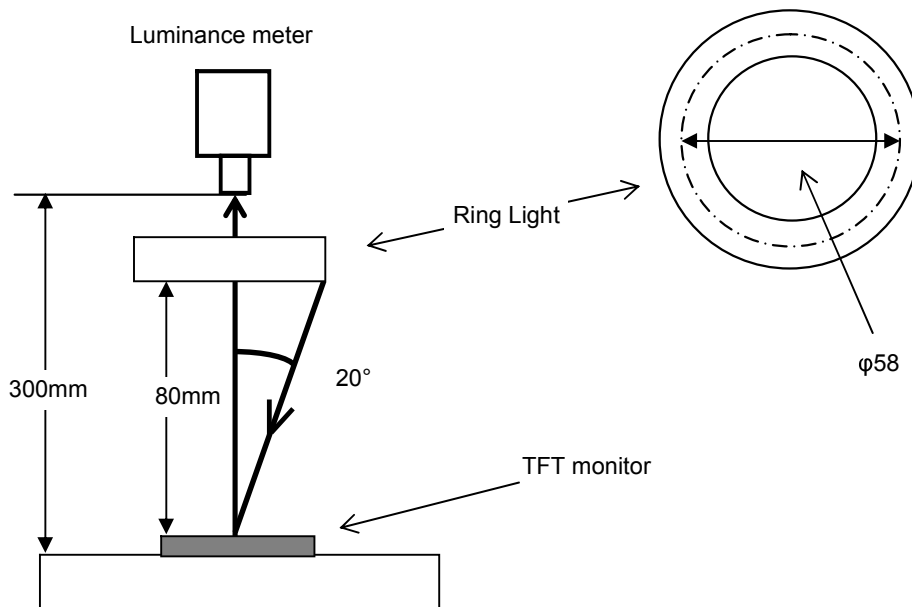

## 2. Test Method

Notice	Item	Test method	Measuring instrument	Remark
1	Response time	<p>Measure output signal waveform by the luminance meter when raster of window pattern is changed from white to black and from black to white.</p> <p style="text-align: center;">Black                      White                      Black</p> <p>White brightness</p> <p>100%</p> <p>90%</p> <p>10%</p> <p>0%</p> <p>Black brightness</p> <p>TON</p> <p>TOFF</p>	LCD7200	<p>Black display [Data]=00h</p> <p>White display [Data]=FFh</p> <p>TON</p> <p>Rise time</p> <p>TOFF</p> <p>Fall time</p>
2	Contrast ratio	<p>Measure maximum luminance Y1([Data]=FFh) and minimum luminance Y2([Data]=00h) at the center of the screen by displaying raster or window pattern. Then calculate the ratio between these two values.</p> <p style="text-align: center;">Contrast ratio = Y1/Y2</p> <p style="text-align: center;">Diameter of measuring point: 8mmφ(CS1000)</p> <p style="text-align: center;">Diameter of measuring point: 3mmφ(LCD7200)</p>	CS1000 LCD7200	Backlight ON Backlight OFF
3	Viewing angle Horizontalθ Verticalφ	Move the luminance meter from right to left and up and down and determine the angles where contrast ratio is 10.	EZcontrast160D	
4	White chromaticity	<p>Measure chromaticity coordinates x and y of CIE1931 colorimetric system at [Data] = FFh</p> <p style="text-align: center;">Color matching function: 2°view</p>	CS1000	
5	Burn-in	Visually check burn-in image on the screen after 2 hours of "window display" (Data=00h/FFh).		At optimized VCOMDC
6	Center brightness	Measure the brightness at the center of the screen.	CS1000	
7	Brightness distribution	<p>(Brightness distribution) = 100 x B/A %</p> <p>A : max. brightness of the 9 points</p> <p>B : min. brightness of the 9 points</p>	CS1000	

