

Baud Rate Generator

Programmable Divider

FEATURES

- On chip crystal oscillator or external frequency input
- Choice of 16 output frequencies
- 16 asynchronous/synchronous baud rates
- Direct UART/USRT/ASTRO/USYNRT compatibility
- High frequency reference output
- TTL, MOS compatibility

PIN CONFIGURATION

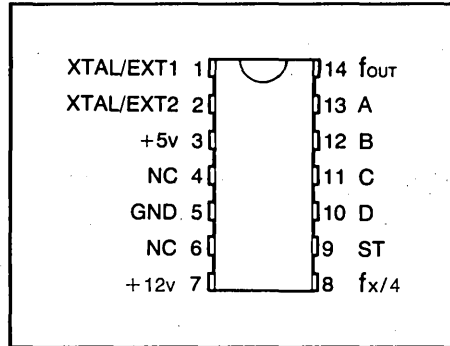

SECTION IV

BLOCK DIAGRAM

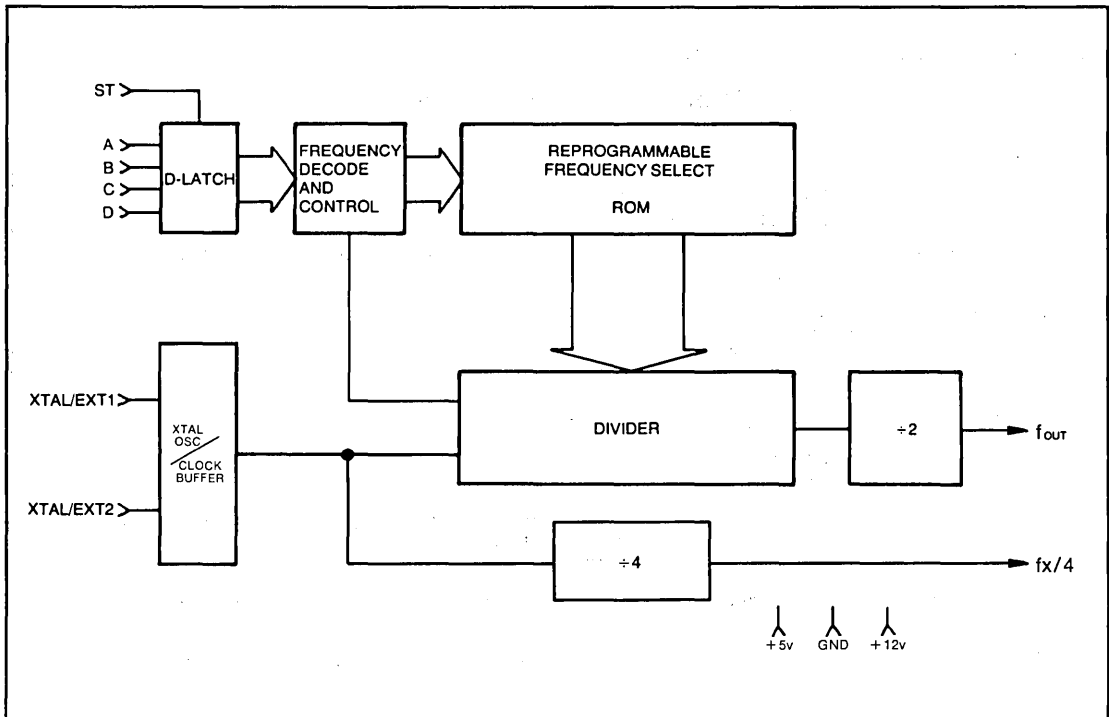

GENERAL DESCRIPTION

The Standard Microsystems COM 5046 Baud Rate Generator/Programmable Divider is an N-channel COPLAMOS® MOS/LSI device which, from a single crystal (on-chip oscillator) or input frequency is capable of generating 16 externally selectable frequencies.

The COM 5046 is specifically dedicated to generating the full spectrum of 16 asynchronous/synchronous data communication frequencies as shown in Table 1. One of the sixteen output frequencies is externally selected by four address inputs; as shown in Table 1.

Internal re-programmable ROM allows the generation of other frequencies from other crystal frequencies or input frequencies. The four address inputs may be strobe (150ns) or DC loaded.

The COM 5046 is basically a programmable 15-stage feedback shift register capable of dividing any modulo up to $(2^{15} - 1)$.

By using the frequency output, it is possible to generate additional divisions of the master clock frequency by cascading COM 5046's. The frequency output is fed into the XTAL/EXT input on a subsequent device. In this way one crystal or input frequency may be used to generate numerous output frequencies.

The COM 5046 can be driven by either an external crystal or TTL logic level inputs; COM 5046T is driven by TTL logic level inputs only.

The COM 5046 provides a high frequency reference output at one-quarter (1/4) the XTAL/EXT input frequency.

Description of Pin Functions

Pin No.	Symbol	Name	Function
1	XTAL/EXT1	Crystal or External Input 1	This input is either one pin of the crystal package or one polarity of the external input.
2	XTAL/EXT2	Crystal or External Input 2	This input is either the other pin of the crystal package or the other polarity of the external input.
3	V _{CC}	Power Supply	+5 volt Supply.
4,6	NC	No Connection	
5	GND	Ground	Ground
7	V _{DD}	Power Supply	+12 volt Supply.
8	f _{X/4}	Reference Frequency	High frequency reference output @ (1/4) f _{IN}
9	ST	Strobe	A high-level strobe loads the Input Address (A _A , A _B , A _C , A _D) into the Input Address register. This input may be strobed or hard wired to a high-level.
10-13	A _D , A _C , A _B , A _A	Input Address	The logic level on these inputs, as shown in Table 1, selects the output frequency.
14	f _{OUT}	Output Frequency	This output runs at a frequency as selected by the Input Address.

For electrical characteristics, see page 175.

ELECTRICAL CHARACTERISTICS COM5016, COM5016T, COM5026, COM5026T, COM5036, COM5036T, COM5046, COM5046T

MAXIMUM GUARANTEED RATINGS*

Operating Temperature Range0°C to + 70°C
Storage Temperature Range-55°C to +150°C
Lead Temperature (soldering, 10 sec.)+325°C
Positive Voltage on any Pin, with respect to ground+18.0V
Negative Voltage on any Pin, with respect to ground-0.3V

*Stresses above those listed may cause permanent damage to the device. This is a stress rating only and functional operation of the device at these or at any other condition above those indicated in the operational sections of this specification is not implied.

ELECTRICAL CHARACTERISTICS (T_A=0°C to 70°C, V_{CC}=+5V±5%, V_{DD}=+12V±5%, unless otherwise noted)

Parameter	Min.	Typ.	Max	Unit	Comments
D.C. CHARACTERISTICS					
INPUT VOLTAGE LEVELS					
Low-level, V _{IL}			0.8	V	excluding XTAL inputs
High-level, V _{IH}	2.0		V _{CC}	V	
OUTPUT VOLTAGE LEVELS					
Low-level, V _{OL}			0.4	V	I _{OL} = 1.6ma
			0.5	V	I _{OL} = 3.2ma
High-level, V _{OH}	V _{CC} -1.5	4.0		V	I _{OH} = 100μA
INPUT CURRENT					
Low-level, I _{IL}			0.3	mA	V _{IN} = GND, excluding XTAL inputs
INPUT CAPACITANCE					
All inputs, C _{IN}		5	10	pf	V _{IN} = GND, excluding XTAL inputs
EXT INPUT LOAD					
		8	10		Series 7400 unit loads
POWER SUPPLY CURRENT					
I _{CC}		28	45	mA	
I _{DD}		12	22	mA	
A.C. CHARACTERISTICS					
CLOCK FREQUENCY		5.0688		MHz	T _A = +25°C XTAL, EXT
PULSE WIDTH					
Clock					50% Duty Cycle ±5%
Strobe	150		DC	ns	See Note 1.
INPUT SET-UP TIME					
Address	50			ns	See Note 1.
INPUT HOLD TIME					
Address	50			ns	
STROBE TO NEW FREQUENCY DELAY			3.5	μS	= 1/f _{IN} (18)

Note 1: Input set-up time can be decreased to ≥ 0ns by increasing the minimum strobe width by 50ns to a total of 200ns.

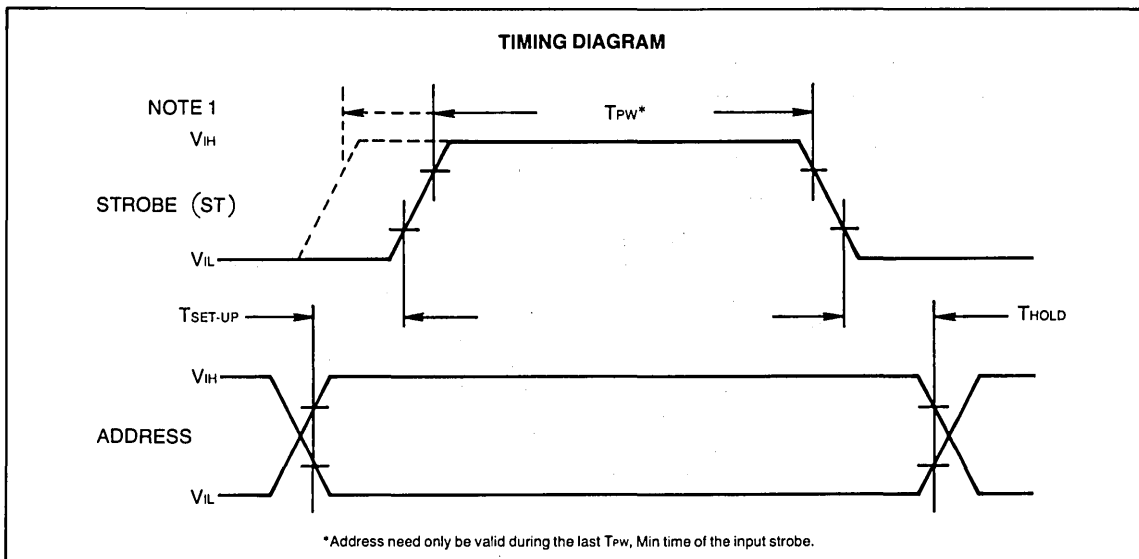

SECTION IV

**Crystal Operation
COM5016
COM5036**

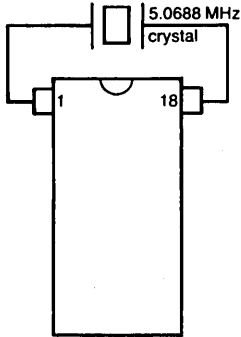

**External Input Operation
COM5016/COM5016T
COM5036/COM5036T**

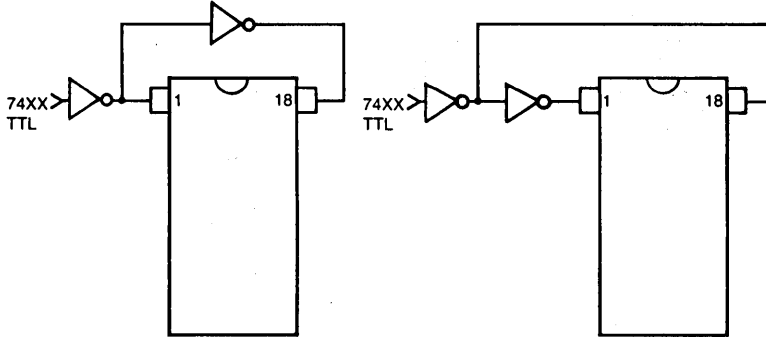

74XX—totem pole or open collector output (external pull-up resistor required)

**Crystal Operation
COM5026
COM5046**

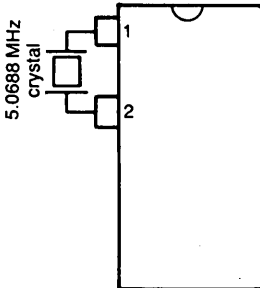

**External Input Operation
COM5026/COM5026T
COM5046/COM5046T**

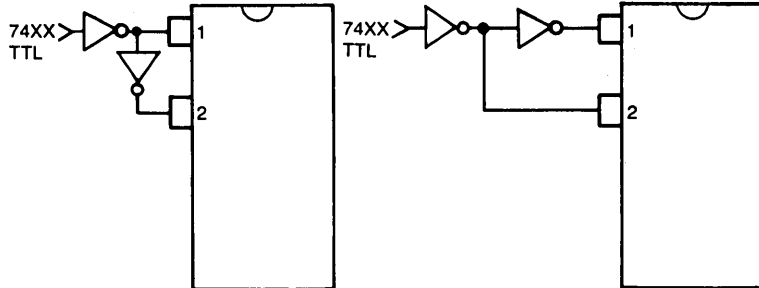

74XX—totem pole or open collector output (external pull-up resistor required)

For ROM re-programming SMC has a computer program available whereby the customer need only supply the input frequency and the desired output frequencies. The ROM programming is automatically generated.

Crystal Specifications

User must specify termination (pin, wire, other)
 Prefer: HC-18/U or HC-25/U
 Frequency — 5.0688 MHz, AT cut
 Temperature range 0°C to 70°C
 Series resistance <50 Ω
 Series Resonant
 Overall tolerance ± .01%
 or as required

Crystal manufacturers (Partial List)

Northern Engineering Laboratories
 357 Beloit Street
 Burlington, Wisconsin 53105
 (414) 763-3591

Bulova Frequency Control Products
 61-20 Woodside Avenue
 Woodside, New York 11377
 (212) 335-6000

CTS Knights Inc.
 101 East Church Street
 Sandwich, Illinois 60548
 (815) 786-8411

Crystek Crystals Corporation
 1000 Crystal Drive
 Fort Myers, Florida 33901
 (813) 936-2109

APPLICATIONS INFORMATION

Charge pump techniques using the +5 volt power supply can be used to generate the +12 volt power supply required. The +12 volt power supply of figure 1 will supply the 22 milli-amps that is typically required.

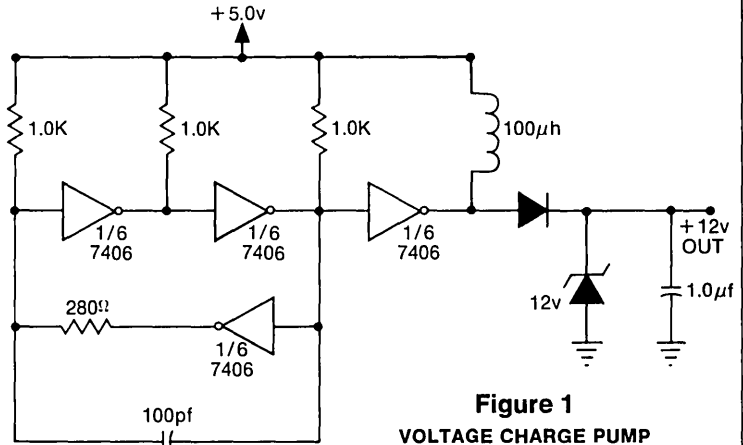

Figure 1
VOLTAGE CHARGE PUMP
SUPPLY FOR +12v SUPPLY

SECTION IV

When powering this device from laboratory or system power supplies, it is important that the Absolute Maximum Ratings not be exceeded or device failure can result. Some power supplies exhibit voltage spikes or "glitches" on their outputs when the AC power is switched on and off. In addition, voltage transients on the AC power line may appear on the DC output. For example, the bench power supply programmed to deliver +12 volts may have large voltage transients when the AC power is switched on and off. If this possibility exists it is suggested that the clamp circuit of figure 2 or a Semtech[®] bi-polarity silicon transient suppressor such as the 1N6110 be used.

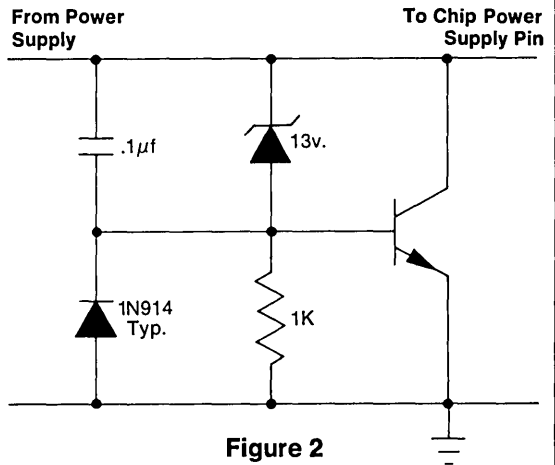

Figure 2
OVER-VOLTAGE
PROTECTION
CIRCUIT

*SEMTECH CORPORATION
652 Mitchell Road
Newbury Park, California 91320
213-629-5392

Baud Rate Generator Output Frequency Options

Table 1. (16X clock)
CRYSTAL FREQUENCY = 5.0688 MHz

Tr'mit/Receive Address				Baud Rate	Theoretical Frequency 16X Clock	Actual Frequency 16X Clock	Percent Error	Duty Cycle %	Divisor
D	C	B	A						
0	0	0	0	50	0.8 KHz	0.8 KHz	—	50/50	6336
0	0	0	1	75	1.2	1.2	—	50/50	4224
0	0	1	0	110	1.76	1.76	—	50/50	2880
0	0	1	1	134.5	2.152	2.1523	0.016	50/50	2355
0	1	0	0	150	2.4	2.4	—	50/50	2112
0	1	0	1	300	4.8	4.8	—	50/50	1056
0	1	1	0	600	9.6	9.6	—	50/50	528
0	1	1	1	1200	19.2	19.2	—	50/50	264
1	0	0	0	1800	28.8	28.8	—	50/50	176
1	0	0	1	2000	32.0	32.081	0.253	50/50	158
1	0	1	0	2400	38.4	38.4	—	50/50	132
1	0	1	1	3600	57.6	57.6	—	50/50	88
1	1	0	0	4800	76.8	76.8	—	50/50	66
1	1	0	1	7200	115.2	115.2	—	50/50	44
1	1	1	0	9600	153.6	153.6	—	48/52	33
1	1	1	1	19,200	307.2	316.8	3.125	50/50	16

Table 2. (16X clock)
CRYSTAL FREQUENCY = 4.9152 MHz

Tr'mit/Receive Address				Baud Rate	Theoretical Frequency 16X Clock	Actual Frequency 16X Clock	Percent Error	Duty Cycle %	Divisor
D	C	B	A						
0	0	0	0	50	0.8 KHz	0.8 KHz	—	50/50	6144
0	0	0	1	75	1.2	1.2	—	50/50	4096
0	0	1	0	110	1.76	1.7589	-0.01	50/50	2793
0	0	1	1	134.5	2.152	2.152	—	50/50	2284
0	1	0	0	150	2.4	2.4	—	50/50	2048
0	1	0	1	300	4.8	4.8	—	50/50	1024
0	1	1	0	600	9.6	9.6	—	50/50	512
0	1	1	1	1200	19.2	19.2	—	50/50	256
1	0	0	0	1800	28.8	28.7438	-0.19	50/50	171
1	0	0	1	2000	32.0	31.9168	-0.26	50/50	154
1	0	1	0	2400	38.4	38.4	—	50/50	128
1	0	1	1	3600	57.6	57.8258	0.39	50/50	85
1	1	0	0	4800	76.8	76.8	—	50/50	64
1	1	0	1	7200	115.2	114.306	-0.77	50/50	43
1	1	1	0	9600	153.6	153.6	—	50/50	32
1	1	1	1	19,200	307.2	307.2	—	50/50	16

Table 3. (32X clock)
CRYSTAL FREQUENCY = 5.0688 MHz

Tr'mit/Receive Address				Baud Rate	Theoretical Frequency 32X Clock	Actual Frequency 32X Clock	Percent Error	Duty Cycle %	Divisor
D	C	B	A						
0	0	0	0	50	1.6 KHz	1.6 KHz	—	50/50	3168
0	0	0	1	75	2.4	2.4	—	50/50	2112
0	0	1	0	110	3.52	3.52	—	50/50	1440
0	0	1	1	134.5	4.304	4.306	.06	50/50	1177
0	1	0	0	150	4.8	4.8	—	50/50	1056
0	1	0	1	200	6.4	6.4	—	50/50	792
0	1	1	0	300	9.6	9.6	—	50/50	528
0	1	1	1	600	19.2	19.2	—	50/50	264
1	0	0	0	1200	38.4	38.4	—	50/50	132
1	0	0	1	1800	57.6	57.6	—	50/50	88
1	0	1	0	2400	76.8	76.8	—	50/50	66
1	0	1	1	3600	115.2	115.2	—	50/50	44
1	1	0	0	4800	153.6	153.6	—	50/50	33
1	1	0	1	7200	230.4	230.4	—	50/50	22
1	1	1	0	9600	307.2	316.8	3.125	50/50	16
1	1	1	1	19,200	614.4	633.6	3.125	50/50	8

OUTPUT FREQUENCY OPTIONS

Part No.	Dash Number		
	Table 1	Table 2	Table 3
5016/5016T	STD	-5	-6
5026/5026T	STD	-5	-6
5036/5036T	STD	N/A	N/A
5046/5046T	STD	N/A	N/A

*When Duty Cycle is not exactly 50%, it is 50% ± 10%.